



Configuring a Basic IS-IS Network

First Published: November 30, 2007

Last Updated: May 5, 2008

This module describes the tasks to configure and monitor a basic Intermediate System-to-Intermediate System (IS-IS) network. The IS-IS process and adjacency formation is also explained. IS-IS is link-state protocol that allows the network designer to organize the network into a group of flooding domains. Often deployed as the Interior Gateway Protocol (IGP) for an ISP network backbone, IS-IS is capable of handling large topologies and large numbers of routing changes.

Finding Feature Information in This Module

Your Cisco IOS software release may not support all of the features documented in this module. For the latest feature information and caveats, see the release notes for your platform and software release. To reach links to specific feature documentation in this module and to see a list of the releases in which each feature is supported, use the “[Feature Information for Configuring a Basic IS-IS Network](#)” section on [page 17](#).

Finding Support Information for Platforms and Cisco IOS and Catalyst OS Software Images

Use Cisco Feature Navigator to find information about platform support and Cisco IOS and Catalyst OS software image support. To access Cisco Feature Navigator, go to <http://www.cisco.com/go/cfn>. An account on Cisco.com is not required.

Contents

- [Prerequisites for Configuring a Basic IS-IS Network, page 2](#)
- [Information About the IS-IS Routing Protocol, page 2](#)
- [How to Create, Monitor, and Make Changes to a Basic IS-IS Network, page 3](#)
- [Configuration Examples for a Basic IS-IS Network, page 12](#)
- [Where to Go Next, page 15](#)
- [Additional References, page 16](#)
- [Feature Information for Configuring a Basic IS-IS Network, page 17](#)



Americas Headquarters:
Cisco Systems, Inc., 170 West Tasman Drive, San Jose, CA 95134-1706 USA

© 2007–2008 Cisco Systems, Inc. All rights reserved.

Prerequisites for Configuring a Basic IS-IS Network

- Before performing the tasks in this module, you should be familiar with the concepts described in the [“Integrated IS-IS Routing Protocol Overview”](#) module.
- You should know your network design and how you want traffic to flow through it before configuring IS-IS. Define areas, prepare an addressing plan for the routers (including defining the NETs), and determine the interfaces that will run Integrated IS-IS. To facilitate verification, a matrix of adjacencies should be prepared before you configure your routers, showing what neighbors should be expected in the adjacencies table. For more information on verifying IS-IS configuration and formed adjacencies, see the [“Monitoring IS-IS”](#) section on page 5.

Information About the IS-IS Routing Protocol

Before you enable IS-IS, you should understand the following concepts:

- [IS-IS Process and Adjacencies, page 2](#)
- [PDU Packet Types in IS-IS Routing, page 3](#)

IS-IS Process and Adjacencies

IS-IS requires some configuration on both the router and the interface. An IS-IS process is created when you enable IS-IS on a router and define a specific tag to identify that routing process. Interfaces configured with a specific tag will be part of the corresponding router process. More than one IS-IS process can run on a router for Connectionless Network Service (CLNS), but only one IS-IS process can run for IP.

Small IS-IS networks are built as a single area that includes all the routers in the network. As the network grows larger, it is usually reorganized into a backbone area made up of the connected set of all Level 2 routers from all areas. The areas are connected to local areas. Within a local area, routers know how to reach all system IDs. Between areas, routers know how to reach the backbone, and the backbone routers know how to reach other areas.

Routers establish Level 1 adjacencies to perform routing within a local area (intra-area routing). Routers establish Level 2 adjacencies to perform routing between Level 1 areas (inter-area routing).

If the network administrator does not specify Level 1 or Level 2 routing for the routing process being configured, the default routing behavior for the routing process will be Level 1-2.

If Level 2 routing is configured on any process, additional processes are automatically configured as Level 1, with the exception of previously configured Level 2 process, which will remain Level 2. You can have only one Level-2 process. You can configure the Level-2 process to perform Level-1 routing at the same time. If Level-2 routing is not desired for a router instance, use the **is-type** command in router configuration mode to remove the Level-2 capability. You can also use the **is-type** command to configure a different router instance as a Level-2 router.

Some networks use legacy equipment that supports only Level 1 routing. These devices are typically organized into many small areas that cannot be aggregated due to performance limitations. Cisco routers are used to interconnect each area to the Level 2 backbone.

Network entity titles (NETs) define the area addresses and the system ID of the router. See the [“Configuring ISO CLNS”](#) chapter in the *Cisco IOS ISO CLNS Configuration Guide* for a more detailed discussion of NETs.

PDU Packet Types in IS-IS Routing

The OSI stack defines a unit of data as a protocol data unit (PDU). A frame therefore is regarded by OSI as a data-link PDU, and a packet is regarded as a network PDU. There are four types of PDU packets, and each type can be Level 1 or Level 2:

- LSP—Link-state PDU. Used to distribute link-state information.
- IIH PDU—For IS-IS this is called the IS-IS Hello PDU. Used to establish and maintain adjacencies.



Note On point-to-point links, IIH PDUs will be the same for Level 1 and Level 2. Both Level-1 and Level-2 IIH use the same type of PDU, but they carry different circuit types.

- PSNP—partial sequence numbers protocol data unit (PDU). Used to acknowledge and request link-state information.
- CSNP—complete sequence number protocol data unit (PDU). Used to distribute the complete link-state database of a router.

IS-IS LSPs include specific information about the router's attachments. The following information is included in multiple TLV fields in the main body of the LSP:

- The links to neighbor router intermediate systems (ISs), including the metrics of those interfaces
- The links to the neighbor end systems (ESs)

How to Create, Monitor, and Make Changes to a Basic IS-IS Network

To create a basic IS-IS network, verify and monitor configuration, and make changes to the network, perform the tasks in the following sections:

- [Enabling IS-IS as an IP Routing Protocol on the Router, page 3](#) (required)
- [Enabling IS-IS as an IP Routing Protocol on the Interface, page 4](#) (required)
- [Monitoring IS-IS, page 5](#) (optional)
- [Shutting Down IS-IS to Make Changes to Your IS-IS Network, page 10](#) (optional)

Enabling IS-IS as an IP Routing Protocol on the Router

Perform this task to enable IS-IS on the router. You need give identify the router within the IS-IS network by assigning a NET to the router and specifying the area address and system ID for the IS-IS routing process.

SUMMARY STEPS

1. **enable**
2. **configure terminal**
3. **router isis** [*area-tag*]

4. **net** *network-entity-title*
5. **end**

DETAILED STEPS

	Command or Action	Purpose
Step 1	enable Example: Router> enable	Enables privileged EXEC mode. <ul style="list-style-type: none"> • Enter your password if prompted.
Step 2	configure terminal Example: Router# configure terminal	Enters global configuration mode.
Step 3	router isis [<i>area-tag</i>] Example: Router(config)# router isis	Assigns a tag to an IS-IS process. Enters router configuration mode. <ul style="list-style-type: none"> • Configure tags to identify multiple IS-IS processes by giving a meaningful name for each routing process. If the tag is not specified, a null tag (0) is assumed and the process is referenced with a null tag. The tag name must be unique among all IP router processes for the router.
Step 4	net <i>network-entity-title</i> Example: Router(config-router)# net 49.0001.0000.0000.000b.00	Configures the NET on the router. <ul style="list-style-type: none"> • The NET identifies the router for IS-IS.
Step 5	end Example: Router(config-router)# end	Exits router configuration mode and returns to privileged EXEC mode.

Enabling IS-IS as an IP Routing Protocol on the Interface

Perform this task to enable IS-IS on the interfaces on the routers, including the interfaces to stub networks, such as loopback interfaces. Interfaces that are to use IS-IS to distribute their IP information (and additionally that might be used to establish IS-IS adjacencies) must be configured with the **ip router isis** command, and the *area-tag* argument can be used to specify to which IS-IS process the router belongs.

SUMMARY STEPS

1. **enable**
2. **configure terminal**
3. **interface** *type number*
4. **ip address** *ip-address mask* [**secondary**]

5. **ip router isis** *[area-tag]*
6. **end**

DETAILED STEPS

	Command or Action	Purpose
Step 1	enable Example: Router> enable	Enables privileged EXEC mode. <ul style="list-style-type: none">• Enter your password if prompted.
Step 2	configure terminal Example: Router# configure terminal	Enters global configuration mode.
Step 3	interface <i>type number</i> Example: Router(config)# interface ethernet 4/0	Enters interface configuration mode.
Step 4	ip address <i>ip-address mask [secondary]</i> Example: Router(config-if)# ip address 172.16.1.27 255.255.255.0	Sets the primary IP address on the interface.
Step 5	ip router isis <i>[area-tag]</i> Example: Router(config-if)# ip router isis company1	Enables IS-IS on the interfaces that are to use IS-IS to distribute their IP information (and additionally that might be used to establish IS-IS adjacencies). Note If there is more than one IS-IS process on the router, repeat the ip router isis command for each interface, specifying an area tag for each interface to associate each interface with the specific process to which it belongs.
Step 6	end Example: Router(config-if)# end	Exits interface configuration mode and returns to privileged EXEC mode.

Monitoring IS-IS

This task explains how to display information to verify the configuration and operation of IS-IS. It is highly recommended to record the output for these commands once the IS-IS network has been set up and compare to later output in order to verify network stability and to gain information useful for troubleshooting purposes.

Enter one or more of the following commands to monitor IS-IS on your network. You do not need to enter the **show** commands in any specific order.

SUMMARY STEPS

1. **enable**
2. **configure terminal**
3. **isis display delimiter** [return *count* | character *count*]
4. **exit**
5. **show ip protocols**
6. **show clns is** *area-tag* **neighbors** [*type number*] [**detail**]
7. **show clns interface** [*type number*]
8. **show clns is** *area-tag* **neighbors** [*type number*] [**detail**]
9. **show clns** *area-tag* **traffic**
10. **show ip route** [*ip-address* [*mask*]] [[**longer-prefixes**] | *protocol* [*process-id*] | **list** [*access-list-number* | *access-list-name*] | **static download**]]
11. **show isis** [*process-tag*] **database** [**level-1**] [**level-2**] [**l1**] [**l2**] [**detail**] [**lspid**]
12. **show isis database verbose**
13. **show isis lsp-log**
14. **show isis** [*area-tag*] [**ipv6** | *] **spf-log**
15. **show isis** [*process-tag*] [**ipv6** | *] **topology**
16. **show isis** *area-tag* **neighbors** [**detail**]

DETAILED STEPS

	Command or Action	Purpose
Step 1	enable Example: Router> enable	Enables privileged EXEC mode. <ul style="list-style-type: none"> • Enter your password if prompted.
Step 2	configure terminal Example: Router# configure terminal	Enters global configuration mode.
Step 3	isis display delimiter [return <i>count</i> character <i>count</i>] Example: Router(config)# isis display delimiter return 15	Makes output from multiarea displays easier to read by specifying the delimiter to use to separate displays of information.
Step 4	exit Example: Router(config)# exit	Returns to privileged EXEC mode.

	Command or Action	Purpose
Step 5	<p>show ip protocols</p> <p>Example: Router# show ip protocols</p>	<p>Displays the parameters and current state of the active routing protocol process.</p> <ul style="list-style-type: none"> You can use this command to learn what protocols are active, what interfaces they are active on, what networks they are routing for, and other parameters that relate to the routing protocols.
Step 6	<p>show clns is area-tag neighbors [type number] [detail]</p> <p>Example: Router# show clns is tag3 neighbors detail</p>	<p>Displays IS-IS information for IS-IS router adjacencies.</p>
Step 7	<p>show clns interface [type number]</p> <p>Example: Router# show clns interface</p>	<p>List the CLNS-specific information about each interface.</p>
Step 8	<p>show clns area-tag neighbors [type number] [area] [detail]</p> <p>Example: Router# show clns area3 neighbors</p>	<p>Displays both ES and IS neighbors.</p> <ul style="list-style-type: none"> The show clns neighbor command output verifies that the right adjacencies have established. A matrix of adjacencies should be prepared before you configure your routers, showing what neighbors should be expected in the adjacencies table, to facilitate verification.

Command or Action	Purpose
<p>Step 9 <code>show clns area-tag traffic</code></p> <p>Example: Router# show clns area3 traffic</p>	<p>Displays traffic statistics.</p> <p>To monitor IS-IS for stability once it has been deployed across your network, enter the show clns traffic command to check the following important statistics: high numbers of SPF's, checksum errors, and retransmissions. To troubleshoot IS-IS behavior, you can use the output from the show clns traffic command to check for the following indicators:</p> <ul style="list-style-type: none"> • The number of link-state PDUs (LSPs) can help you determine the stability of the IS-IS network. The number of LSPs should never be zero. However, an LSP count that keeps increasing over a short time period indicates a network issue. • LSP retransmissions should stay low. A later execution of the show clns traffic command that shows an increase in LSP retransmissions, as compared to an earlier execution of the command, can indicate instability or traffic problems. • To check for partial route calculations (PRCs), enter the show clns traffic command. PRCs are flooded when a change that does not affect topology is reported through an LSP; typical examples include the addition or removal of a prefix or metric changes for external or passive interfaces. A PRC update queue that remains full or increases to the maximum value for long periods of time indicates network instability. • LSP checksum errors indicate a problem. • The update queue should not stay full and should not drop much.
<p>Step 10 <code>show ip route [ip-address [mask]] [[longer-prefixes] protocol [process-id] list [access-list-number access-list-name] static download]</code></p> <p>Example: Router# show ip route 172.16.0.21</p>	<p>Displays the current state of the routing table.</p>
<p>Step 11 <code>show isis [process-tag] database [level-1] [level-2] [l1] [l2] [detail] [lspid]</code></p> <p>Example: Router# show isis database detail</p>	<p>Displays additional information about the IS-IS database.</p> <ul style="list-style-type: none"> • Displays the link-state database for Level-1 and Level-2, the contents for each LSP, and the link-state protocol PDU identifier.
<p>Step 12 <code>show isis database verbose</code></p> <p>Example: Router# show isis database verbose</p>	<p>Displays additional information about the IS-IS database such as the sequence number, checksum, and holdtime for LSPs.</p>

	Command or Action	Purpose
Step 13	<code>show isis lsp-log</code> Example: Router# show isis lsp-log	Displays a log of LSPs including time of occurrence, count, interface, and the event that triggered the LSP.
Step 14	<code>show isis [area-tag] [ipv6 *] spf-log</code> Example: Router# show isis spf-log	Displays how often and why the router has run a full shortest path first (SPF) calculation. <ul style="list-style-type: none"> If the router continues to run SPF without ceasing, there might be an issue regarding a change in the network (intra-area). The cause for the continued SPF calculations could be an interconnecting link that is transitioning up/down/up/down or a metric change. It is normal for the SPF calculation to run a few times when a network change occurs, but then it should cease.
Step 15	<code>show isis [process-tag] [ipv6 *] topology</code> Example: Router# show isis topology	Displays a list of all connected routers in all areas.
Step 16	<code>show isis [area-tag] neighbors [detail]</code> Example: Router# show isis neighbors detail	Displays IS-IS adjacency information. <ul style="list-style-type: none"> The <code>show isis neighbor detail</code> command output verifies that the right adjacencies have established. A matrix of adjacencies should be prepared before you configure your routers, showing what neighbors should be expected in the adjacencies table, to facilitate verification.

Example

When the `show isis neighbors` command is entered with the `detail` keyword, the output provides information on the IS-IS adjacencies that have formed.

```
Router1# show isis neighbors detail
```

```
System Id      Type Interface IP Address      State Holdtime Circuit Id
Router2        L2  Et1/0      10.1.1.0        UP    255      Circuit3.01
  Area Address(es): 32
  SNPA: aabb.cc00.2001
  State Changed: 00:00:14
  LAN Priority: 64
  Format: Phase V
```

Troubleshooting Tips

You can use the following two system debugging commands to check your IS-IS IPv4 implementation.

- If adjacencies are not coming up properly, use the `debug isis adj-packets` command.
- To display a log of significant events during an IS-IS SPF calculation, use the `debug isis spf-events` command.

Shutting Down IS-IS to Make Changes to Your IS-IS Network

You can shut down IS-IS (placing it in an administrative down state) to make changes to the IS-IS protocol configuration, without losing your configuration parameters. You can shut down IS-IS at the interface level or at the global IS-IS process level. If the router was rebooted when the protocol was turned off, the protocol would be expected to come back up in the disabled state. When the protocol is set to the administrative down state, network administrators are allowed to administratively turn off the operation of the IS-IS protocol without losing the protocol configuration, to make a series of changes to the protocol configuration without having the operation of the protocol transition through intermediate—and perhaps undesirable—states, and to then reenable the protocol at a suitable time.

Before the introduction of the Integrated IS-IS Protocol Shutdown Support Maintaining Configuration Parameters feature, there was no nondestructive way to disable IS-IS operation. The only way to disable IS-IS at the router level was to issue the **no router isis** command, which removes the IS-IS configuration. At the interface level there are two ways to disable IS-IS operation. You can enter the **no ip router isis** command to remove IS-IS from the specified interface, or you can put the interface into passive mode such that the IP address of the specified interface will still be advertised. In either case, the current IS-IS configuration will be removed.

This section contains the following procedures:

- [Shutting Down IS-IS in Interface Mode, page 10](#) (optional)
- [Shutting Down IS-IS in Router Mode, page 11](#) (optional)

Shutting Down IS-IS in Interface Mode

This task describes how to disable the IS-IS protocol in interface configuration mode so that it will not form adjacencies using the specified interface. The IP address of the specified interface will be placed into the LSP that is generated by the router.

SUMMARY STEPS

1. **enable**
2. **configure terminal**
3. **interface** *type number*
4. **isis protocol shutdown**
5. **end**

DETAILED STEPS

	Command or Action	Purpose
Step 1	enable Example: Router> enable	Enables privileged EXEC mode. <ul style="list-style-type: none"> • Enter your password if prompted.
Step 2	configure terminal Example: Router# configure terminal	Enters global configuration mode.

	Command or Action	Purpose
Step 3	<code>interface type number</code> Example: Router(config)# interface Ethernet 0	Configures an interface and enters interface configuration mode.
Step 4	<code>isis protocol shutdown</code> Example: Router(config-if)# isis protocol shutdown	Disables the IS-IS protocol so that it cannot form adjacencies on a specified interface and places the IP address of the interface into the LSP that is generated by the router.
Step 5	<code>end</code> Example: Router(config-if)# end	Exits interface configuration mode and returns to privileged EXEC mode.

Shutting Down IS-IS in Router Mode

This task describes how to disable the IS-IS protocol in router configuration mode so that no adjacencies are formed on any interface and so that the IS-IS LSP database is cleared while IS-IS still runs on the router.

SUMMARY STEPS

1. `enable`
2. `configure terminal`
3. `router isis area-tag`
4. `protocol shutdown`
5. `end`

DETAILED STEPS

	Command or Action	Purpose
Step 1	<code>enable</code> Example: Router> enable	Enables privileged EXEC mode. <ul style="list-style-type: none"> • Enter your password if prompted.
Step 2	<code>configure terminal</code> Example: Router# configure terminal	Enters global configuration mode.
Step 3	<code>router isis area-tag</code> Example: Router(config)# router isis 1	Enables the IS-IS routing protocol and specifies an IS-IS process. <ul style="list-style-type: none"> • Enters router configuration mode.

	Command or Action	Purpose
Step 4	<code>protocol shutdown</code> Example: Router(config-router)# <code>protocol shutdown</code>	Prevents IS-IS from forming any adjacency on any interface and clears the IS-IS LSP database, without actually removing the IS-IS configuration.
Step 5	<code>end</code> Example: Router(config-router)# <code>end</code>	Exits router configuration mode and returns to privileged EXEC mode.

Configuration Examples for a Basic IS-IS Network

This section provides the following configuration examples:

- [Configuring a Basic IS-IS Network: Example, page 12](#)
- [Shutting Down IS-IS in Interface Mode: Example, page 14](#)
- [Shutting Down IS-IS in Router Mode: Example, page 15](#)

Configuring a Basic IS-IS Network: Example

The following example shows how to configure three routers to run IS-IS as an IP routing protocol. [Figure 1](#) illustrates the sample configuration.

Router A Configuration

```
router isis
 net 49.0001.0000.0000.000a.00
 interface ethernet0/0
  ip address 10.1.1.1 255.255.255.0
  ip router isis
 interface serial 2/0
  ip router isis
  ip address 192.168.1.2 255.255.255.0
```

Router B Configuration

```
router isis
 net 49.0001.0000.0000.000b.00
 interface ethernet0/0
  ip router isis
  ip address 172.17.1.1 255.255.255.0
 interface serial2/0
  ip router isis
  ip address 192.168.1.1 255.255.255.0
 interface serial5/0
  ip router isis
  ip address 172.21.1.1 255.255.255.0
```

Router C Configuration

```
router isis
 net 49.0001.0000.0000.000c.00
 interface ethernet2/0
  ip router isis
```

```

ip address 172.21.1.2 255.255.255.0
interface serial5/0
ip router isis
ip address 172.22.1.1 255.255.255.0

```

The **show isis topology** command displays the following information about how the routers are connected within the IS-IS network:

```
RouterB# show isis topology
```

IS-IS paths to level-1 routers

System Id	Metric	Next-Hop	Interface	SNPA
RouterA	10	RouterA	Se2/0	*HDLC*
RouterB	--			
RouterC	10	RouterC	Se5/0	*HDLC*

IS-IS paths to level-2 routers

System Id	Metric	Next-Hop	Interface	SNPA
RouterA	10	RouterA	Se2/0	*HDLC*
RouterB	--			
RouterC	10	RouterC	Se5/0	*HDLC*

The **show isis database** command displays following information for the Level 1 and Level 2 LSPs for each router in the IS-IS network.

```
RouterB# show isis database
```

IS-IS Level-1 Link State Database:

LSPID	LSP Seq Num	LSP Checksum	LSP Holdtime	ATT/P/OL
RouterA.00-00	0x00000005	0x1A1D	1063	0/0/0
RouterB.00-00	* 0x00000006	0xD15B	1118	0/0/0
RouterC.00-00	0x00000004	0x3196	1133	1/0/0

IS-IS Level-2 Link State Database:

LSPID	LSP Seq Num	LSP Checksum	LSP Holdtime	ATT/P/OL
RouterA.00-00	0x00000008	0x0BF4	1136	0/0/0
RouterB.00-00	* 0x00000008	0x1701	1137	0/0/0
RouterC.00-00	0x00000004	0x3624	1133	0/0/0

The **show ip route** command displays information about the interfaces of each router, including their IP addresses and how they are connected to Router B:

```
RouterB# show ip route
```

Codes: C - connected, S - static, R - RIP, M - mobile, B - BGP

D - EIGRP, EX - EIGRP external, O - OSPF, IA - OSPF inter area

N1 - OSPF NSSA external type 1, N2 - OSPF NSSA external type 2

E1 - OSPF external type 1, E2 - OSPF external type 2

i - IS-IS, su - IS-IS summary, L1 - IS-IS level-1, L2 - IS-IS level-2

ia - IS-IS inter area, * - candidate default, U - per-user static route

o - ODR, P - periodic downloaded static route

Gateway of last resort is not set

```

172.17.0.0/24 is subnetted, 1 subnets
C    172.17.1.0 is directly connected, Ethernet0/0
172.16.0.0/24 is subnetted, 1 subnets
C    172.16.1.0 is directly connected, Serial4/0
172.21.0.0/24 is subnetted, 1 subnets
C    172.21.1.0 is directly connected, Serial5/0
172.22.0.0/24 is subnetted, 1 subnets
i L1 172.22.1.0 [115/20] via 172.21.1.2, Serial5/0
10.0.0.0/24 is subnetted, 1 subnets
i L1 10.1.1.0 [115/20] via 192.168.1.2, Serial2/0

```

```
C 192.168.1.0/24 is directly connected, Serial2/0
C 192.168.3.0/24 is directly connected, Serial3/0
```

The **show isis spf-log** command displays logs of Level 1 and Level 2 LSPs including time of occurrence, duration, count, and the event that triggered the LSP.

```
RouterB## show isis spf-log

level 1 SPF log
When   Duration  Nodes  Count  First trigger LSP  Triggers
00:01:30    0      3      7      RouterB.00-00     PERIODIC NEWADJ NEWLSP TLVT

level 2 SPF log
When   Duration  Nodes  Count  First trigger LSP  Triggers
00:01:31    0      3      7      RouterB.00-00     PERIODIC NEWADJ NEWLSP TLVT
```

Figure 1 IS-IS Routing

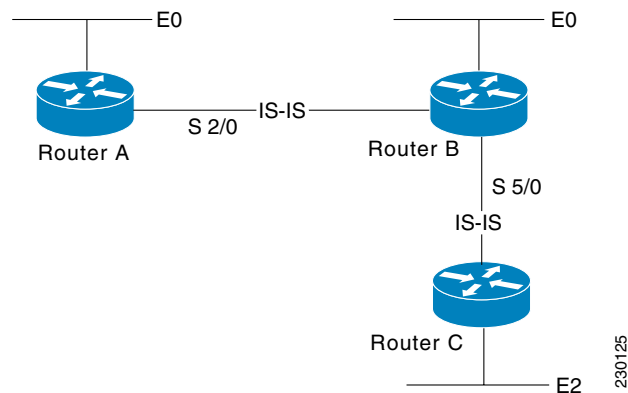

Shutting Down IS-IS in Interface Mode: Example

The following router output shows that the router has two IS-IS adjacencies:

```
Router# show clns neighbors

System Id  Interface  SNPA                State  Holdtime  Type      Protocol
first     Et3/1     0002.7dd6.1c21     Up     25        L1L2     IS-IS
second    Et3/2     0004.6d25.c056     Up     29        L1L2     IS-IS
```

When the **isis protocol shutdown** command is entered for Ethernet interface 3/1, the IS-IS protocol will be disabled for the specified interface:

```
Router# configure terminal
Enter configuration commands, one per line. End with CNTL/Z.
Router(config)# interface ethernet3/1
Router(config-if)# isis protocol shutdown
Router(config-if)# end
```

The following router output shows that the adjacency for Ethernet interface 3/1 has not formed:

```
Router# show clns neighbors

System Id  Interface  SNPA                State  Holdtime  Type      Protocol
second     Et3/2     0004.6d25.c056     Up     27        L1L2     IS-IS
```

Shutting Down IS-IS in Router Mode: Example

The following router output shows that the router has two IS-IS adjacencies:

```
Router# show clns neighbors
```

System Id	Interface	SNPA	State	Holdtime	Type	Protocol
south	Et3/1	0002.7dd6.1c21	Up	29	L1L2	IS-IS
north	Et3/2	0004.6d25.c056	Up	28	L1L2	IS-IS

The **protocol shutdown** command is entered so that IS-IS is disabled and no adjacencies will be formed on any interface:

```
Router# configure terminal
Enter configuration commands, one per line. End with CNTL/Z.
Router(config)# router isis areal
Router(config-router)# protocol shutdown
Router(config-router)# end
```

The following router output now shows that both adjacencies are gone.

```
Router# show clns neighbors
```

System Id	Interface	SNPA	State	Holdtime	Type	Protocol
-----------	-----------	------	-------	----------	------	----------

When the **no protocol shutdown** command is entered, the adjacencies will again be formed on both interfaces:

```
Router(config)# router isis areal
Router(config-router)# no protocol shutdown
Router(config-router)# end
Router# show clns neighbors
```

System Id	Interface	SNPA	State	Holdtime	Type	Protocol
south	Et3/1	0002.7dd6.1c21	Up	24	L1L2	IS-IS
north	Et3/2	0004.6d25.c056	Up	24	L1L2	IS-IS

Where to Go Next

- To customize IS-IS for your network design, see the “[Customizing IS-IS for Your Network Design](#)” module.
- To customize IS-IS for achieving fast convergence and scalability, see the following modules:
 - “[Overview of IS-IS Fast Convergence](#)”
 - “[Setting Best Practice Parameters for IS-IS Fast Convergence](#)”
 - “[Reducing Failure Detection Times in IS-IS Networks](#)”
 - “[Reducing Link Failure and Topology Change Notification Times in IS-IS Networks](#)”
 - “[Reducing Alternate-Path Calculation Times in IS-IS Networks](#)”
- To enhance IS-IS network security, see the “[Enhancing Security in an IS-IS Network](#)” module.

Additional References

The following sections provide references related to configuring basic IS-IS.

Related Documents

Related Topic	Document Title
IS-IS commands: complete command syntax, command mode, defaults, command history, usage guidelines, and examples	Cisco IOS IP Routing Protocols Command Reference
Roadmap of IS-IS features	“Integrated IS-IS Features Roadmap” module
Overview of IS-IS concepts	“Integrated IS-IS Routing Protocol Overview” module
Customizing IS-IS for achieving fast convergence and scalability	“Overview of IS-IS Fast Convergence” module

Standards

Standard	Title
No new or modified standards are supported, and support for existing standards has not been modified.	—

MIBs

MIB	MIBs Link
<ul style="list-style-type: none"> CISCO-IETF-IP-FORWARD-MIB CISCO-IETF-IP-MIB 	To locate and download MIBs for selected platforms, Cisco IOS releases, and feature sets, use Cisco MIB Locator found at the following URL: http://www.cisco.com/go/mibs

RFCs

RFC	Title
RFC 1195	Use of OSI IS-IS for Routing in TCP/IP and Dual Environments

Technical Assistance

Description	Link
<p>The Cisco Support website provides extensive online resources, including documentation and tools for troubleshooting and resolving technical issues with Cisco products and technologies.</p> <p>To receive security and technical information about your products, you can subscribe to various services, such as the Product Alert Tool (accessed from Field Notices), the Cisco Technical Services Newsletter, and Really Simple Syndication (RSS) Feeds.</p> <p>Access to most tools on the Cisco Support website requires a Cisco.com user ID and password.</p>	<p>http://www.cisco.com/techsupport</p>

Feature Information for Configuring a Basic IS-IS Network

Table 1 lists the features in this module and provides links to specific configuration information. Only features that were introduced or modified in Cisco IOS Release 12.2(1), 12.0(3)S, or a later release appear in the table.

For information on a feature in this technology that is not documented here, see the “[Integrated IS-IS Features Roadmap](#)” module.

Not all commands may be available in your Cisco IOS software release. For release information about a specific command, see the command reference documentation.

Use Cisco Feature Navigator to find information about platform support and software image support. Cisco Feature Navigator enables you to determine which Cisco IOS and Catalyst OS software images support a specific software release, feature set, or platform. To access Cisco Feature Navigator, go to <http://www.cisco.com/go/cfn>. An account on Cisco.com is not required.



Note

Table 1 lists only the Cisco IOS software release that introduced support for a given feature in a given Cisco IOS software release train. Unless noted otherwise, subsequent releases of that Cisco IOS software release train also support that feature.

Table 1 Feature Information for Configuring a Basic IS-IS Network

Feature Name	Releases	Feature Information
Integrated IS-IS Protocol Shutdown Support Maintaining Configuration Parameters	12.0(27)S 12.2(25)S 12.3(4)T	<p>The Integrated IS-IS Protocol Shutdown Support Maintaining Configuration Parameters feature allows you to disable the Integrated Intermediate System-to-Intermediate System (IS-IS) protocol at the interface level or at the global IS-IS process level without removing the IS-IS configuration parameters.</p> <p>The following section provides information about this feature:</p> <ul style="list-style-type: none"> Shutting Down IS-IS to Make Changes to Your IS-IS Network, page 10

CCDE, CCSI, CCENT, Cisco Eos, Cisco HealthPresence, the Cisco logo, Cisco Lumin, Cisco Nexus, Cisco Nurse Connect, Cisco Stackpower, Cisco StadiumVision, Cisco TelePresence, Cisco WebEx, DCE, and Welcome to the Human Network are trademarks; Changing the Way We Work, Live, Play, and Learn and Cisco Store are service marks; and Access Registrar, Aironet, AsyncOS, Bringing the Meeting To You, Catalyst, CCDA, CCDP, CCIE, CCIP, CCNA, CCNP, CCSP, CCVP, Cisco, the Cisco Certified Internetwork Expert logo, Cisco IOS, Cisco Press, Cisco Systems, Cisco Systems Capital, the Cisco Systems logo, Cisco Unity, Collaboration Without Limitation, EtherFast, EtherSwitch, Event Center, Fast Step, Follow Me Browsing, FormShare, GigaDrive, HomeLink, Internet Quotient, IOS, iPhone, iQuick Study, IronPort, the IronPort logo, LightStream, Linksys, MediaTone, MeetingPlace, MeetingPlace Chime Sound, MGX, Networkers, Networking Academy, Network Registrar, PCNow, PIX, PowerPanels, ProConnect, ScriptShare, SenderBase, SMARTnet, Spectrum Expert, StackWise, The Fastest Way to Increase Your Internet Quotient, TransPath, WebEx, and the WebEx logo are registered trademarks of Cisco Systems, Inc. and/or its affiliates in the United States and certain other countries.

All other trademarks mentioned in this document or website are the property of their respective owners. The use of the word partner does not imply a partnership relationship between Cisco and any other company. (0903R)

Any Internet Protocol (IP) addresses used in this document are not intended to be actual addresses. Any examples, command display output, and figures included in the document are shown for illustrative purposes only. Any use of actual IP addresses in illustrative content is unintentional and coincidental.

© 2007–2008 Cisco Systems, Inc. All rights reserved.