



Cisco BGP Overview

First Published: May 2, 2005
Last Updated: May 5, 2009

Border Gateway Protocol (BGP) is an interdomain routing protocol designed to provide loop-free routing between separate routing domains that contain independent routing policies (autonomous systems). The Cisco IOS software implementation of BGP version 4 includes support for 4-byte autonomous system numbers and multiprotocol extensions to allow BGP to carry routing information for IP multicast routes and multiple Layer 3 protocol address families including IP Version 4 (IPv4), IP Version 6 (IPv6), Virtual Private Networks version 4 (VPNv4), Connectionless Network Services (CLNS), and Layer 2 VPN (L2VPN). This module contains conceptual material to help you understand how BGP is implemented in Cisco IOS software.

Finding Feature Information

Your software release may not support all the features documented in this module. For the latest feature information and caveats, see the release notes for your platform and software release. To find information about the features documented in this module, and to see a list of the releases in which each feature is supported, see the [“Feature Information for Cisco BGP Overview”](#) section on page 18.

Use Cisco Feature Navigator to find information about platform support and Cisco IOS and Catalyst OS software image support. To access Cisco Feature Navigator, go to <http://www.cisco.com/go/cfn>. An account on Cisco.com is not required.

Contents

- [Prerequisites for Cisco BGP, page 2](#)
- [Restrictions for Cisco BGP, page 2](#)
- [Information About Cisco BGP, page 2](#)
- [Where to Go Next, page 15](#)



Americas Headquarters:
Cisco Systems, Inc., 170 West Tasman Drive, San Jose, CA 95134-1706 USA

- [Additional References, page 16](#)
- [Feature Information for Cisco BGP Overview, page 18](#)

Prerequisites for Cisco BGP

This document assumes knowledge of CLNS, IPv4, IPv6, multicast, VPNv4, and Interior Gateway Protocols (IGPs). The amount of knowledge required for each technology is dependent on your deployment.

Restrictions for Cisco BGP

A router that runs Cisco IOS software can be configured to run only one BGP routing process and to be a member of only one BGP autonomous system. However, a BGP routing process and autonomous system can support multiple concurrent BGP address family and subaddress family configurations.

Information About Cisco BGP

To deploy and configure BGP in your network, you should understand the following concepts:

- [BGP Version 4 Functional Overview, page 2](#)
- [BGP Autonomous Systems, page 3](#)
- [BGP Autonomous System Number Formats, page 4](#)
- [Classless Interdomain Routing, page 6](#)
- [Multiprotocol BGP, page 7](#)
- [Benefits of Using Multiprotocol BGP Versus BGP, page 7](#)
- [Multiprotocol BGP Extensions for IP Multicast, page 7](#)
- [NLRI Configuration CLI, page 9](#)
- [Cisco BGP Address Family Model, page 9](#)
- [IPv4 Address Family, page 12](#)
- [IPv6 Address Family, page 12](#)
- [CLNS Address Family, page 12](#)
- [VPNv4 Address Family, page 13](#)
- [L2VPN Address Family, page 13](#)
- [BGP CLI Removal Considerations, page 14](#)

BGP Version 4 Functional Overview

BGP is an interdomain routing protocol designed to provide loop-free routing links between organizations. BGP is designed to run over a reliable transport protocol; it uses TCP (Port 179) as the transport protocol because TCP is a connection-oriented protocol. The destination TCP port is assigned 179, and the local port assigned a random port number. Cisco IOS software supports BGP version 4 and

it is this version that has been used by Internet Service Providers to help build the Internet. RFC 1771 introduced and discussed a number of new BGP features to allow the protocol to scale for Internet use. RFC 2858 introduced multiprotocol extensions to allow BGP to carry routing information for IP multicast routes and multiple Layer 3 protocol address families including IPv4, IPv6, and CLNS.

BGP is mainly used to connect a local network to an external network to gain access to the Internet or to connect to other organizations. When connecting to an external organization, external BGP (eBGP) peering sessions are created. Although BGP is referred to as an exterior gateway protocol (EGP) many networks within an organization are becoming so complex that BGP can be used to simplify the internal network used within the organization. BGP peers within the same organization exchange routing information through internal BGP (iBGP) peering sessions. For more details about configuring BGP peer sessions and other tasks to build a basic BGP network, see the [“Configuring a Basic BGP Network”](#) module.

BGP uses a path-vector routing algorithm to exchange network reachability information with other BGP speaking networking devices. Network reachability information is exchanged between BGP peers in routing updates. Network reachability information contains the network number, path specific attributes, and the list of autonomous system numbers that a route must transit through to reach a destination network. This list is contained in the AS-path attribute. BGP prevents routing loops by rejecting any routing update that contains the local autonomous system number because this indicates that the route has already travelled through that autonomous system and a loop would therefore be created. The BGP path-vector routing algorithm is a combination of the distance-vector routing algorithm and the AS-path loop detection. For more details about configuration tasks to configure various options involving BGP neighbor peer sessions, see the [“Configuring BGP Neighbor Session Options”](#) module.

BGP selects a single path, by default, as the best path to a destination host or network. The best path selection algorithm analyzes path attributes to determine which route is installed as the best path in the BGP routing table. Each path carries well-known mandatory, well-known discretionary, and optional transitive attributes that are used in BGP best path analysis. Cisco IOS software provides the ability to influence BGP path selection by altering some of these attributes using the command-line interface (CLI.) BGP path selection can also be influenced through standard BGP policy configuration. For more details about using BGP to influence path selection and configuring BGP policies to filter traffic, see the [“Connecting to a Service Provider Using External BGP”](#) module.

BGP can be used to help manage complex internal networks by interfacing with Interior Gateway Protocols (IGPs). Internal BGP can help with issues such as scaling the existing IGPs to match the traffic demands while maintaining network efficiency. For more details about configuring advanced BGP features including tasks to configure iBGP peering sessions, see the [“Configuring Advanced BGP Features”](#) module.

BGP Autonomous Systems

An autonomous system is a network controlled by a single technical administration entity. BGP autonomous systems are used to divide global external networks into individual routing domains where local routing policies are applied. This organization simplifies routing domain administration and simplifies consistent policy configuration. Consistent policy configuration is important to allow BGP to efficiently process routes to destination networks.

Each routing domain can support multiple routing protocols. However, each routing protocol is administrated separately. Other routing protocols can dynamically exchange routing information with BGP through redistribution. Separate BGP autonomous systems dynamically exchange routing information through eBGP peering sessions. BGP peers within the same autonomous system exchange routing information through iBGP peering sessions.

Figure 1 illustrates two routers in separate autonomous systems that can be connected using BGP. Router A and Router B are Internet service provider (ISP) routers in separate routing domains that use public autonomous system numbers. These routers carry traffic across the Internet. Router A and Router B are connected through eBGP peering sessions.

Figure 1 BGP Topology with Two Autonomous Systems

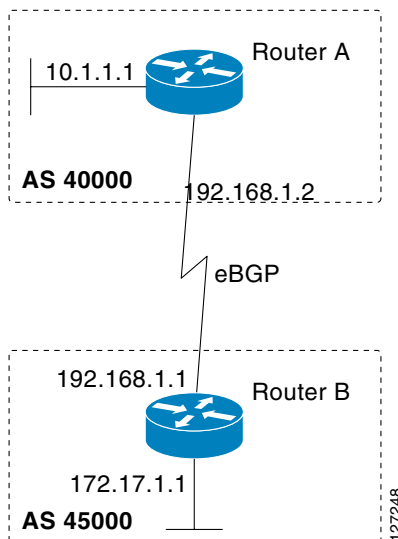

Each public autonomous system that directly connects to the Internet is assigned a unique number that identifies both the BGP routing process and the autonomous system.

BGP Autonomous System Number Formats

Prior to January 2009, BGP autonomous system numbers that were allocated to companies were 2-octet numbers in the range from 1 to 65535 as described in RFC 4271, *A Border Gateway Protocol 4 (BGP-4)*. Due to increased demand for autonomous system numbers, the Internet Assigned Number Authority (IANA) will start in January 2009 to allocate four-octet autonomous system numbers in the range from 65536 to 4294967295. RFC 5396, *Textual Representation of Autonomous System (AS) Numbers*, documents three methods of representing autonomous system numbers. Cisco has implemented the following two methods:

- **Asplain**—Decimal value notation where both 2-byte and 4-byte autonomous system numbers are represented by their decimal value. For example, 65526 is a 2-byte autonomous system number and 234567 is a 4-byte autonomous system number.
- **Asdot**—Autonomous system dot notation where 2-byte autonomous system numbers are represented by their decimal value and 4-byte autonomous system numbers are represented by a dot notation. For example, 65526 is a 2-byte autonomous system number and 1.169031 is a 4-byte autonomous system number (this is dot notation for the 234567 decimal number).

For details about the third method of representing autonomous system numbers, see RFC 5396.

Asdot Only Autonomous System Number Formatting

In Cisco IOS Release 12.0(32)S12, 12.4(24)T, Cisco IOS XE Release 2.3, and later releases, the 4-octet (4-byte) autonomous system numbers are entered and displayed only in asdot notation, for example, 1.10 or 45000.64000. When using regular expressions to match 4-byte autonomous system numbers the asdot

format includes a period which is a special character in regular expressions. A backslash must be entered before the period for example, 1\.14, to ensure the regular expression match does not fail. Table 1 shows the format in which 2-byte and 4-byte autonomous system numbers are configured, matched in regular expressions, and displayed in **show** command output in Cisco IOS images where only asdot formatting is available.

Table 1 Asdot Only 4-Byte Autonomous System Number Format

Format	Configuration Format	Show Command Output and Regular Expression Match Format
asdot	2-byte: 1 to 65535 4-byte: 1.0 to 65535.65535	2-byte: 1 to 65535 4-byte: 1.0 to 65535.65535

Asplain as Default Autonomous System Number Formatting

In Cisco IOS Release 12.0(32)SY8, 12.0(33)S3, 12.2(33)SX11, and later releases, the Cisco implementation of 4-byte autonomous system numbers uses asplain as the default display format for autonomous system numbers, but you can configure 4-byte autonomous system numbers in both the asplain and asdot format. In addition, the default format for matching 4-byte autonomous system numbers in regular expressions is asplain, so you must ensure that any regular expressions to match 4-byte autonomous system numbers are written in the asplain format. If you want to change the default **show** command output to display 4-byte autonomous system numbers in the asdot format, use the **bgp asnotation dot** command under router configuration mode. When the asdot format is enabled as the default, any regular expressions to match 4-byte autonomous system numbers must be written using the asdot format, or the regular expression match will fail. Table 2 and Table 3 show that although you can configure 4-byte autonomous system numbers in either asplain or asdot format, only one format is used to display **show** command output and control 4-byte autonomous system number matching for regular expressions, and the default is asplain format. To display 4-byte autonomous system numbers in **show** command output and to control matching for regular expressions in the asdot format, you must configure the **bgp asnotation dot** command. After enabling the **bgp asnotation dot** command, a hard reset must be initiated for all BGP sessions by entering the **clear ip bgp *** command.



Note

If you are upgrading to an image that supports 4-byte autonomous system numbers, you can still use 2-byte autonomous system numbers. The **show** command output and regular expression match are not changed and remain in asplain (decimal value) format for 2-byte autonomous system numbers regardless of the format configured for 4-byte autonomous system numbers.

Table 2 Default Asplain 4-Byte Autonomous System Number Format

Format	Configuration Format	Show Command Output and Regular Expression Match Format
asplain	2-byte: 1 to 65535 4-byte: 65536 to 4294967295	2-byte: 1 to 65535 4-byte: 65536 to 4294967295
asdot	2-byte: 1 to 65535 4-byte: 1.0 to 65535.65535	2-byte: 1 to 65535 4-byte: 65536 to 4294967295

Table 3 *Asdot 4-Byte Autonomous System Number Format*

Format	Configuration Format	Show Command Output and Regular Expression Match Format
asplain	2-byte: 1 to 65535 4-byte: 65536 to 4294967295	2-byte: 1 to 65535 4-byte: 1.0 to 65535.65535
asdot	2-byte: 1 to 65535 4-byte: 1.0 to 65535.65535	2-byte: 1 to 65535 4-byte: 1.0 to 65535.65535

Reserved and Private Autonomous System Numbers

In Cisco IOS Release 12.0(32)S12, 12.0(32)SY8, 12.0(33)S3, 12.2(33)SX11, 12.4(24)T, Cisco IOS XE Release 2.3 and later releases, the Cisco implementation of BGP supports RFC 4893. RFC 4893 was developed to allow BGP to support a gradual transition from 2-byte autonomous system numbers to 4-byte autonomous system numbers. A new reserved (private) autonomous system number, 23456, was created by RFC 4893 and this number cannot be configured as an autonomous system number in the Cisco IOS CLI.

RFC 5398, *Autonomous System (AS) Number Reservation for Documentation Use*, describes new reserved autonomous system numbers for documentation purposes. Use of the reserved numbers allow configuration examples to be accurately documented and avoids conflict with production networks if these configurations are literally copied. The reserved numbers are documented in the IANA autonomous system number registry. Reserved 2-byte autonomous system numbers are in the contiguous block, 64496 to 64511 and reserved 4-byte autonomous system numbers are from 65536 to 65551 inclusive.

Private 2-byte autonomous system numbers are still valid in the range from 64512 to 65534 with 65535 being reserved for special use. Private autonomous system numbers can be used for internal routing domains but must be translated for traffic that is routed out to the Internet. BGP should not be configured to advertise private autonomous system numbers to external networks. Cisco IOS software does not remove private autonomous system numbers from routing updates by default. We recommend that ISPs filter private autonomous system numbers.

**Note**

Autonomous system number assignment for public and private networks is governed by the IANA. For information about autonomous-system numbers, including reserved number assignment, or to apply to register an autonomous system number, see the following URL: <http://www.iana.org/>.

Classless Interdomain Routing

BGP version 4 supports classless interdomain routing (CIDR). CIDR eliminates classful network boundaries, providing more efficient usage of the IPv4 address space. CIDR provides a method to reduce the size of routing tables by configuring aggregate routes (or supernets). CIDR processes a prefix as an IP address and bit mask (bits are processed from left to right) to define each network. A prefix can represent a network, subnetwork, supernet, or single host route. For example, using classful IP addressing, the IP address 192.168.2.1 is defined as a single host in the Class C network 192.168.2.0. Using CIDR the IP address can be shown as 192.168.2.1/16, which defines a network (or supernet) of 192.168.0.0. CIDR is enabled by default for all routing protocols in Cisco IOS software. Enabling CIDR affects how packets are forwarded but it does not change the operation of BGP.

Multiprotocol BGP

Cisco IOS software supports multiprotocol BGP extensions as defined in RFC 2858, *Multiprotocol Extensions for BGP-4*. The extensions introduced in this RFC allow BGP to carry routing information for multiple network layer protocols including CLNS, IPv4, IPv6, and VPNv4. These extensions are backward compatible to enable routers that do not support multiprotocol extensions to communicate with those routers that do support multiprotocol extensions. Multiprotocol BGP carries routing information for multiple network layer protocols and IP multicast routes. BGP carries different sets of routes depending on the protocol. For example, BGP can carry one set of routes for IPv4 unicast routing, one set of routes for IPv4 multicast routing, and one set of routes for MPLS VPNv4 routes.

**Note**

A multiprotocol BGP network is backwards compatible with a BGP network but BGP peers that do not support multiprotocol extensions cannot forward routing information, such as address family identifier information, that the multiprotocol extensions carry.

Benefits of Using Multiprotocol BGP Versus BGP

In complex networks with multiple network layer protocols, multiprotocol BGP must be used. In less complex networks we recommend using multiprotocol BGP because it offers the following benefits:

- All of the BGP commands and routing policy capabilities of BGP can be applied to multiprotocol BGP.
- A network can carry routing information for multiple network layer protocol address families (for example, IP Version 4 or VPN Version 4) as specified in RFC 1700, *Assigned Numbers*.
- A network can support incongruent unicast and multicast topologies.
- A multiprotocol BGP network is backward compatible because the routers that support the multiprotocol extensions can interoperate with routers that do not support the extensions.

In summary, multiprotocol BGP support for multiple network layer protocol address families provides a flexible and scalable infrastructure that allows you to define independent policy and peering configurations on a per-address family basis.

Multiprotocol BGP Extensions for IP Multicast

The routes associated with multicast routing are used by the Protocol Independent Multicast (PIM) feature to build data distribution trees. Multiprotocol BGP is useful when you want a link dedicated to multicast traffic, perhaps to limit which resources are used for which traffic. For example, you want all multicast traffic exchanged at one network access point (NAP). Multiprotocol BGP allows you to have a unicast routing topology different from a multicast routing topology that allows you more control over your network and resources.

In BGP, the only way to perform interdomain multicast routing is to use the BGP infrastructure that is in place for unicast routing. If the routers are not multicast-capable, or there are differing policies about where multicast traffic should flow, multicast routing cannot be supported without multiprotocol BGP.

A multicast routing protocol, such as PIM, uses both the multicast and unicast BGP database to source the route, perform Reverse Path Forwarding (RPF) lookups for multicast-capable sources, and build a multicast distribution tree (MDT). The multicast table is the primary source for the router, but if the route is not found in the multicast table then the unicast table is searched. Although multicast can be performed with unicast BGP, multicast BGP routes allow an alternative topology to be used for RPF.

It is possible to configure BGP peers that exchange both unicast and multicast Network Layer Reachability Information (NLRI) where multiprotocol BGP routes can be redistributed into BGP. Multiprotocol extensions, however, will be ignored by any peers that do not support multiprotocol BGP. When PIM builds a multicast distribution tree through a unicast BGP network (because the route through the unicast network is the most attractive), the RPF check may fail, preventing the MDT from being built. If the unicast network runs multiprotocol BGP, peering can be configured using the appropriate multicast address family. The multicast address family configuration enables multiprotocol BGP to carry the multicast information and the RPF lookup will succeed.

Figure 2 illustrates a simple example of unicast and multicast topologies that are incongruent; these topologies cannot exchange information without implementing multiprotocol BGP. Autonomous systems 100, 200, and 300 are each connected to two NAPs that are FDDI rings. One is used for unicast peering (and therefore the exchanging of unicast traffic). The Multicast Friendly Interconnect (MFI) ring is used for multicast peering (and therefore the exchanging of multicast traffic). Each router is unicast- and multicast-capable.

Figure 2 *Incongruent Unicast and Multicast Routes*

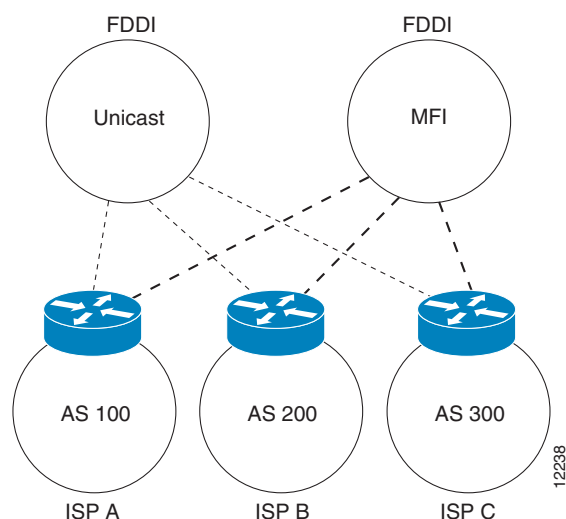
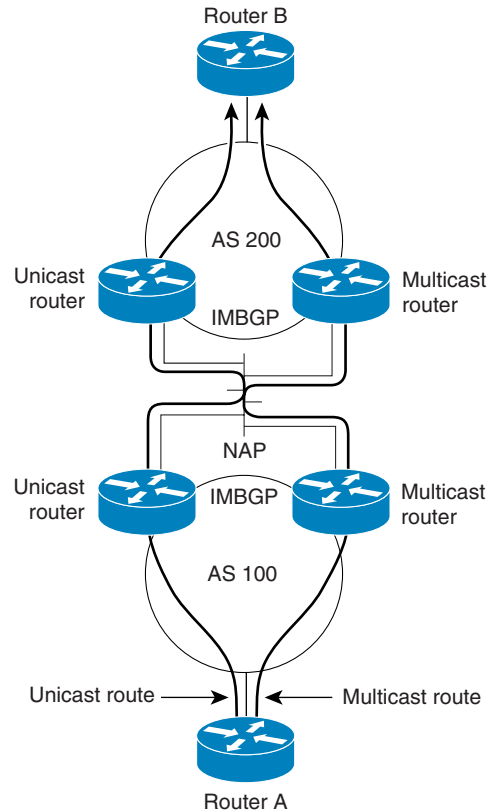

Figure 3 is a topology of unicast-only routers and multicast-only routers. The two routers on the left are unicast-only routers (that is, they do not support or are not configured to perform multicast routing). The two routers on the right are multicast-only routers. Routers A and B support both unicast and multicast routing. The unicast-only and multicast-only routers are connected to a single NAP.

In Figure 3, only unicast traffic can travel from Router A to the unicast routers to Router B and back. Multicast traffic could not flow on that path, because multicast routing is not configured on the unicast routers and therefore the BGP routing table does not contain any multicast routes. On the multicast routers, multicast routes are enabled and BGP builds a separate routing table to hold the multicast routes. Multicast traffic uses the path from Router A to the multicast routers to Router B and back.

Figure 3 illustrates a multiprotocol BGP environment with a separate unicast route and multicast route from Router A to Router B. Multiprotocol BGP allows these routes to be noncongruent. Both of the autonomous systems must be configured for internal multiprotocol BGP in the figure.

Figure 3 Multicast BGP Environment



11754

For more information about IP multicast, see the [“Configuring Basic IP Multicast”](#) module.

NLRI Configuration CLI

BGP was designed to carry only unicast IPv4 routing information. BGP configuration used the Network Layer Reachability Information (NLRI) format CLI in Cisco IOS software. The NLRI format offers only limited support for multicast routing information and does not support multiple network layer protocols. We do not recommend using NLRI format CLI for BGP configuration. Using the BGP hybrid CLI feature you can configure commands in the address family VPNv4 format and save these command configurations without modifying an existing NLRI formatted configuration. If you want to use other address family configurations such as IPv4 unicast or multicast, then you must upgrade the configuration using the **bgp upgrade-cli** command. For more details about using BGP hybrid CLI command, see the [“Configuring a Basic BGP Network”](#) module. See the [“Multiprotocol BGP”](#) and [“Cisco BGP Address Family Model”](#) concepts for more information about address family configuration format and the limitations of the NLRI CLI format.

Cisco BGP Address Family Model

The Cisco BGP address family identifier (AFI) model was introduced with multiprotocol BGP and is designed to be modular and scalable, and to support multiple AFI and subsequent address family identifier (SAFI) configurations. Networks are increasing in complexity and many companies are now using BGP to connect to many autonomous systems, as shown in the network topology in [Figure 4](#). Each

of the separate autonomous systems shown in Figure 4 may be running several routing protocols such as Multiprotocol Label Switching (MPLS) and IPv6 and require both unicast and multicast routes to be transported via BGP.

Figure 4 BGP Network Topology for Multiple Address Families

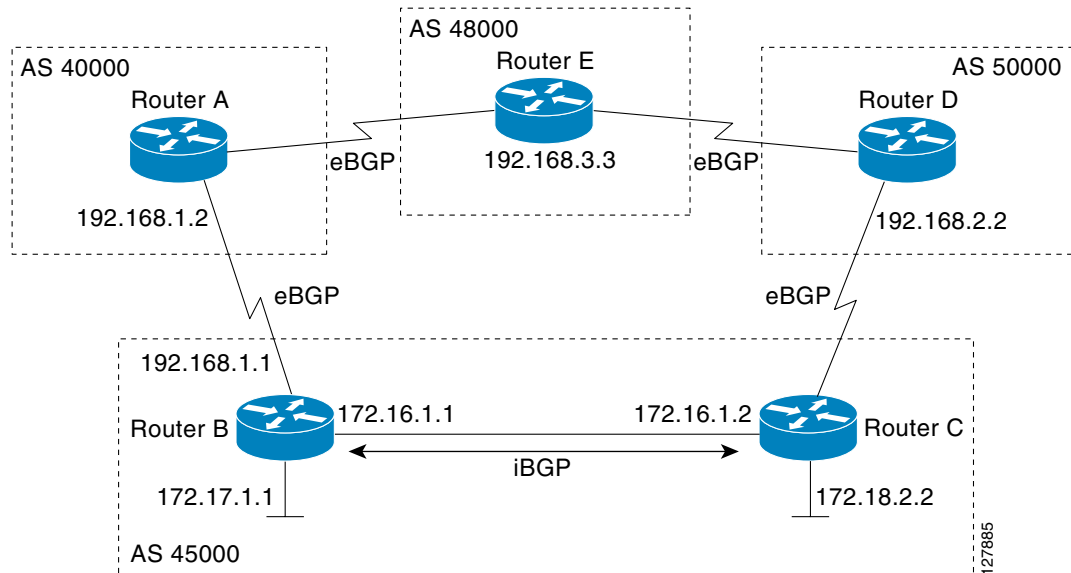

The Cisco BGP AFI model introduced new command-line interface (CLI) commands supported by a new internal structure. Multiprotocol BGP carries routing information for multiple network layer protocols and IP multicast routes. This routing information is carried in the AFI model as appended BGP attributes (multiprotocol extensions). Each address family maintains a separate BGP database, which allows you to configure BGP policy on per-address family basis. SAFI configurations are subsets of the parent AFI. SAFIs can be used to refine BGP policy configurations.

The AFI model was created because of scalability limitations of the NLRI format. A router that is configured in NLRI format has IPv4 unicast but limited multicast capabilities. Networks that are configured in the NLRI format have the following limitations:

- No support for AFI and SAFI configuration information. Many new BGP (and other protocols such as MPLS) features are supported only in AFI and SAFI configuration modes and cannot be configured in NLRI configuration modes.
- No support for IPv6. A router that is configured in the NLRI format cannot establish peering with an IPv6 neighbor.
- Limited support for multicast interdomain routing and incongruent multicast and unicast topologies. In the NLRI format, not all configuration options are available and there is no support for VPNv4. The NLRI format configurations can be more complex than configurations that support the AFI model. If the routers in the infrastructure do not have multicast capabilities, or if policies differ as to where multicast traffic is configured to flow, multicast routing cannot be supported.

The AFI model in multiprotocol BGP supports multiple AFIs and SAFIs, all NLRI-based commands and policy configurations, and is backward compatible with routers that support only the NLRI format. A router that is configured using the AFI model has the following features:

- AFI and SAFI information and configurations are supported. A router that is configured using the AFI model can carry routing information for multiple network layer protocol address families (for example, IPv4 and IPv6).

- AFI configuration is similar in all address families, making the CLI syntax easier to use than the NLRI format syntax.
- All BGP routing policy capabilities and commands are supported.
- Congruent unicast and multicast topologies that have different policies (BGP filtering configurations) are supported, as are incongruent multicast and unicast topologies.
- CLNS is supported.
- Interoperation between routers that support only the NLRI format (AFI-based networks are backward compatible) is supported. This includes both IPv4 unicast and multicast NLRI peers.
- Virtual Private Networks (VPNs) and VPN routing and forwarding (VRF) instances are supported. Unicast IPv4 for VRFs can be configured from a specific address family IPv4 VRF; this configuration update is integrated into the BGP VPNv4 database.

Within a specific address family configuration mode, the question mark (?) online help function can be used to display supported commands. The BGP commands supported in address family configuration mode configure the same functionality as the BGP commands supported in router configuration mode; however, the BGP commands in router configuration mode configure functionality only for the IPv4 unicast address prefix. To configure BGP commands and functionality for other address family prefixes (for example, the IPv4 multicast or IPv6 unicast address prefixes), you must enter address family configuration mode for those address prefixes.

The BGP address family model consists of four address families in Cisco IOS software; IPv4, IPv6, CLNS, and VPNv4. In Cisco IOS Release 12.2(33)SRB, and later releases, support for the L2VPN address family was introduced, and within the L2VPN address family the VPLS SAFI is supported. Within the IPv4 and IPv6 address families SAFIs such as Multicast Distribution Tree (MDT), tunnel, and VRF exist. [Table 4](#) shows the list of SAFIs supported by Cisco IOS software. To ensure compatibility between networks running all types of AFI and SAFI configuration, we recommend configuring BGP on Cisco IOS devices using the multiprotocol BGP address family model.

Table 4 SAFIs Supported by Cisco IOS Software

SAFI Field Value	Description	Reference
1	NLRI used for unicast forwarding.	RFC 2858
2	NLRI used for multicast forwarding.	RFC 2858
3	NLRI used for both unicast and multicast forwarding.	RFC 2858
4	NLRI with MPLS labels.	RFC 3107
64	Tunnel SAFI.	draft-nalawade-kapoor-tunnel-safi-01.txt
65	Virtual Private LAN Service (VPLS).	—
66	BGP MDT SAFI.	draft-nalawade-idr-mdt-safi-00.txt
128	MPLS-labeled VPN address.	RFC-ietf-l3vpn-rfc2547bis-03.txt

IPv4 Address Family

The IPv4 address family is used to identify routing sessions for protocols such as BGP that use standard IP version 4 address prefixes. Unicast or multicast address prefixes can be specified within the IPv4 address family. Routing information for address family IPv4 unicast is advertised by default when a BGP peer is configured unless the advertisement of unicast IPv4 information is explicitly turned off.

VRF instances can also be associated with IPv4 AFI configuration mode commands.

In Cisco IOS Release 12.0(28)S, the tunnel SAFI was introduced to support multipoint tunneling IPv4 routing sessions. The tunnel SAFI is used to advertise the tunnel endpoints and the SAFI specific attributes that contain the tunnel type and tunnel capabilities. Redistribution of tunnel endpoints into the BGP IPv4 tunnel SAFI table occurs automatically when the tunnel address family is configured. However, peers need to be activated under the tunnel address family before the sessions can exchange tunnel information.

In Cisco IOS Release 12.0(29)S, the multicast distribution tree (MDT) SAFI was introduced to support multicast VPN architectures. The MDT SAFI is a transitive multicast capable connector attribute that is defined as an IPv4 address family in BGP. The MDT address family session operates as a SAFI under the IPv4 multicast address family, and is configured on provider edge (PE) routers to establish VPN peering sessions with customer edge (CE) routers that support inter-AS multicast VPN peering sessions.

IPv6 Address Family

The IPv6 address family is used to identify routing sessions for protocols such as BGP that use standard IPv6 address prefixes. Unicast or multicast address prefixes can be specified within the IPv6 address family.

**Note**

Routing information for address family IPv4 unicast is advertised by default when you configure a BGP peer unless you explicitly turn off the advertisement of unicast IPv4 information.

CLNS Address Family

The CLNS address family is used to identify routing sessions for protocols such as BGP that use standard network service access point (NSAP) address prefixes. Unicast address prefixes are the default when NSAP address prefixes are configured.

CLNS routes are used in networks where CLNS addresses are configured. This is typically a telecommunications Data Communications Network (DCN). Peering is established using IP addresses, but update messages contain CLNS routes.

For more details about configuring BGP support for CLNS, which provides the ability to scale CLNS networks, see the [“Configuring Multiprotocol BGP \(MP-BGP\) support for CLNS”](#) module.

VPNv4 Address Family

The VPNv4 multicast address family is used to identify routing sessions for protocols such as BGP that use standard VPN Version 4 address prefixes. Unicast address prefixes are the default when VPNv4 address prefixes are configured. VPNv4 routes are the same as IPv4 routes, but VPNv4 routes have a route descriptor (RD) prepended that allows replication of prefixes. It is possible to associate every different RD with a different VPN. Each VPN needs its own set of prefixes.

Companies use an IP VPN as the foundation for deploying or administering value-added services including applications and data hosting network commerce, and telephony services to business customers.

In private LANs, IP-based intranets have fundamentally changed the way companies conduct their business. Companies are moving their business applications to their intranets to extend over a WAN. Companies are also addressing the needs of their customers, suppliers, and partners by using extranets (an intranet that encompasses multiple businesses). With extranets, companies reduce business process costs by facilitating supply-chain automation, electronic data interchange (EDI), and other forms of network commerce. To take advantage of this business opportunity, service providers must have an IP VPN infrastructure that delivers private network services to businesses over a public infrastructure.

VPNs, when used with MPLS, allow several sites to transparently interconnect through a service provider's network. One service provider network can support several different IP VPNs. Each of these appears to its users as a private network, separate from all other networks. Within a VPN, each site can send IP packets to any other site in the same VPN. Each VPN is associated with one or more VPN VRFs. The router maintains a separate routing and Cisco Express Forwarding (CEF) table for each VRF. This prevents information from being sent outside the VPN and allows the same subnet to be used in several VPNs without causing duplicate IP address problems. The router using BGP distributes the VPN routing information using the BGP extended communities.

The VPN address space is isolated from the global address space by design. BGP distributes reachability information for VPN-IPv4 prefixes for each VPN using the VPNv4 multiprotocol extensions to ensure that the routes for a given VPN are learned only by other members of that VPN, enabling members of the VPN to communicate with each other.

RFC 3107 specifies how to add label information to multiprotocol BGP address families using a SAFI. The Cisco IOS implementation of MPLS uses RFC 3107 to provide support for sending IPv4 routes with a label. VPNv4 routes implicitly have a label associated with each route.

L2VPN Address Family

In Cisco IOS Release 12.2(33)SRB and later releases, support for the L2VPN address family is introduced. L2VPN is defined as a secure network that operates inside an unsecured network by using an encryption technology such as IP security (IPsec) or Generic Routing Encapsulation (GRE). The L2VPN address family is configured under BGP routing configuration mode, and within the L2VPN address family the VPLS subsequent address family identifier (SAFI) is supported.

BGP support for the L2VPN address family introduces a BGP-based autodiscovery mechanism to distribute L2VPN endpoint provisioning information. BGP uses a separate L2VPN routing information base (RIB) to store endpoint provisioning information, which is updated each time any Layer 2 VFI is configured. Prefix and path information is stored in the L2VPN database, allowing BGP to make best-path decisions. When BGP distributes the endpoint provisioning information in an update message to all its BGP neighbors, the endpoint information is used to set up a pseudowire mesh to support L2VPN-based services.

The BGP autodiscovery mechanism facilitates the setting up of L2VPN services, which are an integral part of the Cisco IOS Virtual Private LAN Service (VPLS) feature. VPLS enables flexibility in deploying services by connecting geographically dispersed sites as a large LAN over high-speed Ethernet in a robust and scalable IP MPLS network. For more details about VPLS, see the [VPLS Autodiscovery: BGP Based](#) feature.

Under L2VPN address family the following BGP command-line interface (CLI) commands are supported:

- **bgp scan-time**
- **bgp nexthop**
- **neighbor activate**
- **neighbor advertisement-interval**
- **neighbor allowas-in**
- **neighbor capability**
- **neighbor inherit**
- **neighbor peer-group**
- **neighbor maximum-prefix**
- **neighbor next-hop-self**
- **neighbor next-hop-unchanged**
- **neighbor remove-private-as**
- **neighbor route-map**
- **neighbor route-reflector-client**
- **neighbor send-community**
- **neighbor soft-reconfiguration**
- **neighbor soo**
- **neighbor weight**

**Note**

For route reflectors using L2VPNs, the **neighbor next-hop-self** and **neighbor next-hop-unchanged** commands are not supported.

For route maps used within BGP, all commands related to prefix processing, tag processing, and automated tag processing are ignored when used under L2VPN address family configuration. All other route map commands are supported.

BGP multipaths and confederations are not supported under the L2VPN address family.

For details on configuring BGP under the L2VPN address family, see the [BGP Support for the L2VPN Address Family](#) feature in Cisco IOS Release 12.2(33)SRB.

BGP CLI Removal Considerations

BGP CLI configuration can become quite complex even in smaller BGP networks. If you need to remove any CLI configuration, you must consider all the implications of removing the CLI. Analyze the current running configuration to determine the current BGP neighbor relationships, any address family considerations, and even other routing protocols that are configured. Many BGP CLI commands affect

other parts of the CLI configuration. For example, in the following configuration, a route map is used to match a BGP autonomous system number and then set the matched routes with another autonomous system number for EIGRP.

```
route-map bgp-to-eigrp permit 10
  match tag 50000
  set tag 65000
```

BGP neighbors in three different autonomous systems are configured and activated.

```
router bgp 45000
  bgp log-neighbor-changes
  address-family ipv4
    neighbor 172.16.1.2 remote-as 45000
    neighbor 192.168.1.2 remote-as 40000
    neighbor 192.168.3.2 remote-as 50000
    neighbor 172.16.1.2 activate
    neighbor 192.168.1.2 activate
    neighbor 192.168.3.2 activate
  network 172.17.1.0 mask 255.255.255.0
  exit-address-family
```

An EIGRP routing process is then configured and BGP routes are redistributed into EIGRP with a route map filtering the routes.

```
router eigrp 100
  redistribute bgp 45000 metric 10000 100 255 1 1500 route-map bgp-to-eigrp
  no auto-summary
  exit
```

If you later decide to remove the route map you will use the **no** form of the **route-map** command. Almost every configuration command has a **no** form, and the **no** form generally disables a function. However, in this CLI configuration example, if you just disable the route map, the route redistribution will continue, but without the filtering or matching from the route map. Redistribution without the route map may cause unexpected results in your network. Any configuration command that incorporates another command type such as an access list or route map must be reviewed to see if the command must also be removed or modified to mitigate the effect of the removal of the incorporated command.

The following CLI configuration will remove both the route map and the redistribution.

```
configure terminal
  no route-map bgp-to-eigrp
  router eigrp 100
    no redistribute bgp 45000
  end
```

For details on configuring the removal of BGP CLI configuration, see the [“Configuring a Basic BGP Network”](#) module.

Where to Go Next

Proceed to the [“Configuring a Basic BGP Network”](#) module.

Additional References

The following sections provide references related to configuring BGP.

Related Documents

Related Topic	Document Title
BGP commands	Cisco IOS IP Routing Protocols Command Reference
Configuring basic BGP tasks	“Configuring a Basic BGP Network” module
Configuring BGP neighbor session options	“Configuring BGP Neighbor Session Options” module
Configuring BGP to connect to a service provider	“Connecting to a Service Provider Using External BGP” module
Configuring internal BGP (iBGP) tasks	“Configuring Internal BGP Features” module
Configuring advanced BGP features	“Configuring Advanced BGP Features” module
Configuring Multiprotocol BGP with CLNS	“Configuring Multiprotocol BGP (MP-BGP) Support for CLNS” module
Configuring basic IP multicast tasks	“Configuring Basic IP Multicast” module

Standards

Standard	Title
MDT SAFI	MDT SAFI

MIBs

MIB	MIBs Link
CISCO-BGP4-MIB	To locate and download MIBs for selected platforms, Cisco IOS releases, and feature sets, use Cisco MIB Locator found at the following URL: http://www.cisco.com/go/mibs

RFCs

RFC	Title
RFC 1700	<i>Assigned Numbers</i>
RFC 2858	<i>Multiprotocol Extensions for BGP-4</i>
RFC 3107	<i>Carrying Label Information in BGP-4</i>
RFC 4271	<i>A Border Gateway Protocol 4 (BGP-4)</i>
RFC 4893	<i>BGP Support for Four-Octet AS Number Space</i>

RFC	Title
RFC 5396	<i>Textual Representation of Autonomous System (AS) Numbers</i>
RFC 5398	<i>Autonomous System (AS) Number Reservation for Documentation Use</i>

Technical Assistance

Description	Link
<p>The Cisco Support website provides extensive online resources, including documentation and tools for troubleshooting and resolving technical issues with Cisco products and technologies.</p> <p>To receive security and technical information about your products, you can subscribe to various services, such as the Product Alert Tool (accessed from Field Notices), the Cisco Technical Services Newsletter, and Really Simple Syndication (RSS) Feeds.</p> <p>Access to most tools on the Cisco Support website requires a Cisco.com user ID and password.</p>	<p>http://www.cisco.com/techsupport</p>

Feature Information for Cisco BGP Overview

Table 5 lists the features in this module and provides links to specific configuration information. Only features that were introduced or modified in Cisco IOS Releases 12.2(33)SRB, 12.0(32)S12, 12.4(24)T, 12.2(33)SXII, or a later release appear in the table.

Not all commands may be available in your Cisco IOS software release. For release information about a specific command, see the command reference documentation.

Use Cisco Feature Navigator to find information about platform support and software image support. Cisco Feature Navigator enables you to determine which Cisco IOS and Catalyst OS software images support a specific software release, feature set, or platform. To access Cisco Feature Navigator, go to <http://www.cisco.com/go/cfn>. An account on Cisco.com is not required.

**Note**

Table 5 lists only the Cisco IOS software release that introduced support for a given feature in a given Cisco IOS software release train. Unless noted otherwise, subsequent releases of that Cisco IOS software release train also support that feature.

Table 5 Feature Information for Cisco BGP Overview

Feature Name	Releases	Feature Information
BGP Support for 4-Byte ASN	12.0(32)S12 12.0(32)SY8 12.0(33)S3 12.2(33)SX11 12.4(24)T Cisco IOS XE Release 2.3	<p>The BGP Support for 4-Byte ASN feature introduced support for 4-byte autonomous system numbers. Because of increased demand for autonomous system numbers, in January 2009 the IANA will start to allocate 4-byte autonomous system numbers in the range from 65536 to 4294967295.</p> <p>In Cisco IOS Release 12.0(32)SY8, 12.0(33)S3, and 12.2(33)SX11, the Cisco implementation of 4-byte autonomous system numbers uses asplain as the default regular expression match and output display format for autonomous system numbers, but you can configure 4-byte autonomous system numbers in both the asplain format and the asdot format as described in RFC 5396. To change the default regular expression match and output display of 4-byte autonomous system numbers to asdot format, use the bgp asnotation dot command.</p> <p>In Cisco IOS Release 12.0(32)S12, 12.4(24)T, and Cisco IOS XE Release 2.3, the Cisco implementation of 4-byte autonomous system numbers uses asdot as the only configuration format, regular expression match, and output display, with no asplain support.</p> <p>The following sections provide information about this feature:</p> <ul style="list-style-type: none"> • BGP Autonomous System Number Formats, page 4 <p>The following commands were introduced or modified by this feature: bgp asnotation dot, bgp confederation identifier, bgp confederation peers, all clear ip bgp commands that configure an autonomous system number, ip as-path access-list, ip extcommunity-list, match source-protocol, neighbor local-as, neighbor remote-as, redistribute (IP), router bgp, route-target, set as-path, set extcommunity, set origin, all show ip bgp commands that display an autonomous system number, and show ip extcommunity-list.</p>

Table 5 Feature Information for Cisco BGP Overview (continued)

Feature Name	Releases	Feature Information
BGP Support for the L2VPN Address Family	12.2(33)SRB	<p>BGP Support for the L2VPN address family introduced a BGP-based autodiscovery mechanism to distribute L2VPN endpoint provisioning information. BGP uses a separate L2VPN routing information base (RIB) to store endpoint provisioning information which is updated each time any Layer 2 VFI is configured. When BGP distributes the endpoint provisioning information in an update message to all its BGP neighbors, the endpoint information is used to set up a Pseudowire mesh to support L2VPN-based services.</p> <p>The following section provides information about this feature:</p> <ul style="list-style-type: none"> • Cisco BGP Address Family Model, page 9 • L2VPN Address Family, page 13 <p>The following commands were introduced or modified by this feature: address-family l2vpn, show ip bgp l2vpn.</p>
Configuring Multiprotocol BGP Support for CLNS	12.2(33)SRB	<p>The Multiprotocol BGP (MP-BGP) Support for CLNS feature provides the ability to scale Connectionless Network Service (CLNS) networks. The multiprotocol extensions of Border Gateway Protocol (BGP) add the ability to interconnect separate Open System Interconnection (OSI) routing domains without merging the routing domains, thus providing the capability to build very large OSI networks.</p> <p>The following section provides information about this feature:</p> <ul style="list-style-type: none"> • Cisco BGP Address Family Model, page 9 • CLNS Address Family, page 12 <p>The following commands were introduced or modified by this feature: clear bgp nsap, clear bgp nsap dampening, clear bgp nsap external, clear bgp nsap flap-statistics, clear bgp nsap peer-group, debug bgp nsap, debug bgp nsap dampening, debug bgp nsap updates, neighbor prefix-list, network (BGP and multiprotocol BGP), redistribute (BGP to ISO ISIS), redistribute (ISO ISIS to BGP), show bgp nsap, show bgp nsap community, show bgp nsap community-list, show bgp nsap dampened-paths, show bgp nsap filter-list, show bgp nsap flap-statistics, show bgp nsap inconsistent-as, show bgp nsap neighbors, show bgp nsap paths, show bgp nsap quote-regexp, show bgp nsap regexp, show bgp nsap summary.</p>

CCDE, CCSI, CCENT, Cisco Eos, Cisco HealthPresence, the Cisco logo, Cisco Lumin, Cisco Nexus, Cisco Nurse Connect, Cisco Stackpower, Cisco StadiumVision, Cisco TelePresence, Cisco WebEx, DCE, and Welcome to the Human Network are trademarks; Changing the Way We Work, Live, Play, and Learn and Cisco Store are service marks; and Access Registrar, Aironet, AsyncOS, Bringing the Meeting To You, Catalyst, CCDA,

CCDP, CCIE, CCIP, CCNA, CCNP, CCSP, CCVP, Cisco, the Cisco Certified Internetwork Expert logo, Cisco IOS, Cisco Press, Cisco Systems, Cisco Systems Capital, the Cisco Systems logo, Cisco Unity, Collaboration Without Limitation, EtherFast, EtherSwitch, Event Center, Fast Step, Follow Me Browsing, FormShare, GigaDrive, HomeLink, Internet Quotient, IOS, iPhone, iQuick Study, IronPort, the IronPort logo, LightStream, Linksys, MediaTone, MeetingPlace, MeetingPlace Chime Sound, MGX, Networkers, Networking Academy, Network Registrar, PCNow, PIX, PowerPanels, ProConnect, ScriptShare, SenderBase, SMARTnet, Spectrum Expert, StackWise, The Fastest Way to Increase Your Internet Quotient, TransPath, WebEx, and the WebEx logo are registered trademarks of Cisco Systems, Inc. and/or its affiliates in the United States and certain other countries.

All other trademarks mentioned in this document or website are the property of their respective owners. The use of the word partner does not imply a partnership relationship between Cisco and any other company. (0903R)

Any Internet Protocol (IP) addresses and phone numbers used in this document are not intended to be actual addresses and phone numbers. Any examples, command display output, network topology diagrams, and other figures included in the document are shown for illustrative purposes only. Any use of actual IP addresses or phone numbers in illustrative content is unintentional and coincidental.

© 2005–2009 Cisco Systems, Inc. All rights reserved.

