



# iBGP Multipath Load Sharing

---

**First Published: May 25, 2001**  
**Last Updated: March 10, 2009**

This feature module describes the iBGP Multipath Load Sharing feature.

## Finding Feature Information

Your software release may not support all the features documented in this module. For the latest feature information and caveats, see the release notes for your platform and software release. To find information about the features documented in this module, and to see a list of the releases in which each feature is supported, see the [“Feature Information for iBGP Multipath Load Sharing”](#) section on page 11.

Use Cisco Feature Navigator to find information about platform support and Cisco IOS and Catalyst OS software image support. To access Cisco Feature Navigator, go to <http://www.cisco.com/go/cfn>. An account on Cisco.com is not required.

## Contents

- [Feature Overview, page 2](#)
- [Restrictions for iBGP Multipath Load Sharing, page 2](#)
- [Configuration Tasks, page 4](#)
- [Monitoring and Maintaining iBGP Multipath Load Sharing, page 6](#)
- [Configuration Examples, page 7](#)
- [Additional References, page 8](#)
- [Command Reference, page 9](#)
- [Feature Information for iBGP Multipath Load Sharing, page 11](#)



---

**Americas Headquarters:**  
**Cisco Systems, Inc., 170 West Tasman Drive, San Jose, CA 95134-1706 USA**

© 2001–2009 Cisco Systems, Inc. All rights reserved.

## Restrictions for iBGP Multipath Load Sharing

- Route Reflector Limitation—With multiple iBGP paths installed in a routing table, a route reflector will advertise only one of the paths (one next hop).
- Memory Consumption Restriction—Each IP routing table entry for a BGP prefix that has multiple iBGP paths uses approximately 350 bytes of additional memory. We recommend not using this feature on a router with a low amount of available memory and especially when the router is carrying a full Internet routing table.
- The iBGP Multipath Load Sharing feature is supported for the following platforms in Cisco IOS Release 12.2(14)S:
  - Cisco 7200 series
  - Cisco 7400 series
  - Cisco 7500 series

## Feature Overview

When a Border Gateway Protocol (BGP) speaking router with no local policy configured receives multiple network layer reachability information (NLRI) from the internal BGP (iBGP) for the same destination, the router will choose one iBGP path as the best path. The best path is then installed in the IP routing table of the router. For example, in [Figure 1](#), although there are three paths to autonomous system 200, Router 2 determines that one of the paths to autonomous system 200 is the best path and uses this path only to reach autonomous system 200.

**Figure 1** Non-MPLS Topology with One Best Path

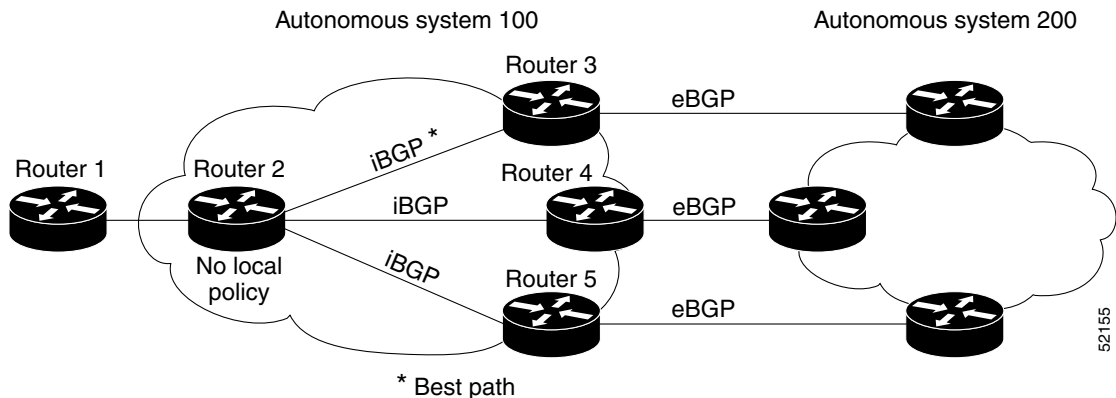

The iBGP Multipath Load Sharing feature enables the BGP speaking router to select multiple iBGP paths as the best paths to a destination. The best paths or multipaths are then installed in the IP routing table of the router. For example, on router 2 in [Figure 2](#), the paths to routers 3, 4, and 5 are configured as multipaths and can be used to reach autonomous system 200, thereby equally sharing the load to autonomous system 200.

**Figure 2 Non-MPLS Topology with Three Multipaths**

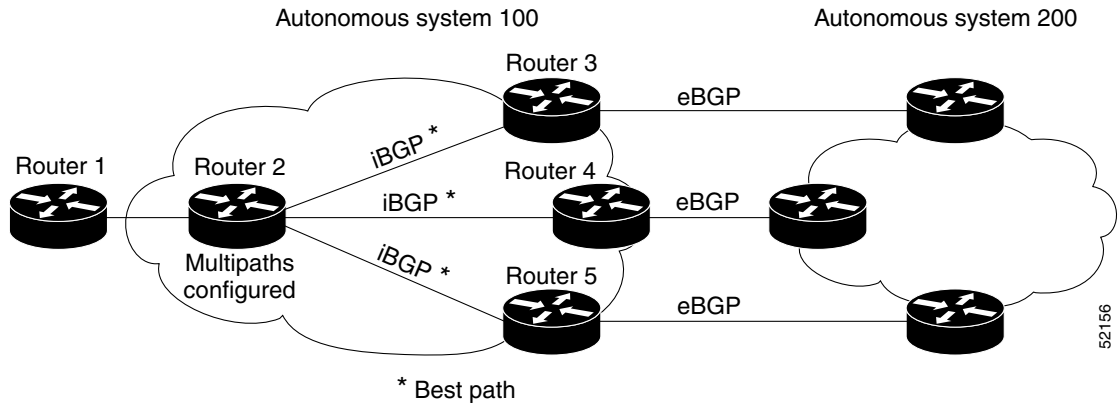

The iBGP Multipath Load Sharing feature functions similarly in a Multiprotocol Label Switching (MPLS) Virtual Private Network (VPN) with a service provider backbone. For example, on router PE1 in Figure 3, the paths to routers PE2, PE3, and PE4 can be selected as multipaths and can be used to equally share the load to site 2.

**Figure 3 MPLS VPN with Three Multipaths**

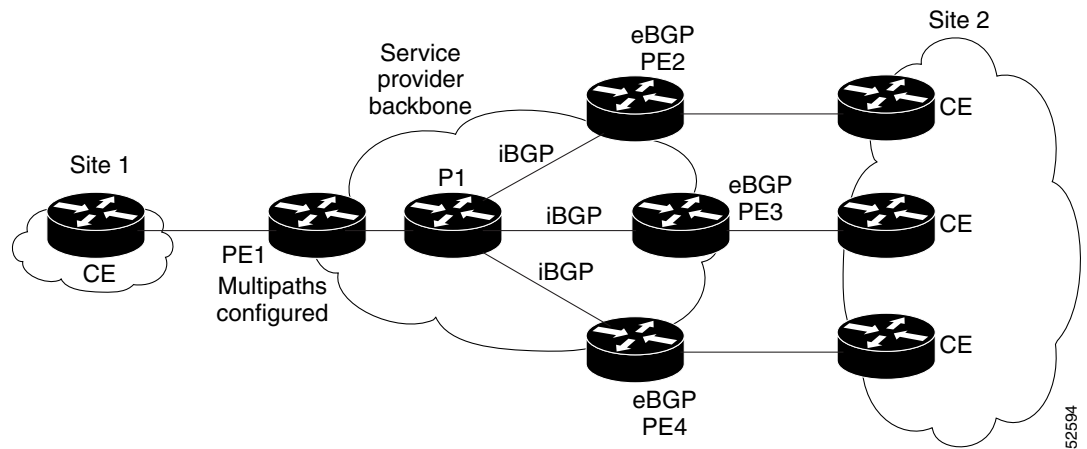

For multiple paths to the same destination to be considered as multipaths, the following criteria must be met:

- All attributes must be the same. The attributes include weight, local preference, autonomous system path (entire attribute and not just length), origin code, Multi Exit Discriminator (MED), and Interior Gateway Protocol (IGP) distance.
- The next hop router for each multipath must be different.

Even if the criteria are met and multiple paths are considered multipaths, the BGP speaking router will still designate one of the multipaths as the best path and advertise this best path to its neighbors.

## Benefits

Configuring multiple iBGP best paths enables a router to evenly share the traffic destined for a particular site.

## Related Features and Technologies

The iBGP Multipath Load Sharing feature is similar to BGP multipath support for external BGP (eBGP) paths; however, the iBGP Multipath Load Sharing feature is applied to internal rather than eBGP paths.

## Configuration Tasks

See the following sections for configuration tasks for the iBGP Multipath Load Sharing feature. Each task in the list is identified as either required or optional.

- [Configuring iBGP Multipath Load Sharing](#) (required)
- [Verifying iBGP Multipath Load Sharing](#) (optional)

## Configuring iBGP Multipath Load Sharing

To configure the iBGP Multipath Load Sharing feature, use the following command in router configuration mode:

| Command  | Purpose   |
|--|---|
| Router(config-router)# <b>maximum-paths</b> <i>ibgp</i><br><i>maximum-number</i> | Controls the maximum number of parallel iBGP routes that can be installed in a routing table. |

## Verifying iBGP Multipath Load Sharing

To verify that the iBGP Multipath Load Sharing feature is configured correctly, perform the following steps:

- Step 1** Enter the **show ip bgp network-number** EXEC command to display attributes for a network in a non-MPLS topology, or the **show ip bgp vpnv4 all ip-prefix** EXEC command to display attributes for a network in an MPLS VPN:

```
Router# show ip bgp 10.22.22.0

BGP routing table entry for 10.22.22.0/24, version 119
Paths: (6 available, best #1)
Multipath: iBGP
Flag: 0x820
  Advertised to non-peer-group peers:
    10.1.12.12
    22
    10.2.3.8 (metric 11) from 10.1.3.4 (100.0.0.5)
      Origin IGP, metric 0, localpref 100, valid, internal, multipath, best
      Originator:100.0.0.5, Cluster list:100.0.0.4
```

```

22
  10.2.1.9 (metric 11) from 10.1.1.2 (100.0.0.9)
    Origin IGP, metric 0, localpref 100, valid, internal, multipath
    Originator:100.0.0.9, Cluster list:100.0.0.2
22
  10.2.5.10 (metric 11) from 10.1.5.6 (100.0.0.10)
    Origin IGP, metric 0, localpref 100, valid, internal, multipath
    Originator:100.0.0.10, Cluster list:100.0.0.6
22
  10.2.4.10 (metric 11) from 10.1.4.5 (100.0.0.10)
    Origin IGP, metric 0, localpref 100, valid, internal, multipath
    Originator:100.0.0.10, Cluster list:100.0.0.5
22
  10.2.6.10 (metric 11) from 10.1.6.7 (100.0.0.10)
    Origin IGP, metric 0, localpref 100, valid, internal, multipath
    Originator:100.0.0.10, Cluster list:100.0.0.7

```

```
Router# show ip bgp vpnv4 all 10.22.22.0
```

```

BGP routing table entry for 100:1:10.22.22.0/24, version 50
Paths:(6 available, best #1)
Multipath:iBGP
  Advertised to non peer-group peers:
  200.1.12.12
  22
    10.22.7.8 (metric 11) from 10.11.3.4 (100.0.0.8)
      Origin IGP, metric 0, localpref 100, valid, internal, multipath, best
      Extended Community:RT:100:1
      Originator:100.0.0.8, Cluster list:100.1.1.44
  22
    10.22.1.9 (metric 11) from 10.11.1.2 (100.0.0.9)
      Origin IGP, metric 0, localpref 100, valid, internal, multipath
      Extended Community:RT:100:1
      Originator:100.0.0.9, Cluster list:100.1.1.22
  22
    10.22.6.10 (metric 11) from 10.11.6.7 (100.0.0.10)
      Origin IGP, metric 0, localpref 100, valid, internal, multipath
      Extended Community:RT:100:1
      Originator:100.0.0.10, Cluster list:100.0.0.7
  22
    10.22.4.10 (metric 11) from 10.11.4.5 (100.0.0.10)
      Origin IGP, metric 0, localpref 100, valid, internal, multipath
      Extended Community:RT:100:1
      Originator:100.0.0.10, Cluster list:100.0.0.5
  22
    10.22.5.10 (metric 11) from 10.11.5.6 (100.0.0.10)
      Origin IGP, metric 0, localpref 100, valid, internal, multipath
      Extended Community:RT:100:1
      Originator:100.0.0.10, Cluster list:100.0.0.6

```

**Step 2** In the display resulting from the **show ip bgp network-number EXEC** command or the **show ip bgp vpnv4 all ip-prefix EXEC** command, verify that the intended multipaths are marked as “multipaths.” Notice that one of the multipaths is marked as “best.”

**Step 3** Enter the **show ip route ip-address EXEC** command to display routing information for a network in a non-MPLS topology or the **show ip route vrf vrf-name ip-prefix EXEC** command to display routing information for a network in an MPLS VPN:

```
Router# show ip route 10.22.22.0
```

```

Routing entry for 10.22.22.0/24
  Known via "bgp 1", distance 200, metric 0
  Tag 22, type internal

```

```

Last update from 10.2.6.10 00:00:03 ago
Routing Descriptor Blocks:
* 10.2.3.8, from 10.1.3.4, 00:00:03 ago
  Route metric is 0, traffic share count is 1
  AS Hops 1
  10.2.1.9, from 10.1.1.2, 00:00:03 ago
    Route metric is 0, traffic share count is 1
    AS Hops 1
  10.2.5.10, from 10.1.5.6, 00:00:03 ago
    Route metric is 0, traffic share count is 1
    AS Hops 1
  10.2.4.10, from 10.1.4.5, 00:00:03 ago
    Route metric is 0, traffic share count is 1
    AS Hops 1
  10.2.6.10, from 10.1.6.7, 00:00:03 ago
    Route metric is 0, traffic share count is 1
    AS Hops 1

```

```
Router# show ip route vrf PATH 10.22.22.0
```

```

Routing entry for 10.22.22.0/24
Known via "bgp 1", distance 200, metric 0
Tag 22, type internal
Last update from 10.22.5.10 00:01:07 ago
Routing Descriptor Blocks:
* 10.22.7.8 (Default-IP-Routing-Table), from 10.11.3.4, 00:01:07 ago
  Route metric is 0, traffic share count is 1
  AS Hops 1
  10.22.1.9 (Default-IP-Routing-Table), from 10.11.1.2, 00:01:07 ago
    Route metric is 0, traffic share count is 1
    AS Hops 1
  10.22.6.10 (Default-IP-Routing-Table), from 10.11.6.7, 00:01:07 ago
    Route metric is 0, traffic share count is 1
    AS Hops 1
  10.22.4.10 (Default-IP-Routing-Table), from 10.11.4.5, 00:01:07 ago
    Route metric is 0, traffic share count is 1
    AS Hops 1
  10.22.5.10 (Default-IP-Routing-Table), from 10.11.5.6, 00:01:07 ago
    Route metric is 0, traffic share count is 1
    AS Hops 1

```

- Step 4** Verify that the paths marked as “multipath” in the display resulting from the **show ip bgp ip-prefix EXEC** command or the **show ip bgp vpnv4 all ip-prefix EXEC** command are included in the routing information. (The routing information is displayed after performing [Step 3](#).)

## Monitoring and Maintaining iBGP Multipath Load Sharing

To display iBGP Multipath Load Sharing information, use the following commands in EXEC mode, as needed:

| Command  | Purpose  |
|--|--|
| Router# <b>show ip bgp ip-prefix</b>           | Displays attributes and multipaths for a network in a non-MPLS topology. |
| Router# <b>show ip bgp vpnv4 all ip-prefix</b> | Displays attributes and multipaths for a network in an MPLS VPN.         |

| Command   | Purpose  |
|---|--|
| Router# <code>show ip route ip-prefix</code>              | Displays routing information for a network in a non-MPLS topology. |
| Router# <code>show ip route vrf vrf-name ip-prefix</code> | Displays routing information for a network in an MPLS VPN.         |

## Configuration Examples

This section provides the following configuration examples:

- [Non-MPLS Topology Example](#)
- [MPLS VPN Topology Example](#)

Both examples assume that the appropriate attributes for each path are equal and that the next hop router for each multipath is different.

### Non-MPLS Topology Example

The following example shows how to set up the iBGP Multipath Load Sharing feature in a non-MPLS topology (see [Figure 4](#)).

**Figure 4 Non-MPLS Topology Example**

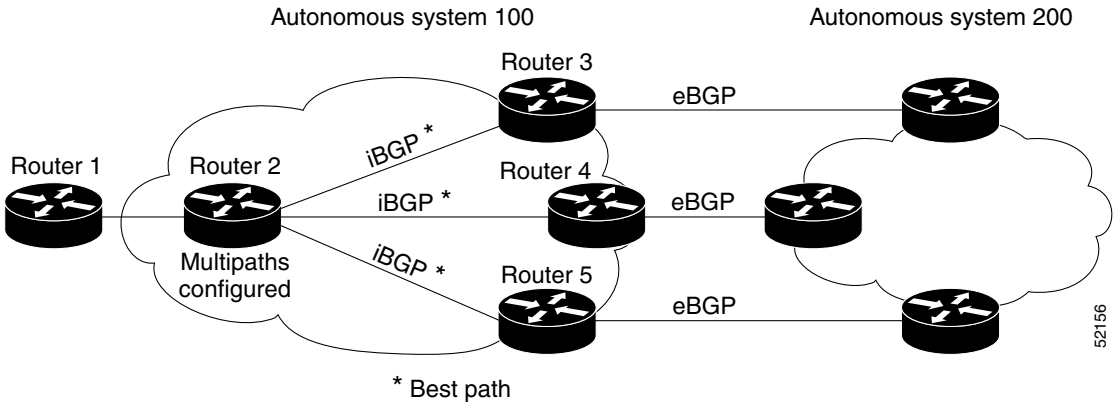

**Router 2 Configuration**

```
router bgp 100
maximum-paths ibgp 3
```

### MPLS VPN Topology Example

The following example shows how to set up the iBGP Multipath Load Sharing feature in an MPLS VPN topology (see [Figure 5](#)).

**Figure 5** *MPLS VPN Topology Example*

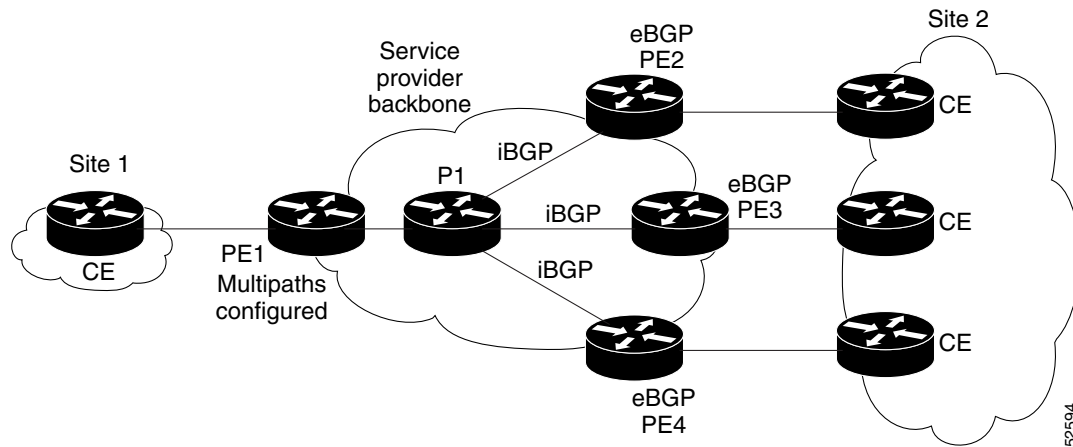

#### Router PE1 Configuration

```
router bgp 100
address-family ipv4 unicast vrf site2
maximum-paths ibgp 3
```

## Additional References

The following sections provide references related to the iBGP Multipath Load Sharing feature.

## Related Documents

| Related Topic   | Document Title   |
|---|--|
| BGP commands  | <a href="#">Cisco IOS IP Routing Protocols Command Reference</a>                 |
| Advertising the bandwidth of an autonomous system exit link as an extended community. | <a href="#">BGP Link Bandwidth</a>   |
| BGP multipath load sharing for both eBGP and iBGP in an MPLS-VPN                      | <a href="#">BGP Multipath Load Sharing for Both eBGP and iBGP in an MPLS-VPN</a> |

## Standards

| Standard  | Title |
|---|-------|
| No new or modified standards are supported by this feature, and support for existing standards has not been modified by this feature. | —     |

## MIBs

| MIB | MIBs Link  |
|-----|--|
| •   | To locate and download MIBs for selected platforms, Cisco IOS releases, and feature sets, use Cisco MIB Locator found at the following URL:<br><a href="http://www.cisco.com/go/mibs">http://www.cisco.com/go/mibs</a> |

## RFCs

| RFC  | Title |
|--|-------|
| No new or modified RFCs are supported by this feature, and support for existing standards has not been modified by this feature. | —     |

## Technical Assistance

| Description   | Link  |
|---|---|
| <p>The Cisco Support website provides extensive online resources, including documentation and tools for troubleshooting and resolving technical issues with Cisco products and technologies.</p> <p>To receive security and technical information about your products, you can subscribe to various services, such as the Product Alert Tool (accessed from Field Notices), the Cisco Technical Services Newsletter, and Really Simple Syndication (RSS) Feeds.</p> <p>Access to most tools on the Cisco Support website requires a Cisco.com user ID and password.</p> | <a href="http://www.cisco.com/techsupport">http://www.cisco.com/techsupport</a> |

## Command Reference

The following commands are introduced or modified in the feature or features documented in this module. For information about these commands, see the *Cisco IOS IP Routing Protocols Command Reference* at [http://www.cisco.com/en/US/docs/ios/iproute/command/reference/irp\\_book.html](http://www.cisco.com/en/US/docs/ios/iproute/command/reference/irp_book.html). For information about all Cisco IOS commands, go to the Command Lookup Tool at <http://tools.cisco.com/Support/CLILookup> or to the *Cisco IOS Master Commands List*.

### New Commands

- **maximum-paths ibgp**

### Modified Commands

- **show ip bgp**
- **show ip bgp vpnv4**

- **show ip route**
- **show ip route vrf**

# Feature Information for iBGP Multipath Load Sharing

Table 1 lists the features in this module and provides links to specific configuration information.

For information on a feature in this technology that is not documented here, see the [BGP Features Roadmap](#).

Not all commands may be available in your Cisco IOS software release. For release information about a specific command, see the command reference documentation.

Use Cisco Feature Navigator to find information about platform support and software image support. Cisco Feature Navigator enables you to determine which Cisco IOS and Catalyst OS software images support a specific software release, feature set, or platform. To access Cisco Feature Navigator, go to <http://www.cisco.com/go/cfn>. An account on Cisco.com is not required.



## Note

Table 1 lists only the Cisco IOS software release that introduced support for a given feature in a given Cisco IOS software release train. Unless noted otherwise, subsequent releases of that Cisco IOS software release train also support that feature.

**Table 1** Feature Information for iBGP Multipath Load Sharing

| Feature Name                | Releases              | Feature Information  |
|-----------------------------|-----------------------|--|
| iBGP Multipath Load Sharing | 12.2(14)S<br>12.2(2)T | The iBGP Multipath Load Sharing feature enables the BGP speaking router to select multiple iBGP paths as the best paths to a destination.<br><br>The following commands were introduced or modified:<br><b>maximum-paths ibgp, show ip bgp, show ip bgp vpnv4, show ip route, show ip route vrf.</b> |

CCDE, CCSI, CCENT, Cisco Eos, Cisco HealthPresence, the Cisco logo, Cisco Lumin, Cisco Nexus, Cisco Nurse Connect, Cisco Stackpower, Cisco StadiumVision, Cisco TelePresence, Cisco WebEx, DCE, and Welcome to the Human Network are trademarks; Changing the Way We Work, Live, Play, and Learn and Cisco Store are service marks; and Access Registrar, Aironet, AsyncOS, Bringing the Meeting To You, Catalyst, CCDA, CCDP, CCIE, CCIP, CCNA, CCNP, CCSP, CCVP, Cisco, the Cisco Certified Internetwork Expert logo, Cisco IOS, Cisco Press, Cisco Systems, Cisco Systems Capital, the Cisco Systems logo, Cisco Unity, Collaboration Without Limitation, EtherFast, EtherSwitch, Event Center, Fast Step, Follow Me Browsing, FormShare, GigaDrive, HomeLink, Internet Quotient, IOS, iPhone, iQuick Study, IronPort, the IronPort logo, LightStream, Linksys, MediaTone, MeetingPlace, MeetingPlace Chime Sound, MGX, Networkers, Networking Academy, Network Registrar, PCNow, PIX, PowerPanels, ProConnect, ScriptShare, SenderBase, SMARTnet, Spectrum Expert, StackWise, The Fastest Way to Increase Your Internet Quotient, TransPath, WebEx, and the WebEx logo are registered trademarks of Cisco Systems, Inc. and/or its affiliates in the United States and certain other countries.

All other trademarks mentioned in this document or website are the property of their respective owners. The use of the word partner does not imply a partnership relationship between Cisco and any other company. (0903R)

Any Internet Protocol (IP) addresses used in this document are not intended to be actual addresses. Any examples, command display output, and figures included in the document are shown for illustrative purposes only. Any use of actual IP addresses in illustrative content is unintentional and coincidental.

© 2001–2009 Cisco Systems, Inc. All rights reserved.

