



# Configuring WCCP

---

**First Published: August 21, 2007**  
**Last Updated: July 30, 2010**

The Web Cache Communication Protocol (WCCP) is a Cisco-developed content-routing technology that intercepts IP packets and redirects those packets to a destination other than that specified in the IP packet. Typically the packets are redirected from their destination web server on the Internet to a content engine that is local to the client. In some WCCP deployment scenarios, redirection of traffic may also be required from the web server to the client. WCCP enables you to integrate content engines into your network infrastructure.

Cisco IOS Release 12.1 and later releases allow the use of either WCCP Version 1 (WCCPv1) or Version 2 (WCCPv2).

The tasks in this document assume that you have already configured content engines on your network. For specific information on hardware and network planning associated with Cisco Content Engines and WCCP, see the Cisco Content Engines documentation at the following URL:

<http://www.cisco.com/univercd/cc/td/doc/product/webscale/content/index.htm>

## Finding Feature Information

Your software release may not support all the features documented in this module. For the latest feature information and caveats, see the release notes for your platform and software release. To find information about the features documented in this module, and to see a list of the releases in which each feature is supported, see the “[Feature Information for WCCP](#)” section on page 29.

Use Cisco Feature Navigator to find information about platform support and Cisco software image support. To access Cisco Feature Navigator, go to <http://www.cisco.com/go/cfn>. An account on Cisco.com is not required.

## Contents

- [Prerequisites for WCCP, page 2](#)
- [Restrictions for WCCP, page 2](#)



---

**Americas Headquarters:**  
**Cisco Systems, Inc., 170 West Tasman Drive, San Jose, CA 95134-1706 USA**

- [Information About WCCP, page 4](#)
- [How to Configure WCCP, page 14](#)
- [Configuration Examples for WCCP, page 23](#)
- [Additional References, page 28](#)
- [Feature Information for WCCP, page 29](#)

## Prerequisites for WCCP

- To use WCCP, IP must be configured on the interface connected to the Internet and another interface must be connected to the content engine.
- The interface connected to the content engine must be a Fast Ethernet or Gigabit Ethernet interface.

## Restrictions for WCCP

### General

The following limitations apply to WCCPv1 and WCCPv2:

- WCCP works only with IPv4 networks.

### WCCPv1

The following limitations apply to WCCPv1:

- WCCPv1 supports the redirection of HTTP (TCP port 80) traffic only.
- WCCPv1 does not allow multiple routers to be attached to a cluster of content engines.

### WCCPv2

The following limitations apply to WCCPv2:

- WCCP works only with IPv4 networks.
- For routers servicing a multicast cluster, the Time To Live (TTL) value must be set at 15 or fewer.
- Service groups can comprise up to 32 content engines and 32 routers.
- All content engines in a cluster must be configured to communicate with all routers servicing the cluster.
- Multicast addresses must be from 224.0.0.0 to 239.255.255.255.

### WCCP VRF Support

In Cisco IOS Release 12.2(33)SRE, this feature is supported only on Cisco 7200 NPE-G2 and Cisco 7304-NPE-G100 routers.

### Layer 2 Forwarding and Return

The following limitations apply to WCCP Layer 2 Forwarding and Return:

- Layer 2 redirection requires that content engines be directly connected to an interface on each WCCP router. Unless multicast IP addresses are used, WCCP configuration of the content engine must reference the directly connected interface IP address of the WCCP router and not a loopback IP address or any other IP address configured on the WCCP router.

### Cisco ASR 1000 Series Aggregation Services Routers

- Cisco ASR 1000 series aggregation services routers do not support WCCPv1.
- Transiting packets are lost in the event of a forwarding processor (FP) failover on a 6-rack-unit (6RU) and 13RU chassis.
- All content engines in a cluster must be configured to communicate with all routers servicing the cluster.
- Hash assignment as a load-balancing method for a WCCP service is not supported. As of Cisco IOS XE Release 3.1S, clients which send HASH assignment will not be allowed to come online by the router. On a Cisco ASR 1000 router, the **show ip wccp 61 detail** command displays that Hash is an incompatible assignment method.
- The **show ip wccp** command displays information about software-based (process, fast and Cisco Express Forwarding [CEF]) forwarding of WCCP packets. The Cisco ASR 1000 implement WCCP in hardware, rather than in the CEF or process-switching paths. This results in a packet count of 0 when the **show ip wccp** command is entered. Use the **show platform software wccp interface counters** or **show platform software wccp counters** commands to display global statistics related to WCCP on the Cisco ASR 1000.

In Cisco IOS-XE Release 3.1S, the **show ip wccp** command displays redirected WCCP packets.

- WCCP packet redirection on outbound interfaces is not supported in XE releases prior to XE Release 3.1S

### Cisco Catalyst 4500 Series Switches

The following limitations apply to Cisco Catalyst 4500 series switches:

- Catalyst 4500 series switches do not support WCCPv1.
- Up to eight service groups are supported at the same time on the same client interface.
- The Layer 2 (L2) rewrite forwarding method is supported, but generic route encapsulation (GRE) is not.
- Direct Layer 2 (L2) connectivity to content engines is required; Layer 3 (L3) connectivity of one or more hops away is not supported.
- Ternary content addressable memory (TCAM) friendly mask-based assignment is supported, but the hash bucket-based method is not.
- Redirect access control list (ACL) for WCCP on a client interface is not supported.
- Incoming traffic redirection on an interface is supported, but outgoing traffic redirection is not.
- When TCAM space is exhausted, traffic is not redirected; it is forwarded normally.
- WCCP version 2 standard allows for support of up to 256 distinct masks. However, a Catalyst 4500 series switch only supports mask assignment table with a single mask.

### Cisco Catalyst 6500 Series Switches

The following limitation apply to Cisco Catalyst 6500 series switches:

- With a Policy Feature Card 2 (PFC2), Release 12.2(17d)SXB and later releases support WCCP.
- With a PFC3, Release 12.2(18)SXD1 and later releases support WCCP.
- To use the WCCP Layer 2 PFC redirection feature, configure WCCP on the Catalyst 6500 series switch as described in this chapter and configure accelerated WCCP on the cache engine as described in the [Transparent Caching](#) document available at the following URL:

[http://www.cisco.com/en/US/docs/app\\_ntwk\\_services/waas/acns/v42/configuration/guide/transprt.html](http://www.cisco.com/en/US/docs/app_ntwk_services/waas/acns/v42/configuration/guide/transprt.html)

- Cisco Application and Content Networking System (ACNS) software releases later than Release 4.2.2 support WCCP Layer 2 Policy Feature Card (PFC) redirection hardware acceleration.
- A content engine configured for mask assignment that tries to join a farm where the selected assignment method is hash remains out of the farm as long as the cache engine assignment method does not match that of the existing farm.
- With WCCP Layer 2 PFC redirection as the forwarding method for a service group, the packet counters in the **show ip wccp service-number** command output display flow counts instead of packet counts.

### Catalyst 6500 Series Switches and Cisco 7600 Series Routers Access Control Lists

When WCCP is using the mask assignment, any redirect list is merged with the mask information from the appliance and the resulting merged access control list (ACL) is passed down to the Catalyst 6500 series switch or Cisco 7600 series router hardware.

The following restrictions apply to the redirect-list ACL:

- The ACL must be an IPV4 simple or extended ACL.
- The protocol must be IP, UDP, or TCP.
- Only individual source or destination port numbers may be specified; port ranges cannot be specified.
- The only valid matching criteria in addition to individual source or destination port numbers are **dscp** or **tos**.
- The use of **fragments**, **time-range**, **options** or any TCP flags is not permitted.

If the redirect ACL does not meet the above restrictions, the system will log the following error message:

```
WCCP-3-BADACE: Service <service group>, invalid access-list entry (seq:<sequence>,
reason:<reason>)
```

WCCP continues to redirect packets, but the redirection is carried out in software (NetFlow Switching) until the access list is adjusted.

## Information About WCCP

- [Understanding WCCP, page 5](#)
- [Layer 2 Forwarding, Redirection, and Return, page 5](#)
- [WCCP Mask Assignment, page 6](#)
- [Hardware Acceleration, page 6](#)
- [WCCPv1 Configuration, page 7](#)
- [WCCPv2 Configuration, page 8](#)
- [WCCP VRF Support, page 10](#)
- [WCCP Bypass Packets, page 11](#)
- [WCCP Closed Services and Open Services, page 11](#)
- [WCCP Outbound ACL Check, page 11](#)

- [WCCP Service Groups, page 12](#)
- [WCCP: Check Services All, page 13](#)

## Understanding WCCP

WCCP uses Cisco Content Engines (or other content engines running WCCP) to localize web traffic patterns in the network, enabling content requests to be fulfilled locally. Traffic localization reduces transmission costs and download time.

WCCP enables Cisco IOS routing platforms to transparently redirect content requests. The main benefit of transparent redirection is that users do not need to configure their browsers to use a web proxy. Instead, they can use the target URL to request content, and have their requests automatically redirected to a content engine. The word “transparent” in this case means that the end user does not know that a requested file (such as a web page) came from the content engine instead of from the originally specified server.

When a content engine receives a request, it attempts to service it from its own local cache. If the requested information is not present, the content engine issues its own request to the originally targeted server to get the required information. When the content engine retrieves the requested information, it forwards it to the requesting client and caches it to fulfill future requests, thus maximizing download performance and substantially reducing transmission costs.

WCCP enables a series of content engines, called a content engine cluster, to provide content to a router or multiple routers. Network administrators can easily scale their content engines to manage heavy traffic loads through these clustering capabilities. Cisco clustering technology enables each cluster member to work in parallel, resulting in linear scalability. Clustering content engines greatly improves the scalability, redundancy, and availability of your caching solution. You can cluster up to 32 content engines to scale to your desired capacity.

## Layer 2 Forwarding, Redirection, and Return

WCCP uses either Generic Routing Encapsulation (GRE) or Layer 2 (L2) to redirect or return IP traffic. When WCCP forwards traffic via GRE, the redirected packets are encapsulated within a GRE header. The packets also have a WCCP redirect header. When WCCP forwards traffic using L2, the original MAC header of the IP packet is overwritten and replaced with the MAC header for the WCCP client.

Using L2 as a forwarding method allows direct forwarding to the content engine without further lookup. Layer 2 redirection requires that the router and content engines are directly connected, that is, on the same IP subnetwork.

When WCCP returns traffic via GRE, the returned packets are encapsulated within a GRE header. The destination IP address is the address of the router and the source address is the address of the WCCP client. When WCCP returns traffic via L2, the original IP packet is returned without any added header information. The router to which the packet is returned will recognize the source of the packet and prevent redirection.

The WCCP redirection method does not have to match the return method.

L2 forwarding, return, or redirection are typically used for hardware accelerated platforms. In Cisco IOS Release 12.4(20)T and later releases, L2 forwarding, return, and redirection can also be used for software switching platforms.

On Cisco ASR 1000 series aggregation services routers, both the GRE and L2 forward/return methods use the hardware, so there is not any significant performance degradation between them.

For content engines running Application and Content Networking System (ACNS) software, use the **wccp custom-web-cache** command with the **l2-redirect** keyword to configure L2 redirection. For content engines running Cisco Wide Area Application Services (WAAS) software, use the **wccp tcp-promiscuous** command with the **l2-redirect** keyword to configure L2 redirection.

For more information on Cisco ACNS commands used to configure Cisco Content Engines, see the *Cisco ACNS Software Command Reference*, Release 5.5.13, at the following URL:

[http://www.cisco.com/en/US/docs/app\\_ntwk\\_services/waas/acns/v55\\_13/command/reference/5513cref.html](http://www.cisco.com/en/US/docs/app_ntwk_services/waas/acns/v55_13/command/reference/5513cref.html)

For more information on WAAS commands used to configure Cisco Content Engines, see the *Cisco Wide Area Application Services Command Reference (Software Versions 4.2.1)* at the following URL:

[http://www.cisco.com/en/US/docs/app\\_ntwk\\_services/waas/waas/v421/command/reference/cmdref.html](http://www.cisco.com/en/US/docs/app_ntwk_services/waas/waas/v421/command/reference/cmdref.html)

## WCCP Mask Assignment

The WCCP Mask Assignment feature enables mask assignment as the load-balancing method (instead of the default hash assignment method) for a WCCP service.

For content engines running Application and Content Networking System (ACNS) software, use the **wccp custom-web-cache** command with the **mask-assign** keywords to configure mask assignment. For content engines running Cisco Wide Area Application Services (WAAS) software, use the **wccp tcp-promiscuous** command with the **mask-assign** keyword to configure mask assignment.

For more information on Cisco ACNS commands used to configure Cisco Content Engines, see the *Cisco ACNS Software Command Reference*, Release 5.5.13, at the following URL:

[http://www.cisco.com/en/US/docs/app\\_ntwk\\_services/waas/acns/v55\\_13/command/reference/5513cref.html](http://www.cisco.com/en/US/docs/app_ntwk_services/waas/acns/v55_13/command/reference/5513cref.html)

For more information on WAAS commands used to configure Cisco Content Engines, see the *Cisco Wide Area Application Services Command Reference (Software Versions 4.2.1)* at the following URL:

[http://www.cisco.com/en/US/docs/app\\_ntwk\\_services/waas/waas/v421/command/reference/cmdref.html](http://www.cisco.com/en/US/docs/app_ntwk_services/waas/waas/v421/command/reference/cmdref.html)

## Hardware Acceleration

Catalyst 4500 series switches provide hardware acceleration for directly connected Cisco Content Engines.

Catalyst 6500 series switches and Cisco 7600 series routers provide WCCP Layer 2 Policy Feature Card (PFC) redirection hardware acceleration. Hardware acceleration allows Cisco Content Engines to perform a L2 MAC address rewrite redirection method when directly connected to a compatible switch or router.

Redirection processing is accelerated in the switching or routing hardware, which is more efficient than L3 redirection with Generic Routing Encapsulation (GRE). L2 redirection takes place on the switch or router, and is not visible to the Multilayer Switch Feature Card (MSFC). The WCCP L2 PFC redirection feature requires no configuration on the MSFC. The **show ip wccp {service-number | web-cache} detail** command displays which redirection method is in use for each content engine.

In order for the router or switch to make complete use of hardware redirection, the content engine must be configured with L2 redirection and mask assignment as discussed in the “[Layer 2 Forwarding, Redirection, and Return](#)” section on page 5.

Use the **ip wccp web-cache accelerated** command on hardware-based platforms to enforce the use of L2 redirection and mask assignment. Using this command configures the router to form a service group and redirect packets with an appliance only if the appliance is configured for L2 and mask assignment.

The following guidelines apply to WCCP Layer 2 PFC redirection:

- The WCCP Layer 2 PFC redirection feature sets the IP flow mask to full-flow mode.
- You can configure the Cisco Cache Engine software Release 2.2 or later releases to use the WCCP Layer 2 PFC redirection feature.
- L2 redirection takes place on the PFC and is not visible to the MSFC. The **show ip wccp {service-number | web-cache} detail** command on the MSFC displays statistics for only the first packet of a L2 redirected flow, which provides an indication of how many flows, rather than packets, are using L2 redirection. Entering the **show mls entries** command displays the other packets in the L2 redirected flows. The PFC3 provides hardware acceleration for GRE. If you use WCCP Layer 3 redirection with GRE, there is hardware support for encapsulation, but the PFC3 does not provide hardware support for decapsulation of WCCP GRE traffic.

#### Cisco ASR 1000 Series Aggregation Services Routers

WCCP implementation on the Cisco ASR 1000 series aggregation services routers is hardware accelerated by default. You do not need to configure the **ip wccp web-cache accelerated** command on Cisco ASR routers to enable hardware acceleration.

## WCCPv1 Configuration

With WCCPv1, only a single router services a cluster. In this scenario, this router is the device that performs all the IP packet redirection. [Figure 1](#) illustrates the WCCPv1 configuration.

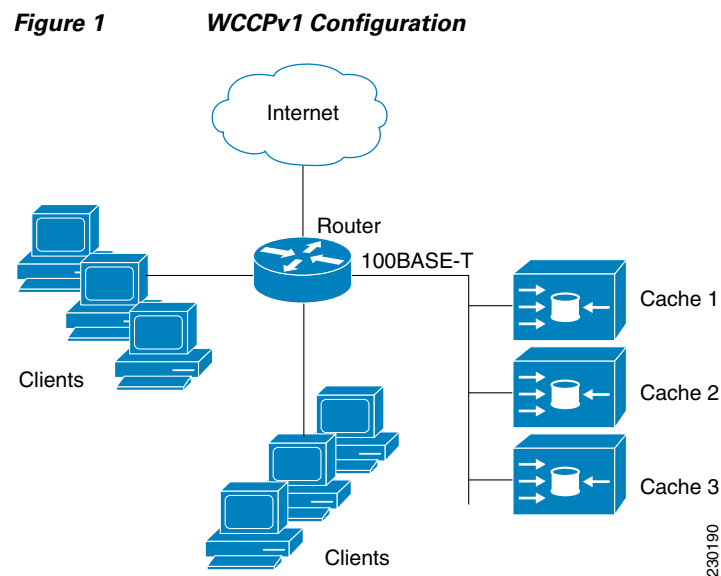

Content is not duplicated on the content engines. The benefit of using multiple content engines is that you can scale a caching solution by clustering multiple physical content engines to appear as one logical cache.

The following sequence of events details how WCCPv1 configuration works:

1. Each content engine is configured by the system administrator with the IP address of the control router. Up to 32 content engines can connect to a single control router.
2. The content engines send their IP addresses to the control router using WCCP, indicating their presence. Routers and content engines communicate to each other via a control channel; this channel is based on UDP port 2048.
3. This information is used by the control router to create a cluster view (a list of caches in the cluster). This view is sent to each content engine in the cluster, essentially making all the content engines aware of each other. A stable view is established after the membership of the cluster remains the same for a certain amount of time.
4. When a stable view has been established, one content engine is elected as the lead content engine. (The lead is defined as the content engine seen by all the content engines in the cluster with the lowest IP address). This lead content engine uses WCCP to indicate to the control router how IP packet redirection should be performed. Specifically, the lead content engine designates how redirected traffic should be distributed across the content engines in the cluster.

## WCCPv2 Configuration

Multiple routers can use WCCPv2 to service a content engine cluster. This configuration is in contrast to WCCPv1, in which only one router could redirect content requests to a cluster. [Figure 2](#) illustrates a sample configuration using multiple routers.

**Figure 2 Cisco Cache Engine Network Configuration Using WCCPv2**

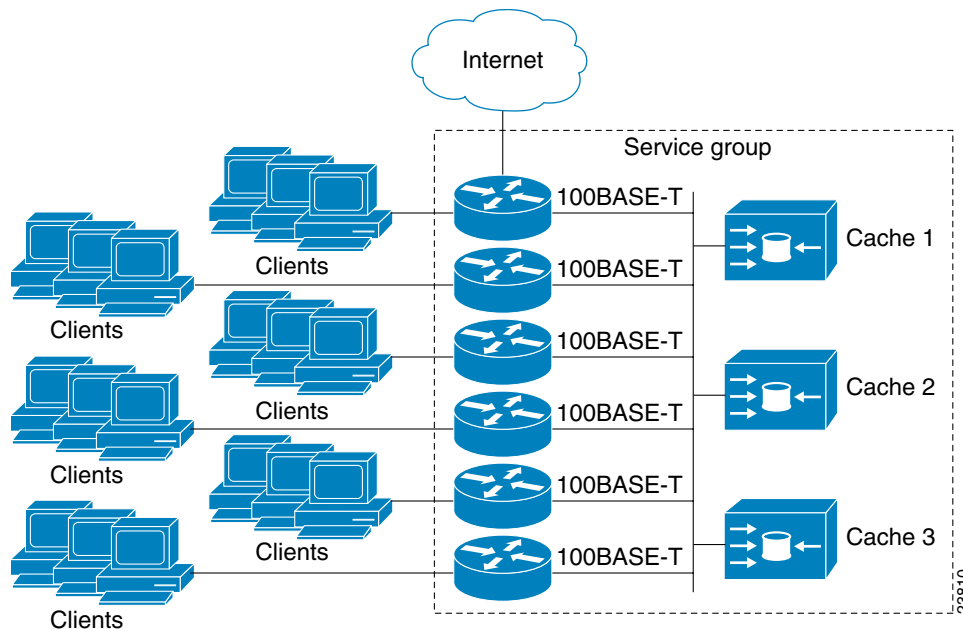

The subset of content engines within a cluster and routers connected to the cluster that are running the same service is known as a *service group*. Available services include TCP and User Datagram Protocol (UDP) redirection.

Using WCCPv1, the content engines were configured with the address of the single router. WCCPv2 requires that each content engine be aware of all the routers in the service group. To specify the addresses of all the routers in a service group, you must choose one of the following methods:

- **Unicast**—A list of router addresses for each of the routers in the group is configured on each content engine. In this case the address of each router in the group must be explicitly specified for each content engine during configuration.
- **Multicast**—A single multicast address is configured on each content engine. In the multicast address method, the content engine sends a single-address notification that provides coverage for all routers in the service group. For example, a content engine could indicate that packets should be sent to a multicast address of 224.0.0.100, which would send a multicast packet to all routers in the service group configured for group listening using WCCP (see the **ip wccp group-listen** interface configuration command for details).

The multicast option is easier to configure because you need only specify a single address on each content engine. This option also allows you to add and remove routers from a service group dynamically, without needing to reconfigure the content engines with a different list of addresses each time.

The following sequence of events details how WCCPv2 configuration works:

1. Each content engine is configured with a list of routers.
2. Each content engine announces its presence and a list of all routers with which it has established communications. The routers reply with their view (list) of content engines in the group.
3. When the view is consistent across all content engines in the cluster, one content engine is designated as the lead and sets the policy that the routers need to deploy in redirecting packets.

### Support for Services Other Than HTTP

WCCPv2 allows redirection of traffic other than HTTP (TCP port 80 traffic), including a variety of UDP and TCP traffic. WCCPv1 supported the redirection of HTTP (TCP port 80) traffic only. WCCPv2 supports the redirection of packets intended for other ports, including those used for proxy-web cache handling, File Transfer Protocol (FTP) caching, FTP proxy handling, web caching for ports other than 80, and Real Audio, video, and telephony applications.

To accommodate the various types of services available, WCCPv2 introduces the concept of multiple *service groups*. Service information is specified in the WCCP configuration commands using dynamic services identification numbers (such as 98) or a predefined service keyword (such as **web-cache**). This information is used to validate that service group members are all using or providing the same service.

The content engines in a service group specify traffic to be redirected by protocol (TCP or UDP) and up to eight source or destination ports. Each service group has a priority status assigned to it. The priority of a dynamic service is assigned by the content engine. The priority value is in the range of 0 to 255 where 0 is the lowest priority. The predefined web-cache service has an assigned priority of 240.

### Support for Multiple Routers

WCCPv2 allows multiple routers to be attached to a cluster of cache engines. The use of multiple routers in a service group allows for redundancy, interface aggregation, and distribution of the redirection load. WCCPv2 supports up to 32 routers per service group. Each service group is established and maintained independently.

### MD5 Security

WCCPv2 provides optional authentication that enables you to control which routers and content engines become part of the service group using passwords and the HMAC MD5 standard. Shared-secret MD5 one-time authentication (set using the `ip wccp [password [0 | 7] password]` global configuration command) enables messages to be protected against interception, inspection, and replay.

### Web Cache Packet Return

If a content engine is unable to provide a requested object it has cached due to error or overload, the content engine will return the request to the router for onward transmission to the originally specified destination server. WCCPv2 provides a check on packets that determines which requests have been returned from the content engine unserved. Using this information, the router can then forward the request to the originally targeted server (rather than attempting to resend the request to the content engine cluster). This process provides error handling transparency to clients.

Typical reasons why a content engine would reject packets and initiate the packet return feature include the following:

- Instances when the content engine is overloaded and has no room to service the packets
- Instances when the content engine is filtering for certain conditions that make caching packets counterproductive (for example, when IP authentication has been turned on)

### Load Distribution

WCCPv2 can be used to adjust the load being offered to individual content engines to provide an effective use of the available resources while helping to ensure high quality of service (QoS) to the clients. WCCPv2 allows the designated content engine to adjust the load on a particular content engine and balance the load across the content engines in a cluster. WCCPv2 uses three techniques to perform load distribution:

- **Hot Spot Handling**—Allows an individual hash bucket to be distributed across all the content engines. Prior to WCCPv2, information from one hash bucket could only go to one content engine.
- **Load Balancing**—Allows the set of hash buckets assigned to a content engine to be adjusted so that the load can be shifted from an overwhelmed content engine to other members that have available capacity.
- **Load Shedding**—Enables the router to selectively redirect the load to avoid exceeding the capacity of a content engine.

The use of these hashing parameters prevents one content engine from being overloaded and reduces the potential for bottlenecking.

## WCCP VRF Support

The WCCP VRF Support feature enhances the existing WCCPv2 protocol by implementing support for virtual routing and forwarding (VRF).

The WCCP VRF Support feature allows service groups to be configured on a per VRF basis in addition to those defined globally.

Along with the service identifier, the VRF of WCCP protocol packets arriving at the router is used to associate cache-engines with a configured service group.

The interface on which redirection is applied, the interface which is connected to cache engine, and the interface on which the packet would have left if it had not been redirected must be in the same VRF.

In Cisco IOS Release 12.2(33)SRE, this feature is supported only on Cisco 7200 NPE-G2 and Cisco 7304-NPE-G100 routers.

## WCCP Bypass Packets

WCCP intercepts IP packets and redirects those packets to a destination other than the destination that is specified in the IP header. Typically the packets are redirected from a web server on the Internet to a web cache that is local to the destination.

Occasionally a web cache cannot manage the redirected packets appropriately and returns the packets unchanged to the originating router. These packets are called bypass packets and are returned to the originating router using either Layer 2 forwarding without encapsulation (L2) or encapsulated in generic routing encapsulation (GRE). The router decapsulates and forwards the packets normally. The VRF associated with the ingress interface (or the global table if there is no VRF associated) is used to route the packet to the destination.

GRE is a tunneling protocol developed by Cisco that encapsulates packet types from a variety of protocols inside IP tunnels, creating a virtual point-to-point link over an IP network.

## WCCP Closed Services and Open Services

In applications where packet flows are intercepted and redirected by a Cisco IOS router to external WCCP client devices, it may be necessary to block the packet flows for the application when a WCCP client device is not available. This blocking is achieved by configuring a WCCP closed service. When a WCCP service is configured as closed, WCCP discards packets that do not have a WCCP client registered to receive the redirected traffic.

By default, WCCP operates as an open service, wherein communication between clients and servers proceeds normally in the absence of an intermediary device.

The **ip wccp service-list** command can only be used for closed-mode services. Use the **service-list** keyword and *service-access-list* argument to register an application protocol type or port number.

When there is a mismatch between the service-list ACL and the definition received from a cache engine, the service is not allowed to start.

## WCCP Outbound ACL Check

WCCP operates by intercepting IP packets and redirecting those packets to a destination other than the destination that is specified in the IP header. Typically the packets are redirected from a web server on the Internet to a web cache that is local to the redirecting router.

Access control lists (ACLs) filter network traffic by controlling whether routed packets are forwarded or blocked at the router interface. Each packet is examined to determine whether it will be forwarded or dropped, according to the specified criteria within the ACL. ACL criteria can be the source address of the traffic, the destination address of the traffic, or the upper-layer protocol. An IP ACL is a sequential collection of permit and deny conditions that apply to an IP address. The router tests addresses against the conditions in the ACL one at a time. The first match determines whether the address is accepted or rejected. Because Cisco IOS software stops testing conditions after the first match, the order of the conditions is critical. If no conditions match, the router rejects the address, by virtue of an implicit “deny all” clause.

If there is an outbound ACL configured on the interface at which redirection takes place, it is possible, under some circumstances, that hosts whose traffic is redirected will gain access to destinations to which they would otherwise be blocked.

The WCCP Outbound ACL Check feature ensures that the outbound ACL checking is performed at the original interface so that the checking is secure and consistent across all platforms and Cisco IOS switching paths.

## WCCP Service Groups

WCCP is a component of Cisco IOS software that redirects traffic with defined characteristics from its original destination to an alternative destination. The typical application of WCCP is to redirect traffic bound for a remote web server to a local web cache to improve response time and optimize network resource usage.

The nature of the selected traffic for redirection is defined by service groups specified on content engines and communicated to routers by using WCCP. The current implementation of WCCP in Cisco IOS releases prior to Cisco IOS Release 12.3(14)T allowed a maximum of eight service groups to be defined. This maximum restricted caching deployments. In Cisco IOS Release 12.3(14)T and later releases, the maximum number of service groups allowed across all VRFs is increased to 256.

WCCPv2 supports up to 32 routers per service group. Each service group is established and maintained independently.

WCCPv2 uses service groups based on logical redirection services, deployed for intercepting and redirecting traffic. The standard service is web cache, which intercepts TCP port 80 (HTTP) traffic and redirects that traffic to the content engines. This service is referred to as a *well-known service*, because the characteristics of the web cache service are known by both the router and content engines. A description of a well-known service is not required beyond a service identification. To specify the standard web cache service, use the **ip wccp** command with the **web-cache** keyword.



### Note

---

More than one service can run on a router at the same time, and routers and content engines can be part of multiple service groups at the same time.

---

**Figure 3** WCCP Service Groups

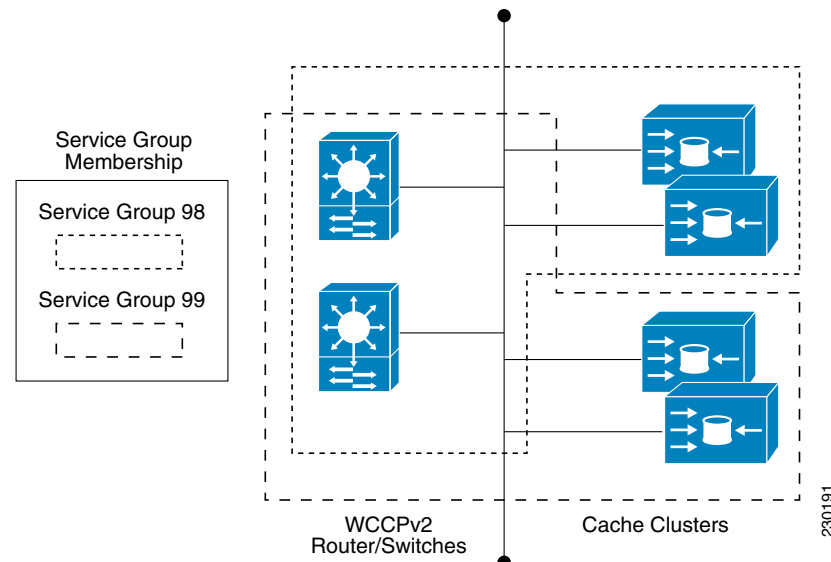

The dynamic services are defined by the content engines; the content engine instructs the router which protocol or ports to intercept, and how to distribute the traffic. The router itself does not have information on the characteristics of the dynamic service group's traffic, because this information is provided by the first content engine to join the group. In a dynamic service, up to eight ports can be specified within a single protocol.

Cisco Content Engines, for example, use dynamic service 99 to specify a reverse-proxy service. However, other content engine devices may use this service number for some other service. The configuration information in this document describes how to enable general services on Cisco routers.

## WCCP: Check Services All

An interface may be configured with more than one WCCP service. When more than one WCCP service is configured on an interface, the precedence of a service depends on the relative priority of the service compared to the priority of the other configured services. Each WCCP service has a priority value as part of its definition. When an interface is configured with more than one WCCP service, the precedence of the packets is matched against service groups in priority order.



### Note

The priority of a WCCP service group cannot be configured via Cisco IOS software.

With the **ip wccp check services all** command, WCCP can be configured to check all configured services for a match and perform redirection for those services if appropriate. The caches to which packets are redirected can be controlled by a redirect ACL as well as by the service priority.

If no WCCP services are configured with a redirect ACL, the services are considered in priority order until a service is found that matches the IP packet. If no services match the packet, the packet is not redirected. If a service matches the packet and the service has a redirect ACL configured, then the IP packet will be checked against the ACL. If the packet is rejected by the ACL, the packet will not be passed down to lower priority services unless the **ip wccp check services all** command is configured. When the **ip wccp check services all** command is configured, WCCP will continue to attempt to match the packet against any remaining lower priority services configured on the interface.

# How to Configure WCCP

The following configuration tasks assume that you have already installed and configured the content engines you want to include in your network. You must configure the content engines in the cluster before configuring WCCP functionality on your routers or switches. Refer to the *Cisco Cache Engine User Guide* for content engine configuration and setup tasks.

- [Configuring WCCP, page 14](#) (required)
- [Configuring Closed Services, page 16](#) (optional)
- [Registering a Router to a Multicast Address, page 17](#) (optional)
- [Using Access Lists for a WCCP Service Group, page 18](#) (optional)
- [Enabling the WCCP Outbound ACL Check, page 20](#) (optional)
- [Verifying and Monitoring WCCP Configuration Settings, page 21](#) (optional)

## Configuring WCCP

Perform this task to configure WCCP.

Until you configure a WCCP service using the **ip wccp {web-cache | service-number}** global configuration command, WCCP is disabled on the router. The first use of a form of the **ip wccp** command enables WCCP. By default WCCPv2 is used for services, but you can use WCCPv1 functionality instead. To change the running version of WCCP from Version 2 to Version 1, or to return to WCCPv2 after an initial change, use the **ip wccp version** command in global configuration mode.

If a function is not allowed in WCCPv1, an error prompt will be printed to the screen. For example, if WCCPv1 is running on the router and you try to configure a dynamic service, the following message will be displayed: “WCCP V1 only supports the web-cache service.” The **show ip wccp EXEC** command will display the WCCP protocol version number that is currently running on your router.

Using the **ip wccp web-cache password** command, you can set a password for a router and the content engines in a service group. MD5 password security requires that each router and content engine that wants to join a service group be configured with the service group password. The password can consist of up to eight characters. Each content engine or router in the service group will authenticate the security component in a received WCCP packet immediately after validating the WCCP message header. Packets failing authentication will be discarded.

### SUMMARY STEPS

1. **enable**
2. **configure terminal**
3. **ip wccp version {1 | 2}**
4. **ip wccp [vrf vrf-name] {web-cache | service-number} [group-address group-address] [redirect-list access-list] [group-list access-list] [password password]**
5. **interface type number**
6. **ip wccp [vrf vrf-name] {web-cache | service-number} redirect {out | in}**
7. **exit**
8. **interface type number**
9. **ip wccp redirect exclude in**

## DETAILED STEPS

	Command	Purpose
Step 1	<b>enable</b>  <b>Example:</b> Router> enable	Enables privileged EXEC mode. <ul style="list-style-type: none"> <li>Enter your password if prompted.</li> </ul>
Step 2	<b>configure terminal</b>  <b>Example:</b> Router# configure terminal	Enters global configuration mode.
Step 3	<b>ip wccp version {1   2}</b>  <b>Example:</b> Router(config)# ip wccp version 2	Specifies which version of WCCP to configure on a router. WCCPv2 is the default running version.
Step 4	<b>ip wccp [vrf vrf-name] {web-cache   service-number} [group-address group-address] [redirect-list access-list] [group-list access-list] [password password [0   7]]</b>  <b>Example:</b> Router(config)# ip wccp web-cache password password1	Specifies a web-cache or dynamic service to enable on the router, specifies a VRF-name to associate with the service group, specifies the IP multicast address used by the service group, specifies any access lists to use, specifies whether to use MD5 authentication, and enables the WCCP service.
Step 5	<b>interface type number</b>  <b>Example:</b> Router(config)# interface ethernet0/0	Targets an interface number for which the web cache service will run, and enters interface configuration mode.
Step 6	<b>ip wccp [vrf vrf-name] {web-cache   service-number} redirect {out   in}</b>  <b>Example:</b> Router(config-if)# ip wccp web-cache redirect in	Enables packet redirection on an outbound or inbound interface using WCCP.  As indicated by the <b>out</b> and <b>in</b> keyword options, redirection can be specified for outbound interfaces or inbound interfaces.
Step 7	<b>exit</b>  <b>Example:</b> Router(config-if)# exit	Exits interface configuration mode.
Step 8	<b>interface type number</b>  <b>Example:</b> Router(config)# interface GigabitEthernet0/2/0	Targets an interface number on which to exclude traffic for redirection, and enters interface configuration mode.
Step 9	<b>ip wccp redirect exclude in</b>  <b>Example:</b> Router(config-if)# ip wccp redirect exclude in	(Optional) Excludes traffic on the specified interface from redirection.

# Configuring Closed Services

Perform this task to specify the number of service groups for WCCP, to configure a service group as a closed or open service, and to optionally specify a check of all services.

## SUMMARY STEPS

1. **enable**
2. **configure terminal**
3. **ip wccp [vrf vrf-name] service-number service-list service-access-list mode {open | closed}**  
or  
**ip wccp [vrf vrf-name] web-cache mode {open | closed}**
4. **ip wccp check services all**
5. **ip wccp [vrf vrf-name] {web-cache | service-number}**
6. **exit**

## DETAILED STEPS

	Command or Action	Purpose
Step 1	<b>enable</b>  <b>Example:</b> Router> enable	Enables privileged EXEC mode. <ul style="list-style-type: none"><li>Enter your password if prompted.</li></ul>
Step 2	<b>configure terminal</b>  <b>Example:</b> Router# configure terminal	Enters global configuration mode.
Step 3	<b>ip wccp [vrf vrf-name] service-number service-list service-access-list mode {open   closed}</b> or <b>ip wccp [vrf vrf-name] web-cache mode {open   closed}</b>  <b>Example:</b> Router(config)# ip wccp 90 service-list 120 mode closed or  <b>Example:</b> Router(config)# ip wccp web-cache mode closed	Configures a dynamic WCCP service as closed or open. or Configures a web-cache service as closed or open. <b>Note</b> When configuring the web-cache service as a closed service, you cannot specify a service access list.  <b>Note</b> When configuring a dynamic WCCP service as a closed service, you must specify a service access list.

	Command or Action	Purpose
Step 4	<pre>ip wccp check services all</pre> <p><b>Example:</b> Router(config)# ip wccp check services all</p>	<p>(Optional) Enables a check of all WCCP services.</p> <p>With the <b>ip wccp check services all</b> command, WCCP can be configured to check the other configured services for a match and perform redirection for those services if appropriate. The caches to which packets are redirected can be controlled by the redirect ACL and not just the service description.</p> <p><b>Note</b> The <b>ip wccp check services all</b> command is a global WCCP command that applies to all services and is not associated with a single service.</p>
Step 5	<pre>ip wccp [vrf vrf-name] {web-cache   service-number}</pre> <p><b>Example:</b> Router(config)# ip wccp 201</p>	<p>Specifies the WCCP service identifier. You can specify the standard web-cache service or a dynamic service number from 0 to 255.</p> <p>The maximum number of services that can be specified is 256.</p>
Step 6	<pre>exit</pre> <p><b>Example:</b> Router(config)# exit</p>	<p>Exits to privileged EXEC mode.</p>

## Registering a Router to a Multicast Address

If you decide to use the multicast address option for your service group, you must configure the router to listen for the multicast broadcasts on an interface.

For network configurations where redirected traffic needs to traverse an intervening router, the router being traversed must be configured to perform IP multicast routing. You must configure the following two components to enable traversal over an intervening router:

- Enable IP multicast routing using the **ip multicast-routing** global configuration command.
- Enable the interfaces to which the cache engines will connect to receive multicast transmissions using the **ip wccp group-listen** interface configuration command.

### SUMMARY STEPS

1. **enable**
2. **configure terminal**
3. **ip multicast-routing [vrf vrf-name] [distributed]**
4. **ip wccp [vrf vrf-name] {web-cache | service-number} group-address multicast-address**
5. **interface type number**
6. **ip pim {sparse-mode | sparse-dense-mode | dense-mode [proxy-register {list access-list | route-map map-name}]}**
7. **ip wccp [vrf vrf-name] {web-cache | service-number} group-listen**

## DETAILED STEPS

	Command	Purpose
Step 1	<b>enable</b>  <b>Example:</b> Router> enable	Enables privileged EXEC mode. <ul style="list-style-type: none"><li>Enter your password if prompted.</li></ul>
Step 2	<b>configure terminal</b>  <b>Example:</b> Router# configure terminal	Enters global configuration mode.
Step 3	<b>ip multicast-routing</b> [ <b>vrf</b> <i>vrf-name</i> ] [ <b>distributed</b> ]  <b>Example:</b> Router(config)# ip multicast-routing	Enables IP multicast routing.
Step 4	<b>ip wccp</b> [ <b>vrf</b> <i>vrf-name</i> ] { <b>web-cache</b>   <i>service-number</i> } <b>group-address</b> <i>multicast-address</i>  <b>Example:</b> Router(config)# ip wccp 99 group-address 239.1.1.1	Specifies the multicast address for the service group.
Step 5	<b>interface</b> <i>type number</i>  <b>Example:</b> Router(config)# interface ethernet0/0	Enables the interfaces to which the content engines will connect to receive multicast transmissions for which the web cache service will run, and enters interface configuration mode.
Step 6	<b>ip pim</b> { <b>sparse-mode</b>   <b>sparse-dense-mode</b>   <b>dense-mode</b> [ <b>proxy-register</b> { <b>list</b> <i>access-list</i>   <b>route-map</b> <i>map-name</i> }]}	(Optional) Enables Protocol Independent Multicast (PIM) on an interface.  <b>Note</b> To ensure correct operation of the <b>ip wccp group-listen</b> command on Catalyst 6500 series switches and Cisco 7600 series routers, you must enter the <b>ip pim</b> command in addition to the <b>ip wccp group-listen</b> command.
Step 7	<b>ip wccp</b> [ <b>vrf</b> <i>vrf-name</i> ] { <b>web-cache</b>   <i>service-number</i> } <b>group-listen</b>  <b>Example:</b> Router(config-if)# ip wccp 99 group-listen	Configures an interface to enable or disable the reception of IP multicast packets for WCCP.

## Using Access Lists for a WCCP Service Group

Perform this task to configure the router to use an access list to determine which traffic should be directed to which content engines.

## SUMMARY STEPS

1. **enable**
2. **configure terminal**

3. **access-list** *access-list-number* **remark** *remark*
4. **access-list** *access-list-number* **permit** {*source* [*source-wildcard*] | **any**} [**log**]
5. **access-list** *access-list-number* **remark** *remark*
6. **access-list** *access-list-number* **deny** {*source* [*source-wildcard*] | **any**} [**log**]
7. Repeat some combination of Steps 3 through 6 until you have specified the sources on which you want to base your access list.
8. **ip wccp web-cache group-list** *access-list*
9. **ip wccp web-cache redirect-list** *access-list*

## DETAILED STEPS

	Command	Purpose
Step 1	<b>enable</b>  <b>Example:</b> Router> enable	Enables privileged EXEC mode. <ul style="list-style-type: none"> <li>Enter your password if prompted.</li> </ul>
Step 2	<b>configure terminal</b>  <b>Example:</b> Router# configure terminal	Enters global configuration mode.
Step 3	<b>access-list</b> <i>access-list-number</i> <b>remark</b> <i>remark</i>  <b>Example:</b> Router(config)# access-list 1 remark Give access to user1	(Optional) Adds a user-friendly comment about an access list entry. <ul style="list-style-type: none"> <li>A remark of up to 100 characters can precede or follow an access list entry.</li> </ul>
Step 4	<b>access-list</b> <i>access-list-number</i> <b>permit</b> { <i>source</i> [ <i>source-wildcard</i> ]   <b>any</b> } [ <b>log</b> ]  <b>Example:</b> Router(config)# access-list 1 permit 172.16.5.22 0.0.0.0	Creates an access list that enables or disables traffic redirection to the cache engine.  Permits the specified source based on a source address and wildcard mask. <ul style="list-style-type: none"> <li>Every access list needs at least one permit statement; it does not need to be the first entry.</li> <li>Standard IP access lists are numbered 1 to 99 or 1300 to 1999.</li> <li>If the <i>source-wildcard</i> is omitted, a wildcard mask of 0.0.0.0 is assumed, meaning match on all bits of the source address.</li> <li>Optionally use the keyword <b>any</b> as a substitute for the <i>source source-wildcard</i> to specify the source and source wildcard of 0.0.0.0 255.255.255.255.</li> <li>In this example, host 172.16.5.22 is allowed to pass the access list.</li> </ul>

	Command	Purpose
Step 5	<p><b>access-list</b> <i>access-list-number</i> <b>remark</b> <i>remark</i></p> <p><b>Example:</b> Router(config)# access-list 1 remark Give access to user1</p>	<p>(Optional) Adds a user-friendly comment about an access list entry.</p> <ul style="list-style-type: none"> <li>A remark of up to 100 characters can precede or follow an access list entry.</li> </ul>
Step 6	<p><b>access-list</b> <i>access-list-number</i> <b>deny</b> [<i>source</i> [<i>source-wildcard</i>]   <b>any</b>] [<b>log</b>]</p> <p><b>Example:</b> Router(config)# access-list 1 deny 172.16.7.34 0.0.0.0</p>	<p>Denies the specified source based on a source address and wildcard mask.</p> <ul style="list-style-type: none"> <li>If the <i>source-wildcard</i> is omitted, a wildcard mask of 0.0.0.0 is assumed, meaning match on all bits of the source address.</li> <li>Optionally use the abbreviation <i>any</i> as a substitute for the <i>source source-wildcard</i> to specify the source and source wildcard of 0.0.0.0 255.255.255.255.</li> <li>In this example, host 172.16.7.34 is denied passing the access list.</li> </ul>
Step 7	Repeat some combination of Steps 3 through 6 until you have specified the sources on which you want to base your access list.	Remember that all sources not specifically permitted are denied by an implicit <b>deny</b> statement at the end of the access list.
Step 8	<p><b>ip wccp</b> [<i>vrf vrf-name</i>] <b>web-cache group-list</b> <i>access-list</i></p> <p><b>Example:</b> Router(config) ip wccp web-cache group-list 1</p>	Indicates to the router from which IP addresses of content engines to accept packets.
Step 9	<p><b>ip wccp</b> [<i>vrf vrf-name</i>] <b>web-cache redirect-list</b> <i>access-list</i></p> <p><b>Example:</b> Router(config)# ip wccp web-cache redirect-list 1</p>	(Optional) Disables caching for certain clients.

## Enabling the WCCP Outbound ACL Check



### Note

When all redirection is performed in the hardware, the mode of redirection will change when outbound ACL checking is enabled. The first packet is switched in software to allow the extra ACL check to be performed before a shortcut is installed.

### SUMMARY STEPS

- enable**
- configure terminal**
- ip wccp** [*vrf vrf-name*] { **web-cache** | *service-number* } [**group-address** *multicast-address*] [**redirect-list** *access-list*] [**group-list** *access-list*] [**password** *password*]
- ip wccp check acl outbound**

## 5. exit

## DETAILED STEPS

	Command or Action	Purpose
Step 1	<b>enable</b>  <b>Example:</b> Router> enable	Enables privileged EXEC mode. <ul style="list-style-type: none"><li>Enter your password if prompted.</li></ul>
Step 2	<b>configure terminal</b>  <b>Example:</b> Router# configure terminal	Enters global configuration mode.
Step 3	<b>ip wccp</b> [ <b>vrf</b> <i>vrf-name</i> ] [ <b>web-cache</b>   <i>service-number</i> ] [ <b>group-address</b> <i>multicast-address</i> ] [ <b>redirect-list</b> <i>access-list</i> ] [ <b>group-list</b> <i>access-list</i> ] [ <b>password</b> <i>password</i> ]  <b>Example:</b> Router(config)# ip wccp web-cache	Enables the support for a Cisco content engine service group or any content engine service group and configures a redirect ACL list or group ACL.  <b>Note</b> The <b>web-cache</b> keyword is for WCCP version 1 and version 2 and the <i>service-number</i> argument is for WCCP version 2 only.
Step 4	<b>ip wccp check acl outbound</b>  <b>Example:</b> Router(config)# ip wccp check acl outbound	Enables the ACL outbound check on the originating interface.
Step 5	<b>exit</b>  <b>Example:</b> Router(config)# exit	Exits global configuration.

## Verifying and Monitoring WCCP Configuration Settings

Use the following commands in EXEC mode to verify and monitor the configuration settings for WCCP.

## SUMMARY STEPS

- enable
- show ip wccp [**vrf** *vrf-name*] [*service-number* | **web-cache**] [**detail** | **view**]
- show ip interface
- more system:running-config

## DETAILED STEPS

	Command or Action	Purpose
Step 1	<p><b>enable</b></p> <p><b>Example:</b> Router&gt; enable</p>	<p>Enables privileged EXEC mode.</p> <ul style="list-style-type: none"> <li>Enter your password if prompted.</li> </ul>
Step 2	<p><b>show ip wccp</b> [<i>vrf vrf-name</i>] [<i>service-number</i>   <i>web-cache</i>] [<i>detail</i>   <i>view</i>]</p> <p><b>Example:</b> Router# show ip wccp 24 detail</p>	<p>Displays global information related to WCCP, including the protocol version currently running, the number of content engines in the router service group, which content engine group is allowed to connect to the router, and which access list is being used. The argument and keywords are as follows:</p> <ul style="list-style-type: none"> <li><i>service-number</i>—(Optional) Dynamic number of the web-cache service group being controlled by the content engine. The range is from 0 to 99. For web caches that use Cisco Content Engines, the reverse proxy service is indicated by a value of 99.</li> <li><b>web-cache</b>—(Optional) Statistics for the web-cache service.</li> <li><b>detail</b>—(Optional) Other members of a particular service group or web cache that have or have not been detected.</li> <li><b>view</b>—(Optional) Information about a router or all web caches.</li> </ul>
Step 3	<p><b>show ip interface</b></p> <p><b>Example:</b> Router# show ip interface</p>	<p>Displays status about whether any <b>ip wccp redirection</b> commands are configured on an interface. For example, “Web Cache Redirect is enabled / disabled.”</p>
Step 4	<p><b>more system:running-config</b></p> <p><b>Example:</b> Router# more system:running-config</p>	<p>(Optional) Displays contents of the currently running configuration file (equivalent to the <b>show running-config</b> command.)</p>

## Troubleshooting Tips

Problems have been encountered because CPU usage is very high when WCCP is enabled. The counters enable a determination of the bypass traffic directly on the router and can indicate whether or not this is the cause. In some situations, 10 percent bypass traffic may be normal; in other situations, it may be high. However, any figure above 25 percent should prompt a closer investigation of what is occurring in the web cache.

If the counters suggest that the level of bypass traffic is high, the next step is to examine the bypass counters in the content engine and determine why the content engine is choosing to bypass the traffic. You can log in to the content engine console and use CLI to investigate further. The counters allow you to determine the percent of traffic being bypassed.

## Configuration Examples for WCCP

- [Example: Changing the Version of WCCP on a Router, page 23](#)
- [Example: Configuring a General WCCPv2 Session, page 23](#)
- [Example: Setting a Password for a Router and Content Engines, page 24](#)
- [Example: Configuring a Web Cache Service, page 24](#)
- [Example: Running a Reverse Proxy Service, page 24](#)
- [Example: Registering a Router to a Multicast Address, page 24](#)
- [Example: Using Access Lists, page 25](#)
- [Example: WCCP Outbound ACL Check Configuration, page 25](#)
- [Example: Verifying WCCP Settings, page 25](#)

### Example: Changing the Version of WCCP on a Router

The following example shows how to change the WCCP version from the default of WCCPv2 to WCCPv1, and enabling the web-cache service in WCCPv1:

```
Router# show ip wccp

% WCCP version 2 is not enabled

Router# configure terminal
Router(config)# ip wccp version 1
Router(config)# end
Router# show ip wccp

% WCCP version 1 is not enabled
Router# configure terminal
Router(config)# ip wccp web-cache
Router(config)# end
Router# show ip wccp

Global WCCP information:
  Router information:
    Router Identifier:          10.4.9.8
    Protocol Version:          1.0
  .
  .
  .
```

### Example: Configuring a General WCCPv2 Session

The following example shows how to configure a general WCCPv2 session:

```
Router# configure terminal
ip wccp web-cache group-address 224.1.1.100 password password1
interface ethernet0
ip wccp web-cache redirect out
exit
ip wccp check services all ! Configures a check of all WCCP services.
```

## Example: Setting a Password for a Router and Content Engines

The following example shows how to configure a WCCPv2 password where the password is password1:

```
Router# configure terminal
Router(config)# ip wccp web-cache password password1
```

## Example: Configuring a Web Cache Service

```
Router# configure terminal
Router(config)# ip wccp web-cache
Router(config)# interface ethernet 0
Router(config-if)# ip wccp web-cache redirect out
Router(config-if)# exit
Router# copy running-config startup-config
```

The following example shows how to configure a session in which redirection of HTTP traffic arriving on Ethernet interface 0/1 is enabled:

```
Router# configure terminal
Router(config)# interface ethernet 0/1
Router(config-if)# ip wccp web-cache redirect in
Router(config-if)# exit
Router# show ip interface ethernet 0/1
.
.
.
WCCP Redirect inbound is enabled
WCCP Redirect exclude is disabled
.
.
.
```

## Example: Running a Reverse Proxy Service

The following example assumes that you are configuring a service group using Cisco cache engines, which use dynamic service 99 to run a reverse proxy service:

```
Router# configure terminal
Router(config)# ip wccp 99
Router(config)# interface ethernet 0
Router(config-if)# ip wccp 99 redirect out
```

## Example: Registering a Router to a Multicast Address

The following example shows how to register a router to a multicast address of 224.1.1.100:

```
Router(config)# ip wccp web-cache group-address 224.1.1.100
Router(config)# interface ethernet 0
Router(config-if)# ip wccp web cache group-listen
```

The following example shows a router configured to run a reverse proxy service, using the multicast address of 224.1.1.1. Redirection applies to packets outgoing via interface Ethernet interface 0:

```
Router(config)# ip wccp 99 group-address 224.1.1.1
Router(config)# interface ethernet 0
Router(config-if)# ip wccp 99 redirect out
```

## Example: Using Access Lists

To achieve better security, you can use a standard access list to notify the router which IP addresses are valid addresses for a content engine attempting to register with the current router. The following example shows a standard access list configuration session where the access list number is 10 for some sample hosts:

```
Router(config)# access-list 10 permit host 11.1.1.1
Router(config)# access-list 10 permit host 11.1.1.2
Router(config)# access-list 10 permit host 11.1.1.3
Router(config)# ip wccp web-cache group-list 10
```

To disable caching for certain clients, servers, or client/server pairs, you can use WCCP access lists. The following example shows that any requests coming from 10.1.1.1 to 12.1.1.1 will bypass the cache, and that all other requests will be serviced normally:

```
Router(config)# ip wccp web-cache redirect-list 120
Router(config)# access-list 120 deny tcp host 10.1.1.1 any
Router(config)# access-list 120 deny tcp any host 12.1.1.1
Router(config)# access-list 120 permit ip any any
```

The following example configures a router to redirect web-related packets received via interface ethernet 0/1, destined to any host except 209.165.200.224:

```
Router(config)# access-list 100 deny ip any host 209.165.200.224
Router(config)# access-list 100 permit ip any any
Router(config)# ip wccp web-cache redirect-list 100
Router(config)# interface Ethernet 0/1
Router(config-if)# ip wccp web-cache redirect in
```

## Example: WCCP Outbound ACL Check Configuration

The following configuration example shows that the access list prevents traffic from network 10.0.0.0 leaving Fast Ethernet interface 0/0. Because the outbound ACL check is enabled, WCCP does not redirect that traffic. WCCP checks packets against the ACL before they are redirected.

```
Router(config)# ip wccp web-cache
Router(config)# ip wccp check acl outbound
Router(config)# interface fastethernet0/0
Router(config-if)# ip access-group 10 out
Router(config-if)# exit
Router(config)# ip wccp web-cache redirect-list redirect-out
Router(config)# access-list 10 deny 10.0.0.0 0.255.255.255
Router(config)# access-list 10 permit any
```

If the outbound ACL check is disabled, the HTTP packets from network 10.0.0.0 would be redirected to a web cache. Users with that network address could retrieve web pages even though the network administrator wanted to prevent it.

## Example: Verifying WCCP Settings

The following example shows how to verify your configuration changes by using the **more system:running-config** command in privileged EXEC mode. The following example shows that both the web cache service and dynamic service 99 are enabled on the router:

```
Router# more system:running-config
```

```
Building configuration...
Current configuration:
!
version 12.0
service timestamps debug uptime
service timestamps log uptime
no service password-encryption
service udp-small-servers
service tcp-small-servers
!
hostname router4
!
enable secret 5 $1$nSVy$faliJsVQXVPW.KuCxZNT1
enable password password1
!
ip subnet-zero
ip wccp web-cache
ip wccp 99
ip domain-name cisco.com
ip name-server 10.1.1.1
ip name-server 10.1.1.2
ip name-server 10.1.1.3
!
!
!
interface Ethernet0
ip address 10.3.1.2 255.255.255.0
no ip directed-broadcast
ip wccp web-cache redirect out
ip wccp 99 redirect out
no ip route-cache
no ip mroute-cache
!

interface Ethernet1
ip address 10.4.1.1 255.255.255.0
no ip directed-broadcast
ip wccp 99 redirect out
no ip route-cache
no ip mroute-cache
!
interface Serial0
no ip address
no ip directed-broadcast
no ip route-cache
no ip mroute-cache
shutdown
!
interface Serial1
no ip address
no ip directed-broadcast
no ip route-cache
no ip mroute-cache
shutdown
!
ip default-gateway 10.3.1.1
ip classless
ip route 0.0.0.0 0.0.0.0 10.3.1.1
no ip http server
!
!
!
line con 0
transport input none
```

```
line aux 0
transport input all
line vty 0 4
password alaska1
login
!
end
```

The following example shows how to display information about bypassed packets for process, fast, and CEF that are switching paths in Cisco IOS.

```
Router# show ip wccp web-cache detail
```

```
WCCP Client information:
Web Client ID:      10.10.10.1
Protocol Version:   2.0
State:              Usable
Initial Hash Info:  0000000000000000000000000000000000000000
Assigned Hash Info: FFFFFFFFFFFFFFFFFFFFFFFFFFFFFFFFFF
                   FFFFFFFFFFFFFFFFFFFFFFFFFFFFFFFFFF
Hash Allotment:     256 (100.00%)
Packets Redirected: 4320
Connect Time:       00:04:53
Bypassed Packets
Process:            0
Fast:               0
CEF:                250
```

For more information about the **show ip wccp web-cache** command, see the [Cisco IOS IP Application Services Command Reference](#).

# Additional References

## Related Documents

Related Topic	Document Title
Cisco IOS commands	<a href="#">Cisco IOS Master Commands List, All Releases</a>
Cisco ACNS software configuration information	<ul style="list-style-type: none"> <li>• <a href="#">Cisco ACNS Software Caching Configuration Guide</a>, Release 4.2</li> <li>• <a href="#">Cisco ACNS Software</a> listing page on Cisco.com</li> </ul>
IP Access List overview, configuration tasks, and commands	<ul style="list-style-type: none"> <li>• <a href="#">IP Access List Features Roadmap</a></li> <li>• <a href="#">Cisco IOS Security Command Reference</a></li> </ul>
IP addressing and services commands and configuration tasks	<ul style="list-style-type: none"> <li>• <a href="#">Cisco IOS IP Addressing Services Configuration Guide</a></li> <li>• <a href="#">Cisco IOS IP Addressing Services Command Reference</a></li> </ul>
WCCP commands: complete command syntax, command mode, command history, defaults, usage guidelines, and examples	<a href="#">Cisco IOS IP Application Services Command Reference</a>

## Standards

Standard	Title
No new or modified standards are supported, and support for existing standards has not been modified.	—

## MIBs

MIB	MIBs Link
No new or modified MIBs are supported, and support for existing MIBs has not been modified.	To locate and download MIBs for selected platforms, Cisco software releases, and feature sets, use Cisco MIB Locator found at the following URL: <a href="http://www.cisco.com/go/mibs">http://www.cisco.com/go/mibs</a>

## RFCs

RFC	Title
No new or modified RFCs are supported, and support for existing RFCs has not been modified.	

## Technical Assistance

Description	Link
<p>The Cisco Support website provides extensive online resources, including documentation and tools for troubleshooting and resolving technical issues with Cisco products and technologies.</p> <p>To receive security and technical information about your products, you can subscribe to various services, such as the Product Alert Tool (accessed from Field Notices), the Cisco Technical Services Newsletter, and Really Simple Syndication (RSS) Feeds.</p> <p>Access to most tools on the Cisco Support website requires a Cisco.com user ID and password.</p>	<p><a href="http://www.cisco.com/cisco/web/support/index.html">http://www.cisco.com/cisco/web/support/index.html</a></p>

## Feature Information for WCCP

**Table 1** lists the features in this module and provides links to specific configuration information.

Use Cisco Feature Navigator to find information about platform support and software image support. Cisco Feature Navigator enables you to determine which software images support a specific software release, feature set, or platform. To access Cisco Feature Navigator, go to <http://www.cisco.com/go/cfn>. An account on Cisco.com is not required.



### Note

**Table 1** lists only the software release that introduced support for a given feature in a given software release train. Unless noted otherwise, subsequent releases of that software release train also support that feature.

Table 1 Feature Information for WCCP

Feature Name	Releases	Feature Information
WCCP Bypass Counters	12.3(7)T 12.2(25)S	<p>The WCCP Bypass Counters feature allows you to display a count of packets that have been bypassed by a web cache and returned to the originating router to be forwarded normally.</p> <p>The following sections provide information about this feature:</p> <ul style="list-style-type: none"> <li>• <a href="#">WCCP Bypass Packets, page 11</a></li> <li>• <a href="#">Example: Verifying WCCP Settings, page 25</a></li> </ul> <p>The <b>show ip wccp</b> command was modified by this feature.</p>
WCCP Closed Services	12.4(11)T	<p>The WCCP Closed Services feature permits WCCP services to be configured so that WCCP always intercepts traffic for such services but, if no WCCP client (such as a content engine) has registered to receive this traffic, packets are discarded.</p> <p>This behavior supports AONS (Application-Oriented Network Services) applications, which require traffic to be transparently intercepted using WCCP but do not want the packets to be forwarded to their destination if the WCCP client is unavailable to perform its processing. (This is contrary to the traditional use of WCCP to assist caches where the absence of a cache does not change the behavior as observed by the user.)</p> <p>The following sections provide information about this feature:</p> <ul style="list-style-type: none"> <li>• <a href="#">WCCP Closed Services and Open Services, page 11</a></li> <li>• <a href="#">Configuring Closed Services, page 16</a></li> <li>• <a href="#">Example: Configuring a General WCCPv2 Session, page 23</a></li> </ul> <p>The <b>ip wccp</b> command was modified by this feature.</p>
WCCP Increased Services	12.3(14)T 12.2(33)SRA 12.2(33)SXH	<p>The WCCP Increased Services feature increases the number of services supported by WCCP to a maximum of 256 across all VRFs.</p> <p>The following sections provide information about this feature:</p> <ul style="list-style-type: none"> <li>• <a href="#">WCCP Service Groups, page 12</a></li> <li>• <a href="#">Configuring Closed Services, page 16</a></li> <li>• <a href="#">Configuring WCCP, page 14</a></li> <li>• <a href="#">Example: Verifying WCCP Settings, page 25</a></li> </ul> <p>The following commands were modified by this feature:  <b>ip wccp, ip wccp check services all, ip wccp outbound-acl-check, show ip wccp.</b></p>

**Table 1**      **Feature Information for WCCP (continued)**

Feature Name	Releases	Feature Information
WCCP Layer 2 Redirection / Forwarding	12.4(20)T	<p>The WCCP Layer 2 Redirection/Forwarding feature allows directly connected Cisco content engines to use Layer 2 redirection, which is more efficient than Layer 3 redirection via GRE encapsulation. You can configure a directly connected Cache Engine to negotiate use of the WCCP Layer 2 Redirection/Forwarding feature. The WCCP Layer 2 Redirection/Forwarding feature requires no configuration on the router or switch.</p> <p>The following sections provide information about this feature:</p> <ul style="list-style-type: none"> <li>• <a href="#">Restrictions for WCCP, page 2</a></li> <li>• <a href="#">Layer 2 Forwarding, Redirection, and Return, page 5</a></li> <li>• <a href="#">Support for Services Other Than HTTP, page 9</a></li> </ul> <p>There are no new or modified commands associated with this feature.</p>
WCCP L2 Return	12.4(20)T	<p>The WCCP L2 Return feature allows content engines to return packets to WCCP routers directly connected at Layer 2 by swapping the source and destination MAC addresses rather than tunneling packets back to the router inside a Layer 3 GRE tunnel.</p> <p>The following sections provide information about this feature:</p> <ul style="list-style-type: none"> <li>• <a href="#">Layer 2 Forwarding, Redirection, and Return, page 5</a></li> </ul> <p>There are no new or modified commands associated with this feature.</p>
WCCP Mask Assignment	12.4(20)T	<p>The WCCP Mask Assignment feature introduces support for ACNS/WAAS devices using mask assignment as a cache engine assignment method.</p> <p>The following section provides information about this feature:</p> <ul style="list-style-type: none"> <li>• <a href="#">WCCP Mask Assignment, page 6</a></li> </ul> <p>There are no new or modified commands associated with this feature.</p>

Table 1 Feature Information for WCCP (continued)

Feature Name	Releases	Feature Information
WCCP Outbound ACL Check	12.3(7)T 12.2(25)S	<p>The WCCP Outbound ACL Check feature enables you to ensure that traffic redirected by WCCP at an input interface is subjected to the outbound ACL checks that may be configured on the output interface prior to redirection.</p> <p>This feature is supported by Web Cache Communication Protocol (WCCP) Version 1 and Version 2.</p> <p>The following sections provide information about this feature:</p> <ul style="list-style-type: none"> <li>• <a href="#">WCCP Outbound ACL Check, page 11</a></li> <li>• <a href="#">Enabling the WCCP Outbound ACL Check, page 20</a></li> <li>• <a href="#">Example: WCCP Outbound ACL Check Configuration, page 25</a></li> </ul> <p>The following commands were introduced or modified by this feature: <b>ip wccp, ip wccp check acl outbound</b></p>
WCCP Redirection on Inbound Interfaces	12.1(3)T 15.0(1)S	<p>The WCCP Redirection on Inbound Interfaces feature enables interfaces to be configured for input redirection for a particular WCCP service. When this feature is enabled on an interface, all packets arriving at that interface are compared against the specified WCCP service. If the packets match, they will be redirected.</p> <p>The following sections provide information about this feature:</p> <ul style="list-style-type: none"> <li>• <a href="#">Restrictions for WCCP, page 2</a></li> <li>• <a href="#">Configuring WCCP, page 14</a></li> <li>• <a href="#">Example: Configuring a Web Cache Service, page 24</a></li> </ul> <p>The following commands were introduced or modified by this feature: <b>ip wccp redirect-list</b></p>

Table 1 Feature Information for WCCP (continued)

Feature Name	Releases	Feature Information
WCCP Version 2	12.0(3)T 15.0(1)S	<p>The WCCP Version 2 feature provides several enhancements and features to the WCCP protocol, including:</p> <ul style="list-style-type: none"> <li>• The ability of multiple routers to service a content engine cluster.</li> <li>• Redirection of traffic other than HTTP (TCP port 80 traffic), including a variety of UDP and TCP traffic.</li> <li>• Optional authentication that enables you to control which routers and content engines become part of the service group using passwords and the HMAC MD5 standard.</li> <li>• A check on packets that determines which requests have been returned from the content engine unserved.</li> <li>• Load adjustments for individual content engines to provide an effective use of the available resources while helping to ensure high quality of service (QoS) to the clients.</li> </ul> <p>The following sections provide information about this feature:</p> <ul style="list-style-type: none"> <li>• <a href="#">Restrictions for WCCP, page 2</a></li> <li>• <a href="#">WCCPv2 Configuration, page 8</a></li> <li>• <a href="#">Support for Services Other Than HTTP, page 9</a></li> <li>• <a href="#">Example: Configuring a General WCCPv2 Session, page 23</a></li> </ul> <p>The following commands were introduced or modified by this feature: <b>clear ip wccp, ip wccp, ip wccp group-listen, ip wccp redirect, ip wccp redirect exclude in, ip wccp version, show ip wccp</b></p>
WCCP VRF Support	15.0(1)M, 12.2(33)SRE	<p>The WCCP VRF Support feature provides enhancements to the existing WCCPv2 protocol which support VRF awareness.</p> <p>In Cisco IOS Release 12.2(33)SRE, this feature is supported only on Cisco 7200 NPE-G2 and Cisco 7304-NPE-G100 routers.</p> <p>The following sections provide information about this feature:</p> <ul style="list-style-type: none"> <li>• <a href="#">WCCP VRF Support, page 10</a></li> <li>• <a href="#">Configuring WCCP, page 14</a></li> </ul> <p>The following commands were introduced or modified by this feature: <b>clear ip wccp, debug ip wccp, ip wccp, ip wccp group-listen, ip wccp redirect, show ip wccp</b></p>

Cisco and the Cisco Logo are trademarks of Cisco Systems, Inc. and/or its affiliates in the U.S. and other countries. A listing of Cisco's trademarks can be found at [www.cisco.com/go/trademarks](http://www.cisco.com/go/trademarks). Third party trademarks mentioned are the property of their respective owners. The use of the word partner does not imply a partnership relationship between Cisco and any other company. (1005R)

Any Internet Protocol (IP) addresses and phone numbers used in this document are not intended to be actual addresses and phone numbers. Any examples, command display output, network topology diagrams, and other figures included in the document are shown for illustrative purposes only. Any use of actual IP addresses or phone numbers in illustrative content is unintentional and coincidental.

© 2007–2010 Cisco Systems, Inc. All rights reserved.