



# Configuring NHRP

---

**First Released: April 3, 2007**

**Last Updated: May 2, 2008**

The Next Hop Resolution Protocol (NHRP) is an Address Resolution Protocol (ARP)-like protocol that dynamically maps a Non-Broadcast Multi-Access (NBMA) network. With NHRP, systems attached to an NBMA network can dynamically learn the NBMA (physical) address of the other systems that are part of that network, allowing these systems to directly communicate.

NHRP is a client and server protocol where the hub is the Next Hop Server (NHS) and the spokes are the Next Hop Clients (NHCs). The hub maintains an NHRP database of the public interface addresses of each spoke. Each spoke registers its real address when it boots and queries the NHRP database for real addresses of the destination spokes to build direct tunnels.

## Finding Feature Information in This Module

Your Cisco IOS software release may not support all of the features documented in this module. To reach links to specific feature documentation in this module and to see a list of the releases in which each feature is supported, use the “[Feature Information for Configuring NHRP](#)” section on page 38.

## Finding Support Information for Platforms and Cisco IOS and Catalyst OS Software Images

Use Cisco Feature Navigator to find information about platform support and Cisco IOS and Catalyst OS software image support. To access Cisco Feature Navigator, go to <http://www.cisco.com/go/cfn>. An account on Cisco.com is not required.

## Contents

- [Information About NHRP, page 2](#)
- [How to Configure NHRP, page 9](#)
- [Configuration Examples for NHRP, page 30](#)
- [Additional References, page 37](#)
- [Feature Information for Configuring NHRP, page 38](#)



---

**Americas Headquarters:**  
**Cisco Systems, Inc., 170 West Tasman Drive, San Jose, CA 95134-1706 USA**

© 2007 Cisco Systems, Inc. All rights reserved.

# Information About NHRP

To configure NHRP, you should understand the following concepts:

- [How NHRP and NBMA Networks Interact, page 2](#)
- [Dynamically Built Hub-and-Spoke Networks, page 3](#)
- [Dynamic Spoke-to-Spoke Tunnels, page 5](#)
- [Spoke Refresh Mechanism for Spoke-to-Spoke Tunnels, page 8](#)

## How NHRP and NBMA Networks Interact

Most WAN networks are a collection of point-to-point links. Virtual tunnel networks (for example Generic Routing Encapsulation (GRE) tunnels) are also a collection of point-to-point links. To effectively scale the connectivity of these point-to-point links, they are usually grouped into a single or multilayer hub-and-spoke network. Multipoint interfaces (for example, GRE tunnel interfaces) can be used to reduce the configuration on a hub router in such a network. This resulting network is a Non-Broadcast Multi-Access (NBMA) network.

Because there are multiple tunnel endpoints reachable through the single multipoint interface, there needs to be a mapping from the logical tunnel endpoint IP address to the physical tunnel endpoint IP address in order to forward packets out the multipoint GRE (mGRE) tunnel interfaces over this NBMA network. This mapping could be statically configured, but it is preferable if the mapping can be discovered or learned dynamically.

NHRP is an ARP-like protocol that alleviates these NBMA network problems. With NHRP, systems attached to an NBMA network dynamically learn the NBMA address of the other systems that are part of that network, allowing these systems to directly communicate without requiring traffic to use an intermediate hop.

Routers, access servers, and hosts can use NHRP to discover the addresses of other routers and hosts connected to an NBMA network. Partially meshed NBMA networks typically have multiple logical networks behind the NBMA network. In such configurations, packets traversing the NBMA network might have to make several hops over the NBMA network before arriving at the exit router (the router nearest the destination network). When NHRP is combined with IPsec, the NBMA network is basically a collection of point-to-point logical tunnel links over a physical IP network.

NHRP allows two functions to help support these NBMA networks:

1. **NHRP Registration.** NHRP allows Next Hop Clients (NHCs) to dynamically register with Next Hop Servers (NHSs). This registration function allows the NHCs to join the NBMA network without configuration changes on the NHSs, especially in cases where the NHC has a dynamic physical IP address or is behind a Network Address Translation (NAT) router that dynamically changes the physical IP address. In these cases, it would be impossible to preconfigure the logical virtual private network (VPN IP) to physical (NBMA IP) mapping for the NHC on the NHS. See the [“NHRP Registration” section on page 4](#) for more information.
2. **NHRP Resolution.** NHRP allows one NHC (spoke) to dynamically discover the logical VPN IP to physical NBMA IP mapping for another NHC (spoke) within the same NBMA network. Without this discovery, IP packets traversing from hosts behind one spoke to hosts behind another spoke would have to traverse by way of the NHS (hub) router. This process would increase the utilization of the hub’s physical bandwidth and CPU to process these packets that enter and exit the hub on the multipoint interface. With NHRP, systems attached to an NBMA network dynamically learn the NBMA address of the other systems that are part of that network, allowing these systems to directly

communicate without requiring traffic to use an intermediate hop. This function alleviates the load on the intermediate hop (NHS) and can increase the overall bandwidth of the NBMA network to be greater than the bandwidth of the hub router.

## Dynamically Built Hub-and-Spoke Networks

With NHRP, the NBMA network is initially laid out as a hub-and-spoke network that can be multiple hierarchical layers of NHCs as spokes and NHSs as hubs. The NHCs are configured with static mapping information to reach their NHSs and will connect to their NHS and send an NHRP registration to the NHS. This configuration allows the NHS to dynamically learn the mapping information for the spoke, reducing the configuration needed on the hub and allowing the spoke to obtain a dynamic NBMA (physical) IP address.

Once the base hub-and-spoke network is dynamically built, NHRP resolution requests and responses can be used to dynamically discover spoke-to-spoke mapping information, which allows spokes to bypass the hub and contact each other directly. This process allows a dynamic mesh of connections between spokes to be built based on data traffic patterns without requiring a preconfigured static fully meshed network. Using a dynamic-mesh network allows smaller spoke routers to participate up to their capability in a large NBMA network when these smaller spoke routers do not have the resources to participate in a full mesh on the same size network. The smaller spoke routers do not need to build out all possible spoke-to-spoke links; these routers need to build only the ones they are currently using.

## Next Hop Server Selection

NHRP resolution requests traverse one or more hops (hubs) within the base hub-and-spoke NBMA subnetwork before reaching the station that is expected to generate a response. Each station (including the source station) chooses a neighboring NHS to which it forwards the request. The NHS selection procedure typically involves performing a routing decision based upon the network layer destination address of the NHRP request. The NHRP resolution request eventually arrives at a station that generates an NHRP resolution reply. This responding station either serves the destination, or is the destination itself. The responding station generates a reply using the source address from within the NHRP packet to determine where the reply should be sent.

The Cisco implementation of NHRP also supports and extends the IEEE RFC 2332, *NBMA Next Hop Resolution Protocol (NHRP)*.

The Cisco implementation of NHRP supports IP Version 4 at the network layer and at the link layer with multipoint GRE, Ethernet, Switched Multimegabit Data Service (SMDS), Frame Relay, and ATM. Although NHRP is available on Ethernet, NHRP need not be implemented over Ethernet media because Ethernet is capable of broadcasting and the standard Ethernet IP ARP protocol is sufficient.

**Figure 1** illustrates four routers connected to an NBMA network. Within the network are IP routers necessary for the routers to communicate with each other by tunneling the IP data packets in GRE IP tunnel packets. The infrastructure layer routers support logical IP tunnel circuit connections represented by hops 1, 2, and 3. When router A attempts to forward an IP packet from the source host to the destination host, NHRP is triggered. On behalf of the source host, router A sends an NHRP resolution request packet encapsulated in a GRE IP packet, which takes three hops across the network to reach router D, connected to the destination host. After router A receives a positive NHRP resolution reply, router A determines that router D is the NBMA IP next hop, and router A sends subsequent data IP packets for the destination to router D in one GRE IP tunnel hop.

**Figure 1** Next Hop Resolution Protocol

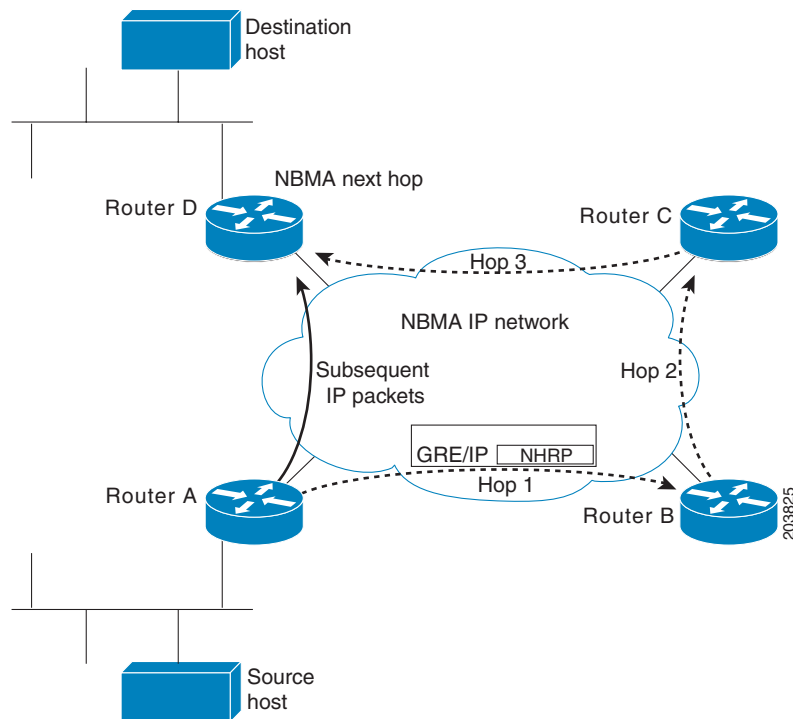

With NHRP, once the NBMA next hop is determined, the source either starts sending data packets to the destination (in a connectionless NBMA network such as GRE IP or SMDS) or establishes a virtual circuit (VC) connection to the destination. This connection is configured with the desired bandwidth and quality of service (QoS) characteristics for a connection-oriented NBMA network (such as Frame Relay or ATM) or with Dynamic Multipoint VPN (DMVPN) where an IPsec encryption peering must be established.

Other address resolution methods can be used while NHRP is deployed. IP hosts that rely upon the Logical IP Subnet (LIS) model might require ARP servers and services over the NBMA network, and deployed hosts might not implement NHRP, but might continue to support ARP variations. NHRP is designed to eliminate the suboptimal routing that results from the LIS model, and can be deployed with existing ARP services without interfering with them.

## NHRP Registration

NHRP registrations are sent from NHCs to their configured NHSs every one-third of the NHRP holdtime (configured by the `ip nhrp holdtime value` command), unless the `ip nhrp registration timeout value` command is configured, in which case registrations are sent out according to the configured timeout value. If an NHRP registration reply is not received for an NHRP registration request, the NHRP registration request is retransmitted at timeouts of 1, 2, 4, 8, 16, 32, and 64 seconds, then the sequence starts over again at 1.

The NHS is declared down if an NHRP registration reply is not received after three retransmission (7 seconds), and an NHRP resolution packets will no longer be sent to or by way of that NHS. NHRP registrations will continue to be sent at 1-, 2-, 4-, 8-, 16-, 32-, and 64-second intervals, probing the NHS until an NHRP registration reply is received. As soon as an NHRP registration reply is received the NHS is immediately declared up, the NHRP registration requests revert to being sent every one-third of NHRP

holdtime or the value configured in the **ip nhrp registration timeout** command, and the NHS can again be sent NHRP resolution requests. The **show ip nhrp nhs detail** command can be used to check the state of the NHRP NHSs.

## NHRP Used with a DMVPN

NHRP can be used to help build a VPN. In this context, a VPN consists of a virtual Layer 3 network that is built on top of an actual Layer 3 network. The topology you use over the VPN is largely independent of the underlying network, and the protocols you run over it are completely independent of it. The Dynamic Multipoint VPN (DMVPN) is based on GRE IP logical tunnels that can be protected by adding in IPsec to encrypt the GRE IP tunnels.

All routers running Cisco IOS Release 10.3 or later releases can implement NHRP and, thus, can act as NHSs or NHCs. To obtain the base functionality of DMVPN (GRE IP+IPsec), which uses NHRP, you must run Cisco IOS Release 12.3(9), 12.3(8)T, or a later release.



### Note

---

For the latest extensions and enhancements to NHRP, you must use Cisco IOS Release 12.4 or Cisco IOS Release 12.4T.

---

## Dynamic Spoke-to-Spoke Tunnels

Spoke-to-spoke tunnels are designed to be dynamic, in that they are created only when there is data traffic to use the tunnel and they are removed when there is no longer any data traffic using the tunnel.

In addition to NHRP registration of NHCs with NHSs, NHRP provides the capability for NHCs (spokes) to find a shortcut path over the infrastructure of the network (IP network, SMDS) or build a shortcut switched virtual circuit (SVC) over a switched infrastructure network (Frame Relay and ATM) directly to another NHC (spoke), bypassing hops through the NHSs (hubs). This capability allows the building of very large NHRP NBMA networks. In this way, the bandwidth and CPU limitations of the hub do not limit the overall bandwidth of the NHRP NBMA network. This capability effectively creates a full-mesh-capable network without having to discover all possible connections beforehand. This type of network is called a dynamic-mesh network, where there is a base hub-and-spoke network of NHCs and NHSs for transporting NHRP and dynamic routing protocol information (and data traffic) and dynamic direct spoke-to-spoke links that are built when there is data traffic to use the link and torn down when the data traffic stops.

The dynamic-mesh network allows individual spoke routers to directly connect to anywhere in the NBMA network, even though they are capable of connecting only to a limited number at the same time. This functionality allows each spoke in the network to participate in the whole network up to its capabilities without limiting another spoke from participating up to its capability. If a full-mesh network were to be built, then all spokes would have to be sized to handle all possible tunnels at the same time.

For example, in a network of 1000 nodes, a full-mesh spoke would need to be large and powerful because it must always support 999 tunnels (one to every other node). In a dynamic-mesh network, a spoke needs to support only a limited number of tunnels to its NHSs (hubs) plus any currently active tunnels to other spokes. Also, if a spoke cannot build more spoke-to-spoke tunnels, then it will send its data traffic by way of the spoke-hub-spoke path. This design ensures that connectivity is always preserved, even when the preferred single hop path is not available.

## Developmental Phases of DMVPN and NHRP

The developmental phases described in this section are actually DMVPN phases combining mGRE plus NHRP and IPsec. Phase 2 and 3 are important because they provide the functionality needed to support dynamic spoke-to-spoke tunnels.

- **Phase 1** is the hub-and-spoke capability only. This phase will not be discussed here because phase 1 does not support spoke-to-spoke tunnels.
- **Phase 2** adds spoke-to-spoke capability.
- **Phase 3** changes spoke-to-spoke capability in order to scale to larger NBMA networks.

NHRP gathers the information that it needs to build spoke-to-spoke tunnels by using NHRP resolution request and reply packets that are sent via the spoke-hub-spoke path through the NBMA network. NHRP also has to be triggered (or know when) to collect this information for building the spoke-to-spoke tunnels, because it brings up the spoke-to-spoke tunnel only when there is data traffic to use it. The two ways that NHRP does this are described in the following sections.

NHRP gathers the information that it needs to build spoke-to-spoke tunnels by using NHRP resolution request and reply packets that are sent via the spoke-hub-spoke path through the NBMA network. NHRP also has to be triggered (or know when) to collect this information for building the spoke-to-spoke tunnels, because it brings up the spoke-to-spoke tunnel only when there is data traffic to use it.

The IP routing table and the routes learned by way of the hub are important when building spoke-to-spoke tunnels. Therefore, the availability of the NHSs (hubs) is critical for the functioning of an NHRP-based network. When there is only one hub and that hub goes down, the spoke removes the routes that it learned from the hub from its routing table, because it lost the hub as its routing neighbor. However, the spoke does not delete any of the spoke-to-spoke tunnels (NHRP mappings) that are now up. Even though the spoke-to-spoke tunnel is still there the spoke will not be able to use the tunnel because its routing table no longer has a route to the destination network. The spoke has a path (spoke-to-spoke tunnel), but does not know to use it (because there is no routing table entry).

In addition, when the routing entries are removed there is no trigger into NHRP for NHRP to remove NHRP mapping entries. Eventually NHRP will time out the current dynamic NHRP mapping entries that it had when the hub went down because they are not being used. Only at that time does NHRP remove the mapping entry.

In phase 2, if there still happened to be a route in the routing table (could be a static route) with the correct IP next hop, then the spoke could still use the spoke-to-spoke tunnel even when the hub is down. NHRP will not be able to refresh the mapping entry because the NHRP resolution request or response would need to go through the hub.

In phase 3, you would need a route that only points out the tunnel interface. It would not need to have the correct IP next hop (NHRP ignores the IP next-hop in phase 3). Also NHRP will be able to refresh the NHRP mapping entry, because the NHRP resolution request or response will go over the direct spoke-to-spoke tunnel.

If you have two (or more) NHS hubs within a single NBMA network (single mGRE, Frame Relay, or ATM interface), then when the first (primary) hub goes down, the spoke router will still remove the routes from the routing table that it learned from this hub, but it will also be learning the same routes (higher metric) from the second (backup) hub, so it will immediately install these routes. Therefore the spoke-to-spoke traffic would continue going over the spoke-to-spoke tunnel and be unaffected by the primary hub outage.

The following sections describe the DMVPN phases that implement the spoke-to-spoke tunnel function.

## Phase 2

In phase 2, NHRP brings up the NHC-to-NHS tunnel and a dynamic routing protocol is used to distribute routing information about all of the networks that are available behind the hub and all of the other spokes. Included in this information is the IP next hop of the destination spoke that is supporting a particular destination network.

When a data packet is forwarded, it obtains the outbound interface and the IP next hop from the matching routing table network entry. If the NHRP interface is the outbound interface, it looks for an NHRP mapping entry for that IP next hop. If there is no matching of an NHRP mapping entry, then NHRP is triggered to send an NHRP resolution request to get the mapping information (IP next-hop address to physical layer address). The NHRP registration reply packet contains this mapping information. When this information is received, the spoke has enough information to correctly encapsulate the data packet to go directly to the remote spoke, taking one hop across the infrastructure network. One of the disadvantages to this technique is that each spoke must have all of the individual routes in its routing table for all possible destination networks behind the hub and other spokes. Keeping this routing information distributed and up to date can put a significant load on the routing protocol running over the VPN.

## Phase 3

In phase 3, NHRP brings up the NHC and NHS tunnel and a dynamic routing protocol is used to distribute routing information about the networks that are available behind all of the spokes to the hub. The hub then resends this routing information out to the spokes, but in this case, the hub can summarize the routing information. It sets the IP next hop for all the network destinations to be the NHS (hub) itself. This function can significantly reduce the amount of information that the routing protocol needs to distribute from the hub to the spokes, thus reducing the load on the routing protocol running on the hub.

When a data packet is forwarded, it obtains the outbound interface and the IP next hop from the matching routing table network entry. If the NHRP interface is the outbound interface, it looks for an NHRP mapping entry for that IP next hop. In this case the IP next hop will be the hub for which it already has an NHRP mapping entry (it already has a tunnel with the hub[NHS]), so the spoke will send only the data packet to the hub.

The hub receives the data packet and checks its routing table. Because this data packet is destined for a network behind another spoke, it is forwarded back out the NHRP interface to the next hop toward that spoke. At this point the hub detects that the packet arrived and was sent back out the NHRP interface. This behavior means that the data packet is taking at least two hops within the NHRP network and therefore this path via the hub is not the optimal one-hop path. The hub therefore sends an NHRP redirect message to the spoke. The redirect message gives information to the spoke about the data packet IP destination that triggered the NHRP redirect message.

When the spoke receives the NHRP redirect, it creates and sends an NHRP resolution request for the data IP destination from the NHRP redirect message. The NHRP resolution request will be forwarded through the path to the remote spoke that services the network for that IP destination.

The remote spoke will generate an NHRP resolution reply with its own NBMA address and the whole subnet (from its routing table) that matches the data IP destination from the NHRP resolution request packet. The remote spoke will then send the NHRP resolution reply directly back to the local spoke. At this point there is now enough information for data traffic to be sent over the direct spoke-to-spoke path that was just built.



**Note** The method for phase 3 was implemented in Cisco IOS Release 12.4(6)T and uses the NHRP **ip nhrp redirect** and **ip nhrp shortcut** commands. See the [“Shortcut Switching Enhancements for NHRP in DMVPN Networks”](#) module for more information.

## Spoke Refresh Mechanism for Spoke-to-Spoke Tunnels

Spoke-to-spoke tunnels are designed to be dynamic, in that they are created only when there is data traffic to use the tunnel and they are removed when there is no longer any data traffic using the tunnel. This section describes the mechanism to refresh the spoke-to-spoke tunnel when it is still being used (no packet loss) and to detect and remove the spoke-to-spoke tunnel when it is no longer being used.

### Process Switching

Each time a data packet is switched using an NHRP mapping entry, the “used” flag is set on the mapping entry. Then when the NHRP background process runs (every 60 seconds) the following actions occur:

- If the expire time is >120 seconds and the “used” flag is set, then the “used” flag is cleared.
- If the expire time is <= 120 seconds and the “used” flag is set, then the entry is refreshed.
- If the expire time is <= 120 seconds and the “used” flag is not set, then nothing is done.

### CEF Switching

NHRP has no knowledge about when a packet is Cisco Express Forwarding (CEF) switched through the spoke-to-spoke tunnel.

When the NHRP background process runs, the following actions occur:

- If the expire time is > 120 seconds, then nothing is done.
- If the expire time is <= 120 seconds, then the corresponding CEF adjacency is marked “stale”. If the CEF adjacency is then used to switch a packet, CEF will mark the adjacency “fresh” and trigger NHRP to refresh the mapping entry.

In both the process and CEF switching cases, refreshed means that another NHRP resolution request is sent and response is needed to keep the entry from expiring. If the expiration time goes to 0 then the NHRP mapping entry is deleted. Also, if this entry is the last mapping entry with this NBMA address and if the router is CEF switching, then the CEF adjacency will be cleared and marked incomplete.

If the IPsec **tunnel protection ipsec profile** *name* command is used on an NHRP mGRE interface, then the following actions also occur:

1. The corresponding crypto socket entry is deleted.
2. The corresponding crypto map entry is deleted.
3. The corresponding IPsec security associations (SAs) and Internet Security Association and Key Management Protocol (ISAKMP) SAs are deleted.
4. Just prior to removing the ISAKMP SA, phase 2 and phase 1 delete notify messages are sent to the ISAKMP peer.
5. The ISAKMP peer deletes the corresponding IPsec SAs and ISAKMP SAs.
6. Via the crypto socket, the ISAKMP peer’s NHRP mapping entry sets its expire time set to 5 seconds, unless it is a static NHRP mapping entry.
7. When the NHRP mapping entry expires and if it is the last mapping entry with this NBMA address, then the ISAKMP peer also performs items 1 through 5.

# How to Configure NHRP

To implement basic NHRP functionality the first two tasks are required. After NHRP is operational, and depending on your network setup, you can use the other optional tasks to further configure or modify the operation of NHRP.

**Note**

---

In the following tasks, DMVPN (GRE IP with IPsec) is referred to and used for all examples because DMVPN is the primary solution where NHRP is used.

---

This section contains the following procedures:

- [Configuring a GRE Tunnel for Multipoint Operation, page 9](#) (required)
- [Enabling NHRP on an Interface, page 10](#) (required)
- [Configuring a Static IP-to-NBMA Address Mapping on a Station, page 12](#) (optional)
- [Statically Configuring a Next Hop Server, page 13](#) (optional)
- [Changing the Length of Time NBMA Addresses Are Advertised as Valid, page 14](#) (optional)
- [Specifying the NHRP Authentication String, page 15](#)
- [Configuring NHRP Server-Only Mode, page 17](#) (optional)
- [Controlling the Triggering of NHRP, page 18](#) (optional)
- [Triggering NHRP Based on Traffic Thresholds, page 21](#) (optional)
- [Controlling the NHRP Packet Rate, page 25](#) (optional)
- [Suppressing Forward and Reverse Record Options, page 27](#) (optional)
- [Specifying the NHRP Responder IP Address, page 28](#) (optional)
- [Clearing the NHRP Cache, page 29](#) (optional)

## Configuring a GRE Tunnel for Multipoint Operation

Perform this task to configure a GRE tunnel for multipoint (NMBA) operation.

You can enable a GRE tunnel to operate in multipoint fashion. A tunnel network of multipoint tunnel interfaces can be thought of as an NBMA network. When multiple GRE tunnels are configured on the same router, they must either have unique tunnel ID keys or unique tunnel source addresses. NHRP is required on mGRE tunnel interfaces because it provides the VPN-layer-IP to NBMA-layer-IP address mappings for forwarding IP data packets over the mGRE tunnel.

**Note**

---

Prior to Cisco IOS Release 12.3(11)T, all mGRE interfaces required the configuration of a tunnel ID key. After Cisco IOS Release 12.3(11)T this is optional, but if multiple GRE (mGRE) interfaces are configured on the same router without a tunnel ID key, then the mGRE interfaces be configured with unique tunnel source addresses.

---

The tunnel ID key is carried in each GRE packet, it is not carried in any NHRP messages. We do not recommend relying on this key for security purposes.

## SUMMARY STEPS

1. **enable**
2. **configure terminal**
3. **interface** *type number*
4. **tunnel mode gre multipoint**
5. **tunnel key** *key-number*
6. **ip nhrp network-id** *number*

## DETAILED STEPS

|        | Command or Action   | Purpose   |
|--------|---|---|
| Step 1 | <b>enable</b><br><br><b>Example:</b><br>Router> enable  | Enables privileged EXEC mode. <ul style="list-style-type: none"> <li>• Enter your password if prompted.</li> </ul>  |
| Step 2 | <b>configure terminal</b><br><br><b>Example:</b><br>Router# configure terminal                            | Enters global configuration mode.   |
| Step 3 | <b>interface</b> <i>type number</i><br><br><b>Example:</b><br>Router(config)# interface tunnel 100        | Configures an interface and enters interface configuration mode.  |
| Step 4 | <b>tunnel mode gre multipoint</b><br><br><b>Example:</b><br>Router(config-if)# tunnel mode gre multipoint | Enables a GRE tunnel to be used in multipoint NBMA mode.  |
| Step 5 | <b>tunnel key</b> <i>key-number</i><br><br><b>Example:</b><br>Router(config-if)# tunnel key 3             | (Optional) Sets the tunnel ID key <ul style="list-style-type: none"> <li>• See the <a href="#">“NHRP on a Multipoint Tunnel: Example”</a> section on page 33 for an example of NHRP configured on a multipoint tunnel.</li> </ul> |
| Step 6 | <b>ip nhrp network-id</b> <i>number</i><br><br><b>Example:</b><br>Router(config-if)# ip nhrp network-id 1 | Enables NHRP on the interface.  |

## Enabling NHRP on an Interface

Perform this task to enable NHRP for an interface on a router. In general, all NHRP stations within a logical NBMA network should be configured with the same network identifier.

The NHRP network ID is used to define the NHRP domain for an NHRP interface and differentiate between multiple NHRP domains or networks, when two or more NHRP domains (GRE tunnel interfaces) are available on the same NHRP node (router). The NHRP network ID is used to help keep two NHRP networks (clouds) separate from each other when both are configured on the same router.

The NHRP network ID is a local only parameter. It is significant only to the local router and is not transmitted in NHRP packets to other NHRP nodes. For this reason the actual value of the NHRP network ID configured on a router need not match the same NHRP network ID on another router where both of these routers are in the same NHRP domain. As NHRP packets arrive on a GRE interface, they are assigned to the local NHRP domain in the NHRP network ID that is configured on that interface.

**Note**

This method of assigning a network ID is similar to the Open Shortest Path First (OSPF) concept of process ID in the **router ospf process-id** command. If more than one OSPF process is configured, then the OSPF neighbors and any routing data that they provide is assigned to the OSPF process (domain) by which interfaces map to the *network* arguments under the different **router ospf process-id** configuration blocks.

We recommend that the same NHRP network ID be used on the GRE interfaces on all routers that are in the same NHRP network. It is then easier to track which GRE interfaces are members of which NHRP network.

NHRP domains (network IDs) can be unique on each GRE tunnel interface on a router. This is required when running DMVPN phase 1 or phase 2 or when using a tunnel key on the GRE interfaces. These unique IDs place each GRE interface into a different NHRP domain, which is equivalent to each being in a unique DMVPN.

NHRP domains can span across GRE tunnel interfaces on a route. This option is available when running DMVPN phase 3 and not using a tunnel key on the GRE tunnel interfaces. In this case the effect of using the same NHRP network ID on the GRE tunnel interfaces is to merge the two GRE interfaces into a single NHRP network (DMVPN network).

**SUMMARY STEPS**

1. **enable**
2. **configure terminal**
3. **interface** *type number*
4. **ip address** *ip-address network-mask*
5. **ip nhrp network-id** *number*
6. **end**

## DETAILED STEPS

|        | Command or Action  | Purpose   |
|--------|--|---|
| Step 1 | <b>enable</b><br><br><b>Example:</b><br>Router> enable   | Enables privileged EXEC mode.<br><ul style="list-style-type: none"><li>• Enter your password if prompted.</li></ul> |
| Step 2 | <b>configure terminal</b><br><br><b>Example:</b><br>Router# configure terminal   | Enters global configuration mode.   |
| Step 3 | <b>interface</b> <i>type number</i><br><br><b>Example:</b><br>Router(config)# interface tunnel 100                                 | Configures an interface and enters interface configuration mode.  |
| Step 4 | <b>ip address</b> <i>ip-address network-mask</i><br><br><b>Example:</b><br>Router(config-if)# ip address 10.0.0.1<br>255.255.255.0 | Enables IP and gives the interface an IP address.   |
| Step 5 | <b>ip nhrp network-id</b> <i>number</i><br><br><b>Example:</b><br>Router(config-if)# ip nhrp network-id 1                          | Enables NHRP on the interface.  |
| Step 6 | <b>end</b><br><br><b>Example:</b><br>Router(config)# end   | Exits interface configuration mode and returns to privileged EXEC mode.   |

## Configuring a Static IP-to-NBMA Address Mapping on a Station

Perform this task to configure static IP-to-NBMA address mapping on a station (host or router). To enable IP multicast and broadcast packets to be sent to the statically configured station, use the **ip nhrp map multicast nbma-address** command. This command is required on multipoint GRE tunnels and not required on point-point RE tunnels.

To participate in NHRP, a station connected to an NBMA network must be configured with the IP and NBMA addresses of its NHSs. The format of the NBMA address depends on the medium you are using. For example, GRE uses a network service access point (NSAP) address, Ethernet uses a MAC address, and SMDS uses an E.164 address.

These NHSs may also be the default or peer routers of the station, so their addresses can be obtained from the network layer forwarding table of the station.

If the station is attached to several link layer networks (including logical NBMA networks), the station should also be configured to receive routing information from its NHSs and peer routers so that it can determine which IP networks are reachable through which link layer networks.

Perform this task to configure static IP-to-NBMA address mapping on a station (host or router). To enable IP multicast and broadcast packets to be sent to the statically configured station, use the **ip nhrp map multicast nbma-address** command. This step is required on multipoint GRE tunnels and not required on point-point RE tunnels.

**Note**

The IGP routing protocol uses IP multicast or broadcast, so the **ip nhrp map multicast** command, though optional, is often required.

**SUMMARY STEPS**

1. **enable**
2. **configure terminal**
3. **interface** *type number*
4. **ip nhrp map** *ip-address nbma-address*
5. **ip nhrp map multicast** *nbma-address*

**DETAILED STEPS**

|               | <b>Command or Action</b>   | <b>Purpose</b>   |
|---------------|--|--|
| <b>Step 1</b> | <b>enable</b><br><br><b>Example:</b><br>Router> enable   | Enables privileged EXEC mode. <ul style="list-style-type: none"> <li>• Enter your password if prompted.</li> </ul>   |
| <b>Step 2</b> | <b>configure terminal</b><br><br><b>Example:</b><br>Router# configure terminal   | Enters global configuration mode.  |
| <b>Step 3</b> | <b>interface</b> <i>type number</i><br><br><b>Example:</b><br>Router(config)# interface tunnel 100                                 | Configures an interface and enters interface configuration mode.   |
| <b>Step 4</b> | <b>ip nhrp map</b> <i>ip-address nbma-address</i><br><br><b>Example:</b><br>Router(config-if)# ip nhrp map 10.0.0.2<br>172.16.1.2  | Configures static IP-to-NBMA address mapping on the station.   |
| <b>Step 5</b> | <b>ip nhrp map multicast</b> <i>nbma-address</i><br><br><b>Example:</b><br>Router(config-if)# ip nhrp map multicast<br>172.16.1.12 | (Optional) Adds an NBMA address to receive multicast or broadcast packets sent out the interface.<br><br><b>Note</b> This command is not required on point-to-point GRE tunnels. |

**Statically Configuring a Next Hop Server**

Perform this task to statically configure a Next Hop Server.

An NHS normally uses the network layer forwarding table to determine where to forward NHRP packets and to find the egress point from an NBMA network. An NHS may also be statically configured with a set of IP address prefixes that correspond to the IP addresses of the stations it serves, and their logical NBMA network identifiers.

## SUMMARY STEPS

1. **enable**
2. **configure terminal**
3. **interface** *type number*
4. **ip nhrp nhs** *nhs-address* [*net-address* [*netmask*]]

## DETAILED STEPS

|        | Command or Action  | Purpose   |
|--------|--|---|
| Step 1 | <b>enable</b><br><br><b>Example:</b><br>Router> enable   | Enables privileged EXEC mode. <ul style="list-style-type: none"> <li>• Enter your password if prompted.</li> </ul>  |
| Step 2 | <b>configure terminal</b><br><br><b>Example:</b><br>Router# configure terminal   | Enters global configuration mode.   |
| Step 3 | <b>interface</b> <i>type number</i><br><br><b>Example:</b><br>Router(config)# interface tunnel 100   | Configures an interface and enters interface configuration mode.  |
| Step 4 | <b>ip nhrp nhs</b> <i>nhs-address</i> [ <i>net-address</i> [ <i>netmask</i> ]]<br><br><b>Example:</b><br>Router(config-if)# ip nhrp nhs 10.0.0.2 | Statically configures a Next Hop Server. <ul style="list-style-type: none"> <li>• To configure multiple networks that the Next Hop Server serves, repeat the <b>ip nhrp nhs</b> command with the same Next Hop Server address, but different IP network addresses.</li> <li>• To configure additional Next Hop Servers, repeat the <b>ip nhrp nhs</b> command.</li> </ul> |

## Changing the Length of Time NBMA Addresses Are Advertised as Valid

Perform this task to change the length of time that NBMA addresses are advertised as valid in positive NHRP responses. In this context, *advertised* means how long the Cisco IOS XE software tells other routers to keep the address mappings it is providing in NHRP responses. The default length of time is 7200 seconds (2 hours).

This configuration controls how long a spoke-to-spoke shortcut path will stay up after it is no longer used or how often the spoke-to-spoke short-cut path mapping entry will be refreshed if it is still being used. We recommend that a value from 300 to 600 seconds be used.

The **ip nhrp holdtime** command controls how often the NHRP NHC will send NHRP registration requests to its configured NHRP NHSs. The default is to send NHRP registrations every one-third the NHRP holdtime value (default = 2400 seconds (40 minutes)). The optional **ip nhrp registration timeout value** command can be used to set the interval for sending NHRP registration requests independently from the NHRP holdtime.

## SUMMARY STEPS

1. **enable**
2. **configure terminal**
3. **interface** *type number*
4. **ip nhrp holdtime** *seconds*
5. **ip nhrp registration timeout** *seconds*

## DETAILED STEPS

|        | Command or Action  | Purpose  |
|--------|--|--|
| Step 1 | <b>enable</b><br><br><b>Example:</b><br>Router> enable   | Enables privileged EXEC mode. <ul style="list-style-type: none"> <li>• Enter your password if prompted.</li> </ul>   |
| Step 2 | <b>configure terminal</b><br><br><b>Example:</b><br>Router# configure terminal   | Enters global configuration mode.  |
| Step 3 | <b>interface</b> <i>type number</i><br><br><b>Example:</b><br>Router(config)# interface tunnel 100                               | Configures an interface and enters interface configuration mode.   |
| Step 4 | <b>ip nhrp holdtime</b> <i>seconds</i><br><br><b>Example:</b><br>Router(config-if)# ip nhrp holdtime 600                         | Changes the number of seconds that NHRP NBMA addresses are advertised as valid in positive NHRP responses. <ul style="list-style-type: none"> <li>• In this example, NHRP NBMA addresses are advertised as valid in positive NHRP responses for 10 minutes.</li> </ul>                   |
| Step 5 | <b>ip nhrp registration timeout</b> <i>seconds</i><br><br><b>Example:</b><br>Router(config-if)# ip nhrp registration timeout 100 | (Optional) Changes the interval that NHRP NHCs send NHRP registration requests to configured NHRP NHSs. <ul style="list-style-type: none"> <li>• In this example, NHRP registration requests are now sent every 100 seconds (default value is one third NHRP holdtime value).</li> </ul> |

## Specifying the NHRP Authentication String

Perform this task to specify the authentication string for NHRP on an interface.

Configuring an authentication string ensures that only routers configured with the same string can communicate using NHRP. Therefore, if the authentication scheme is to be used, the same string must be configured in all devices configured for NHRP on a fabric.

**Note**

---

We recommend using an NHRP authentication string, especially to help keep multiple NHRP domains separate from each other. The NHRP authentication string is not encrypted, so it cannot be used as a true authentication for an NHRP node trying to enter the NHRP network.

---

**SUMMARY STEPS**

1. **enable**
2. **configure terminal**
3. **interface** *type number*
4. **ip nhrp authentication** *string*
5. **exit**
6. **show ip nhrp** [**dynamic** | **static**] [*type number*]
7. **show ip nhrp traffic**
8. **show ip nhrp nhs** [**detail**]

## DETAILED STEPS

|        | Command or Action  | Purpose  |
|--------|--|--|
| Step 1 | <b>enable</b><br><br><b>Example:</b><br>Router> enable   | Enables privileged EXEC mode.<br><ul style="list-style-type: none"><li>Enter your password if prompted.</li></ul>  |
| Step 2 | <b>configure terminal</b><br><br><b>Example:</b><br>Router# configure terminal   | Enters global configuration mode.  |
| Step 3 | <b>interface</b> <i>type number</i><br><br><b>Example:</b><br>Router(config)# interface tunnel 100                           | Configures an interface and enters interface configuration mode.   |
| Step 4 | <b>ip nhrp authentication</b> <i>string</i><br><br><b>Example:</b><br>Router(config-if)# ip nhrp authentication specialxx    | Specifies an authentication string.<br><ul style="list-style-type: none"><li>All routers configured with NHRP within one logical NBMA network must share the same authentication string.</li></ul> |
| Step 5 | <b>exit</b><br><br><b>Example:</b><br>Router(config-if)# exit  | Exits interface configuration mode and returns to privileged EXEC mode.  |
| Step 6 | <b>show ip nhrp</b> [ <b>dynamic</b>   <b>static</b> ] [ <i>type number</i> ]<br><br><b>Example:</b><br>Router# show ip nhrp | Displays the IP NHRP cache, which can be limited to dynamic or static cache entries for a specific interface.  |
| Step 7 | <b>show ip nhrp traffic</b><br><br><b>Example:</b><br>Router# show ip nhrp traffic   | Displays NHRP traffic statistics.  |
| Step 8 | <b>show ip nhrp nhs</b> [ <b>detail</b> ]<br><br><b>Example:</b><br>Router# show ip nhrp nhs detail                          | Displays NHRP holdtime details.  |

## Configuring NHRP Server-Only Mode

Perform this task to configure NHRP server-only mode.

You can configure an interface so that it cannot initiate NHRP resolution requests to establish NHRP shortcut SVCs but can respond only to NHRP resolution requests. Configure NHRP server-only mode on routers you do not want placing NHRP resolution requests.

If an interface is placed in NHRP server-only mode, you have the option to specify the **ip nhrp server-only [non-caching]** command keyword. In this case, NHRP does not store mapping information in the NHRP cache, such as NHRP responses that go through the router. To save memory and block building of NHRP shortcuts, the non-caching option is generally used on a router located between two other NHRP routers (NHRP hubs).

Perform this task to configure NHRP server-only mode.

## SUMMARY STEPS

1. **enable**
2. **configure terminal**
3. **interface** *type number*
4. **ip nhrp server-only [non-caching]**

## DETAILED STEPS

|        | Command or Action   | Purpose  |
|--------|---|--|
| Step 1 | <b>enable</b><br><br><b>Example:</b><br>Router> enable  | Enables privileged EXEC mode. <ul style="list-style-type: none"> <li>• Enter your password if prompted.</li> </ul> |
| Step 2 | <b>configure terminal</b><br><br><b>Example:</b><br>Router# configure terminal  | Enters global configuration mode.  |
| Step 3 | <b>interface</b> <i>type number</i><br><br><b>Example:</b><br>Router(config)# interface tunnel 100                    | Configures an interface and enters interface configuration mode.   |
| Step 4 | <b>ip nhrp server-only [non-caching]</b><br><br><b>Example:</b><br>Router(config-if)# ip nhrp server-only non-caching | Configures NHRP server-only mode.  |

## Controlling the Triggering of NHRP

There are two ways to control when NHRP is triggered on any platform. These methods are described in the following sections:

- [Triggering NHRP on a Per-Destination Basis, page 18](#)
- [Triggering NHRP on a Packet Count Basis, page 20](#)

### Triggering NHRP on a Per-Destination Basis

Perform the following task to trigger NHRP on a per-destination basis.

You can specify an IP access list that is used to decide which IP packets can trigger the sending of NHRP resolution requests. By default, all non-NHRP packets trigger NHRP resolution requests. To limit which IP packets trigger NHRP resolution requests, define an access list and then apply it to the interface.

**Note**

NHRP resolution requests are used to build direct paths between two NHRP nodes. Even though certain traffic is excluded from triggering the building of this path, if the path is already built then this “excluded” traffic will use the direct path.

**SUMMARY STEPS**

1. **enable**
2. **configure terminal**
3. **access-list** *access-list-number* {deny | permit} *source* [*source-wildcard*]  
or  
**access-list** *access-list-number* {deny | permit} *protocol source source-wildcard destination destination-wildcard* [**precedence** *precedence*] [**tos** *tos*] [**established**] [**log**]
4. **interface** *type number*
5. **ip nhrp interest** *access-list-number*

## DETAILED STEPS

|        | Command or Action   | Purpose  |
|--------|---|--|
| Step 1 | <p><b>enable</b></p> <p><b>Example:</b><br/>Router&gt; enable</p>   | <p>Enables privileged EXEC mode.</p> <ul style="list-style-type: none"> <li>Enter your password if prompted.</li> </ul>  |
| Step 2 | <p><b>configure terminal</b></p> <p><b>Example:</b><br/>Router# configure terminal</p>  | <p>Enters global configuration mode.</p>   |
| Step 3 | <p><b>access-list</b> <i>access-list-number</i> {<b>deny</b>   <b>permit</b>}<br/><i>source</i> [<i>source-wildcard</i>]<br/>or</p> <p><b>access-list</b> <i>access-list-number</i> {<b>deny</b>   <b>permit</b>}<br/><i>protocol source source-wildcard destination</i><br/><i>destination-wildcard</i> [<b>precedence</b> <i>precedence</i>]<br/>[<b>tos</b> <i>tos</i>] [<b>established</b>] [<b>log</b>]</p> <p><b>Example:</b><br/>Router(config)# access-list 101 permit ip any<br/>any<br/>or<br/>Router(config)# access-list 101 deny ip any<br/>10.3.0.0 0.0.255.255</p> | <p>Defines a standard or extended IP access list.</p>  |
| Step 4 | <p><b>interface</b> <i>type number</i></p> <p><b>Example:</b><br/>Router(config)# interface tunnel 100</p>  | <p>Configures an interface and enters interface configuration mode.</p>  |
| Step 5 | <p><b>ip nhrp interest</b> <i>access-list-number</i></p> <p><b>Example:</b><br/>Router(config-if)# ip nhrp interest 101</p>   | <p>Specifies an IP access list that controls NHRP requests.</p> <ul style="list-style-type: none"> <li>In this example, only the packets that pass extended access list 101 are subject to the default SVC triggering and teardown rates.</li> </ul> |

## Triggering NHRP on a Packet Count Basis

By default, when the software attempts to send a data packet to a destination for which it has determined that NHRP can be used, it sends an NHRP request for that destination. Perform this task to configure the system to wait until a specified number of data packets have been sent to a particular destination before NHRP is attempted.

## SUMMARY STEPS

- enable**
- configure terminal**
- interface** *type number*
- ip nhrp use** *usage-count*

## DETAILED STEPS

|        | Command or Action   | Purpose  |
|--------|---|--|
| Step 1 | <code>enable</code><br><br><b>Example:</b><br>Router> enable                                      | Enables privileged EXEC mode. <ul style="list-style-type: none"> <li>Enter your password if prompted.</li> </ul>   |
| Step 2 | <code>configure terminal</code><br><br><b>Example:</b><br>Router# configure terminal              | Enters global configuration mode.  |
| Step 3 | <code>interface type number</code><br><br><b>Example:</b><br>Router(config)# interface tunnel 100 | Configures an interface and enters interface configuration mode.   |
| Step 4 | <code>ip nhrp use usage-count</code><br><br><b>Example:</b><br>Router(config-if)# ip nhrp use 5   | Specifies how many data packets are sent to a destination before NHRP is attempted. <ul style="list-style-type: none"> <li>In this example, if in the first minute five packets are sent to the first destination and five packets are sent to a second destination, then a single NHRP request is generated for the second destination.</li> <li>If in the second minute the same traffic is generated and no NHRP responses have been received, then the system resends its request for the second destination.</li> </ul> |

## Triggering NHRP Based on Traffic Thresholds

NHRP can run on Cisco Express Forwarding platforms when NHRP runs with Border Gateway Protocol (BGP). You can configure NHRP to initiate SVCs once a configured traffic rate is reached. Similarly, SVCs can be torn down when traffic falls to another configured rate.

You can configure the traffic rate that must be reached before NHRP sets up or tears down an SVC. Because SVCs are created only for burst traffic, you can conserve resources.

To configure the NHRP triggering and teardown of SVCs based on traffic rate, perform the following tasks. The first task is required; the second and third tasks are optional.

- [Changing the Rate for Triggering SVCs, page 21](#) (required)
- [Changing the Sampling Time Period and Sampling Rate, page 23](#) (optional)
- [Applying the Triggering and Teardown Rates to Specific Destinations, page 24](#) (optional)

### Changing the Rate for Triggering SVCs

Perform this task to change the number of kilobits per second (kbps) at which NHRP sets up or tears down the SVC to this destination.

When NHRP runs with BGP, there is a way to control the triggering of NHRP packets. This method consists of SVCs being initiated based on the input traffic rate to a given BGP next hop.

When BGP discovers a BGP next hop and enters this BGP route into the routing table, an NHRP request is sent to the BGP next hop. When an NHRP reply is received, a subsequent route is put in the NHRP cache that directly corresponds to the BGP next hop.

A new NHRP request is sent to the same BGP next hop to repopulate the NHRP cache. When an NHRP cache entry is generated, a subsequent map statement to the same BGP next hop is also created.

Aggregate traffic to each BGP next hop is measured and monitored. Once the aggregate traffic has met or exceeded the configured trigger rate, NHRP creates an SVC and sends traffic directly to that destination router. The router tears down the SVC to the specified destinations when the aggregate traffic rate falls to or below the configured teardown rate.

By default, NHRP will set up an SVC for a destination when aggregate traffic for that destination is more than 1 kbps over a running average of 30 seconds. Similarly, NHRP will tear down the SVC when the traffic for that destination drops to 0 kbps over a running average of 30 seconds. There are several ways to change the rate at which SVC setup or teardown occurs. You can change the number of kbps thresholds, or the load interval, or both.

## Prerequisites

Before you configure the feature whereby NHRP initiation is based on traffic rate, the following conditions must exist in the router:

- GRE must be configured.
- CEF switching or distributed CEF (dCEF) switching must be enabled.
- BGP must be configured on all routers in the network where these enhancements are running.

If your network has CEF switching or dCEF switching and you want NHRP to work (whether with default values or changed values), configure the **ip cef accounting non-recursive** command.

## Restrictions

Cisco IOS releases prior to Release 12.0 implemented NHRP draft version 4. Cisco IOS Release 12.0 and later releases implement NHRP draft version 11. These versions are not compatible. Therefore, all routers running NHRP in a network must run the same version of NHRP in order to communicate with each other. All routers must run Cisco IOS Release 12.0 and later releases, or all routers must run a release prior to Release 12.0, but not a combination of the two.

## SUMMARY STEPS

1. **enable**
2. **configure terminal**
3. **interface** *type number*
4. **ip nhrp trigger-svc** *trigger-threshold teardown-threshold*

## DETAILED STEPS

|        | Command or Action   | Purpose  |
|--------|---|--|
| Step 1 | <b>enable</b><br><br><b>Example:</b><br>Router> enable  | Enables privileged EXEC mode. <ul style="list-style-type: none"> <li>Enter your password if prompted.</li> </ul>   |
| Step 2 | <b>configure terminal</b><br><br><b>Example:</b><br>Router# configure terminal  | Enters global configuration mode.  |
| Step 3 | <b>interface</b> <i>type number</i><br><br><b>Example:</b><br>Router(config)# interface tunnel 100  | Configures an interface and enters interface configuration mode.   |
| Step 4 | <b>ip nhrp trigger-svc</b> <i>trigger-threshold</i><br><i>teardown-threshold</i><br><br><b>Example:</b><br>Router(config-if)# ip nhrp trigger-svc 100 5 | Changes the rate at which NHRP sets up or tears down SVCs. <ul style="list-style-type: none"> <li>In this example, the triggering and teardown thresholds are set to 100 kbps and 5 kbps, respectively.</li> </ul> |

## Changing the Sampling Time Period and Sampling Rate

You can change the length of time over which the average trigger rate or teardown rate is calculated. By default, the period is 30 seconds; the range is from 30 to 300 seconds in 30-second increments. This period is for calculations of aggregate traffic rate internal to Cisco IOS XE software only, and it represents a worst-case time period for taking action. In some cases, the software will act sooner, depending on the ramp-up and fall-off rate of the traffic.

If your Cisco hardware has a Virtual Interface Processor, version 2 adapter, you must perform this task to change the sampling time. By default, the port adapter sends the traffic statistics to the Route Processor every 10 seconds. If you are using NHRP in dCEF switching mode, you must change this update rate to 5 seconds.

Perform this task to change the sampling time period and the sampling rate.

## SUMMARY STEPS

- enable**
- configure terminal**
- ip cef traffic-statistics** [*load-interval seconds*]
- ip cef traffic-statistics** [*update-rate seconds*]

## DETAILED STEPS

|        | Command or Action  | Purpose  |
|--------|--|--|
| Step 1 | <b>enable</b><br><br><b>Example:</b><br>Router> enable   | Enables privileged EXEC mode.<br><ul style="list-style-type: none"><li>Enter your password if prompted.</li></ul>  |
| Step 2 | <b>configure terminal</b><br><br><b>Example:</b><br>Router# configure terminal   | Enters global configuration mode.  |
| Step 3 | <b>ip cef traffic-statistics [load-interval seconds]</b><br><br><b>Example:</b><br>Router(config)# ip cef traffic-statistics load-interval 120 | Changes the length of time in a sampling period during which trigger and teardown thresholds are averaged.<br><ul style="list-style-type: none"><li>In this example, the triggering and teardown thresholds are calculated based on an average over 120 seconds.</li></ul> |
| Step 4 | <b>ip cef traffic-statistics [update-rate seconds]</b><br><br><b>Example:</b><br>Router(config)# ip cef traffic-statistics update-rate 5       | Specifies the frequency that the port adapter sends the accounting statistics to the RP.<br><ul style="list-style-type: none"><li>When using NHRP in distributed CEF switching mode, this value must be set to 5 seconds. The default value is 10 seconds.</li></ul>       |

## Applying the Triggering and Teardown Rates to Specific Destinations

Perform this task to impose the triggering and teardown rates on certain destinations. By default, all destinations are measured and monitored for NHRP triggering.

## SUMMARY STEPS

- enable**
- configure terminal**
- access-list** *access-list-number* {deny | permit} *source* [*source-wildcard*]  
or  
**access-list** *access-list-number* {deny | permit} *protocol source source-wildcard destination destination-wildcard* [precedence *precedence*] [tos *tos*] [log]
- interface** *type number*
  - ip nhrp interest** *access-list-number*

## DETAILED STEPS

|        | Command or Action  | Purpose  |
|--------|--|--|
| Step 1 | <p><b>enable</b></p> <p><b>Example:</b><br/>Router&gt; enable</p>  | <p>Enables privileged EXEC mode.</p> <ul style="list-style-type: none"> <li>Enter your password if prompted.</li> </ul>  |
| Step 2 | <p><b>configure terminal</b></p> <p><b>Example:</b><br/>Router# configure terminal</p>   | <p>Enters global configuration mode.</p>   |
| Step 3 | <p><b>access-list</b> <i>access-list-number</i> {<b>deny</b>   <b>permit</b>}<br/><i>source</i> [<i>source-wildcard</i>]<br/>or</p> <p><b>access-list</b> <i>access-list-number</i> {<b>deny</b>   <b>permit</b>}<br/><i>protocol source source-wildcard destination</i><br/><i>destination-wildcard</i> [<b>precedence</b> <i>precedence</i>]<br/>[<b>tos</b> <i>tos</i>] [<b>log</b>]</p> <p><b>Example:</b><br/>Router(config)# access-list 101 permit ip any any<br/>or<br/>Router(config)# access-list 101 deny ip any 10.3.0.0 0.0.255.255</p> | <p>Defines a standard or extended IP access list.</p> <ul style="list-style-type: none"> <li>In the example an extended access list is defined.</li> </ul>   |
| Step 4 | <p><b>interface</b> <i>type number</i></p> <p><b>Example:</b><br/>Router(config)# interface tunnel 100</p>   | <p>Configures an interface and enters interface configuration mode.</p>  |
| Step 5 | <p><b>ip nhrp interest</b> <i>access-list-number</i></p> <p><b>Example:</b><br/>Router(config-if)# ip nhrp interest 101</p>  | <p>Specifies an IP access list that controls NHRP requests.</p> <ul style="list-style-type: none"> <li>In this example, only the packets that pass extended access list 101 are subject to the default SVC triggering and teardown rates.</li> </ul> |

## Controlling the NHRP Packet Rate

Perform this task to change the maximum rate at which NHRP packets will be handled.

There is the maximum value (max-send interval) for the number of NHRP messages that the local NHRP process can handle within a set period of time. This limit protects the router against events like a runaway NHRP process sending NHRP requests or an application (worm) that is doing an IP address scan that is triggering many spoke-to-spoke tunnels.

The larger the max-send interval the more NHRP packets the system can process and send. These messages do not use much memory and the CPU usage is not very large per message; however, excessive messages causing excessive CPU usage can degrade system performance.

To set a reasonable max-send-interval, consider the following information:

- Number of spoke routers being handled by this hub and how often they send NHRP registration requests. To support this load you would need:

Number of spokes/registration timeout \* max-send interval

For example, 500 spokes with a 100-second registration timeout would equate as follows:

max-send interval =  $500/100*10 = 50$

- The maximum number of spoke-to-spoke tunnels that are expected to be up at any one time across the NBMA network:

spoke-to-spoke tunnels/NHRP holdtime \* max-send interval

This would cover spoke-to-spoke tunnel creation and the refreshing of spoke-to-spoke tunnels that are used for longer periods of time.

Then add these values together and multiply the result by 1.5 or 2.0 to give a buffer.

- The max-send interval can be used to keep the long-term average number of NHRP messages allowed to be sent constant, but allow greater peaks.

By default, the maximum rate at which the software sends NHRP packets is five packets per 10 seconds. The software maintains a per-interface quota of NHRP packets (whether generated locally or forwarded) that can be sent.

## SUMMARY STEPS

1. **enable**
2. **configure terminal**
3. **interface** *type number*
4. **ip nhrp max-send** *pkt-count every interval*

## DETAILED STEPS

|        | Command or Action   | Purpose  |
|--------|---|--|
| Step 1 | <b>enable</b><br><br><b>Example:</b><br>Router> enable  | Enables privileged EXEC mode. <ul style="list-style-type: none"> <li>Enter your password if prompted.</li> </ul> |
| Step 2 | <b>configure terminal</b><br><br><b>Example:</b><br>Router# configure terminal  | Enters global configuration mode.  |
| Step 3 | <b>interface</b> <i>type number</i><br><br><b>Example:</b><br>Router(config)# interface tunnel 100                                | Configures an interface and enters interface configuration mode.   |
| Step 4 | <b>ip nhrp max-send</b> <i>pkt-count every interval</i><br><br><b>Example:</b><br>Router(config-if)# ip nhrp max-send 10 every 10 | In this example, ten NHRP packets can be sent from the interface every 10 seconds (twice the default rate).      |

## Suppressing Forward and Reverse Record Options

To dynamically detect link layer filtering in NBMA networks (for example, SMDS address screens), and to provide loop detection and diagnostic capabilities, NHRP incorporates a Route Record in request and reply packets. The Route Record options contain the network (and link layer) addresses of all intermediate Next Hop Servers between the source and destination (in the forward direction) and between the destination and source (in the reverse direction).

By default, Forward Record options and Reverse Record options are included in NHRP request and reply packets. Perform this task to suppress forward and reverse record options.

**Note**

Forward and Reverse Record information is required for the proper operation of NHRP, especially in a DMVPN network. Therefore you must not configure suppression of this information.

## SUMMARY STEPS

- enable**
- configure terminal**
- interface** *type number*
- no ip nhrp record**

## DETAILED STEPS

|        | Command or Action  | Purpose   |
|--------|--|---|
| Step 1 | <b>enable</b><br><br><b>Example:</b><br>Router> enable   | Enables privileged EXEC mode.<br><ul style="list-style-type: none"><li>• Enter your password if prompted.</li></ul> |
| Step 2 | <b>configure terminal</b><br><br><b>Example:</b><br>Router# configure terminal                     | Enters global configuration mode.   |
| Step 3 | <b>interface</b> <i>type number</i><br><br><b>Example:</b><br>Router(config)# interface tunnel 100 | Configures an interface and enters interface configuration mode.  |
| Step 4 | <b>no ip nhrp record</b><br><br><b>Example:</b><br>Router(config-if)# no ip nhrp record            | Suppresses Forward and Reverse Record options.  |

## Specifying the NHRP Responder IP Address

An NHRP requester that wants to know which Next Hop Server generates an NHRP reply packet can include the responder address option in its NHRP request packet. The Next Hop Server that generates the NHRP reply packet then complies by inserting its own IP address in the NHRP reply. The Next Hop Server uses the primary IP address of the specified interface.

Perform this task to specify which interface the Next Hop Server uses for the NHRP responder IP address.

## SUMMARY STEPS

1. **enable**
2. **configure terminal**
3. **interface** *type number*
4. **ip nhrp responder** *type number*

## DETAILED STEPS

|        | Command or Action   | Purpose   |
|--------|---|---|
| Step 1 | <b>enable</b><br><br><b>Example:</b><br>Router> enable  | Enables privileged EXEC mode.<br><ul style="list-style-type: none"><li>• Enter your password if prompted.</li></ul>   |
| Step 2 | <b>configure terminal</b><br><br><b>Example:</b><br>Router# configure terminal                                      | Enters global configuration mode.   |
| Step 3 | <b>interface</b> <i>type number</i><br><br><b>Example:</b><br>Router(config)# interface serial 0                    | Configures a serial interface and enters interface configuration mode.  |
| Step 4 | <b>ip nhrp responder</b> <i>type number</i><br><br><b>Example:</b><br>Router(config-if)# ip nhrp responder serial 0 | Specifies which interface the Next Hop Server uses for the NHRP responder IP address.<br><ul style="list-style-type: none"><li>• In this example, any NHRP requests for the Responder Address will cause this router acting as a next-hop server to supply the primary IP address of serial interface 0 in the NHRP reply packet.</li><li>• If an NHRP reply packet being forwarded by a Next Hop Server contains the IP address of that server, the Next Hop Server generates an error indication of type “NHRP Loop Detected” and discards the reply.</li></ul> |

## Clearing the NHRP Cache

The NHRP cache can contain entries of statically configured NHRP mappings and dynamic entries caused by the Cisco IOS XE software learning addresses from NHRP packets. To clear statically configured entries, use the **no ip nhrp map** command in interface configuration mode.

Perform the following task to clear the NHRP cache.

## SUMMARY STEPS

1. **enable**
2. **clear ip nhrp** [*ip-address*] [*ip-mask*]

## DETAILED STEPS

|        | Command or Action   | Purpose   |
|--------|---|---|
| Step 1 | <b>enable</b><br><br><b>Example:</b><br>Router> enable  | Enables privileged EXEC mode. <ul style="list-style-type: none"> <li>• Enter your password if prompted.</li> </ul>  |
| Step 2 | <b>clear ip nhrp</b> [ <i>ip-address</i> ] [ <i>ip-mask</i> ]<br><br><b>Example:</b><br>Router# clear ip nhrp | Clears the IP NHRP cache of dynamic entries. <ul style="list-style-type: none"> <li>• This command does not clear any static (configured) IP to NBMA address mappings from the NHRP cache.</li> </ul> |

## Configuration Examples for NHRP

This section provides the following configuration examples:

- [Physical Network Designs for Logical NBMA: Examples, page 30](#)
- [Applying NHRP Rates to Specific Destinations: Example, page 32](#)
- [NHRP on a Multipoint Tunnel: Example, page 33](#)
- [Show NHRP: Examples, page 34](#)

### Physical Network Designs for Logical NBMA: Examples

A logical NBMA network is considered the group of interfaces and hosts participating in NHRP and having the same network identifier. [Figure 2](#) illustrates two logical NBMA networks (shown as circles) configured over a single physical NBMA network. Router A can communicate with routers B and C because they share the same network identifier (2). Router C can also communicate with routers D and E because they share network identifier 7. After address resolution is complete, router A can send IP packets to router C in one hop, and router C can send them to router E in one hop, as shown by the dotted lines.

**Figure 2** Two Logical NBMA Networks over One Physical NBMA Network

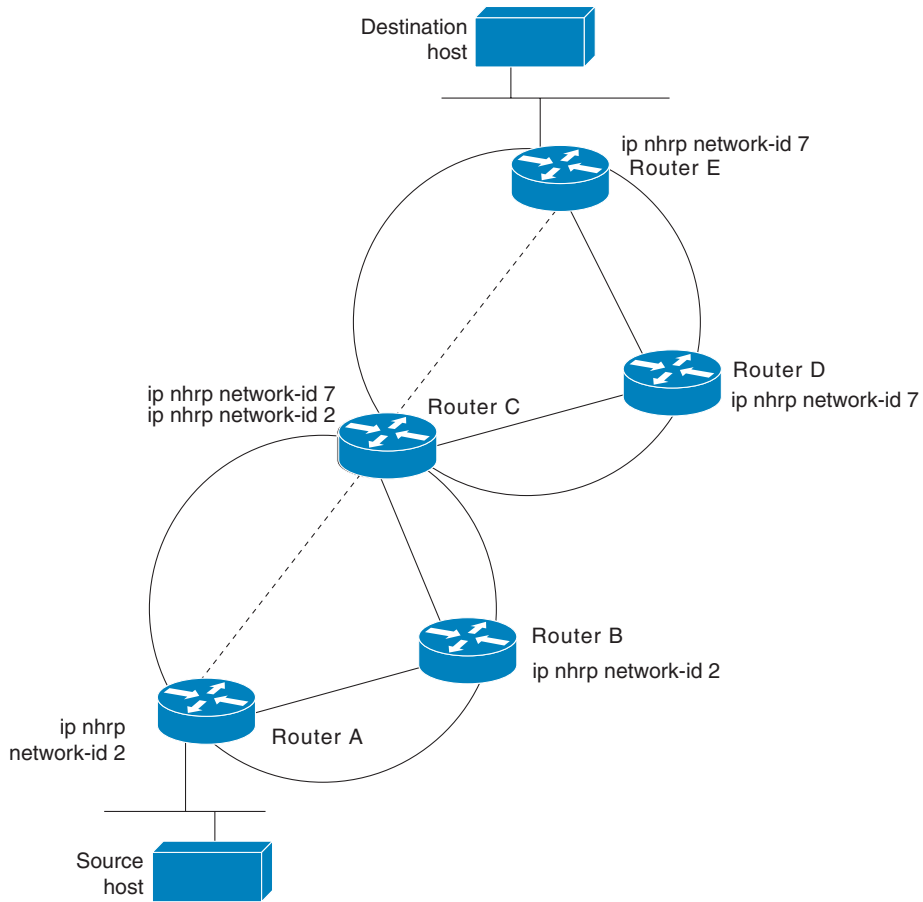

— = Statically configured tunnel endpoints or permanent virtual circuits  
 - - - - = Dynamically created virtual circuits

205457

The physical configuration of the five routers in [Figure 2](#) might actually be that shown in [Figure 3](#). The source host is connected to router A and the destination host is connected to router E. The same switch serves all five routers, making one physical NBMA network.

**Figure 3** Physical Configuration of a Sample NBMA Network

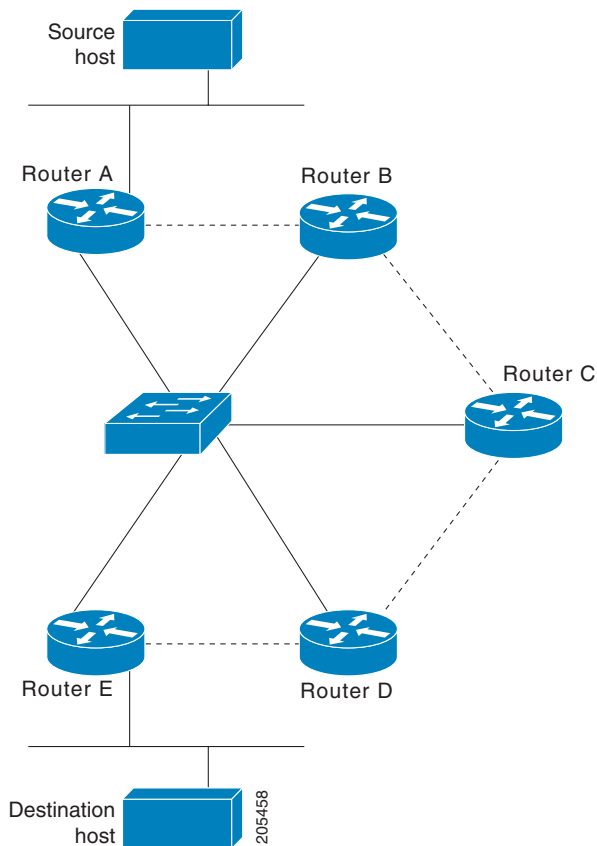

Refer again to [Figure 2](#). Initially, before NHRP has resolved any NBMA addresses, IP packets from the source host to the destination host travel through all five routers connected to the switch before reaching the destination. When router A first forwards the IP packet toward the destination host, router A also generates an NHRP request for the IP address of the destination host. The request is forwarded to router C, whereupon a reply is generated. Router C replies because it is the egress router between the two logical NBMA networks.

Similarly, router C generates an NHRP request of its own, to which router E replies. In this example, subsequent IP traffic between the source and the destination still requires two hops to traverse the NBMA network, because the IP traffic must be forwarded between the two logical NBMA networks. Only one hop would be required if the NBMA network were not logically divided.

## Applying NHRP Rates to Specific Destinations: Example

In the following example, only the packets that pass extended access list 101 are subject to the default SVC triggering and teardown rates:

```
interface tunnel 100
 ip nhrp interest 101
!
access-list 101 permit ip any any
access-list 101 deny ip any 10.3.0.0 0.0.255.255
```

## NHRP on a Multipoint Tunnel: Example

With multipoint tunnels, a single tunnel interface may be connected to multiple neighboring routers. Unlike point-to-point tunnels, a tunnel destination need not be configured. In fact, if configured, the tunnel destination must correspond to an IP multicast address. Broadcast or multicast packets to be sent over the tunnel interface can then be sent by sending the GRE packet to the multicast address configured as the tunnel destination.

Multipoint tunnels require that you configure a tunnel key. Otherwise, unexpected GRE traffic could easily be received by the tunnel interface. For simplicity, we recommend that the tunnel key correspond to the NHRP network identifier.

In the following example, routers A, B, C, and D all share an Ethernet segment. Minimal connectivity over the multipoint tunnel network is configured, thus creating a network that can be treated as a partially meshed NBMA network. Due to the static NHRP map entries, router A knows how to reach router B, router B knows how to reach router C, router C knows how to reach router D, and router D knows how to reach Router A.

When router A initially attempts to send an IP packet to router D, the packet is forwarded through routers B and C. The routers use NHRP to quickly learn the NBMA addresses of each other (in this case, IP addresses assigned to the underlying Ethernet network). The partially meshed tunnel network readily becomes fully meshed, at which point any of the routers can directly communicate over the tunnel network without their IP traffic requiring an intermediate hop.

The significant portions of the configurations for routers A, B, C, and D follow:

### Router A Configuration

```
interface tunnel 0
  no ip redirects
  ip address 11.0.0.1 255.0.0.0
  ip nhrp map 11.0.0.2 10.0.0.2
  ip nhrp network-id 1
  ip nhrp nhs 11.0.0.2
  tunnel source ethernet 0
  tunnel mode gre multipoint
  tunnel key 1

interface ethernet 0
  ip address 10.0.0.1 255.0.0.0
```

### Router B Configuration

```
interface tunnel 0
  no ip redirects
  ip address 11.0.0.2 255.0.0.0
  ip nhrp map 11.0.0.3 10.0.0.3
  ip nhrp network-id 1
  ip nhrp nhs 11.0.0.3
  tunnel source ethernet 0
  tunnel mode gre multipoint
  tunnel key 1

interface ethernet 0
  ip address 10.0.0.2 255.0.0.0
```

### Router C Configuration

```
interface tunnel 0
  no ip redirects
  ip address 11.0.0.3 255.0.0.0
  ip nhrp map 11.0.0.4 10.0.0.4
```

```

ip nhrp network-id 1
ip nhrp nhs 11.0.0.4
tunnel source ethernet 0
tunnel mode gre multipoint
tunnel key 1

interface ethernet 0
ip address 10.0.0.3 255.0.0.0

```

### Router D Configuration

```

interface tunnel 0
no ip redirects
ip address 11.0.0.4 255.0.0.0
ip nhrp map 11.0.0.1 10.0.0.1
ip nhrp network-id 1
ip nhrp nhs 11.0.0.1
tunnel source ethernet 0
tunnel mode gre multipoint
tunnel key 1

interface ethernet 0
ip address 10.0.0.4 255.0.0.0

```

## Show NHRP: Examples

The following is sample output from the **show ip nhrp** command:

```

Router# show ip nhrp

10.0.0.2 255.255.255.255, tunnel 100 created 0:00:43 expire 1:59:16

Type: dynamic Flags: authoritative

NBMA address: 10.1111.1111.1111.1111.1111.1111.1111.1111.1111.11

10.0.0.1 255.255.255.255, Tunnel0 created 0:10:03 expire 1:49:56

Type: static Flags: authoritative

NBMA address: 10.1.1.2

```

The fields in the sample display are as follows:

- The IP address and its network mask in the IP-to-NBMA address cache. The mask is always 255.255.255.255 because Cisco does not support aggregation of NBMA information through NHRP.
- The interface type and number and how long ago it was created (hours:minutes:seconds).
- The time in which the positive and negative authoritative NBMA address will expire (hours:minutes:seconds). This value is based on the **ip nhrp holdtime** command.
- Type of interface:
  - dynamic—NBMA address was obtained from the NHRP Request packet.
  - static—NBMA address was statically configured.
- Flags:

- authoritative—Indicates that the NHRP information was obtained from the Next Hop Server or router that maintains the NBMA-to-IP address mapping for a particular destination.
- implicit—Indicates that the information was learned from the source mapping information of an NHRP resolution request received by the local router, or from an NHRP resolution packet being forwarded through the local router.
- negative—For negative caching; indicates that the requested NBMA mapping could not be obtained.
- unique—Indicates that this NHRP mapping entry must be unique; it cannot be overwritten with a mapping entry that has the same IP address but a different NBMA address.
- registered—Indicates the NHRP mapping entry was created by an NHRP registration request.
- used—Indicates the NHRP mapping was used to forward data packets within the last 60 seconds.
- router—Indicates an NHRP mapping entry that is from a remote router that is providing access to a network or host behind the remote router.
- local—Indicates an NHRP mapping entry for networks local to this router for which this router has answered an NHRP resolution request.
- (no socket)—Indicates an NHRP mapping entry for which IPsec socket (for encryption) has not been triggered. These mapping entries are not used to forward data packets.
- nat—Indicates an NHRP mapping entry for which IPsec socket (for encryption) has not been triggered. These mapping entries are not used to forward data packets.
- NBMA address—Nonbroadcast multiaccess address. The address format is appropriate for the type of network being used (for example, GRE, Ethernet, SMDS, or multipoint tunnel)

The following is sample output from the **show ip nhrp traffic** command which displays NHRP traffic statistics:

```
Router# show ip nhrp traffic
Tunnel0
  request packets sent: 2
  request packets received: 4
  reply packets sent: 4
  reply packets received: 2
  register packets sent: 0
  register packets received: 0
  error packets sent: 0
  error packets received: 0
```

The fields shown in the sample display are as follows:

- Tunnel0—Interface type and number.
- request packets sent—Number of NHRP request packets originated from this station.
- request packets received—Number of NHRP request packets received by this station.
- reply packets sent—Number of NHRP reply packets originated from this station.
- reply packets received—Number of NHRP reply packets received by this station.
- register packets sent—Number of NHRP register packets originated from this station. Routers and access servers do not send register packets, so this value is 0.
- register packets received—Number of NHRP register packets received by this station. Routers or access servers do not send register packets, so this value is 0.
- error packets sent—Number of NHRP error packets originated by this station.
- error packets received—Number of NHRP error packets received by this station.

The following example shows output for a specific tunnel, tunnel7:

```
Router# show ip nhrp traffic interface tunnel7

Tunnel7: Max-send limit:100Pkts/10Sec, Usage:0%

Sent: Total 79

18 Resolution Request 10 Resolution Reply 42 Registration Request
0 Registration Reply 3 Purge Request 6 Purge Reply
0 Error Indication 0 Traffic Indication

Rcvd: Total 69

10 Resolution Request 15 Resolution Reply 0 Registration Request
36 Registration Reply 6 Purge Request 2 Purge Reply
0 Error Indication 0 Traffic Indication
```

NHRP holdtime = 600, NHRP registration timeout not set. NHRP registrations will be sent every 200 seconds so the time to detect that an NHS is down would range from 7 to 207 seconds with an average of 107 seconds.

```
Router# show ip nhrp nhs detail

Legend:
E=Expecting replies
R=Responding

Tunnel0:
10.0.0.1 E req-sent 14793 req-failed 1 repl-recv 14751 (00:25:07 ago)
10.0.0.2 req-sent 26 req-failed 9 repl-recv 0
Legend:
E=Expecting replies
R=Responding

Tunnel1:
10.0.1.1 RE req-sent 14765 req-failed 1 repl-recv 14763 (00:01:07 ago)

Pending Registration Requests:
```

Registration Request: Reqid 29507, Ret 64 NHS 10.0.0.1  
 Registration Request: Reqid 29511, Ret 64 NHS 10.0.0.2

10.0.0.1 is new (expecting replies) and is down.  
 10.0.0.2 is old (not expecting replies) and is assumed up.  
 10.0.1.1 is new (expecting replies) and is up.

## Additional References

The following sections provide references related to the configuring NHRP.

### Related Documents

| Related Topic   | Document Title   |
|---|--|
| The DMVPN feature allows users to better scale large and small IP Security (IPsec) Virtual Private Networks (VPNs) by combining generic routing encapsulation (GRE) tunnels, IPsec encryption, and Next Hop Resolution Protocol (NHRP).   | <a href="#">Dynamic Multipoint VPN (DMVPN)</a>                             |
| Routers in a Dynamic Multipoint VPN (DMVPN) network can use the Next Hop Resolution Protocol (NHRP) to discover the addresses of other routers and networks behind those routers that are connected to a DMVPN nonbroadcast multiaccess (NBMA) network. NHRP provides an ARP-like solution that alleviates NBMA network problems, such as hub failure, decreased reliability, and complex configurations. | <a href="#">Shortcut Switching Enhancements for NHRP in DMVPN Networks</a> |
| NHRP commands   | <a href="#">Cisco IOS IP Addressing Services Command Reference</a>         |

### RFCs

| RFC      | Title                                    |
|----------|--|
| RFC 2332 | NBMA Next Hop Resolution Protocol (NHRP) |

### Technical Assistance

| Description  | Link  |
|--|---|
| The Cisco Technical Support & Documentation website contains thousands of pages of searchable technical content, including links to products, technologies, solutions, technical tips, tools, and technical documentation. Registered Cisco.com users can log in from this page to access even more content. | <a href="http://www.cisco.com/techsupport">http://www.cisco.com/techsupport</a> |

# Feature Information for Configuring NHRP

Table 1 lists the release history for this feature.

Table 1 lists the features in this module and provides links to specific configuration information.

Not all commands may be available in your Cisco IOS software release. For release information about a specific command, see the command reference documentation.

Use Cisco Feature Navigator to find information about platform support and software image support. Cisco Feature Navigator enables you to determine which Cisco IOS and Catalyst OS software images support a specific software release, feature set, or platform. To access Cisco Feature Navigator, go to <http://www.cisco.com/go/cfn>. An account on Cisco.com is not required.



**Note**

Table 1 lists only the Cisco IOS software release that introduced support for a given feature in a given Cisco IOS software release train. Unless noted otherwise, subsequent releases of that Cisco IOS software release train also support that feature.

**Table 1** Feature Information for Configuring NHRP

| Feature Name                 | Releases                 | Feature Information   |
|------------------------------|--------------------------|---|
| Next Hop Resolution Protocol | Cisco IOS XE Release 2.1 | This feature was integrated on the Cisco ASR 1000 Series Routers. |

CCDE, CCENT, Cisco Eos, Cisco HealthPresence, the Cisco logo, Cisco Lumin, Cisco Nexus, Cisco StadiumVision, Cisco TelePresence, Cisco WebEx, DCE, and Welcome to the Human Network are trademarks; Changing the Way We Work, Live, Play, and Learn and Cisco Store are service marks; and Access Registrar, Aironet, AsyncOS, Bringing the Meeting To You, Catalyst, CCDA, CCDP, CCIE, CCIP, CCNA, CCNP, CCSP, CCVP, Cisco, the Cisco Certified Internetwork Expert logo, Cisco IOS, Cisco Press, Cisco Systems, Cisco Systems Capital, the Cisco Systems logo, Cisco Unity, Collaboration Without Limitation, EtherFast, EtherSwitch, Event Center, Fast Step, Follow Me Browsing, FormShare, GigaDrive, HomeLink, Internet Quotient, IOS, iPhone, iQuick Study, IronPort, the IronPort logo, LightStream, Linksys, MediaTone, MeetingPlace, MeetingPlace Chime Sound, MGX, Networkers, Networking Academy, Network Registrar, PCNow, PIX, PowerPanels, ProConnect, ScriptShare, SenderBase, SMARTnet, Spectrum Expert, StackWise, The Fastest Way to Increase Your Internet Quotient, TransPath, WebEx, and the WebEx logo are registered trademarks of Cisco Systems, Inc. and/or its affiliates in the United States and certain other countries.

All other trademarks mentioned in this document or website are the property of their respective owners. The use of the word partner does not imply a partnership relationship between Cisco and any other company. (0812R)

Any Internet Protocol (IP) addresses used in this document are not intended to be actual addresses. Any examples, command display output, and figures included in the document are shown for illustrative purposes only. Any use of actual IP addresses in illustrative content is unintentional and coincidental.

© 2008 Cisco Systems, Inc. All rights reserved.