



# Configuring ITU-T Y.1731 Fault Management Functions

---

**First Published: October 20, 2008**

**Last Updated: February 5, 2011**

The ITU-Y.1731 Fault Management Functions feature provides new functions for fault and performance management to serve the needs of service providers in large networks. These new functions extend Ethernet Alarm Indication Signal (ETH-AIS) and Ethernet Remote Defect Indication (ETH-RDI) to include fault detection, fault verification, and fault isolation for large Ethernet Metropolitan-Area Networks (MANs) and Wide-Area Networks (WANs).

## Finding Feature Information

Your software release may not support all the features documented in this module. For the latest feature information and caveats, see the release notes for your platform and software release. To find information about the features documented in this module, and to see a list of the releases in which each feature is supported, see the [“Feature Information for Configuring ITU-T Y.1731 Fault Management Functions” section on page 17](#).

Use Cisco Feature Navigator to find information about platform support and Cisco software image support. To access Cisco Feature Navigator, go to <http://www.cisco.com/go/cfn>. An account on Cisco.com is not required.

## Contents

- [Prerequisites for Configuring ITU-T Y.1731 Fault Management Functions, page 2](#)
- [Restrictions for Configuring ITU-T Y.1731 Fault Management Functions, page 2](#)
- [Information About Configuring ITU-T Y.1731 Fault Management Functions, page 3](#)
- [How to Configure ITU-T Y.1731 Fault Management Functions, page 8](#)
- [Configuration Examples for Configuring ITU-T Y.1731 Fault Management Functions, page 12](#)



---

**Americas Headquarters:**

**Cisco Systems, Inc., 170 West Tasman Drive, San Jose, CA 95134-1706 USA**

- [Additional References, page 15](#)
- [Feature Information for Configuring ITU-T Y.1731 Fault Management Functions, page 17](#)

## Prerequisites for Configuring ITU-T Y.1731 Fault Management Functions

### Business Requirements

- Network topology and network administration have been evaluated.
- Business and service policies have been established.
- A Server Maintenance End Point (SMEP) needs to support ETH-AIS function.
- Connectivity Fault Management (CFM) needs to be configured and enabled for Y.1731 Fault Management support.
- Maintenance Intermediate Point (MIP) configuration is required as AIS messages are only generated on the interface which has MIP configured.

## Restrictions for Configuring ITU-T Y.1731 Fault Management Functions

- Because of a port-ASIC hardware limitation, CFM cannot coexist with the Per VLAN Spanning Tree (PVST) protocol, and CFM cannot operate with the following line cards on the same system:
  - FI\_WS\_X6196\_RJ45
  - FI\_WS\_X6196\_RJ21
  - FI\_WS\_X6548\_RJ45
  - FI\_WS\_X6548\_RJ21
- CFM loopback messages are not confined within a maintenance domain according to their maintenance level. The impact of not having CFM loopback messages confined to their maintenance levels occurs at these levels:
  - Architecture—CFM layering is violated for loopback messages.
  - Deployment—A user may potentially misconfigure a network and have loopback messages succeed.
  - Security—A malicious device that recognizes devices' MAC addresses and levels may potentially explore a network topology that should be transparent.
- Routed interfaces are supported only in Cisco IOS Release 12.4(11)T.
- CFM is not fully supported on a Multiprotocol Label Switching (MPLS) Provider Edge (PE) device. There is no interaction between CFM and an Ethernet over MPLS (EoMPLS) pseudowire. A CFM packet can be transparently passed like regular data packets only via pseudowire, with the following restriction:

- For Policy Feature Card (PFC) based EoMPLS, which uses a Cisco Catalyst LAN card as the MPLS uplink port, a CFM packet can be transparently passed via an EoMPLS pseudowire like regular data packets. The EoMPLS endpoint interface, however, cannot be a Maintenance End Point (MEP) or an MIP, although a CFM MEP or MIP can be supported on regular Layer 2 switchport interfaces.
- CFM configuration is not supported on an EtherChannel in FastEthernet Channel (FEC) mode.
- The High Availability features, Non-Stop Forwarding and Stateful Switchover (NSF/SSO) Support, in CFM 802.1ag/1.0d and In Service Software Upgrade (ISSU) Support in CFM 802.1ag/1.0d are not supported on a Customer Edge (CE) device.
- The NSF/SSO Support in CFM 802.1ag/1.0d feature is not supported for the trace route and error databases because the Y.1731 Fault Management HA error database is synchronized between active and standby as both CFM HA and Y.1731 Fault Management were released in Cisco IOS Software Release 12.2SRD.

## Information About Configuring ITU-T Y.1731 Fault Management Functions

- [ETH-AIS General Overview, page 3](#)
- [ETH-AIS Transmission, Reception, and Processing Overview, page 4](#)
- [AIS Transmission, page 5](#)
- [AIS Reception, page 6](#)
- [ETH-RDI, page 7](#)
- [CCM Information, page 7](#)
- [CCM with ETH-RDI Reception, page 8](#)

### ETH-AIS General Overview

- When a MEP detects a connectivity fault at a specific level, it will multicast AIS in the direction away from the detected failure at the immediate client Maintenance Association (MA) level.
- AIS is generated by a MEP for each VLAN or server on the network because MEPs monitor the whole physical link. A MEP could be monitoring a VLAN, Ethernet Virtual Connection (EVC), or a SMEP where link up or link down and 802.3ah interworking are supported.
- AIS causes the receiving MEPs to suppress the traps so the Network Management System (NMS) does not receive an excessive number of redundant traps for a particular fault and also so that clients are asynchronously informed regarding faults.
- As AIS cannot determine which remote peer has lost connectivity in a multipoint scenario all peer MEPs enter AIS state and suppress alarms.

**Note**

Use of AIS is not recommended in networks that have independent restoration capability.

## ETH-AIS Transmission, Reception, and Processing Overview

ETH-AIS is used to suppress alarms following detection of defect conditions at the server layer or server sublayer. Transmission of frames with ETH-AIS information can be enabled or disabled on a MEP. Frames with ETH-AIS information can be issued at the client maintenance level by a MEP or SMEP upon detecting defect conditions. For example, the defect conditions may include those in the following sections:

- [Signal Fail Conditions When Ethernet Continuity Check Is Enabled, page 4](#)
- [AIS Condition When ETH-CC Is Disabled, page 5](#)



### Note

Due to independent restoration capabilities provided within Spanning Tree Protocol (STP) environments, ETH-AIS is not expected to be applied in STP environments but ETH-AIS transmission can be configured in STP environments.

For multipoint Ethernet connectivity, a MEP cannot determine the specific server layer or server sublayer that has encountered the defect conditions upon receiving a frame with ETH-AIS information, it also cannot determine the associated subset of its peer MEPs for which it should suppress alarms because the received ETH-AIS information does not contain that information. Therefore, upon reception of a frame with ETH-AIS information, the MEP will suppress alarms for all peer MEPs whether there is still connectivity or not. However, for a point-to-point Ethernet connection, a MEP has only a single peer MEP, so there is no ambiguity regarding the peer MEP for which it should suppress alarms when it receives the ETH-AIS information.

Only a MEP or an SMEP can be configured to issue frames with ETH-AIS information. Upon detecting a defect condition, the MEP can immediately start transmitting periodic frames with ETH-AIS information at a configured client maintenance level, which in Cisco IOS software is sent at the Maintenance Intermediate Point (MIP) level configured on the interface. A MEP continues to transmit frames with ETH-AIS information until the defect condition is removed. Upon receiving a frame with ETH-AIS information a MEP detects AIS condition and suppresses loss-of-continuity alarms associated with all its peer MEPs. A MEP can only resume loss-of-continuity alarm generation when the MEP exits the AIS condition.

## Signal Fail Conditions When Ethernet Continuity Check Is Enabled

### Mismerge Condition

A MEP detects mismerge when it receives a Continuity Check Message (CCM) frame with a correct maintenance level but incorrect maintenance ID that indicates that frames from a different service instance are merged with the service instance represented by the MEP's own maintenance ID.



### Note

In Cisco IOS Software mismerge condition will be a cross-connect error.

### Unexpected MEP Conditions

A MEP detects unexpected MEP conditions when it receives a CCM frame with a correct maintenance level, a correct maintenance ID, and an unexpected MEP ID that includes the MEP's own MEP ID. Determination of unexpected MEP ID is possible when the MEP maintains a list of its peer MEP IDs. A list of peer MEP IDs must be configured on each MEP during provisioning. This defect condition is most likely caused by misconfiguration.

**Note**

In Cisco IOS Software unexpected MEP conditions will be cross-check or configuration errors. A configuration error occurs when the Maintenance Point ID (MPID) received through CCM is the same as the MPID configured on the MEP.

- Unexpected maintenance level condition—A MEP detects unexpected maintenance level when it receives a CCM frame with the incorrect maintenance level.
- Unexpected period condition—A MEP detects unexpected period when it receives a CCM frame with a correct maintenance level, a correct MPID, and a correct MEP ID, but with a period field value different from the MEP's own CCM transmission period.
- Signal fail condition—Signal fail condition may be declared by the server layer termination function to notify the SMEP about a defect condition in the server layer. Signal fail conditions in Cisco IOS Software due to CCM are as follows:
  - Cross-connect error
  - Configuration error
  - Loop error
  - MEP unknown
  - MEP missing

## AIS Condition When ETH-CC Is Disabled

Signal fail conditions will cause AIS defect conditions for the MEP, resulting in the MEPs receiving an AIS frame.

## AIS Transmission

Upon detecting a defect condition a MEP will transmit frames to its peer MEPs in the opposite direction to the fault. The frequency of transmission of AIS frames is based on the AIS transmission period. The first AIS frame must always be transmitted immediately following the detection of a defect condition.

**Note**

An AIS transmission period of 1 second is recommended.

The client layer or client sublayer may consist of multiple MAs that should be notified to suppress alarms resulting from defect conditions detected by the server layer or server sublayer MEP. Upon detecting the signal fail condition the MEP will send AIS frames to each of the client layer or sublayer MAs. The first AIS frame for all client layer or sublayer MAs must be transmitted within 1 second of detection of the defect condition.

**Note**

To support ETH-AIS across all 4094 VLANs that CFM supports another AIS transmission period of 1 minute is also supported.

## AIS Reception

Upon receiving an AIS frame, a MEP examines it to ensure that the MA level corresponds to its own MA level. The period field indicates the period at which the AIS frames can be expected. Following detection of AIS defect condition, if no AIS frames are received within an interval of 3.5 times the transmission period, the MEP clears the AIS defect condition.

## Dying Gasp Generation

Dying Gasp is an unrecoverable condition. This type of condition is vendor specific. A notification about the condition may be sent immediately and continuously.

Dying Gasp is generated in following conditions:

- Link down caused by administration down.
- Power failure.
- Reload.
- Administratively disabling 802.3ah.

**Note**

---

Administratively disabling 802.3ah is not traffic disrupting and should not generate AIS. But in the absence of a reason field when interworking with routers other than Cisco routers, disabling will always generate AIS.

---

## AIS Interworking

The following conditions impact SMEP AIS conditions:

- Link down events cause the SMEP to enter AIS condition and generate AIS frames for all services by default at the immediate client MA level.
- Link up events cause the SMEP to exit AIS condition and stop generating AIS frames.
- Local fault detection due to Dying gasp, link fault and critical 802.3ah Remote Fault Indication (RFI). When 802.3ah is reestablished the SMEP exits AIS condition and stops generating AIS frames.
- Local fault detection due to crossing of high threshold whose configurable action is error disabling the interface.
- RFI received from Dying gasp, link fault or critical event.

If the detected fault is due to Dying gasp, the link will go down in both directions creating AIS and RDI frame flow as shown in [Figure 1](#).

Figure 1 AIS/RDI Frame Flow with Fault on Both rx and tx

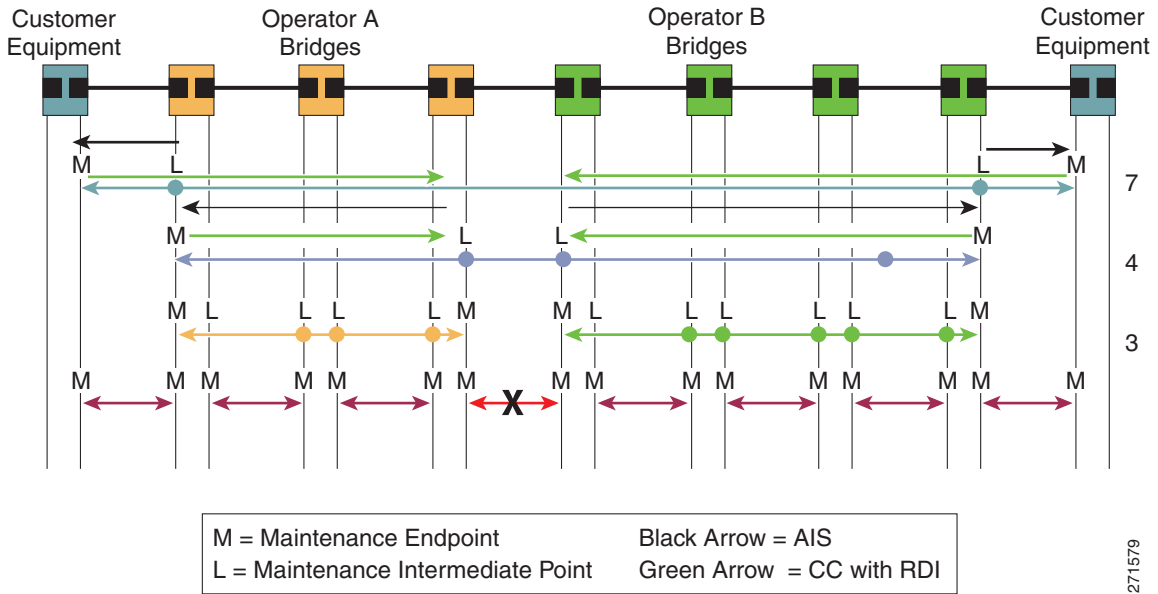

## ETH-RDI

ETH-RDI can be used by a MEP to communicate to its peer MEPs that a defect condition has been encountered. ETH-RDI is used only when Ethernet OAM Continuity Check (ETH-CC) transmission is enabled.

ETH-RDI has the following two applications:

- Single-ended fault management—The receiving MEP detects a RDI defect condition, which gets correlated with other defect conditions in this MEP and may become a fault cause. The absence of received ETH-RDI information in a single MEP indicates the absence of defects in the entire MA.
- Contribution to far-end performance monitoring—It reflects that there was a defect condition in the far end, which is used as an input to the performance monitoring process.

A MEP that is in a defect condition transmits frames with ETH-RDI information. Upon receiving frames with ETH-RDI information, a MEP determines that its peer MEP has encountered a defect condition. However, for multipoint Ethernet connectivity, a MEP, upon receiving frames with ETH-RDI information, cannot determine the associated subset of its peer MEPs with which the MEP transmitting RDI information encounters defect conditions, as the transmitting MEP itself does not always have that information.

## CCM Information

CFM continuity check messages (CCMs) are messages exchanged among MEPs. They allow MEPs to discover other MEPs within a domain and allow MIPs to discover MEPs.

CFM CCMs have the following characteristics:

- Transmitted at a configurable periodic interval by MEPs. The interval can be from 10 seconds to 65535 seconds, the default is 30.
- Contain a configurable hold time value to indicate to the receiver the validity of the message. The default hold time value is 3.5 times the transmit interval.
- Catalogued by MIPs at the same maintenance level.
- Terminated by remote MEPs at the same maintenance level.
- Unidirectional and do not solicit a response.
- Carries the status of the port on which the MEP is configured.

## CCM with ETH-RDI Reception

Upon receiving a CCM frame, a MEP examines it to ensure that its MA Level corresponds to its configured MA Level and detects RDI condition if the RDI field is set. For a point-to-point Ethernet connection, a MEP can clear the RDI condition when it receives the first CCM frame from its peer MEP with the RDI field cleared. For multipoint Ethernet connectivity, a MEP can clear the RDI condition when it receives the CCM frames from its entire list of peer MEPs with the RDI fields cleared.

## How to Configure ITU-T Y.1731 Fault Management Functions

Y.1731 fault management enhancements consist of ETH-AIS and ETH-RDI. Both enhancements are enabled by default when CFM is configured but each is enabled by a separate command during CFM configuration.

- ETH-AIS is enabled by default by the **ethernet cfm enable** command.
- ETH-RDI is enabled by default by the **ethernet cfm cc enable level** command.

Perform this task to change the default configuration.

### SUMMARY STEPS

1. **enable**
2. **configure terminal**
3. **ethernet cfm ais link-status global**
4. **level** *level-id*  
or  
**disable**
5. **period** *value*
6. **exit**
7. **ethernet cfm ais domain** *domain-id* [**vlan** *vlan-id* | **evc** *evc-name*]
8. **disable**
9. **period** *value*
10. **level** *level-id*

11. **expiry-threshold** *value*
12. **no suppress-alarm**
13. **exit**
14. **ethernet cfm cc enable level** {*any* | *level-id* | *,level-id* | *level-id-level-id* | *,level-id-level-id*} **vlan** {*any* | *vlan-id* | *,vlan-id* | *vlan-id-vlan-id* | *,vlan-id-vlan-id*}
15. **ethernet cfm cc level** {*any* | *level-id* | *level-id-level-id* | [*,level-id-level-id*]} **vlan** {*vlan-id* | *any* | *vlan-id-vlan-id* | [*,vlan-id-vlan-id*]} [**interval** *seconds*] [**loss-threshold** *num-msgs*]
16. **exit**

**DETAILED STEPS**

	<b>Command or Action</b>	<b>Purpose</b>
<b>Step 1</b>	<b>enable</b>  <b>Example:</b> Router> enable	Enables privileged EXEC mode.  • Enter your password if prompted.
<b>Step 2</b>	<b>configure terminal</b>  <b>Example:</b> Router# configure terminal	Enters global configuration mode.
<b>Step 3</b>	<b>ethernet cfm ais link-status global</b>  <b>Example:</b> Router(config)# ethernet cfm ais link-status global	Configures AIS specific commands for SMEP and enters config-ais-link-cfm mode.
<b>Step 4</b>	<b>level</b> <i>level-id</i>  or <b>disable</b>  <b>Example:</b> Router(config-ais-link-cfm)# level 3  or Router(config-ais-link-cfm)# disable	Configures the maintenance level to send AIS frames transmitted by the SMEP.  or Disables ETH-AIS generation.
<b>Step 5</b>	<b>period</b> <i>value</i>  <b>Example:</b> Router(config-ais-link-cfm)# period 1	Configures the SMEP’s specific AIS transmission period interval.
<b>Step 6</b>	<b>exit</b>  <b>Example:</b> Router(config-ais-link-cfm)# exit	Returns the CLI to global configuration mode.

	Command or Action	Purpose
Step 7	<p><b>ethernet cfm ais domain</b> <i>domain-id</i> [<b>vlan</b> <i>vlan-id</i>   <b>evc</b> <i>evc-name</i>]</p> <p><b>Example:</b>  Router(config)# ethernet cfm ais domain PROVIDER vlan 44</p> <p>or</p> Router(config)# ethernet cfm ais domain XXX evc test	<p>Defines a CFM maintenance domain named PROVIDER on VLAN 44 and puts the command in config-ais-mep-cfm submode to configure parameters for all local MEPs belonging to that MA.</p> <p>or</p> <p>Defines a CFM maintenance domain named XXX on evc test and puts the command in config-ais-mep-cfm submode to configure parameters for all local MEPs belonging to that MA.</p>
Step 8	<p><b>disable</b></p> <p><b>Example:</b>  Router(config-ais-mep-cfm)# disable</p>	Disables AIS transmission from 802.03ah.
Step 9	<p><b>period</b> <i>value</i></p> <p><b>Example:</b>  Router(config-ais-mep-cfm)# period 1</p>	Configures the SMEP specific AIS transmission period interval.
Step 10	<p><b>level</b> <i>level-id</i></p> <p><b>Example:</b>  Router(config-ais-mep-cfm)#level 4</p>	Configures the maintenance level to send AIS frames transmitted by the MEP.
Step 11	<p><b>expiry-threshold</b> <i>value</i></p> <p><b>Example:</b>  Router(config-ais-mep-cfm)#expiry-threshold 20</p>	Sets the expiry threshold parameter for the MA.
Step 12	<p><b>no suppress-alarm</b></p> <p><b>Example:</b>  Router(config-ais-mep-cfm)#no suppress-alarm</p>	Overrides suppression of redundant alarm.
Step 13	<p><b>exit</b></p> <p><b>Example:</b>  Router(config-ais-mep-cfm)# exit</p>	Returns the command to global configuration mode.
Step 14	<p><b>ethernet cfm cc enable level</b> {<b>any</b>   <i>level-id</i>   <i>,level-id</i>   <i>level-id-level-id</i>   <i>,level-id-level-id</i>} <b>vlan</b> {<b>any</b>   <i>vlan-id</i>   <i>,vlan-id</i>   <i>vlan-id-vlan-id</i>   <i>,vlan-id-vlan-id</i>}</p> <p><b>Example:</b>  Router(config)# ethernet cfm cc enable level 2 vlan 100</p>	Globally enables transmission of CCMs at level 2 on VLAN 100 and enables the sending of traps between MEPs.

	Command or Action	Purpose
Step 15	<pre> <b>ethernet cfm cc level</b> {<b>any</b>   <i>level-id</i>   <i>level-id-level-id</i>   [,<i>level-id-level-id</i>]} <b>vlan</b> {<i>vlan-id</i>   <b>any</b>   <i>vlan-id-vlan-id</i>   [,<i>vlan-id-vlan-id</i>]} [<b>interval</b> <i>seconds</i>] [<b>loss-threshold</b> <i>num_msgs</i>] </pre> <p><b>Example:</b>  Router(config)# ethernet cfm cc level any vlan  any interval 20 loss-threshold 3</p>	Sets the following parameters for CCMs: <ul style="list-style-type: none"> <li>• All maintenance levels are to be configured.</li> <li>• All VLANs are to be configured.</li> <li>• The time between CCM transmissions is 20 seconds.</li> <li>• The maximum number of CCMs that can be missed before a MEP is declared down is 3.</li> </ul>
Step 16	<pre> <b>exit</b> </pre> <p><b>Example:</b>  Router(config)# exit</p>	Returns the command to privileged EXEC mode.

## SUMMARY STEPS

1. **enable**
2. **configure terminal**
3. **interface** *type number*
4. **ethernet cfm ais link-status**  
or  
**no ethernet cfm ais link-status**
5. **ethernet cfm ais link-status period** *value*
6. **ethernet cfm ais link-status level** *level-id*
7. **exit**

## DETAILED STEPS

	Command or Action	Purpose
Step 1	<pre> <b>enable</b> </pre> <p><b>Example:</b>  Router&gt; enable</p>	Enables privileged EXEC mode. <ul style="list-style-type: none"> <li>• Enter your password if prompted.</li> </ul>
Step 2	<pre> <b>configure terminal</b> </pre> <p><b>Example:</b>  Router# configure terminal</p>	Enters global configuration mode.
Step 3	<pre> <b>interface</b> <i>type number</i> </pre> <p><b>Example:</b>  Router(config)# interface GigabitEthernet0/1</p>	Configures an interface type and enters interface configuration mode.

	Command or Action	Purpose
Step 4	<pre> <b>ethernet cfm ais link-status</b>  or  <b>no ethernet cfm ais link-status</b>  <b>Example:</b> Router(config-if)# ethernet cfm ais link-status  or  Router(config-if)# no ethernet cfm ais link-status </pre>	<p>Enables AIS generation from SMEP on interface.</p> <p>or</p> <p>Disables AIS generation on the interface.</p>
Step 5	<pre> <b>ethernet cfm ais link-status period</b> <i>value</i>  <b>Example:</b> Router(config-if)# ethernet cfm ais link-status period 60 </pre>	<p>Sets the AIS transmission period generated by the SMEP on the interface.</p>
Step 6	<pre> <b>ethernet cfm ais link-status level</b> <i>level-id</i>  <b>Example:</b> Router(config-if)# ethernet cfm ais link-status level 4 </pre>	<p>Sets the maintenance level to send AIS frames transmitted by the SMEP on the interface.</p>
Step 7	<pre> <b>exit</b>  <b>Example:</b> Router(config-if)# exit </pre>	<p>Returns the CLI to global configuration mode.</p>

## Configuration Examples for Configuring ITU-T Y.1731 Fault Management Functions

- [Example: Enabling Ethernet CFM on an Interface, page 12](#)
- [Examples: show ethernet cfm Command Output, page 13](#)
- [Example: Syslog AIS Message with Interface Name, page 14](#)

### Example: Enabling Ethernet CFM on an Interface

```

!
ethernet cfm domain ServiceProvider level 4
mep archive-hold-time 60
service MetroCustomer1 vlan 100
!
ethernet cfm domain OperatorA level 1
mep archive-hold-time 65
service MetroCustomer1OpA vlan 100
!
ethernet cfm enable
ethernet cfm traceroute cache
ethernet cfm traceroute cache size 200

```

```

ethernet cfm traceroute cache hold-time 60
!
interface gigabitethernet3/0
ethernet cfm mip level 1
!
interface gigabitethernet4/0
ethernet cfm mip level 4
ethernet cfm mep level 1 mpid 102 vlan 100
!
ethernet cfm cc enable level 1 vlan 100
ethernet cfm cc level any vlan any interval 20 loss-threshold 3

```

## Examples: show ethernet cfm Command Output

```
Router# show ethernet cfm maintenance-points local detail
```

```

MEP Settings:
-----
MPID: 2101
DomainName: PROVIDER_DOMAIN
Level: 4
Direction: I
Vlan: 101
Interface: Et0/1
CC-Status: Enabled
MAC: aabb.cc03.8410
Defect Condition: AIS
presentRDI: TRUE
AIS-Status: Enabled
AIS Period: 1000(ms)
AIS Expiry Threshold: 3.5
Level to transmit AIS: Default
Suppress Alarm configuration: Enabled
Suppressing Alarms: Yes

```

```
Router# show ethernet cfm smep interface
```

```
Ethernet IEEE 802.3
```

```
Router# show ethernet cfm smep
```

```

SMEP Settings:
-----
Interface: Ethernet0/0
AIS-Status: Enabled
AIS Period: 60000 (ms)
Level to transmit AIS: 4
Defect Condition: No Defect

```

```
Router# show ethernet cfm error
```

Level	Vlan	MPID	Remote MAC	Reason	Service ID
5	102	-	aabb.cc00.ca10	Receive AIS	service test

```
Router# show ethernet cfm maintenance-points remote detail mpid 66
```

```

MAC Address: aabb.cc00.ca10
Domain/Level: PROVIDER_DOMAIN/4
EVC: test
MPID: 66 (Can ping/traceroute)
Incoming Port(s): Ethernet0/2

```

```
CC Lifetime(sec): 75
Age of Last CC Message(sec): 8
Receive RDI: TRUE
Frame Loss: 0%
CC Packet Statistics: 2/0 (Received/Error)
R1#MAC Address: aabb.cc00.ca10
Domain/Level: PROVIDER_DOMAIN/4
EVC: test
MPID: 66 (Can ping/traceroute)
Incoming Port(s): Ethernet0/2
CC Lifetime(sec): 75
Age of Last CC Message(sec): 8
Receive RDI: TRUE
Frame Loss: 0%
CC Packet Statistics: 2/0 (Received/Error)
```

## Example: Syslog AIS Message with Interface Name

```
00:05:39: %ETHER_CFM-6-ENTER_AIS: local mep with mpid 101 level 4 id 7 dir I Interface
Ethernet0/0 enters AIS defect condition

00:05:39: %ETHER_CFM-6-EXIT_AIS: local mep with mpid 101 level 4 id 7 dir I Interface
Ethernet0/0 exitec AIS defect condition

00:05:39: %ETHER_CFM-6-ENTER_AIS_INT: Interface Ethernet0/0 enters AIS defect condition
for outward direction

00:05:39: %ETHER_CFM-6-EXIT_AIS_INT: Interface Ethernet0/0 exited AIS defect condition for
outward direction
```

# Additional References

## Related Documents

Related Topic	Document Title
Ethernet CFM	<i><a href="#">Configuring Ethernet Connectivity Fault Management in a Service Provider Network</a></i>
Using OAM	<i><a href="#">Using Ethernet Operations, Administration, and Maintenance</a></i>
Carrier Ethernet commands: complete command syntax, command mode, command history, defaults, usage guidelines, and examples	<i><a href="#">Cisco IOS Carrier Ethernet Command Reference</a></i>
Cisco IOS commands: master list of commands with complete command syntax, command mode, command history, defaults, usage guidelines, and examples	<i><a href="#">Cisco IOS Master Command List, All Releases</a></i>

## Standards

Standard	Title
ITU-T	<i><a href="#">ITU-T Y.1731 OAM Mechanisms for Ethernet-Based Networks</a></i>

## MIBs

MIB	MIBs Link
No new or modified MIBs are supported by this feature, and support for existing MIBs has not been modified by this feature.	To locate and download MIBs for selected platforms, Cisco software releases, and feature sets, use Cisco MIB Locator found at the following URL: <a href="http://www.cisco.com/go/mibs">http://www.cisco.com/go/mibs</a>

## RFCs

RFC	Title
No new or modified RFCs are supported by this feature, and support for existing RFCs has not been modified.	—

## Technical Assistance

Description	Link
<p>The Cisco Support and Documentation website provides online resources to download documentation, software, and tools. Use these resources to install and configure the software and to troubleshoot and resolve technical issues with Cisco products and technologies. Access to most tools on the Cisco Support and Documentation website requires a Cisco.com user ID and password.</p>	<p><a href="http://www.cisco.com/cisco/web/support/index.html">http://www.cisco.com/cisco/web/support/index.html</a></p>

# Feature Information for Configuring ITU-T Y.1731 Fault Management Functions

Table 1 lists the release history for this feature.

Use Cisco Feature Navigator to find information about platform support and software image support. Cisco Feature Navigator enables you to determine which software images support a specific software release, feature set, or platform. To access Cisco Feature Navigator, go to <http://www.cisco.com/go/cfn>. An account on Cisco.com is not required.



## Note

Table 1 lists only the software release that introduced support for a given feature in a given software release train. Unless noted otherwise, subsequent releases of that software release train also support that feature.

**Table 1** Feature Information for Configuring ITU-T Y.1731 Fault Management Functions

Feature Name	Releases	Feature Information
Configuring ITU-T Y.1731 Fault Management Functions	12.2(33)SRD	<p>The ITU-Y.1731 Fault Management Functions feature provides new functions for fault and performance management to serve the needs of service providers in large networks. These new functions extend Ethernet Alarm Indication Signal (ETH-AIS) and Ethernet Remote Defect Indication (ETH-RDI) to include fault detection, fault verification, and fault isolation for large Ethernet MANs and WANs.</p> <p>The following sections provide information about this feature:</p> <ul style="list-style-type: none"> <li>• <a href="#">Information About Configuring ITU-T Y.1731 Fault Management Functions, page 3</a></li> <li>• <a href="#">How to Configure ITU-T Y.1731 Fault Management Functions, page 8</a></li> <li>• <a href="#">Configuration Examples for Configuring ITU-T Y.1731 Fault Management Functions, page 12</a></li> </ul> <p>The following commands were introduced or modified:  <b>clear ethernet cfm ais domain, clear ethernet cfm ais link-status interface, ethernet cfm ais domain, ethernet cfm ais link-status global, ethernet cfm logging, show ethernet cfm error, show ethernet cfm maintenance-points local detail, show ethernet cfm maintenance-points remote detail, show ethernet cfm smep interface.</b></p>

Cisco and the Cisco Logo are trademarks of Cisco Systems, Inc. and/or its affiliates in the U.S. and other countries. A listing of Cisco's trademarks can be found at [www.cisco.com/go/trademarks](http://www.cisco.com/go/trademarks). Third party trademarks mentioned are the property of their respective owners. The use of the word partner does not imply a partnership relationship between Cisco and any other company. (1005R)

Any Internet Protocol (IP) addresses used in this document are not intended to be actual addresses. Any examples, command display output, and figures included in the document are shown for illustrative purposes only. Any use of actual IP addresses in illustrative content is unintentional and coincidental.

© 2008–2011 Cisco Systems, Inc. All rights reserved.