



# MPLS Enhancements to Interfaces MIB

---

**First Published: March 15, 2004**

**Last Updated: June 29, 2007**

This feature describes the Multiprotocol Label Switching (MPLS) enhancements to the existing interfaces Management Information Base (MIB) (RFC 2233) to support an MPLS layer. This layer provides counters and statistics specifically for MPLS.

## History for MPLS Enhancements to Interfaces MIB Feature

Release	Modification
12.0(23)S	This feature was introduced.
12.3(8)T	This feature was integrated into Cisco IOS Release 12.3(8)T.
12.2(33)SRA	This feature was integrated into Cisco IOS Release 12.2(33)SRA.
12.2(33)SXH	This feature was integrated into Cisco IOS Release 12.2(33)SXH.

## Finding Support Information for Platforms and Cisco IOS and Catalyst OS Software Images

Use Cisco Feature Navigator to find information about platform support and Cisco IOS and Catalyst OS software image support. To access Cisco Feature Navigator, go to <http://www.cisco.com/go/cfn>. An account on Cisco.com is not required.

## Contents

- [Prerequisites for MPLS Enhancements to Interfaces MIB, page 2](#)
- [Restrictions for MPLS Enhancements to Interfaces MIB, page 2](#)
- [Information About MPLS Enhancements to Interfaces MIB, page 3](#)
- [Configuration Examples for the MPLS Enhancements to Interfaces MIB, page 10](#)
- [Additional References, page 11](#)
- [Command Reference, page 12](#)
- [Glossary, page 16](#)



---

**Americas Headquarters:**  
**Cisco Systems, Inc., 170 West Tasman Drive, San Jose, CA 95134-1706 USA**

© 2004–2007 Cisco Systems, Inc. All rights reserved.

## Prerequisites for MPLS Enhancements to Interfaces MIB

- SNMP installed and enabled on the label switching routers (LSRs)
- MPLS enabled on the LSRs
- MPLS IP enabled on an interface or an MPLS traffic engineering (TE) tunnel enabled on an interface

## Restrictions for MPLS Enhancements to Interfaces MIB

- Link up and link down traps for the MPLS layer are not supported in this release.
- Write capability using the SNMP SET command is not supported for the MPLS layer in this release.
- Some counters, including discard and multicast, increment on the underlying physical layer; therefore, they equal 0 because they never reach the MPLS layer.
- Starting in Cisco IOS Release 12.4, the high-capacity counters for the MPLS layer interfaces of the Interfaces MIB contain 64 bits of counter data. In previous releases, the high capacity counters displayed 32 bits of counter data.

The following MIB objects are affected:

- ifHCInOctets
- ifHCOctets
- ifHCInUcastPkts
- ifHCOctetsUcastPkts

When the 64-bit values are less than the value of 232, the 32-bit and 64-bit values are identical.

After the counter increases to more than 232, the counters are different; the 64-bit value is computed by the following formula:

$$X * (232) + Y$$

where:

- X is the number of times the 32-bit counter has rolled.
- Y is the residual value of the counter after the roll occurred. The Y value equals the 32-bit value.

When the high-capacity counter values are compared to their 32-bit values, there is a period of time that the counter values are not equal. The 64-bit values lag behind the 32-bit values when the counters poll the 32-bit hardware counters and computing the correct counter value. During the polling and computation interval, the following high-capacity counter values counters might be inconsistent.

- ifInOctets
- ifOutOctets
- ifInUcastPkts
- ifOutUcastPkts

The inconsistent values can occur if traffic is constantly flowing over an interface and a MIB walk is performed. The 32-bit value is correct at that moment. The 64-bit value lags slightly behind, because of the polling computations needed to generate it. Once traffic stops flowing over the interface, and a polling period has passed, the two counters are identical and correct.

The lag time depends on the following factors:

- The polling interval used by the Interfaces MIB. The less time the polling interval takes, the more accurate the value is.
- The size of the Interfaces MIB. A large MIB takes a long time to walk and might affect the values found at that instant.
- The amount of computations needed to generate the 64-bit value. The number of MPLS-enabled interfaces increases the number of 64-bit counter values that need to be computed.

## Information About MPLS Enhancements to Interfaces MIB

To configure the MPLS Enhancements to Interfaces MIB, you need to understand the following concepts:

- [Feature Design of the MPLS Enhancements to Interfaces MIB, page 3](#)
- [Scalar Objects, page 5](#)
- [Stacking Relationships for MPLS Layer Interfaces, page 5](#)
- [Stacking Relationships for Traffic Engineering Tunnels, page 6](#)
- [MPLS Label Switching Router MIB Enhancements, page 7](#)
- [Benefits of the MPLS Enhancements to Interfaces MIB, page 8](#)

## Feature Design of the MPLS Enhancements to Interfaces MIB

The Interfaces MIB (IF MIB) provides a Simple Network Management Protocol (SNMP) based method for managing interfaces. Each entry in the IF MIB establishes indexing, statistics, and stacking relationships among underlying physical interfaces, subinterfaces, and Layer 2 protocols that exist within Cisco IOS.

The enhancements add an MPLS layer to the IF MIB as a Layer 2 protocol to provide statistics for traffic encapsulated as MPLS on an interface. In this new structure, MPLS-specific data, such as MPLS-encapsulated traffic counters and the MPLS maximum transmission unit (MTU), resides on top of the underlying physical or virtual interface to allow separation from non-MPLS data.

The enhancements also allow you to view indexing, statistics, and stacking relationships using the `ifStackTable`. MPLS layer interfaces are stacked above the underlying physical or virtual interface that is actually forwarding the MPLS traffic. MPLS traffic engineering tunnels are then stacked above those MPLS layers.

The IF MIB supports several types of interfaces. A virtual interface that provides protocol statistics for MPLS-encapsulated traffic has been added. This new interface is stacked above real Cisco IOS interfaces or subinterfaces, such as Ethernet (et0) or Asynchronous Transfer Mode (ATM) (at1/1.1).

Cisco IOS creates a corresponding MPLS layer above each interface capable of supporting MPLS when the MPLS encapsulation is enabled by issuing the interface configuration command **mpls ip**.

You can also create the interface layer if you enable MPLS traffic engineering (TE) by using the interface command **mpls traffic-eng tunnels**.

**Note**

You must also issue these commands in global configuration mode for MPLS IP and/or MPLS TE to be enabled.

An IF MIB entry is created when you enable either MPLS IP and/or MPLS TE tunnels on an interface; the entry is removed when you disable both MPLS IP and MPLS TE.

## ifStackTable Objects

Table 1 lists the ifStackTable objects and their descriptions.

**Table 1** *ifStackTable Objects and Definitions*

Object	Definition
ifStackHigherLayer	The value of ifIndex corresponding to the higher sublayer of the relationship; that is, the sublayer that runs on top of the sublayer identified by the corresponding instance of the ifStackLowerLayer.  <b>Note</b> Index objects are not accessible in a MIB walk. This value is part of the object identifier (OID) for every object in the ifStackTable.
ifStackLowerLayer	The value of ifIndex corresponding to the lower sublayer of the relationship; that is, the sublayer that runs below the sublayer identified by the corresponding instance of the ifStackHigherLayer.  <b>Note</b> Index objects are not accessible in a MIB walk. This value is part of the object identifier (OID) for every object in the ifStackTable.
ifStackStatus	Used to create and delete rows in the ifStackTable; status is always active(1) for MPLS.

## ifRcvAddressTable Objects

Table 2 lists the ifRcvAddressTable objects and their descriptions.

**Note**

Entries for the MPLS layer do not appear in the ifRcvAddressTable.

**Table 2** *ifRcvAddressTable Objects and Descriptions*

Object	Definition
ifRcvAddressAddress	An address for which the system accepts packets and frames on this entry's interface.  <b>Note</b> Index objects are not accessible in a MIB walk. This value is part of the object identifier (OID) for every object in the ifRcvAddressTable.

**Table 2** *ifRcvAddressTable Objects and Descriptions (continued)*

Object	Definition
ifRcvAddressStatus	Used to create and delete rows in the ifRcvAddressTable.
ifRcvAddressType	Type of storage used for each entry in the ifRcvAddressTable.

## Scalar Objects

The IF MIB supports the following scalar objects:

- **ifStackLastChange**—The value of sysUpTime at the time of the last change of the entire interface stack. A change of the interface stack is defined to be any creation, deletion, or change in value of any instance of ifStackStatus. If the interface stack has been unchanged since the last re-initialization of the local network management subsystem, then this object contains a zero value.
- **ifTableLastChange**—The value of sysUpTime at the time of the last creation or deletion of an entry in the ifTable. If the number of entries has been unchanged since the last reinitialization of the local network management subsystem, then this object contains a zero value.

## Stacking Relationships for MPLS Layer Interfaces

The ifStackTable within the IF MIB provides a conceptual stacking relationship between the interfaces and subinterfaces represented as entries in the ifTable.

The ifStackTable is indexed like a linked list. Each entry shows a relationship between two interfaces providing the ifIndexes of the upper and the lower interface. The entries chain together to show the entire stacking relationship. Each entry links with one another until the stack terminates with an ifIndex of 0 at the highest and lowest ends of the stack. For example, in [Figure 1](#), the indexes .10.5 show that ifIndex 10 is stacked upon ifIndex 5. There are 0 entries at the highest and lowest ends of the stack; in [Figure 1](#), the indexes .0.15 and 72.0 are the highest and lowest ends of the stack, respectively.

**Figure 1** Sample ATM Stacking Relationship in the ifStackTable

Table 3 describes the indexing of the ifStackTable for the layer relationships shown in Figure 1.

**Note**

The order of the entries in Table 3 may not be the same as that seen in the MIB walk, which has to follow SNMP ordering rules.

**Table 3** Layer Relationships

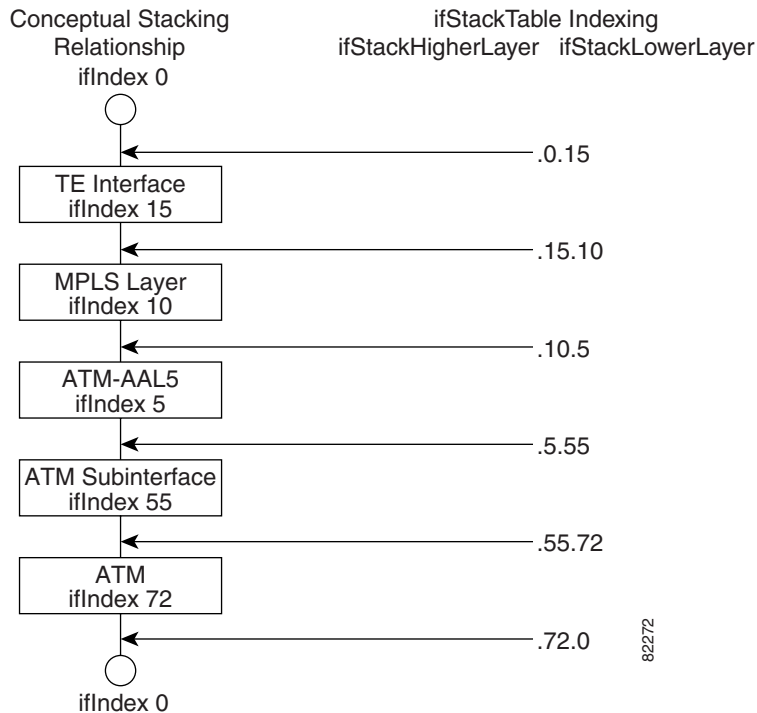
Layer Relationship (in Descending Order)	ifStackHigherLayer/ifStackLowerLayer
TE interface as top layer	.0.15
TE interface stacked upon MPLS layer	.15.10
MPLS layer stacked upon ATM-AAL5	.10.5
ATM-AAL5 layer stacked upon ATM subinterface	.5.55
ATM subinterface stacked upon ATM	.55.72
ATM as bottom layer	.72.0

## Stacking Relationships for Traffic Engineering Tunnels

MPLS TE tunnels are represented in Cisco IOS and the IF MIB as virtual interfaces. When properly signaled, TE tunnels pass traffic through MPLS over a physical interface. This process dictates that a TE tunnel is to be stacked on an MPLS layer that is stacked on an underlying interface.

TE tunnels can also change paths in response to different error or network conditions. These changes are instigated by using the RSVP-TE signaling protocol. When a change occurs, a tunnel can switch to a different MPLS interface. If no signaling path exists, no paths will be chosen and thus no MPLS interface will be used.

Because a TE tunnel is represented as an IF MIB ifTable entry, the ifStackTable also contains an entry corresponding to the TE tunnel. If the TE tunnel is successfully signaled, the ifStackTable also contains a link between the tunnel interface as well as one MPLS interface. Note that because it is possible for a TE tunnel to not have a corresponding signaled path, it is thus possible for a TE tunnel's ifStackTable entry to not have a corresponding lower layer. In this case, the lower layer variable contains the value of 0.

Figure 2 shows a TE tunnel before (left) and after (right) being rerouted and the affect on the ifStackTable. When ifIndex 2 fails, the TE tunnel is rerouted through ifIndex 1, the 15.2 entry is removed from the ifStackTable, and the 15.1 entry is added.

**Figure 2** Sample TE Tunnel Stacking Relationship

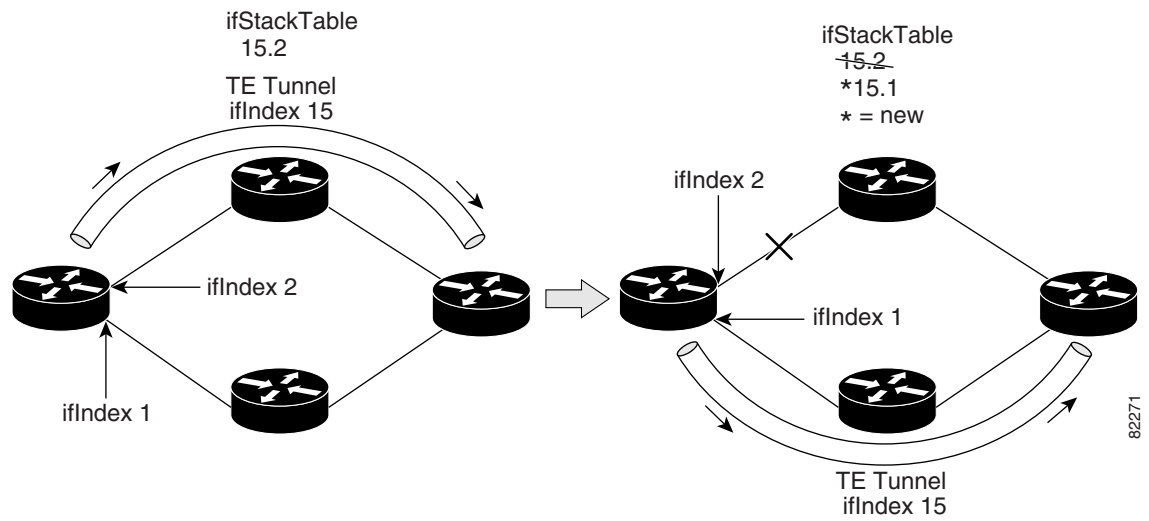

## MPLS Label Switching Router MIB Enhancements

All of the ifIndex references in the MPLS-LSR-MIB tables have changed from the ifIndex of the underlying physical or virtual interface to the ifIndex of the MPLS layer.

Table 4 shows the specific changes.

**Table 4** MPLS-LSR-MIB ifIndex Objects Enhanced

Table	ifIndex
MPLS interface configuration table (mplsInterfaceConfTable)	mplsInterfaceConfIndex
MPLS in-segment table (mplsInSegmentTable)	mplsInSegmentIfIndex
MPLS cross-connect table (mplsXCTable)	mplsInSegmentIfIndex
MPLS out-segment table (mplsOutSegmentTable)	mplsOutSegmentIfIndex

The following objects from the `mplsInterfaceConfTable` are affected:

- `mplsInterfaceOutPackets`—Count only MPLS-encapsulated packets
- `mplsInterfaceInPackets`—Count only MPLS-encapsulated packets

## Benefits of the MPLS Enhancements to Interfaces MIB

### Improved Accounting Capability

By viewing the MPLS layer, you get MPLS-encapsulated traffic counters that do not include non-MPLS encapsulated traffic (for example, IP packets). Therefore, the counters are more useful for MPLS-related statistics.

### TE Tunnel Interfaces

For TE tunnel interfaces, the stacking relationship reflects the current underlying MPLS interface that is in use and dynamically changes as TE tunnels reoptimize and reroute.

### MPLS-Specific Information

The MPLS layer shows MPLS-specific information including the following:

- If MPLS is enabled
- MPLS counters
- MPLS MTU
- MPLS operational status

## How to Configure MPLS Enhancements to Interfaces MIB

This section contains the following procedures:

- [Enabling the SNMP Agent, page 8](#) (required)
- [Verifying That the SNMP Agent Has Been Enabled, page 9](#) (optional)

### Enabling the SNMP Agent

Perform the following task to enable the SNMP agent.

#### SUMMARY STEPS

1. **enable**
2. **show running-config**
3. **configure terminal**
4. **snmp-server community** *string* [**view** *view-name*] [**ro**] [*number*]
5. **end**
6. **write memory**

## DETAILED STEPS

	Command or Action	Purpose
Step 1	<b>enable</b>  <b>Example:</b> Router> enable	Enables privileged EXEC mode. <ul style="list-style-type: none"> <li>Enter your password if prompted.</li> </ul>
Step 2	<b>show running-config</b>  <b>Example:</b> Router# show running-config	Displays the running configuration of the router so that you can determine if an SNMP agent is already running on the device.  If no SNMP information is displayed, continue with the next step.  If any SNMP information is displayed, you can modify the information or change it as desired.
Step 3	<b>configure terminal</b>  <b>Example:</b> Router# configure terminal	Enters global configuration mode.
Step 4	<b>snmp-server community</b> <i>string</i> [ <b>view</b> <i>view-name</i> ] [ <b>ro</b> ] [ <i>number</i> ]  <b>Example:</b> Router(config)# snmp-server community public ro	Configures read-only (ro) community strings for the MPLS Label Distribution Protocol (LDP) MIB. <ul style="list-style-type: none"> <li>The <i>string</i> argument functions like a password, permitting access to SNMP functionality on label switch routers (LSRs) in an MPLS network.</li> <li>The optional <b>ro</b> keyword configures read-only (ro) access to the objects in the MPLS LDP MIB.</li> </ul>
Step 5	<b>end</b>  <b>Example:</b> Router(config)# end	Exits to privileged EXEC mode.
Step 6	<b>write memory</b>  <b>Example:</b> Router# write memory	Writes the modified SNMP configuration into NVRAM of the router, permanently saving the SNMP settings.

## Verifying That the SNMP Agent Has Been Enabled

Perform the following task to verify that the SNMP agent has been enabled.

## SUMMARY STEPS

- enable
- show running-config

## DETAILED STEPS

	Command or Action	Purpose
Step 1	<b>enable</b>  <b>Example:</b> Router> enable	Enables privileged EXEC mode. <ul style="list-style-type: none"> <li>Enter your password if prompted.</li> </ul>
Step 2	<b>show running-config</b>  <b>Example:</b> Router# show running-config	Displays the running configuration of the router so that you can determine if an SNMP agent is already running on the device. <p>If you see any snmp-server statements, SNMP has been enabled on the router.</p> <p>If no SNMP information is displayed, continue with the next step.</p> <p>If any SNMP information is displayed, you can modify the information or change it as desired.</p>

## Configuration Examples for the MPLS Enhancements to Interfaces MIB

This section provides the following configuration examples:

- [MPLS Enhancements to Interfaces MIB: Examples, page 10](#)

### MPLS Enhancements to Interfaces MIB: Examples

The following example shows how to enable an SNMP agent:

```
Router# configure terminal
Router(config)# snmp-server community
```

In the following example, SNMPv1 and SNMPv2C are enabled. The configuration permits any SNMP manager to access all objects with read-only permissions using the community string public.

```
Router(config)# snmp-server community public
```

In the following example, read-only access is allowed for all objects to members of access list 4 that specify the comaccess community string. No other SNMP managers have access to any objects.

```
Router(config)# snmp-server community comaccess ro 4
```

## Additional References

The following sections provide references related to the MPLS Enhancements to Interfaces MIB feature.

### Related Documents

Related Topic	Document Title
SNMP commands	<ul style="list-style-type: none"> <li>• <a href="#">Cisco IOS Network Management Command Reference, Release 12.4T</a></li> <li>• <a href="#">Cisco IOS Network Management Command Reference, Release 12.2SB</a></li> <li>• <a href="#">Cisco IOS Network Management Command Reference, Release 12.2SR</a></li> </ul>
SNMP configuration	“Configuring SNMP support” in the <a href="#">Cisco IOS Network Management Configuration Guide, Release 12.4</a>
A description of SNMP agent support in Cisco IOS for the MPLS Label Switching Router MIB (MPLS-LSR-MIB)	<a href="#">MPLS Label Switching Router MIB</a>
A description of SNMP agent support in Cisco IOS for the MPLS Traffic Engineering MIB (MPLS TE MIB)	<a href="#">MPLS Traffic Engineering (TE) MIB</a>
Other documentation	<p>“<i>Multiprotocol Label Switching (MPLS) Label Switch Router (LSR) Management Information Base</i>,” Internet draft, January 2002 [draft-ietf-mpls-lsr-mib-08.txt]; Srinivasan, C., Viswanathan, A., and Nadeau, T.D.</p> <p><b>Note</b> For information on using SNMP MIB features, see the appropriate documentation for your network management system.</p>

### Standards

Standards	Title
No new or modified standards are supported by this feature, and support for existing standards has not been modified by this feature.	—

### MIBs

MIBs	MIBs Link
Interfaces Group MIB (IF MIB)	<p>To locate and download MIBs for selected platforms, Cisco IOS releases, and feature sets, use Cisco MIB Locator found at the following URL:</p> <p><a href="http://www.cisco.com/go/mibs">http://www.cisco.com/go/mibs</a></p>

## RFCs

RFCs	Title
RFC 1156	<i>Management Information Base for Network Management of TCP/IP-based internets</i>
RFC 1157	<i>A Simple Network Management Protocol (SNMP)</i>
RFC 1213	<i>Management Information Base for Network Management of TCP/IP-based internets: MIB-II</i>
RFC 1229	<i>Extensions to the Generic-Interface MIB</i>
RFC 2233	<i>Interfaces MIB</i>

## Technical Assistance

Description	Link
<p>The Cisco Support website provides extensive online resources, including documentation and tools for troubleshooting and resolving technical issues with Cisco products and technologies.</p> <p>To receive security and technical information about your products, you can subscribe to various services, such as the Product Alert Tool (accessed from Field Notices), the Cisco Technical Services Newsletter, and Really Simple Syndication (RSS) Feeds.</p> <p>Access to most tools on the Cisco Support website requires a Cisco.com user ID and password.</p>	<a href="http://www.cisco.com/techsupport">http://www.cisco.com/techsupport</a>

## Command Reference

This section documents only commands that are new or modified.

- [snmp-server community](#)

# snmp-server community

To set up the community access string to permit access to the Simple Network Management Protocol (SNMP), use the **snmp-server community** command in global configuration mode. To remove the specified community string, use the **no** form of this command.

```
snmp-server community string [view view-name] [ro | rw] [ipv6 nacl] [access-list-number]
```

```
no snmp-server community string
```

## Syntax Description

<i>string</i>	Community string that consists of 1 to 32 alphanumeric characters and functions much like a password, permitting access to SNMP. Blank spaces are not permitted in the community string.  <b>Note</b> The @ symbol is used for delimiting the context information. Avoid using the @ symbol as part of the SNMP community string when configuring this command.
<b>view</b>	(Optional) Specifies a previously defined view. The view defines the objects available to the SNMP community.
<i>view-name</i>	(Optional) Name of a previously defined view.
<b>ro</b>	(Optional) Specifies read-only access. Authorized management stations can retrieve only MIB objects.
<b>rw</b>	(Optional) Specifies read-write access. Authorized management stations can both retrieve and modify MIB objects.
<b>ipv6</b>	(Optional) Specifies an IPv6 named access list.
<i>nacl</i>	(Optional) IPv6 named access list.
<i>access-list-number</i>	(Optional) Integer from 1 to 99 that specifies a standard access list of IP addresses or a string (not to exceed 64 characters) that is the name of a standard access list of IP addresses allowed access to the SNMP agent.  Alternatively, an integer from 1300 to 1999 that specifies a list of IP addresses in the expanded range of standard access list numbers that are allowed to use the community string to gain access to the SNMP agent.

## Command Default

An SNMP community string permits read-only access to all objects.



### Note

If the **snmp-server community** command is not used during the SNMP configuration session, the command will automatically be added to the configuration after the **snmp host** command is used. In this case, the default password (*string*) for the **snmp-server community** command will be taken from the **snmp host** command.

## Command Modes

Global configuration (config)

**Command History**

Release	Modification
10.0	This command was introduced.
12.0(14)ST	This command was integrated into Cisco IOS Release 12.0(14)ST.
12.0(17)S	This command was integrated into Cisco IOS Release 12.0(17)S.
12.2(14)S	This command was integrated into Cisco IOS Release 12.2(14)S.
12.3(2)T	The access list values were enhanced to support the expanded range of standard access list values and to support named standard access lists.
12.0(27)S	The <b>ipv6 nacl</b> keyword and argument pair was added to support assignment of IPv6 named access lists. This keyword and argument pair is not supported in Cisco IOS 12.2S releases.
12.3(14)T	The <b>ipv6 nacl</b> keyword and argument pair was integrated into Cisco IOS Release 12.3(14)T to support assignment of IPv6 named access lists. This keyword and argument pair is not supported in Cisco IOS 12.2S releases.
12.2(28)SB	This command was integrated into Cisco IOS Release 12.2(28)SB.
12.2(33)SRA	This command was integrated into Cisco IOS Release 12.2(33)SRA.
12.4(11)T	This command was integrated into Cisco IOS Release 12.4(11)T.
12.2(31)SB2	This command was integrated into Cisco IOS Release 12.2(31)SB2.
12.2(33)SXH	This command was integrated into Cisco IOS Release 12.2(33)SXH.

**Usage Guidelines**

The **no snmp-server** command disables all versions of SNMP (SNMPv1, SNMPv2C, SNMPv3).

The first **snmp-server** command that you enter enables all versions of SNMP.

To configure SNMP community strings for the MPLS LDP MIB, use the **snmp-server community** command on the host network management station (NMS).

The **snmp-server community** command can be used to specify only an IPv6 named access list, only an IPv4 access list, or both.

For you to configure both IPv4 and IPv6 access lists, the IPv6 access list must appear first in the command statement.

**Note**

The @ symbol is used as a delimiter between the community string and the context in which it is used. For example, specific VLAN information in BRIDGE-MIB may be polled using `community@VLAN_ID` (for example, `public@100`) where 100 is the VLAN number. Avoid using the @ symbol as part of the SNMP community string when configuring this command.

**Examples**

The following example shows how to set the read/write community string to newstring:

```
Router(config)# snmp-server community newstring rw
```

The following example shows how to allow read-only access for all objects to members of the standard named access list lmnop that specify the comaccess community string. No other SNMP managers have access to any objects.

```
Router(config)# snmp-server community comaccess ro lmnop
```

The following example shows how to assign the string comaccess to SNMP, allow read-only access, and specify that IP access list 4 can use the community string:

```
Router(config)# snmp-server community comaccess ro 4
```

The following example shows how to assign the string manager to SNMP and allow read-write access to the objects in the restricted view:

```
Router(config)# snmp-server community manager view restricted rw
```

The following example shows how to remove the community comaccess:

```
Router(config)# no snmp-server community comaccess
```

The following example shows how to disable all versions of SNMP:

```
Router(config)# no snmp-server
```

The following example shows how to configure an IPv6 access list named list1 and links an SNMP community string with this access list:

```
Router(config)# ipv6 access-list list1
Router(config-ipv6-acl)# permit ipv6 any any
Router(config-ipv6-acl)# exit
Router(config)# snmp-server community comaccess rw ipv6 list1
```

#### Related Commands

Command	Description
<b>access-list</b>	Configures the access list mechanism for filtering frames by protocol type or vendor code.
<b>snmp-server enable traps</b>	Enables the router to send SNMP notification messages to a designated network management workstation.
<b>snmp-server host</b>	Specifies the targeted recipient of an SNMP notification operation.
<b>snmp-server view</b>	Creates or updates a view entry.

# Glossary

**ATM**—Asynchronous Transfer Mode. The international standard for cell relay in which multiple service types (such as voice, video, or data) are conveyed in fixed-length (53-byte) cells. Fixed-length cells allow cell processing to occur in hardware, thereby reducing transit delays. ATM is designed to take advantage of high-speed transmission media, such as E3, SONET, and T3.

**ATM-AAL5**—ATM adaptation layer 5. One of four AALs recommended by the ITU-T. AAL5 supports connection-oriented variable bit rate (VBR) services and is used predominantly for the transfer of classical IP over ATM and LAN emulation (LANE) traffic. AAL5 uses simple and efficient AAL (SEAL) and is the least complex of the current AAL recommendations. It offers low bandwidth overhead and simpler processing requirements in exchange for reduced bandwidth capacity and error-recovery capability.

**encapsulation**—Wrapping of data in a particular protocol header. For example, Ethernet data is wrapped in a specific Ethernet header before network transit. Also, when bridging dissimilar networks, the entire frame from one network is simply placed in the header used by the data link layer protocol of the other network.

**IETF**—Internet Engineering Task Force. A task force (consisting of more than 80 working groups) that is developing standards for the Internet and the IP suite of protocols.

**interface**—The boundary between adjacent layers of the ISO model.

**label**—A short, fixed-length identifier that is used to determine the forwarding of a packet.

**label switching**—A term used to describe the forwarding of IP (or other network layer) packets using a label swapping algorithm based on network layer routing algorithms. The forwarding of these packets uses the exact match algorithm and rewrites the label.

**LSR**—label switching router. A device that forwards MPLS packets based on the value of a fixed-length label encapsulated in each packet.

**MIB**—Management Information Base. A database of network management information that is used and maintained by a network management protocol such as SNMP. The value of a MIB object can be changed or retrieved by means of SNMP commands, usually through a network management system. MIB objects are organized in a tree structure that includes public (standard) and private (proprietary) branches.

**MPLS**—Multiprotocol Label Switching. A method for forwarding packets (frames) through a network. It enables routers at the edge of a network to apply labels to packets (frames). ATM switches or existing routers in the network core can switch packets according to the labels with minimal lookup overhead.

**MPLS interface**—An interface on which MPLS traffic is enabled.

**MTU**—maximum transmission unit. Maximum packet size, in bytes, that a particular interface can handle.

**NMS**—network management system. System responsible for managing at least part of a network. An NMS is generally a reasonably powerful and well-equipped computer, such as an engineering workstation. NMSs communicate with agents to help keep track of network statistics and resources.

**OID**—object identifier. Values are defined in specific MIB modules. The Event MIB allows you or an NMS to watch over specified objects and to set event triggers based on existence, threshold, and Boolean tests. An event occurs when a trigger is fired; this means that a specified test on an object returns a value of true. To create a trigger, you or an NMS configures a trigger entry in the `mteTriggerTable` of the Event MIB. This trigger entry specifies the OID of the object to be watched. For each trigger entry type, corresponding tables (existence, threshold, and Boolean tables) are populated with the information required for carrying out the test. The MIB can be configured so that when triggers are activated (fired) either an SNMP Set is performed, a notification is sent out to the interested host, or both.

**SNMP**—Simple Network Management Protocol. A management protocol used almost exclusively in TCP/IP networks. SNMP provides a means for monitoring and controlling network devices, and for managing configurations, statistics collection, performance, and security.

**traffic engineering tunnel**—A label-switched tunnel that is used for traffic engineering. Such a tunnel is set up through means other than normal Layer 3 routing; it is used to direct traffic over a path different from the one that Layer 3 routing could cause the tunnel to take.

**trap**—A message sent by an SNMP agent to a network management station, console, or terminal, indicating that a significant event occurred. Traps are less reliable than notification requests, because the receiver does not send an acknowledgment when it receives a trap. The sender cannot determine if the trap was received.

**tunnel**—A secure communication path between two peers, such as routers.

---

CCVP, the Cisco logo, and the Cisco Square Bridge logo are trademarks of Cisco Systems, Inc.; Changing the Way We Work, Live, Play, and Learn is a service mark of Cisco Systems, Inc.; and Access Registrar, Aironet, BPX, Catalyst, CCDA, CCDP, CCIE, CCIP, CCNA, CCNP, CCSP, Cisco, the Cisco Certified Internetwork Expert logo, Cisco IOS, Cisco Press, Cisco Systems, Cisco Systems Capital, the Cisco Systems logo, Cisco Unity, Enterprise/Solver, EtherChannel, EtherFast, EtherSwitch, Fast Step, Follow Me Browsing, FormShare, GigaDrive, HomeLink, Internet Quotient, IOS, iPhone, IP/TV, iQ Expertise, the iQ logo, iQ Net Readiness Scorecard, iQuick Study, LightStream, Linksys, MeetingPlace, MGX, Networking Academy, Network Registrar, *Packet*, PIX, ProConnect, ScriptShare, SMARTnet, StackWise, The Fastest Way to Increase Your Internet Quotient, and TransPath are registered trademarks of Cisco Systems, Inc. and/or its affiliates in the United States and certain other countries.

All other trademarks mentioned in this document or Website are the property of their respective owners. The use of the word partner does not imply a partnership relationship between Cisco and any other company. (0705R)

Any Internet Protocol (IP) addresses used in this document are not intended to be actual addresses. Any examples, command display output, and figures included in the document are shown for illustrative purposes only. Any use of actual IP addresses in illustrative content is unintentional and coincidental.

© 2004–2007 Cisco Systems, Inc. All rights reserved.

