



AIM-ATM, AIM-VOICE-30, and AIM-ATM-VOICE-30 on the Cisco 2600 Series, Cisco 3660, and Cisco 3700 Series

This document describes configurations for the AIM-ATM, AIM-VOICE-30, and AIM-ATM-VOICE-30 on the Cisco 2600 series, the Cisco 3660, and the Cisco 3700 series.

The Cisco 2600 series has one internal slot for an AIM, and the Cisco 3660 and Cisco 3700 series have two. Three types of AIM provide components that provide the following ATM and voice processing services:

- Segmentation and reassembly (SAR) of packets for ATM transport over a wide-area network (WAN), utilizing ATM Adaptation Layer 2 (AAL2) and AAL5 encapsulation and providing ATM WAN uplinks on up to four T1/E1 links
- Digital signal processing (DSP) for voice conversion, providing termination and processing of up to 30 voice channels per AIM
- Multiplexing over ATM (IMA), version 1.1. Version 1.1 is interoperable with Version 1.0.

Benefits of this feature include the following:

- Introduces Voice over ATM (VoATM) on the 2600
- Introduces VoAAL2 support on the Cisco 2600 series, Cisco 3660, and Cisco 3700 series
- Inexpensive ATM access
- Dedicated onboard AIM hardware-accelerated coprocessor, capable of supporting both AAL2 (ITU I.366.1/I363.2) and VoAAL5, which offloads the processor-intensive task of ATM cell segmentation and reassembly from the main router CPU.
- ATM WAN uplink option for Cisco 2600 series routers without using a network module slot
- AAL2 or AAL5 encapsulation for high quality of service (QoS) and a low-cost alternative to circuit-based services
- Efficient prioritization of mission-critical data provided by ATM's QoS
- Low-density T1 or E1 ATM option on an AIM form factor, providing a VoATM, Voice over IP (VoIP), or Voice over Frame Relay (VoFR) solution supporting up to four T1 or four E1s
- Inverse multiplexing over ATM (IMA) for connection of up to four T1s or E1s, for the most effective use of available slots
- No need for third-party IMA devices
- Migration path to higher bandwidth without the need to change transport facilities

- Highly competitive voice processing (termination) solution with AIM-VOICE-30 at a density of 30 VoIP, VoFR voice, or fax channels, while not consuming a network module slot

Feature Specifications for the AIM-ATM, AIM-VOICE-30, and AIM-ATM-VOICE-30 on the Cisco 2600 Series, Cisco 3660, and Cisco 3700 Series Feature

Feature History

Release	Modification
12.2(2)XA	The High-Performance ATM Advanced Integration Module (AIM-ATM) was introduced for support of AAL2 and AAL5 services on the Cisco 2600 series.
12.2(2)XB	The following capabilities were added to this feature: <ul style="list-style-type: none"> • Support for the High-Performance ATM Advanced Integration Module (AIM-ATM) on the Cisco 3660 • Two new types of Advanced Integration Modules (AIMs): <ul style="list-style-type: none"> – AIM-VOICE-30, which provides support for voice DSP services for the Cisco 2600 series and the Cisco 3660 – AIM-ATM-VOICE-30, which combines support for both ATM and voice DSP services for the Cisco 2600 series and the Cisco 3660 • Support for Inverse Multiplexing over ATM (IMA) for the Cisco 2600 series and Cisco 3660 • Support for Fast Ethernet network modules (NM-2W on the Cisco 2600 series, and NM-2W, NM-1FE2W, and NM-2FE2W on the Cisco 3660) with multiflex trunk Voice/WAN Interface Cards (VWICs) (VWIC-MFT)
12.2(8)T	This feature was integrated into Cisco IOS Release 12.2(8)T on the Cisco 2600 series and the Cisco 3660.
12.2(15)T	This feature was implemented on the Cisco 2691 and the Cisco 3700 series. New features were added. Refer to the <i>Integrated Voice and Data WAN on T1/E1 Interfaces Using the AIM-ATM-VOICE-30 Module</i> for information about new features used by this feature.

Supported Platforms

For platforms supported in Cisco IOS Release 12.2(15)T, consult Cisco Feature Navigator.

Finding Support Information for Platforms and Cisco IOS Software Images

Use Cisco Feature Navigator to find information about platform support and Cisco IOS software image support. Access Cisco Feature Navigator at <http://www.cisco.com/go/fn>. You must have an account on Cisco.com. If you do not have an account or have forgotten your username or password, click **Cancel** at the login dialog box and follow the instructions that appear.

Contents

- [Prerequisites for AIM-ATM, AIM-VOICE-30, and AIM-ATM-VOICE-30, page 7](#)
- [Restrictions for the AIM-ATM, AIM-VOICE-30, and AIM-ATM-VOICE-30, page 7](#)
- [Information About the AIM-ATM, AIM-VOICE-30, and AIM-ATM-VOICE-30 Feature, page 8](#)
- [Configuration Tasks, page 15](#)

- [Configuration Examples, page 29](#)
- [Additional References, page 33](#)
- [Command Reference, page 35](#)
- [Glossary, page 52](#)

Prerequisites for AIM-ATM, AIM-VOICE-30, and AIM-ATM-VOICE-30

Cisco 2600 series

- Cisco IOS Release 12.2(2)XB IP Plus, Cisco IOS Release 12.2(8)T, or a later release
- 64 MB RAM and 16 MB Flash memory
- Appropriate voice interface hardware, as listed in [Table 1](#)
- Voice over ATM, Voice over IP, or Voice over Frame Relay network. See the appropriate document from the [“Related Documents” section on page 34](#).

Cisco 3660

- Cisco IOS Release 12.2(2)XB IP Plus, Cisco IOS Release 12.2(8)T, or a later release
- 64 MB RAM and 16 MB Flash memory
- MIX module (MIX-3660-64) installed in the time-division multiplexing (TDM) slot on the motherboard
- Appropriate voice interface hardware as listed in [Table 1](#)
- Voice over ATM, Voice over IP, or Voice over Frame Relay network. See the appropriate document from the [“Related Documents” section on page 34](#).

Cisco 3700 series

- Cisco IOS Release 12.2(13)T, or a later release
- 64 MB RAM and 16 MB Flash memory
- Appropriate voice interface hardware as listed in [Table 1](#)
- Voice over ATM, Voice over IP, or Voice over Frame Relay network. See the appropriate document from the [“Related Documents” section on page 34](#).

Restrictions for the AIM-ATM, AIM-VOICE-30, and AIM-ATM-VOICE-30

- High-complexity codecs are not supported for DSP processing before Cisco IOS Release 12.2(15)T.
- Cisco 3660 routers must be configured with a multiservice interchange (MIX) module.
- On Cisco 2600 series routers, if some DSP functionality is used for one port, the remaining DSP functionality cannot be used on the other port.
- Frame Relay and ATM cannot be configured on two different ports of one WIC card in a Cisco 2600 WIC slot.

- AAL2 supports a permanent virtual circuit (PVC); AAL5 supports PVC and a switched virtual circuit (SVC). Note that voice is supported only on PVCs. The SVC support on AAL5 is for data only.
- Subcell multiplexing is defaulted and is not configurable.
- A maximum of four IMA groups can be configured on a Cisco 2600 series router with one AIM installed, or on a Cisco 3660 router with either one or two AIMS installed.
- IMA cannot be multiplexed across two different AIM-ATMs or AIM-ATM-VOICE-30s on a Cisco 3660.
- When using AIM-ATM, AIM-VOICE-30, or AIM-ATM-VOICE-30, the number of virtual path identifier (VPI) and virtual channel identifier (VCI) bits is 13. The VPI default is five bits with a range of 0 to 31; the VCI default is eight bits with a range of 1 to 255. A 100/200 permanent virtual circuit (PVC) is not possible, because the maximum number of bits for VPI/VCI is 13.
- An AIM-ATM-VOICE-30 can support a maximum of four interfaces (8 MB TDM stream from the AIM-ATM-VOICE-30). There cannot be, for instance, four ATM interfaces and two voice or DSP interfaces on a Cisco 2600. A Cisco 2600 series can have four ATM interfaces and zero voice interfaces, or it can have three ATM interfaces plus one voice interface.
- For variable-bit-rate, real-time (VBR-RT) traffic shaping, maximum burst size (MBS) is 255 cells.
- The lowest traffic shaping parameter supported is 32 kbps.
- VBR.3/CLP tagging is not supported.
- You cannot run software SAR and the AIM-ATM, AIM-VOICE-30, and AIM-ATM-VOICE-30 on the Cisco 2600 Series, Cisco 3660, and Cisco 3700 Series feature on the same 8-port multi-rate OCn interface.
- Drop and Insert are not supported on the Cisco 2600 series.
- You must configure **mode cas** before configuring the controller for TCCS clear channel in Cisco IOS software images before Cisco IOS Release 12.2T.
- Memory requirements:
 - Cisco 2650 and Cisco 2651 routers running a -js- image require a minimum of 128 MB DRAM when using AIM-VOICE-30 or AIM-ATM-VOICE-30 modules with NM-HDV-24 or NM-HDV-30 network modules.
 - Cisco 2610, Cisco 2611, Cisco 2612, Cisco 2613, Cisco 2620, Cisco 2621, Cisco 2650, and Cisco 2651 routers running an -is- image require a minimum of 64 MB DRAM when using AIM-VOICE-30 or AIM-ATM-VOICE-30 modules with NM-HDV-24 or NM-HDV-30 network modules.
 - For all other configurations, refer to the Memory Recommendations in the [Platform Specific Information](#) for Cisco IOS Release 12.2(15)T.

Information About the AIM-ATM, AIM-VOICE-30, and AIM-ATM-VOICE-30 Feature

Before you configure the AIM-ATM, AIM-VOICE-30 or AIM-ATM-VOICE-30, you should understand the following concepts:

- [AIM-ATM, page 9](#)
- [AIM-VOICE-30, page 9](#)

- [AIM-ATM-VOICE-30, page 9](#)
- [AIM Features, page 10](#)
- [ATM Features, page 10](#)
- [Voice DSP Features, page 10](#)

AIM-ATM

The High-Performance ATM AIM enables voice and data traffic to be carried over ATM networks using AAL2 and AAL5 encapsulation when installed in the Cisco 2600 series, Cisco 3660, or Cisco 3700 series. If used in conjunction with a T1/E1 multiflex trunk voice/WAN interface card (VWIC-MFT) for circuit-mode data and frame-mode data over ATM infrastructures, ATM AIM supports up to four T1 or E1 WAN interfaces. These interfaces may be four independent links or four inverse IMA groups.

When using the voice DSP capability of a digital T1/E1 packet voice trunk network module (NM-HDV) and a T1/E1 multiflex trunk VWIC, ATM AIM supports as many as 30 channels of compressed voice over a T1/E1 trunk using AAL2 or AAL5. Analog VoATM is enabled with a voice/fax network module (NM-1V or NM-2V) and a voice interface card, which can support as many as four analog voice calls using AAL5. All voice interface cards are supported: FXS, FXO, Analog-DID, E&M, and BRI.

AIM-VOICE-30

The AIM-VOICE-30 is capable of supporting up to 30 voice or fax channels when used in a Cisco 2600 series, Cisco 3660, or Cisco 3700 series with one of the T1/E1 voice/WAN interface cards (such as VWIC-1T1). This AIM includes powerful DSPs that are used for a number of voice processing tasks such as voice compression and decompression, voice activity detection or silence suppression, and private branch exchange (PBX) or public switched telephone network (PSTN) signaling protocols.

By using the AIM-VOICE-30 in a Cisco 2600 series router, you can support VoIP or VoFR while leaving the router's network module slot open for other functions such as asynchronous or synchronous serial concentration. When used in combination with one of the various ATM network modules, VoATM or VoIP over ATM can be provisioned using AAL5 and Voice over AAL2 (VoAAL2).

AIM-ATM-VOICE-30

This card is a combined ATM and DSP AIM that supports VoATM, voice over IP (VoIP), and voice over Frame Relay (VoFR). It supports as many as four T1 or E1 trunks when installed in a Cisco 2600 series, Cisco 3660, or Cisco 3700 series.

This AIM is used in combination with one T1/E1 multiflex trunk interface (VWIC-MFT) to provide PBX or PSTN signaling protocols. It uses VoAAL2 (ITU I.366.1/I.363.2) and VoAAL5 and does not require use of a digital T1/E1 packet voice trunk network module. This AIM has an onboard ATM coprocessor for increased AAL2 and AAL5 performance, and for as many as four IMA groups, enabling fractional T3 or E3 bandwidth performance.

See [Table 1 on page 13](#) for a summary of capabilities and voice interface hardware for each platform.

AIM Features

General features for all three types of AIM include the following:

- One AIM can be installed on a Cisco 2600 series router, and up to two AIMS can be installed on a Cisco 3660 or Cisco 3700 series.
- Online insertion and removal (OIR) is supported for the network modules that interoperate with AIMS on the Cisco 3660 or Cisco 3700 series.

ATM Features

ATM features for AIM-ATM and AIM-ATM-VOICE-30 include the following:

- For Cisco 2600 series routers, up to four ATM ports using multiflex trunk VWICS located either in WIC slots or in network modules, such as Fast Ethernet network modules or digital T1/E1 packet voice trunk network modules
- For Cisco 3660 or Cisco 3700 series with two AIMS, up to eight ATM ports using multiflex trunk VWICS located in network modules, such as Fast Ethernet network modules or digital T1/E1 packet voice trunk network modules
- AAL5 and AAL2 services
- IMA 1.1 support for up to four IMA links per AIM
- Up to 1024 AAL5 VCs for data or voice features per AIM
- Up to 1024 AAL2 VCs with up to 255 subchannels each for voice per AIM
- Network clock management support for synchronization between the ATM network and a PBX or the PSTN

Voice DSP Features

Voice DSP features for AIM-VOICE-30 and AIM-ATM-VOICE-30 include the following:

- Voice AIMS support all the same signaling types that are normally supported on T1 and E1 lines connected to NM-HDV network modules
- Integration of complete network management (Simple Management Network Protocol [SNMP], Cisco Voice Manager [CVM], CiscoView)
- VoIP, VoFR, VoAAL5, and VoAAL2
- Voice over AAL5
 - Cisco AAL5 switched-voice support
 - VoIP over ATM
 - Transparent Common Channel Signaling (T-CCS)
- Voice over AAL2
 - Nonswitched VoAAL2 trunking support
 - Voice compression with AAL2 for subcell multiplexing on multiple calls
 - Transparent Common Channel Signaling (T-CCS)

- Medium complexity DSP firmware, including the following codecs: G.711 u-law, G.711 a-law, G.729a, G.729ab, G.726r16, G.726r24, G.726r32, clear channel, and fax-relay.
- Up to 30 simultaneous voice calls per AIM
- Up to 60 simultaneous voice calls using DSPs on digital T1/E1 packet voice trunk network modules

Figure 1 represents applications that require both data and voice, as well as T1 or E1 ATM connections. In this scenario, voice is transmitted over ATM using AAL2 protocol. Bandwidth efficiency is achieved by powerful DSPs driving a full range of codecs and subcell multiplexing. By using a digital T1 or E1 packet voice trunk network module (NM-HDV), this configuration supports up to 60 channels of compressed voice over a T1 or E1 ATM trunk. In this scenario, PBXs can be directly connected to the NM-HDV, allowing for VoIP, VoFR, or VoATM support. Data traffic over AAL5 can be combined with voice-specific traffic.

Figure 1 AIM-ATM Providing ATM and Network Module Providing Voice DSP

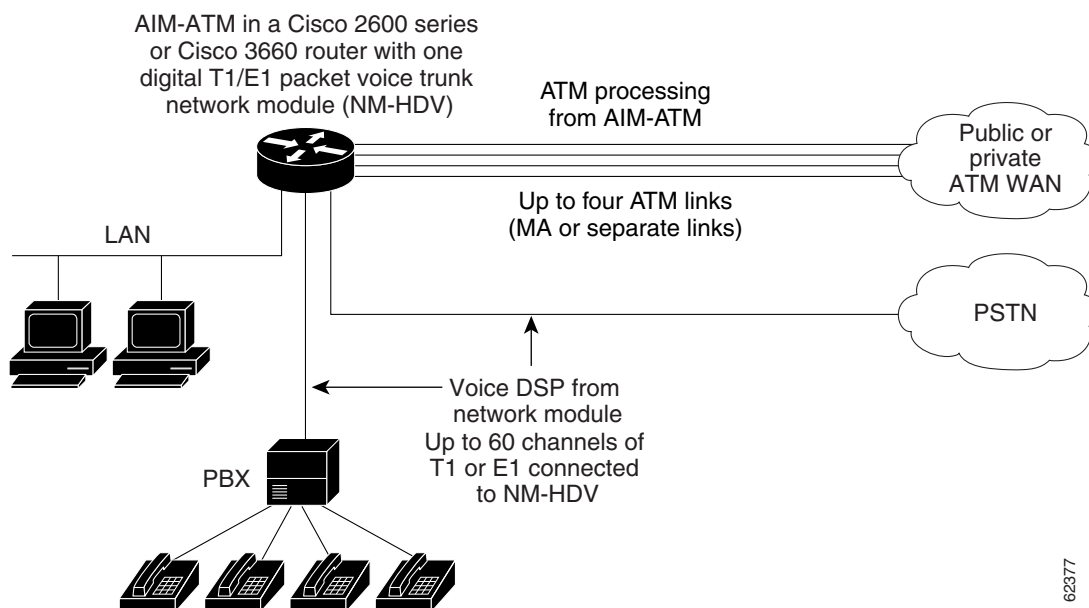

62377

Figure 2 illustrates a router with a network module that is being used for services other than voice. Applications on this router are limited to 30 or fewer voice or fax channels. When an AIM-VOICE-30 is used in conjunction with a T1 or E1 voice/WAN interface (such as VWIC-1MFT-T1/E1), it can provide voice processing such as VoIP or VoFR in conjunction with a PBX within the branch office, leaving the network module slot open for other applications. Note that you cannot process the T1 or E1 voice on the same VWIC as the serial WAN connection. They have to use different VWICs.

Figure 2 AIM-VOICE-30 Providing DSP for Voice

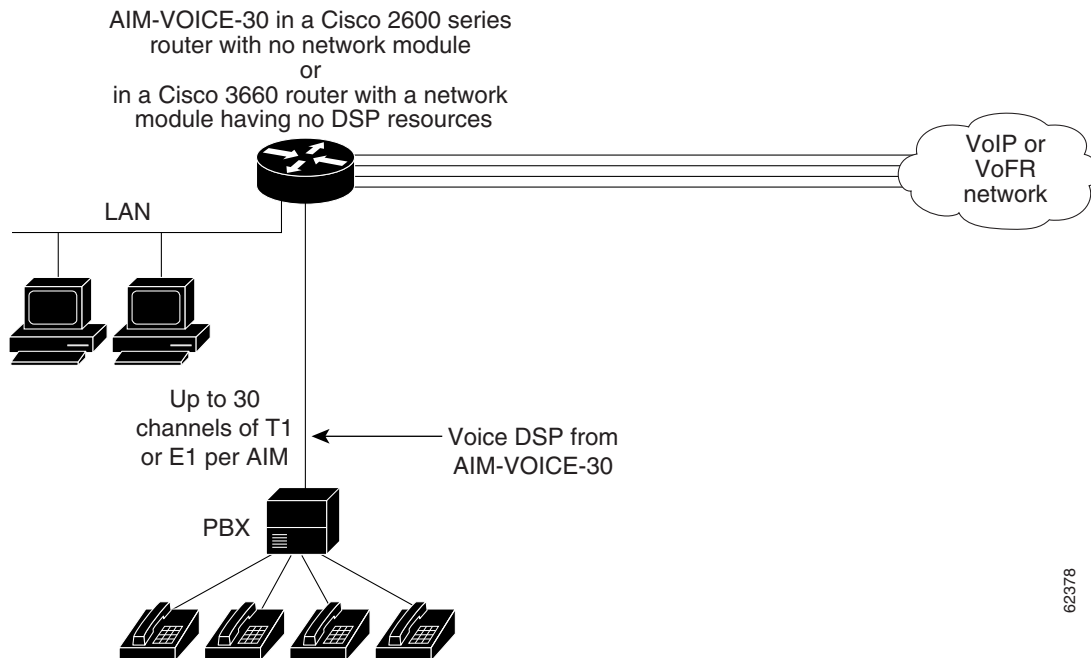
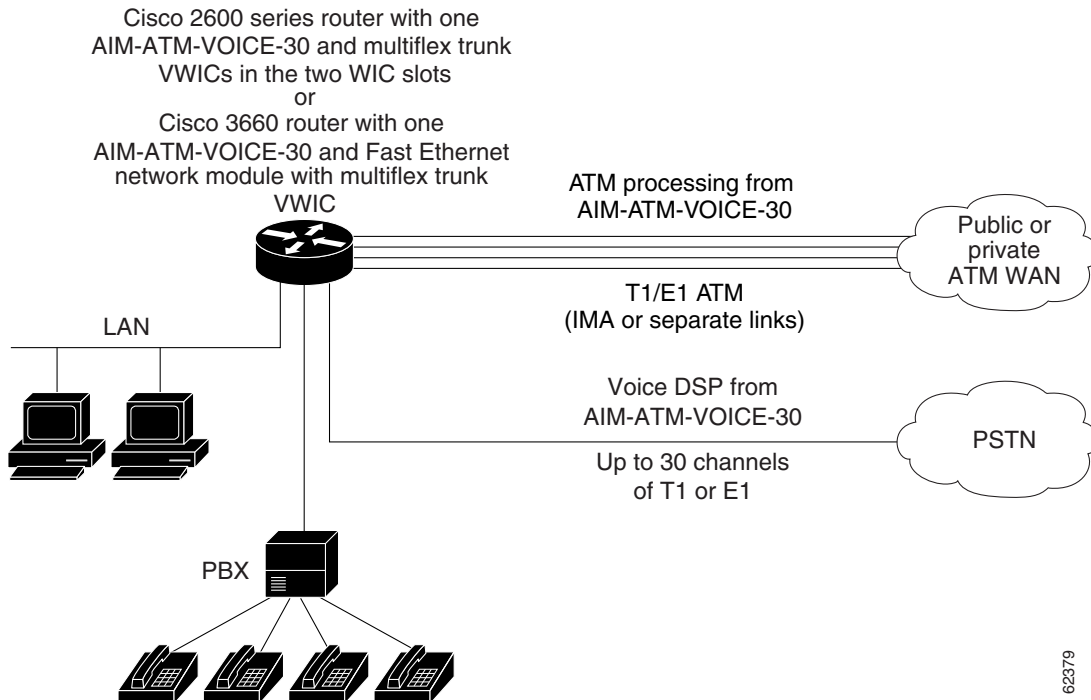

Figure 3 depicts applications that require AAL5 or AAL2 support over T1 or E1 ATM connections. This configuration leaves the network module slot open for existing or future needs. In this example, the AIM-ATM-VOICE-30 combines all of the AIM features shown in Figure 1 and Figure 2, including support for up to 30 channels of compressed voice using AAL2 (ITU I.366.1/I.363.2) and VoAAL5 with the support of a T1/E1 voice/WAN interface (VWIC-1MFT-T1/E1) connected to a PBX, without requiring a digital T1/E1 packet voice trunk network module. In addition, the AIM-ATM-VOICE-30's SAR coprocessor functionality provides AAL2 and AAL5 performance and as many as four IMA groups, enabling fractional T3/E3 bandwidth performance.

Figure 3 AIM-ATM-VOICE-30 Providing ATM and DSP for Voice



62379

Table 1 lists the applications and voice interfaces that can be used with the three types of AIM:

Table 1 AIM-ATM, AIM-VOICE-30, and AIM-ATM-VOICE-30 Applications

Application	Platform	AIM	Interface
1- to 4-port T1/E1 Data and Analog Voice over an ATM Network	Cisco 2600 series, Cisco 3660, ¹ and Cisco 3700 series	AIM-ATM	<ul style="list-style-type: none"> Two-port voice interface card (VIC-2FXS) in a voice/fax network module (Any NM-1V or NM-2V card: FXS, FXO, E&M, DID, and BRI are supported) Multiflex trunk VWIC (VWIC-1MFT, for example)
1- to 4-port T1/E1 Data over an ATM Network	Cisco 2600 series, Cisco 3660, and Cisco 3700 series	AIM-ATM	Multiflex trunk VWIC (VWIC-1MFT, for example) in one of the following: <ul style="list-style-type: none"> WIC slot Digital T1/E1 packet voice trunk network module (NM-HDV) Fast Ethernet network module (NM-2W)

Table 1 AIM-ATM, AIM-VOICE-30, and AIM-ATM-VOICE-30 Applications

Application	Platform	AIM	Interface
1- to 4-port T1/E1 Data over an ATM Network with IMA	Cisco 2600 series, Cisco 3660, ¹ and Cisco 3700 series	AIM-ATM	Multiflex trunk VWIC (VWIC-1MFT, for example) in one of the following: <ul style="list-style-type: none"> • WIC slot (Cisco 2600 series only)
1- to 4-port T1/E1 Data and Digital Voice over an ATM Network with IMA	Cisco 2600 series and Cisco 3660 ¹	AIM-ATM-VOICE-30	<ul style="list-style-type: none"> • Digital T1/E1 packet voice trunk network module (NM-HDV) • Fast Ethernet network module (NM-2W)
1- to 4-port T1/E1 Data and Digital Voice over an ATM Network	Cisco 2600 series, Cisco 3660, and Cisco 3700 series	AIM-ATM-VOICE-30	Multiflex trunk VWIC (VWIC-1MFT, for example) in one of the following: <ul style="list-style-type: none"> • WIC slot • Digital T1/E1 packet voice trunk network module (NM-HDV) • Fast Ethernet network module (NM-2W)
1- to 4-port T1/E1 Data and Digital Voice over an ATM Network	Cisco 3660 ¹ and Cisco 3700 series	AIM-ATM-VOICE-30	Multiflex trunk VWIC (VWIC-1MFT, for example) in one of the following: <ul style="list-style-type: none"> • Digital T1/E1 packet voice trunk network module (NM-HDV) • Fast Ethernet network module (NM-2W, NM-1FE, or NM-2FE)
Digital Voice	Cisco 3660 ¹ and Cisco 3700 series	AIM-VOICE-30	Multiflex trunk VWIC (VWIC-1MFT, for example) in a Fast Ethernet network module (NM-2W, NM-1FE, or NM-2FE)
Digital Voice	Cisco 2600 series, Cisco 3660, and Cisco 3700 series	AIM-VOICE-30	Multiflex trunk VWIC (VWIC-1MFT, for example) in one of the following: <ul style="list-style-type: none"> • WIC slot • Fast Ethernet network module (NM-2W)

1. Cisco 3660 routers also require multiservice interchange (MIX) modules (MIX-3660-64) installed for use of AIMS.

Related Features and Technologies

- [Enhanced ITU-T Echo Cancellation](#)
- Voice over IP
- Voice over ATM and Inverse Multiplexing over ATM
- Voice over Frame Relay

Configuration Tasks

See the following sections for configuration tasks for the AIM-ATM, AIM-VOICE-30, and AIM-ATM-VOICE-30 on the Cisco 2600 series, Cisco 3660, and Cisco 3700 series feature. Each task in the list indicates if the task is required or optional.

- [Configuring Network Clock Source and Participation](#) (Required for all AIMS)
- [Configuring AIM for ATM WAN Access](#) (Required for AIM-ATM or AIM-ATM-VOICE-30)
- [Configuring AIM for ATM WAN Access with IMA](#) (Optional for AIM-ATM or AIM-ATM-VOICE-30)
- [Configuring AIM DSP Functionality for VoIP, VoATM, or VoFR](#) (Required for AIM-VOICE-30 or AIM-ATM-VOICE-30)

Configuring Network Clock Source and Participation

Packet voice and video are sensitive to time delays. To prevent mismatches and data slips, you must synchronize data flows to a single clock source, known as the *network clock*. When a network clock is configured on a gateway, the router externally clocks one T1 or E1 port, and then passes that clock signal across the backplane to another T1 or E1 port on another WIC or network module slot. Use of a network clock on a gateway is configured by naming the network modules and interface cards that are participating in network clocking, and then selecting a port to act as the source of timing for the network clock.

The network clock provides timing from the source through the port to the AIM, and then out to all participating router slots. Cisco 2600 series routers support one internal AIM slot, and Cisco 3660 or Cisco 3700 series support two internal AIM slots. An AIM slot connects to both the main system bus and a secondary time-division multiplexing (TDM) bus running between network module slots and, on the Cisco 2600 series, to WAN interface card (WIC) slots.

**Note**

The clock configuration commands discussed in this section apply to ATM trunks as well as to digital voice trunks.

Three commands configure network clocking: **network-clock-participate**, **network-clock-select**, and **clock source** (digital ports only).

The **network-clock-participate** command configures the specified router slot to take its clock from the network clock; that is, this command identifies the slots that get their timing from the AIM.

The **network-clock-select** command configures a port in one of the participating slots to be a source for the network clock, and assigns it a priority level. This command is repeated for each port that you want to act as a primary or backup source for the network clock.

If the network clock source must be derived from an external source, either from the PSTN or PBX clocks over trunk lines, use the **network-clock-select** command. The highest priority level indicates the port that you want to be the primary source of timing for the network clock. If the highest-priority port becomes unavailable, the second-highest priority level takes over automatically as the network clock, and so forth for the lower-priority levels. The clocking is provided to the AIM, which then provides it to participating slots in the router.

For digital voice ports, the **clock source** command in controller configuration mode configures the type of timing (internal or from the line) for each port that you designate as a primary source or backup for the network clock. This step does not apply to analog voice ports.

These commands allow maximum flexibility. For example, on a router with a multiflex trunk VWIC connected to an ATM network and a digital T1/E1 packet voice trunk network module connected to a PBX, you could set up network clocking in any of three ways:

- The multiflex trunk VWIC provides clocking to the AIM, which provides it to the digital T1/E1 packet voice trunk network module (that is, to the PBX).
- The digital T1/E1 packet voice trunk network module provides clocking to the AIM, which provides it to the multiflex trunk VWIC (that is, to the ATM network).
- The ATM network and the PBX run their own clocks, which are not necessarily synchronized. However, this scenario could result in poor voice quality.

For a detailed discussion of clock sources on individual ports, see “Clock Sources on Digital T1/E1 Voice Ports” in the “[Configuring Voice Ports](#)” chapter in the *Cisco IOS Voice, Video, and Fax Configuration Guide*, Release 12.2.



Note

For analog ports using an AIM-ATM to process voice for ATM and AAL5, configure the network clock commands to select the controller port that is being used as the ATM trunk interface, so that the AIM-ATM is synchronized with the ATM network.

Configuring Clock Source Internal

If you are configuring a clock with an internal source, follow these steps.

SUMMARY STEPS

1. **enable**
2. **configure terminal**
3. **controller t1 slot/port**
4. **clock source {line [primary] | internal}**
5. **exit**
6. **network-clock-participate [slot slot | wic wic-slot | aim aim-slot-number]**
7. **exit**

DETAILED STEPS

	Command or Action	Purpose
Step 1	enable Example: Router> enable	Enables higher privilege levels, such as privileged EXEC mode. • Enter your password if prompted.
Step 2	configure terminal Example: Router# configure terminal	Enters global configuration mode.

	Command or Action	Purpose
Step 3	<pre>controller t1 slot/port</pre> <p>Example: Router(config)# controller t1 1/0 </p>	Enters controller configuration mode on the T1 or E1 controller on the selected slot and port.
Step 4	<pre>clock source {line [primary] internal}</pre> <p>Example: Router(config-controller)# clock source internal</p>	<p>Specifies the source from which the PLL on this port derives its clocking, and if the source is from the line, whether this port is the primary source. The default is line.</p> <ul style="list-style-type: none"> The primary keyword specifies that the PLL on this port derives its clocking from the external source to which the port is connected. This option also puts a second port, which is generally connected to the private branch exchange (PBX), into looped-time mode. Both ports are configured with line, but only the port connected to the external source is configured with primary. The internal keyword specifies that the clock is generated from the T1 or E1 controller internal PLL. <p>Note If you accept the default, the clock source configuration does not appear in the show running-config command output. Use the show controller command to display the current clock source for a port.</p>
Step 5	<pre>exit</pre> <p>Example: Router(config-controller)# exit </p>	Returns to global configuration mode.
Step 6	<pre>network-clock-participate [slot slot-number wic wic-slot aim aim-slot-number]</pre> <p>Example: Router(config)# network-clock-participate wic 0</p> <p>Example: Router(config)# network-clock-participate slot 5</p> <p>Example: Router(config)# network-clock-participate wic 0</p> <p>Example: Router(config)# network-clock-participate aim 0</p>	<p>Allows the network module or VWIC in the specified slot to use the network clock for its timing.</p> <ul style="list-style-type: none"> The keywords you select depend on the platform you are using. See the examples in the network-clock-participate command reference for more information.
Step 7	<pre>exit</pre> <p>Example: Router(config)# exit </p>	Exits global configuration mode and completes the network clock source and participation configuration.

Configuring Clock Source Line

If you are configuring a clock with a line source, follow these steps.

SUMMARY STEPS

1. **enable**
2. **configure terminal**
3. **controller t1 slot/port**
4. **clock source {line [primary] | internal}**
5. **mode atm aim**
Or
mode cas
Or
ds0-group ds0-group timeslots timeslot-list type {e&m-immediate | e&m-delay | e&m-wink | fxs-ground-start | fxs-loop-start | fxo-ground-start | fxo-loop-start}
Or
pri-group timeslots timeslot-list
6. **exit**
7. **network-clock-participate [slot slot | wic wic-slot | aim aim-slot-number]**
8. **network-clock-select priority {t1 | e1} slot/port**
9. **exit**

DETAILED STEPS

	Command or Action	Purpose
Step 1	enable Example: Router> enable	Enables privileged EXEC mode. <ul style="list-style-type: none">• Enter your password if prompted.
Step 2	configure terminal Example: Router# configure terminal	Enters global configuration mode.
Step 3	controller t1 slot/port Example: Router(config)# controller t1 1/0	Enters controller configuration mode on the T1 or E1 controller on the selected slot and port.

Command or Action	Purpose
<p>Step 4 <code>clock source {line [primary] internal}</code></p> <p>Example: Router(config-controller)# clock source line</p>	<p>Specifies the source from which the PLL on this port derives its clocking, and if the source is from the line, whether this port is the primary source. The default is line.</p> <ul style="list-style-type: none"> • The primary keyword specifies that the PLL on this port derives its clocking from the external source to which the port is connected. This option also puts a second port, which is generally connected to the private branch exchange (PBX), into looped-time mode. Both ports are configured with line, but only the port connected to the external source is configured with primary. • The internal keyword specifies that the clock is generated from the T1 or E1 controller internal PLL. <p>Note If you accept the default, the clock source configuration does not appear in the show running-config command output. Use the show controller command to display the current clock source for a port.</p>

Command or Action	Purpose
<p>Step 5</p> <pre>mode atm [aim aim-slot-number]</pre> <p>Or</p> <pre>mode cas</pre> <p>Or</p> <pre>ds0-group ds0-group timeslots timeslot-list type {e&m-immediate e&m-delay e&m-wink fxs-ground-start fxs-loop-start fxo-ground-start fxo-loop-start}</pre> <p>Or</p> <pre>pri-group timeslots timeslot-list</pre> <p>Example: Router(config-controller)# mode atm aim aim-slot-number</p> <p>Example: Router(config-controller)# mode cas</p> <p>Example: Router(config-controller)# ds0-group ds0-group timeslots timeslot-list type fxs-loop-start</p> <p>Example: Router(config-controller)# pri-group timeslots timeslot-list</p>	<p>Specifies that the configuration on this controller is for ATM, using the AIM in the specified slot for ATM processing, and creates ATM interface 0.</p> <ul style="list-style-type: none"> The <i>aim-slot</i> argument is the AIM slot number on the router chassis: <ul style="list-style-type: none"> Cisco 2600 series—0 Cisco 3660 and Cisco 3700 series—0 or 1 <p>Note The mode atm command without the aim keyword uses software to perform ATM SAR rather than the AIM. This is supported on Cisco 2600 series WIC slots only and is not supported on network module slots.</p> <ul style="list-style-type: none"> If you are configuring CAS for PRI rather than ATM, use the mode cas command, which specifies CAS mode for software images before Cisco IOS Release 12.2(15)T. <ul style="list-style-type: none"> Required only for Cisco 2600 series routers when configuring the ds0-group command and using WIC slots; not used on the Cisco 3660 or on Cisco 2600 series routers using network modules. If you are configuring DS0 groups, use the ds0-group command, which defines the T1 or E1 channels for use by compressed voice calls and the signaling method that the router uses to connect to the private branch exchange (PBX) or central office (CO). If you are configuring PRI groups instead of DS0 groups, use the pri-group command, which specifies an ISDN PRI on a channelized T1 or E1 controller. <p>Note When configuring PRI groups, you must also configure the isdn switch-type command. Also, only one PRI group can be configured on a controller.</p>
<p>Step 6</p> <pre>exit</pre> <p>Example: Router(config-controller)# exit</p>	<p>Exits controller configuration mode.</p>
<p>Step 7</p> <pre>network-clock-participate [slot slot-number wic wic-slot aim aim-slot-number]</pre> <p>Example: Router(config)# network-clock-participate wic 0</p> <p>Example: Router(config)# network-clock-participate slot 5</p>	<p>Allows the network module or VWIC in the specified slot to use the network clock for its timing.</p> <ul style="list-style-type: none"> The keywords you select depend on the platform you are using. See the network-clock-participate command reference for more information.

	Command or Action	Purpose
Step 8	<pre>network-clock-select priority {t1 e1} slot/port</pre> <p>Example: Router(config)# network-clock-select 1 e1 0/1</p>	<p>Specifies a port to be used as a timing source for the network clock and the priority level for the use of that port. The source that is given the highest priority is used first; if it becomes unavailable, the source with the second-highest priority is used, and so forth.</p> <ul style="list-style-type: none"> • This command is required if the clock source is from the line • The <i>priority</i> argument selects the priority for the clock source (1 is highest priority). • The t1 and e1 keywords specify the T1 or E1 ports. • The <i>slot</i> argument represents the slot number that identifies the controller clock source. <ul style="list-style-type: none"> – Cisco 2600 series and Cisco 2600XM—0 (built-in WIC slot) or 1 (network module slot). – Cisco 3660—1 to 6 – Cisco 3725 and Cisco 3745—1 to 4. • The <i>port</i> argument represents the port number that identifies the controller clock source. The range is from 0 to 3.
Step 9	<pre>exit</pre> <p>Example: Router(config)# exit</p>	<p>Exits global configuration mode and completes the network clock source and participation configuration.</p>

Configuring AIM for ATM WAN Access

For each controller that uses the ATM functionality of AIM-ATM or AIM-ATM-VOICE-30, the following must be configured:

- The AIM resources to be used—The **mode atm** command specifies the AIM to use for this controller.
- Voice over ATM, Voice over IP, or Voice over Frame Relay—See the appropriate document from the [“Related Documents” section on page 34](#).

To configure a controller to use an AIM for ATM processing for Voice over ATM, complete these steps.

SUMMARY STEPS

1. **enable**
2. **configure terminal**
3. **controller {t1 | e1} slot/port**
4. **mode atm [aim aim-slot-number]**
5. **exit**

DETAILED STEPS

	Command	Purpose
Step 1	enable Example: Router> enable	Enables higher privilege levels, such as privileged EXEC mode. <ul style="list-style-type: none"> Enter your password if prompted.
Step 2	configure terminal Example: Router# configure terminal	Enters global configuration mode.
Step 3	controller {t1 e1} slot/port Example: Router(config)# controller t1 slot/port	Enters controller configuration mode. The keywords and arguments are as follows: <ul style="list-style-type: none"> t1 e1—The type of controller. <i>slot/port</i>—The backplane slot number and port number for the interface being configured.
Step 4	mode atm [aim aim-slot-number] Example: Router(config-controller)# mode atm aim aim-slot-number	Specifies that the configuration on this controller is for ATM, using the AIM in the specified slot for ATM processing, and creates ATM interface 0. <i>aim-slot</i> is the AIM slot number on the router chassis: <ul style="list-style-type: none"> Cisco 2600 series—0 Cisco 3660 and Cisco 3700 series—0 or 1 <p>Note The mode atm command without the aim keyword uses software to perform ATM SAR rather than the AIM. This is supported on Cisco 2600 series WIC slots only, and is not supported on network module slots.</p>
Step 5	exit Example: Router(config-controller)# exit	Exits controller configuration mode.

Configuring AIM for ATM WAN Access with IMA

Inverse multiplexing over ATM allows you to aggregate multiple low-speed links into one larger virtual trunk, or IMA group, which appears to your ATM switch as one logical pipe. Configuration of IMA groups is described in the “Configuring Inverse Multiplexing over ATM” section of the “Configuring ATM” chapter of the *Cisco IOS Wide-Area Networking Configuration Guide*, Release 12.2.

When IMA is being configured on Cisco 2600 series and Cisco 3600 routers that use AIMS for ATM processing, the argument for **atm slot-number** in the **interface** command is different than when configuring ATM without an AIM. When using an AIM, the ATM slot number is always 0, because the

ATM resources are on the AIM in the motherboard rather than on a network module. All other ATM IMA commands are the same as those described in the “Configuring ATM” chapter of the *Cisco IOS Wide-Area Networking Configuration Guide*, Release 12.2.

To configure the interface for ATM IMA using an AIM-ATM or AIM-ATM-VOICE-30, complete the following steps.

SUMMARY STEPS

1. **enable**
2. **configure terminal**
3. **interface atm slot-number/ima group-number**
4. Configure IMA
5. **exit**

DETAILED STEPS

	Command	Purpose
Step 1	enable Example: Router> enable	Enables higher privilege levels, such as privileged EXEC mode. <ul style="list-style-type: none"> • Enter your password if prompted.
Step 2	configure terminal Example: Router# configure terminal	Enters global configuration mode.
Step 3	interface atm slot-number/ima group-number Example: Router(config)# interface atm slot-number/ima group-number	Enters interface configuration mode and specifies the slot location of the interface and IMA group number. Note atm slot-number is always 0 when configuring IMA and using an AIM for ATM processing on Cisco 2600 series, Cisco 3660, and Cisco 3700 series routers. There are no changes to other ATM interface commands.
Step 4	Configure IMA.	Continue with the IMA configuration described in the “Configuring Inverse Multiplexing over ATM” section of the “Configuring ATM” chapter of the <i>Cisco IOS Wide-Area Networking Configuration Guide</i> , Release 12.2.
Step 5	exit Example: Router(config-if)# exit	Exits interface configuration mode.

Configuring AIM DSP Functionality for VoIP, VoATM, or VoFR

For each controller that uses the DSP functionality of the AIM-VOICE-30 or AIM-ATM-VOICE-30, the following must be configured:

- The AIM DSP resources to be used—Use the **dspfarm** command in voice-card configuration mode assign resources.
- The controller mode to be used (only for Cisco 2600 series using WIC slots)—Use the **mode cas** command to specify that channel-associated signaling is used for this controller.
- Voice over ATM, Voice over IP, or Voice over Frame Relay—See the appropriate document from the “[Related Documents](#)” section on page 34.

DSPs contain specialized electronics to handle the complex computational processing needed for VoIP, such as compression, coding, and decoding. The number of DSP resources required on a router depends on the codec complexity and number of time slots you are using.

Previously, DSP resources required for voice processing had to be present on the same network module with the voice port. The **dspfarm** command now allows the DSP resources on an AIM-VOICE-30 or AIM-ATM-VOICE-30 to be mapped to a T1 or E1 connection housed in a network module or Cisco 2600 series WIC slot with no local DSPs.

Configure the use of AIM DSP resources by completing these steps.

SUMMARY STEPS

1. **enable**
2. **configure terminal**
3. **voice-card** *slot*
4. **dspfarm**
5. **exit**
6. **controller** {**t1** | **e1**} *slot/port*
7. **mode cas**
8. **ds0-group** *ds0-group* **timeslots** *timeslot-list* **type** {**e&m-immediate** | **e&m-delay** | **e&m-wink** | **fxs-ground-start** | **fxs-loop-start** | **fxo-ground-start** | **fxo-loop-start**}
- Or
9. **pri-group** **timeslots** *timeslot-list*
10. **exit**

DETAILED STEPS

	Command	Purpose
Step 1	enable Example: Router> enable	Enables higher privilege levels, such as privileged EXEC mode. <ul style="list-style-type: none"> Enter your password if prompted.
Step 2	configure terminal Example: Router# configure terminal	Enters global configuration mode.
Step 3	voice-card slot Example: Router(config)# voice-card slot	Enters voice-card configuration mode to configure DSP resources on the specified card. <i>slot</i> is the AIM slot number on the router chassis: <ul style="list-style-type: none"> Cisco 2600 series—0 for the AIM slot, 1 for the network module slot Cisco 2691—0 or 2 Cisco 3660—7 is AIM slot 0, and 8 is AIM slot 1 Cisco 3725—3 or 4 Cisco 3745—5 or 6
Step 4	dspfarm Example: Router(config-voicecard)# dspfarm	(Optional) Enters the DSP resources on the AIM specified in the voice-card command into the DSP resource pool.
Step 5	exit Example: Router(config-voicecard)# exit	Exits voice-card configuration mode.
Step 6	controller {t1 e1} slot/port Example: Router(config)# controller {t1 e1} slot/port	Enters controller configuration mode. The keywords and arguments are as follows: <ul style="list-style-type: none"> t1 e1—The type of controller. <i>slot/port</i>—The backplane slot number and port number for the interface being configured.

	Command	Purpose
Step 7	<p>mode cas</p> <p>Example: Router(config-controller)# mode cas</p>	<p>Specifies CAS mode for software images before Cisco IOS Release 12.2(15)T.</p> <ul style="list-style-type: none"> Required only for Cisco 2600 series routers when configuring the ds0-group command and using WIC slots; not used on the Cisco 3660 or on Cisco 2600 series routers using network modules. Use the mode ccs command for PRI configurations.
Step 8	<p>ds0-group ds0-group timeslots timeslot-list type {e&m-immediate e&m-delay e&m-wink fxs-ground-start fxs-loop-start fxo-ground-start fxo-loop-start}</p> <p>Example: Router(config-controller)# ds0-group ds0-group timeslots timeslot-list type fxs-loop-start</p> <p>Or</p> <p>Router(config-controller)# pri-group timeslots timeslot-list</p> <p>Example: Router(config-controller)# pri-group timeslots timeslot-list</p>	<p>Defines the T1 or E1 channels for use by compressed voice calls and the signaling method that the router uses to connect to the private branch exchange (PBX) or central office (CO).</p> <p>Or</p> <p>Specifies an ISDN Primary Rate Interface (PRI) on a channelized T1 or E1 controller.</p> <p>Note When configuring PRI groups, you must also configure the isdn switch-type command. Also, only one PRI group can be configured on a controller.</p>
Step 9	<p>exit</p> <p>Example: Router(config-controller)# exit</p>	<p>Exits controller configuration mode.</p>

Verifying AIM Configuration

Use the following commands to verify your software configuration:

- Verify the running configuration with the **show running-config** command.
- Verify controller information to verify the clock source configuration with the **show controller** command.
- Verify the current chosen clock and the list of all sources of network clocks according to their priority with the show network-clock command:

```
Router# show network-clocks
```

```
Network Clock Configuration
```

```
-----
```

Priority	Clock Source	Clock State	Clock Type
3	E1 6/2	GOOD	E1
5	T1 2/0	GOOD	T1
9	Backplane	Good	PLL

```
Current Primary Clock Source
```

```

-----
Priority      Clock Source      Clock State      Clock Type
-----
3            E1 6/2            GOOD             E1

```

Troubleshooting Tips

The following commands verify hardware in the router:

- **show version**—Lists the modules installed in the router. If AIMS are installed, the output displays one of the following:

1 ATM AIM(s)—If one AIM is installed in the router

2 ATM AIM(s)—If two AIMS are installed in the router

- **show pci aim**—(Cisco 2600 series only) Lists AIMS installed in Cisco 2600 series routers.

The following example shows one AIM-ATM in a Cisco 2600 series router:

```

Router# show pci aim
AIM Slot 0:ID 0x01B0
  Hardware Revision      :1.0
  Top Assy. Part Number  :800-03700-01
  Board Revision        :A0
  Deviation Number      :0-0
  Fab Version           :02
  PCB Serial Number     :JAB9801ABCD
  RMA Test History      :00
  RMA Number            :0-0-0-0
  RMA History           :00
  EEPROM format version 4
  EEPROM contents (hex):
    0x00:04 FF 40 01 B0 41 01 00 C0 46 03 20 00 0E 74 01
    0x10:42 41 30 80 00 00 00 00 02 02 C1 8B 4A 41 42 39
    0x20:38 30 31 41 42 43 44 03 00 81 00 00 00 00 04 00
    0x30:FF FF FF FF FF FF FF FF FF FF FF FF FF FF FF
    0x40:FF FF FF FF FF FF FF FF FF FF FF FF FF FF FF
    0x50:FF FF FF FF FF FF FF FF FF FF FF FF FF FF FF
    0x60:FF FF FF FF FF FF FF FF FF FF FF FF FF FF FF
    0x70:FF FF FF FF FF FF FF FF FF FF FF FF FF FF FF

```

- **show diag**—Lists the onboard port adapters in the system board (slot 0 of the router). (AIM slots are in the system board.) The AIM information is at the end of the list. The following example shows one AIM-ATM in a Cisco 2600 series router:

```

Router# show diag 0

Slot 0:
C2621 2FE Mainboard Port adapter, 4 ports
Port adapter is analyzed
Port adapter insertion time unknown
EEPROM contents at hardware discovery:
Hardware Revision      : 1.0
PCB Serial Number     : JAB030805D4 (1437466844)
Part Number           : 73-3200-03
RMA History           : 00
RMA Number            : 0-0-0-0
Board Revision        : A0
Deviation Number      : 0-0
EEPROM format version 4
EEPROM contents (hex):
  0x00: 04 FF 40 00 A2 41 01 00 C1 18 4A 41 42 30 33 30
  0x10: 38 30 35 44 34 20 28 31 34 33 37 34 36 36 38 34

```

```

0x20: 34 29 82 49 0C 80 03 04 00 81 00 00 00 00 42 41
0x30: 30 80 00 00 00 00 FF FF FF FF FF FF FF FF FF
0x40: FF FF FF FF FF FF FF FF FF FF FF FF FF FF FF
0x50: FF FF FF FF FF FF FF FF FF FF FF FF FF FF FF
0x60: FF FF FF FF FF FF FF FF FF FF FF FF FF FF FF
0x70: FF FF FF FF FF FF FF FF FF FF FF FF FF FF FF
    
```

WIC Slot 0:

```

T1 (2 port) WAN daughter card
Hardware revision 1.0          Board revision B0
Serial number 18050118        Part number 800-04477-01
Test history 0x0              RMA number 00-00-00
Connector type PCI
EEPROM format version 1
EEPROM contents (hex):
  0x20: 01 22 01 00 01 13 6C 46 50 11 7D 01 00 00 00 00
  0x30: 58 00 00 00 00 02 21 00 FF FF FF FF FF FF FF FF
    
```

WIC Slot 1:

```

E1 Drop&Insert (2 port) WAN daughter card
Hardware revision 1.0          Board revision B0
Serial number 24234788        Part number 800-04615-02
Test history 0x0              RMA number 00-00-00
Connector type PCI
EEPROM format version 1
EEPROM contents (hex):
  0x20: 01 25 01 00 01 71 CB 24 50 12 07 02 00 00 00 00
  0x30: 58 00 00 00 00 12 19 00 FF FF FF FF FF FF FF FF
    
```

ATM AIM

```

ATM AIM module with SAR only (no DSPs)
Hardware Revision :1.0
Top Assy. Part Number :800-03700-01
Board Revision :A0
Deviation Number :0-0
Fab Version :02
PCB Serial Number :JAB9801ABCD
RMA Test History :00
RMA Number :0-0-0-0
RMA History :00
EEPROM format version 4
EEPROM contents (hex):
  0x00:04 FF 40 01 B0 41 01 00 C0 46 03 20 00 0E 74 01
  0x10:42 41 30 80 00 00 00 00 02 02 C1 8B 4A 41 42 39
  0x20:38 30 31 41 42 43 44 03 00 81 00 00 00 00 04 00
  0x30:FF FF FF FF FF FF FF FF FF FF FF FF FF FF FF
  0x40:FF FF FF FF FF FF FF FF FF FF FF FF FF FF FF
  0x50:FF FF FF FF FF FF FF FF FF FF FF FF FF FF FF
  0x60:FF FF FF FF FF FF FF FF FF FF FF FF FF FF FF
  0x70:FF FF FF FF FF FF FF FF FF FF FF FF FF FF FF
    
```

The following example shows one AIM-ATM in a Cisco 3660 router:

```

Router# show diag 0

3660 Chassis type: ENTERPRISE

c3600 Backplane EEPROM:
.
.
.
Backplane TDM Switch :
  Hardware Revision      : 1.0
  Top Assy. Part Number  : 800-03700-01
    
```

```

Board Revision          : A0
Deviation Number       : 0-0
Fab Version            : 02
PCB Serial Number      : JAB9801ABCD
RMA Test History       : 00
RMA Number             : 0-0-0-0
RMA History            : 00
EEPROM format version 4
EEPROM contents (hex):
 0x00: 04 FF 40 01 E1 41 01 00 C0 46 03 20 00 0E 74 01
 0x10: 42 41 30 80 00 00 00 00 02 02 C1 8B 4A 41 42 39
 0x20: 38 30 31 41 42 43 44 03 00 81 00 00 00 00 04 00
 0x30: FF FF FF FF FF FF FF FF FF FF FF FF FF FF FF FF
Slot 0:
  C3600 Mother board 2FE(TX) Port adapter, 2 ports
  .
  .
  .
ATM AIM: 1
ATM AIM module with SAR only (no DSPs)
Hardware Revision      : 1.0
Top Assy. Part Number  : 800-03700-01
Board Revision         : A0
Deviation Number       : 0-0
Fab Version            : 02
PCB Serial Number      : JAB9801ABCD
RMA Test History       : 00
RMA Number             : 0-0-0-0
RMA History            : 00
EEPROM format version 4
EEPROM contents (hex):
 0x00: 04 FF 40 01 B0 41 01 00 C0 46 03 20 00 0E 74 01
 0x10: 42 41 30 80 00 00 00 00 02 02 C1 8B 4A 41 42 39
 0x20: 38 30 31 41 42 43 44 03 00 81 00 00 00 00 04 00
 0x30: FF FF FF FF FF FF FF FF FF FF FF FF FF FF FF FF
 0x40: FF FF FF FF FF FF FF FF FF FF FF FF FF FF FF FF
 0x50: FF FF FF FF FF FF FF FF FF FF FF FF FF FF FF FF
 0x60: FF FF FF FF FF FF FF FF FF FF FF FF FF FF FF FF
 0x70: FF FF FF FF FF FF FF FF FF FF FF FF FF FF FF FF

```

Configuration Examples

This section provides the following configuration examples:

- [ATM AIM for ATM with IMA Configuration Example, page 30](#)
- [AIM DSP for VoIP Configuration Example, page 31](#)



Note

IP addresses and host names in these examples are fictitious.

```

!
interface ATM0/1
 ip address 10.0.1.1 255.0.0.0
 scrambling-payload
 ima-group 1
 no atm ilmi-keepalive
 pvc 1/20
  protocol ip 10.0.1.2 broadcast
!
!
interface ATM0/IMA1
 ip address 172.20.0.1 255.0.0.0
 no atm ilmi-keepalive
 pvc 1/100
  protocol ip 172.20.0.2 broadcast
!
!
ip classless
ip route 192.168.254.254 255.255.255.255 Ethernet0/0
no ip http server
!
!
!
snmp-server packetsize 4096
call rsvp-sync
!
mgcp modem passthrough voip mode ca
no mgcp timer receive-rtcp
!
mgcp profile default
!
dial-peer cor custom
!
!
!
!
line con 0
 transport input none
line aux 0
line vty 0 4
 login
!
end

```

AIM DSP for VoIP Configuration Example

The following example uses the DSP capabilities of the AIM-VOICE-30 to process voice and then take the voice out over the Ethernet connection on a Cisco 2600 series gateway.

```

version 12.2
no service single-slot-reload-enable
no service pad
service timestamps debug datetime msec
service timestamps log datetime msec
no service password-encryption
!
hostname 2600b
!
no logging buffered
no logging buffered
logging rate-limit console 10 except errors
!

```

```

!
!
!
memory-size iomem 30
network-clock-participate wic 0
network-clock-select 2 E1 0/1
voice-card 0
  dspfarm
!
ip subnet-zero
!
!
no ip finger
ip host monroe 192.168.254.254
!
isdn switch-type primary-qsig
!
!
!
!
controller E1 0/0
  clock source internal
  pri-group timeslots 1-31
!
controller E1 0/1
  mode atm aim 0
!
controller T1 1/0
!
controller T1 1/1
!
!
!
interface Loopback0
  ip address 10.0.0.1 255.0.0.0
  no ip mroute-cache
!
interface Ethernet0/0
  ip address 10.8.10.26 255.255.255.0
  half-duplex
!
interface Serial0/0:15
  no ip address
  ip mtu 0
  no logging event link-status
  isdn switch-type primary-qsig
  isdn incoming-voice voice
  no cdp enable
!
interface ATM0/1
  ip address 10.0.0.1 255.255.255.0
  scrambling-payload
  no atm ilmi-keepalive
  pvc 10/10
    protocol ip 10.0.0.2 broadcast
!
!
interface Ethernet0/1
  ip address 172.24.63.26 255.255.255.0
  half-duplex
!
ip classless
ip route 10.3.26.0 255.255.255.0 1.4.0.1

```

```
ip route 10.3.26.0 255.255.255.0 1.5.0.1
ip route 192.168.0.0 255.255.0.0 1.4.0.1
ip route 192.168.254.0 255.255.255.0 Ethernet0/0
no ip http server
!
!
snmp-server engineID local 0000000902000001429F4180
snmp-server packetsize 4096
call rsvp-sync
!
voice-port 0/0:15
!
mgcp modem passthrough voip mode ca
no mgcp timer receive-rtcp
!
mgcp profile default
!
dial-peer cor custom
!
!
!
dial-peer voice 150 voip
 destination-pattern 3.....
 session target ipv4:172.24.63.2
 codec g711alaw
!
dial-peer voice 20 pots
 destination-pattern 2.....
 direct-inward-dial
 port 0/0:15
 forward-digits all
!
!
line con 0
 transport input none
line aux 0
line vty 0 4
 login
!
end
```

Additional References

For additional information related to the AIM-ATM, AIM-VOICE-30, and AIM-ATM-VOICE-30 on the Cisco 2600 Series, Cisco 3660, and Cisco 3700 Series feature, refer to the following references:

- [Related Documents, page 34](#)
- [Standards, page 34](#)
- [MIBs, page 35](#)
- [RFCs, page 35](#)
- [Technical Assistance, page 35](#)

Related Documents

Related Topic	Document Title
Installation of AIM modules	<i>Installing ATM and Voice-Compression Advanced Integration Modules in Cisco 2600 Series and Cisco 3660 Routers.</i>
Cisco IOS WAN commands and reference material	<i>Cisco IOS Wide-Area Networking Command Reference</i> , Release 12.2 T
Clock sources on individual ports	Configuring Voice Ports” chapter of the <i>Cisco IOS Voice, Video, and Fax Configuration Guide</i> , Release 12.2.
VoATM with AAL2 or AAL5 encapsulation	<i>Configuring AAL2 and AAL5 for the High-Performance Advanced Integration Module on the Cisco 2600 Series</i> , Cisco IOS Release 12.2(2)XA.
ATM and IMA for the Cisco 2600 series and Cisco 3660	<i>ATM Software Segmentation and Reassembly (SAR)</i> , Cisco IOS Release 12.2(2)XB.
Inverse Multiplexing over ATM (IMA)	Configuring ATM” chapter in the <i>Cisco IOS Wide-Area Networking Configuration Guide</i> , Release 12.2.
ISDN configuration	Configuring ISDN Interfaces for Voice” chapter in the <i>Cisco IOS Voice, Video, and Fax Configuration Guide</i> , Release 12.2.
Cisco IOS commands to support voice, video, and fax applications	<i>Cisco IOS Voice, Video, and Fax Command Reference</i> , Release 12.2 T
How to configure your Cisco router or access server to support voice, video, and fax applications	<i>Cisco IOS Voice, Video, and Fax Configuration Guide</i> , Release 12.2T
Cisco 2600 series	Cisco 2600 series routers documentation index on Cisco.com
Cisco 3600 series	Cisco 3600 series routers documentation index on Cisco.com
Cisco 3700 series	Cisco 3700 Series Routers documentation index on Cisco.com
How to configure the G.168 extended echo canceller	<i>Enhanced ITU-T Echo Cancellation</i>
How to configure the MIX module on the Cisco 3660	<i>Multiservice Interchange (MIX) for Cisco 2600 and 3600 Series Multiservice Platforms</i> , Release 12.2(4)T.

Standards

Standards	Title
No new or modified standards are supported by this feature, and support for existing standards has not been modified by this feature.	—

MIBs

MIBs	MIBs Link
No new or modified MIBs are supported by this feature, and support for existing MIBs has not been modified by this feature.	To obtain lists of supported MIBs by platform and Cisco IOS release, and to download MIB modules, go to the Cisco MIB website on Cisco.com at the following URL: http://www.cisco.com/public/sw-center/netmgmt/cmtk/mibs.shtml

To locate and download MIBs for selected platforms, Cisco IOS releases, and feature sets, use Cisco MIB Locator found at the following URL:

<http://tools.cisco.com/ITDIT/MIBS/servlet/index>

If Cisco MIB Locator does not support the MIB information that you need, you can also obtain a list of supported MIBs and download MIBs from the Cisco MIBs page at the following URL:

<http://www.cisco.com/public/sw-center/netmgmt/cmtk/mibs.shtml>

To access Cisco MIB Locator, you must have an account on Cisco.com. If you have forgotten or lost your account information, send a blank e-mail to cco-locksmith@cisco.com. An automatic check will verify that your e-mail address is registered with Cisco.com. If the check is successful, account details with a new random password will be e-mailed to you. Qualified users can establish an account on Cisco.com by following the directions found at this URL:

<http://www.cisco.com/register>

RFCs

RFCs	Title
No new or modified RFCs are supported by this feature, and support for existing RFCs has not been modified by this feature.	—

Technical Assistance

Description	Link
Technical Assistance Center (TAC) home page, containing 30,000 pages of searchable technical content, including links to products, technologies, solutions, technical tips, and tools. Registered Cisco.com users can log in from this page to access even more content.	http://www.cisco.com/public/support/tac/home.shtml

Command Reference

This section documents modified commands. All other commands used with this feature are documented in the Cisco IOS Release 12.2 command reference publications.

- [clock source \(T1/E1 controller\)](#)

- **dspfarm (voice-card)**
- **mode (T1/E1 controller)**
- **network-clock-participate**
- **network-clock-select**
- **voice-card**

clock source (T1/E1 controller)

To set clocking for individual T1 or E1 links, use the **clock source** command in controller configuration mode. To return to the default, use the **no** form of this command.

```
clock source {line [primary] | internal | free-running}
```

```
no clock source
```

Syntax Description	line	primary	internal	free-running
	Specifies that the phase-locked loop (PLL) on this port derives its clocking from the external source to which the port is connected, which is generally the telephone company central office (CO).	Specifies that the PLL on this port derives its clocking from the external source to which the port is connected. This option also puts a second port, which is generally connected to the private branch exchange (PBX), into looped-time mode. Both ports are configured with line , but only the port connected to the external source is configured with primary .	Specifies that the clock is generated from the T1 or E1 controller's internal PLL.	Specifies a free-running clock derived from the oscillator on the motherboard, which is used only for testing and back-to-back connections.

Defaults The default is **line**.

Command Modes Controller configuration

Command History	Release	Modification
	12.2(2)XB	This command is supported in controller configuration mode for Cisco 2600 series and Cisco 3660 routers.
	12.2(8)T	This command was integrated into Cisco IOS Release 12.2(8)T.
	12.2(15)T	This command was implemented on the Cisco 2691 and the Cisco 3700 series.

Usage Guidelines For a detailed discussion of clock sources on individual ports, see “Clock Sources on Digital T1/E1 Voice Ports” in the “[Configuring Voice Ports](#)” chapter in the *Cisco IOS Voice, Video, and Fax Configuration Guide*, Release 12.2.

Examples The following example shows the router providing clock source to two controllers:

```
controller E1 1/0
 framing crc4
 linecoding hdb3
 clock source internal
```

clock source (T1/E1 controller)

```

ds0-group timeslots 1-15 type e&m-wink-start
!
controller E1 1/1
 framing esf
 linecoding b8zs
 clock source internal
 ds0-group timeslots 1-15 type e&m-wink-start

```

The following example shows the digital voice hardware receiving clocking for the PLL from E1 1/0, and using this clock as a reference to clock E1 1/1. If controller E1 1/0 fails, the PLL internally generates the clock reference to drive E1 1/1.

```

controller E1 1/0
 framing crc4
 linecoding hdb3
 clock source line
 ds0-group timeslots 1-15 type e&m-wink-start
!
controller E1 1/1
 framing crc4
 linecoding hdb3
 clock source internal
 ds0-group timeslots 1-15 type e&m-wink-start

```

Related Commands

Command	Description
controller	Configures a T1 or E1 controller and enters controller configuration mode.

dspfarm (voice-card)

To allow the specified voice card to participate in digital signal processor (DSP) resource mapping, use the **dspfarm** command in voice-card configuration mode. To remove the specified card from participation in the DSP resource map, use the **no** form of this command.

dspfarm

no dspfarm

Syntax Description

This command has no arguments or keywords.

Defaults

The default behavior is that a card participates in the DSP resource pool.

Command Modes

Voice-card configuration

Command History

Release	Modification
12.1(5)XM	This command was introduced for the Cisco 3660.
12.2(2)XB	Support was added for Cisco 2600 series routers.
12.2(8)T	This command was integrated into Cisco IOS Release 12.2(8)T.
12.2(15)T	This command was implemented on the Cisco 2691 and the Cisco 3700 series.

Usage Guidelines

DSP mapping occurs when DSP resources on one AIM or network module are available for processing of voice time-division multiplexing (TDM) streams on a different network module or on a voice/WAN interface card (VWIC). This command is used on Cisco 3660 with a multiservice interchange (MIX) module installed or on Cisco 2600 series routers with AIMS installed.

To reach voice-card configuration mode for a particular voice card, from global configuration mode enter the **voice-card** command and the slot number for the AIM or network module that you want to add to the pool. See the **voice-card** command reference for details on slot numbering.

The assignment of DSP pool resources to particular TDM streams is based on the order in which the streams are configured with the **ds0-group** command for T1/E1 channel-associated signaling (CAS) or the **pri-group** command for ISDN Primary Rate Interface (PRI). The assignment of DSP pool resources does not occur dynamically during call signaling.

Examples

The following example adds the DSP resources on the network module in slot 5 on a Cisco 3660 with a MIX module to the DSP resource map:

```
voice-card 5
 dspfarm
```

The following example makes available the DSP resources on an AIM on a Cisco 2600 series router:

■ dspfarm (voice-card)

```
voice-card 0
dspfarm
```

Related Commands

Command	Description
voice-card	Enters voice-card configuration mode.

mode (T1/E1 controller)

To set the T1 or E1 controller into ATM mode and create an ATM interface (ATM 0) or to set the T1 or E1 controller into channel-associated signaling (CAS) mode, use the **mode** command in controller configuration mode. To disable the controller mode, use the **no** form of this command.

```
mode { atm [aim aim-slot] | cas }
```

```
no mode { atm [aim aim-slot] | cas }
```

Syntax Description	
atm	<p>Sets the controller into ATM mode and creates an ATM interface (ATM 0). When ATM mode is enabled, no channel groups, DS0 groups, PRI groups, or TDM groups are allowed, because ATM occupies all the DS0s on the T1/E1 trunk.</p> <p>When you set the controller to ATM mode, the controller framing is automatically set to ESF for T1 or CRC4 for E1. The linecode is automatically set to B8ZS for T1 or HDLC for E1. When you remove ATM mode by entering the no mode atm command, ATM interface 0 is deleted.</p> <p>On the Cisco MC3810, ATM mode is supported only on controller 0 (T1 or E1 0).</p> <p>Note The mode atm command without the aim keyword uses software to perform ATM segmentation and reassembly (SAR). This is supported on Cisco 2600 series WIC slots only, and is not supported on network module slots.</p>
aim	Specifies that the configuration on this controller uses the Advanced Integration Module (AIM) in the specified slot for ATM SAR. The aim keyword does not apply to the Cisco MC3810.
<i>aim-slot</i>	<p>AIM slot number on the router chassis:</p> <ul style="list-style-type: none"> • Cisco 2600 series and Cisco 2600XM—0 • Cisco 3660—0 or 1 • Cisco 3700 series—0 or 1
cas	(Cisco 2600 series WIC slots only) Specifies that the T1 or E1 in this WIC slot is mapped to AIM DSPs to support T1 or E1 voice (that is, it is configured in a DS0 group or a PRI group).

Defaults No default behavior or values.

Command Modes Controller configuration

Command History

Release	Modification
11.3 MA	This command was introduced on the Cisco MC3810.
12.1(5)XM	Support for this command was extended to the merged SGCP/MGCP software.
12.2(2)T	This command was integrated into Cisco IOS Release 12.2(2)T.
12.2(2)XB	Support was extended to the Cisco 2600 series and Cisco 3660. The keyword aim and the argument <i>aim-slot</i> were added. The parenthetical modifier for the command was changed from “Voice over ATM” to “T1/E1 controller.”
12.2(8)T	This command was integrated into Cisco IOS Release 12.2(8)T.
12.2(15)T	This command was implemented on the Cisco 2691 and the Cisco 3700 series.

Usage Guidelines

This command has these platform-specific usage guidelines:

- Cisco 2600 series and Cisco 3660 or Cisco 3700 series that use an AIM for ATM processing must use the **mode atm aim** *aim-slot* command.
- Cisco 2600 series routers that use an AIM for DSP processing and specify DS0 groups must use the **mode cas** command if they are using WIC slots for voice. This command does not apply if network modules are being used.
- Cisco 3660 or Cisco 3700 series that use an AIM only for DSP resources should not use this command.
- On Cisco 2600 series routers that use WIC slots for voice, the **mode atm** command without the **aim** keyword specifies software ATM segmentation and reassembly. When the **aim** keyword is used with the **mode atm** command, the AIM performs ATM segmentation and reassembly.
- Cisco MC3810 routers cannot use the **aim** keyword.
- Cisco MC3810 routers with digital voice modules (DVM) use some DS0s exclusively for different signaling modes. The DS0 channels have the following limitations when mixing different applications (such as voice and data) on the same network trunk:
 - On E1 controllers, DS0 16 is used exclusively for either CAS or CCS, depending on which mode is configured.
 - On T1 controllers, DS0 24 is used exclusively for CCS.
- Cisco MC3810—When no mode is selected, channel groups and clear channels (data mode) can be created using the **channel group** and **tdm-group** commands, respectively.
- Cisco MC3810 is not supported in the AIM-ATM, AIM-VOICE-30, and AIM-ATM-VOICE-30 on the Cisco 2600 Series, Cisco 3660, and Cisco 3700 Series feature.

Examples

The following example configures ATM mode on controller T1 0. This step is required for Voice over ATM.

```
controller T1 0
 mode atm
```

The following example configures ATM mode on controller T1 1/0 on a Cisco 2600 series router, using an AIM in slot 0 for ATM segmentation and reassembly:

```
controller T1 1/0
mode atm aim 0
```

The following example configures CAS mode on controller T1 1 on a Cisco MC3810:

```
controller T1 1
mode cas
```

Related Commands	Command	Description
	channel-group	Defines the time slots of each T1 or E1 circuit.
	ds0-group	Defines T1/E1 channels for compressed voice calls and the CAS method by which the router connects to the private branch exchange (PBX) or public switched telephone network (PSTN).
	tdm-group	Configures a list of time slots for creating clear channel groups (pass-through) for time-division multiplexing (TDM) cross-connect.

network-clock-participate

To allow ports on a specified network module or voice/WAN interface card (VWIC) to use the network clock for timing, use the **network-clock-participate** command in global configuration mode. To restrict the device to use only its own clock signals, use the **no** form of this command.

network-clock-participate [**slot** *slot-number* | **wic** *wic-slot* | **aim** *aim-slot-number*]

no network-clock-participate [**slot** *slot-number* | **wic** *wic-slot* | **aim** *aim-slot-number*]

Syntax Description

slot <i>slot-number</i>	Network module slot number on the router chassis. The following are valid values: <ul style="list-style-type: none"> • Cisco 2600 series—1 • Cisco 3660—1 to 6 • Cisco 3700 series—1 to 4
wic <i>wic-slot</i>	<ul style="list-style-type: none"> • Configures the WAN interface card (WIC) slot number on the router chassis. The following are valid values: <ul style="list-style-type: none"> – Cisco 2600 series—0 and 1 – Cisco 3700 series—0 to 2
aim <i>aim-slot-number</i>	Configures the Advanced Integration Module (AIM) in the specified slot. The following are valid values: are 0 for the Cisco 2600 series and Cisco 2600 XM, 0 or 1 for the Cisco 3660, and 0 or 1 for the Cisco 3725, and Cisco 3745.

Defaults

No network clocking is enabled, and interfaces are restricted to using the clocking generated on their own modules.

Command Modes

Global configuration

Command History

Release	Modification
12.1(5)XM	This command was introduced on the Cisco 3660.
12.2(4)T	This command was integrated into Cisco IOS Release 12.2(4)T.
12.2(2)XB	This command was implemented on the Cisco 2600 series. The slot keyword was replaced by the nm keyword and the wic keyword and the <i>wic-slot</i> argument were added.
12.2(8)T	This command was integrated into Cisco IOS Release 12.2(8)T.
12.2(15)T	This command was implemented on the Cisco 2600XM, Cisco 2691, Cisco 3725, and Cisco 3745. The aim keyword was added. The nm keyword was replaced by the slot keyword.

Usage Guidelines

This command is used on the Cisco 2600 series or Cisco 2600XM with an AIM for ATM segmentation. This command is used on the Cisco 3660, Cisco 3725, and Cisco 3745 with reassembly or digital signal processing.

On the Cisco 3700 series, you must use the **network-clock-participate** command and either the **wic wic-slot** keyword and argument or the **slot slot-number** keyword and argument.

This command applies to any network module with T1/E1 controllers to provide clocks from a central source (AIM for the Cisco 2600 or MIX module for the Cisco 3660) to the network module and to the port on the network module. That port can be selected as the clock source with the **network-clock-select** command to supply clock resources to other ports or network modules that choose to participate in network clocking with the **network-clock-participate** command. This command synchronizes the clocks for two ports.

**Note**

If the AIM takes its clock signals from a T1 or E1 controller, it is mandatory to use the **network-clock-select** and **network-clock-participate** commands for ATM. The clocks for the ATM and voice interfaces do not need to be synchronous, but improved voice quality may result if they are.

**Note**

The only VWICs that can participate in network clocking are those found in Cisco 2600 series WIC slots, digital T1/E1 packet voice trunk network modules (NM-HDV), and Fast Ethernet network modules (NM-2W, NM-1FE, and NM-2FE).

**Note**

The **wic wic-slot** value is only available on the Cisco 2600 series, Cisco 2600XM, and Cisco 3700 series.

For the Cisco 2610, you must configure the WIC number; for the Cisco 3660, you must configure the slot number; and for the Cisco 2691, Cisco 3725, and Cisco 3745, you must configure the WIC and the AIM number.

Examples

The following example configures the network module in slot 5 to participate in network clocking on a Cisco 3660 with a MIX module:

```
network-clock-participate slot 5
network-clock-select 1 e1
```

The following example specifies that the AIM participates in network clocking and selects port E1 0/1 to provide the clock signals on a Cisco 3700 series router:

```
Router(config)# network-clock-participate wic 0
Router(config)# network-clock-participate aim 0
Router(config)# network-clock-select 2 E1 0/1
```

The following example specifies the slot number that participates in network clocking and selects port E1 5/0 on a Cisco 3660:

```
Router(config)# network-clock-participate slot 5
Router(config)# network-clock-select 1 E1 5/0
```

The following example specifies the WIC number that participates in network clocking and selects port E1 0/0 on a Cisco 2600 series router:

```
Router(config)# network-clock-participate wic 0
Router(config)# network-clock-select 1 E1 0/0
```

Related Commands	Command	Description
	network-clock-select	Configures the network clock source and priorities for providing timing to the system backplane time-division multiplexing (TDM) bus.
	network-clock-source	Selects the port to be the clock source to supply clock resources to other ports or network modules.

network-clock-select

To name a source that provides timing for the network clock and to specify the selection priority for this clock source, use the **network-clock-select** command in global configuration mode. To cancel the network clock selection, use the **no** form of this command.

Cisco 2600 series or Cisco 3660

```
network-clock-select priority {t1 | e1} slot /port
```

```
no network-clock-select priority {t1 | e1} slot/port
```

Cisco MC3810

```
network-clock-select priority {serial 0 | system | controller}
```

```
no network-clock-select priority {serial 0 | system | controller}
```



Note

The Cisco MC3810 is not supported with the AIM-ATM, AIM-VOICE-30, and AIM-ATM-VOICE-30 on the Cisco 2600 Series, Cisco 3660, and Cisco 3700 Series feature.

Syntax Description

<i>priority</i>	Selection priority for the clock source (1 is highest priority). The clock with highest priority will be selected to drive the system TDM clocks. When the higher priority clock source fails, the next higher priority clock source is selected. Values are: <ul style="list-style-type: none"> • Cisco 2600 series—1 to 4. • Cisco 3660—1 to 8. • Cisco MC3810—1 to 4.
t1	(Cisco 2600 series or Cisco 3660) Port type is T1.
e1	(Cisco 2600 series or Cisco 3660) Port type is E1.
<i>slot</i>	(Cisco 2600 series or Cisco 3660) Slot number identifying the controller that is the clock source. <ul style="list-style-type: none"> • Cisco 2600 series—0 (built-in WIC slot) or 1 (network module slot). • Cisco 3660—1 to 6.
<i>port</i>	(Cisco 2600 series or Cisco 3660) Port number identifying the controller that is the clock source. The range is from 0 to 3.
serial 0	(Cisco MC3810) (Optional) Specifies serial interface 0 as the clock source.
system	(Cisco MC3810) (Optional) Specifies the system clock as the clock source.
<i>controller</i>	(Cisco MC3810) (Optional) Specifies which controller is the clock source. You can specify either the trunk controller (T1/E1 0) or the digital voice module (T1/E1 1).

Defaults**Cisco 2600 series**

The network clock source is the Advanced Integration Module (AIM) phase-locked loop (PLL) with priority 5.

Cisco 3660

The network clock source is the backplane PLL with priority 9.

Cisco MC3810

No network clock source is specified.

Command Modes

Global configuration

Command History

Release	Modification
11.3 MA	This command was introduced for the Cisco MC3810.
12.1(5)XM	Support was added for the Cisco 3660, and the keywords t1 and e1 were introduced.
12.2(2)XB	Support was added for Cisco 2600 series and Cisco 3660 routers with Advanced Integration Modules (AIMs) installed.
12.2(8)T	This command was integrated into Cisco IOS Release 12.2(8)T.
12.2(15)T	This command was implemented on the Cisco 2691 and the Cisco 3700 series.

Usage Guidelines**Cisco 2600 series, Cisco 3660, and Cisco 3700 series**

This command is used on Cisco 2600 series, Cisco 3660, and Cisco 3700 series with Advanced Integration Modules (AIMs) or Cisco 3660 routers with Multiservice Interchange (MIX) Modules. It names a controller to provide clocking signals to the backplane, which then provides them to all the network modules that are participating in network clocking.

Cisco MC3810

This command applies to Voice over Frame Relay, Voice over ATM, and Voice over HDLC on the Cisco MC3810.

Examples**Cisco 2600 series and Cisco 3660**

This example selects the controller in slot 5, port 1, to provide the clock at priority 3:

```
Router(config)# network-clock-select 3 t1 5/1
```

Cisco MC3810

The following example sets the priority of four network clock sources. When the clock source with the highest priority (controller T1 0) fails, the Cisco MC3810 switches the clock source to the second highest priority (controller T1 1).

```
Router(config)# network-clock-select 1 T1 0
Router(config)# network-clock-select 2 T1 1
Router(config)# network-clock-select 3 serial 0
```

```
Router(config)# network-clock-select 4 System
```

Related Commands

Command	Description
network-clock-participate	(Cisco 2600 series and Cisco 3660) Configures a network module to participate in network clocking.
network-clock-switch	(Cisco MC3810) Configures the switch delay time to the next priority network clock source when the current network clock source fails.

voice-card

To enter voice-card configuration mode to configure a card with voice processing resources, enter the **voice-card** command in global configuration mode.

voice-card *slot*

Syntax Description

<i>slot</i>	Slot number for the card to be configured. <ul style="list-style-type: none"> • Cisco 2600 series—0 is the Advanced Integration Module (AIM) slot in the router chassis, and 1 is the network module slot in the router chassis. • Cisco 3600 series—1 to 6 identifies a network module slot in the router chassis. • Cisco 3660—7 is AIM slot 0 in the router chassis, and 8 is AIM slot 1. • Cisco MC3810 concentrators with one or two high-performance voice compression modules (HCMs) installed—0 applies to the entire chassis. <p>Note The CiscoMC3810 is not supported with the AIM-ATM, AIM-VOICE-30, and AIM-ATM-VOICE-30 on the Cisco 2600 Series, Cisco 3660, and Cisco 3700 Series feature.</p>
-------------	--

Defaults

No default values.

Command Modes

Global configuration

Command History

Release	Modification
12.0(5)XK	The command was introduced for the Cisco 2600 series and Cisco 3600 series.
12.0(7)T	This command was integrated into Cisco IOS Release 12.0(7)T.
12.0(7)XK	This command was first supported on the Cisco MC3810 series.
12.1(2)T	This command was integrated into Cisco IOS Release 12.1(2)T.
12.2(2)XB	Values for <i>slot</i> were updated to include AIMS.
12.2(8)T	This command was integrated into Cisco IOS Release 12.2(8)T.
12.2(15)T	This command was implemented on the Cisco 2691 and the Cisco 3700 series.

Usage Guidelines

Voice card configuration mode is used for commands that configure the use of digital signal processing (DSP) resources, such as codec complexity and digital signal processor (DSP). DSP resources can be found in digital T1/E1 packet voice trunk network modules on Cisco 2600 series and Cisco 3600 series

routers, and on high-performance compression modules on Cisco MC3810 multiservice access concentrators. DSP resources are also found on some advanced integration modules (AIM-VOICE-30 and AIM-ATM-VOICE-30) on Cisco 2600 series and Cisco 3660 or Cisco 3700 series.

Codec complexity is configured in voice-card configuration mode. On the Cisco 2600 series and Cisco 3600 series, the *slot* argument corresponds to the physical chassis slot of the network module with DSP resources to be configured. On the Cisco MC3810 series, the *slot* argument is always 0, and the changes that are made in voice-card mode apply to the entire Cisco MC3810. On the Cisco MC3810 series, the **voice-card** command is available only if the chassis is equipped with one or two HCMs.

DSP resource sharing is also configured in voice-card configuration mode. On Cisco 2600 series and Cisco 3660 routers under specific circumstances, configuration of the **dspfarm** command enters DSP resources on a network module or AIM into a DSP resource pool. Those DSP resources are then available to process voice traffic on a different network module or voice/WAN interface card (VWIC). See [dspfarm \(voice-card\)](#) for more information about DSP resource sharing.

Examples

The following example enters voice-card configuration mode to configure resources on the network module in slot 1 on a Cisco 2600 series or Cisco 3600 series router:

```
Router(config)# voice-card 1  
Router(config-voicecard)#
```

The following example enters voice-card configuration mode on a Cisco MC3810 concentrator:

```
Router(config)# voice-card 0  
Router(config-voicecard)#
```

Glossary

AAL—ATM adaptation layer. Service-dependent sublayer of the data link layer. The AAL accepts data from different applications and presents it to the ATM layer in the form of 48-byte ATM payload segments. AALs consist of two sublayers: the convergence sublayer (CS) and the segmentation and reassembly sublayer (SAR). AALs differ on the basis of the source-destination timing used, whether they use constant bit rate (CBR) or variable bit rate (VBR), and whether they are used for connection-oriented or connectionless mode data transfer. At present, the four types of AAL recommended by the ITU-T are AAL1, AAL2, AAL3/4, and AAL5.

AAL2—ATM adaptation layer 2. One of four AALs recommended by the ITU-T. AAL2 is used for connection-oriented services that support a variable bit rate, such as some isochronous video and voice traffic.

AAL5—ATM adaptation layer 5. One of four AALs recommended by the ITU-T. AAL5 is used for connection-oriented services that support a variable bit rate, such as some isochronous video and voice traffic.

AIM—Advanced Integration Module. Hardware with components that provide specialized processing.

ATM—Asynchronous Transfer Mode. International standard for cell relay in which multiple service types (such as voice, video, or data) are conveyed in fixed-length (53-byte) cells. Fixed-length cells allow cell processing to occur in hardware, thereby reducing transit delays. ATM is designed to take advantage of high-speed transmission media such as E3, SONET, and T3.

CAS—channel associated signaling. The transmission of signaling information within the voice channel. CAS signaling often is referred to as robbed-bit signaling because user bandwidth is being robbed by the network for other purposes.

DS0—digital service zero (0). Single timeslot on a DS1 (also known as T1) digital interface—that is, a 64-kbps, synchronous, full-duplex data channel, typically used for a single voice connection on a PBX. See also DS1 and PBX.

DSP—digital signal processor. A DSP segments the voice signal into frames and stores them in voice packets.

DSP resource pool—A collection of DSP resources available to a network module or VWIC on the router. These resources are found on another network module or on an AIM.

IMA—inverse multiplexing over ATM, a standard defined by the ATM Forum. IMA provides economical, high-bandwidth ATM WAN access by enabling multiple T1 or E1 ATM links to be combined and to appear as one physical link to higher layers.

MIX—multiservice interchange. Feature that allows TDM connections between MIX-enabled ports.

PBX—private branch exchange. Privately owned central switching office.

PDU—protocol data unit. Another name for packet.

PLL—phase-locked loop. An electronic circuit that synchronizes itself to an external reference signal. It locks itself onto the phase or onto the average frequency of the incoming signal, dynamically tracks it, and outputs a related but more useful version. Among the typical applications of a PLL in digital circuits are synchronizing a system to a single clock source and jitter filtering (removing phase noise).

PSTN—public switched telephone network. General term referring to the variety of telephone networks and services in place worldwide. Sometimes called POTS.

SAR—segmentation and reassembly. In ATM, the processes of dividing PDUs into 48-byte pieces of payload data at the source for transport, and then reassembling them into a stream at the destination.

VIC—voice interface card. Provides voice-specific ports, including foreign exchange station (FXS), foreign exchange office (FXO), ear and mouth (E&M), and basic rate interchange (BRI).

VWIC—A card that can operate as a VIC or as a WIC, providing physical connection to WAN or voice networks.

VoATM—Voice over ATM.

VoFR—Voice over Frame Relay.

VoIP—Voice over IP. The ability to carry normal telephony-style voice over an IP-based Internet with circuit-based telephone-like functionality, reliability, and voice quality. VoIP is a blanket term that generally refers to the Cisco standards-based (H.323, and so forth) approach to IP voice traffic.

WIC—WAN (wide-area network) interface card.

**Note**

Refer to the [Internetworking Terms and Acronyms](#) for terms not included in this glossary.
