



Start Here: MPLS AToM: Transport, Platform, and Release Specifics

The AToM documentation set describes the AToM features and explains how to implement them. This chapter includes the following sections:

- [Documentation Specifics, page 1](#)
- [Feature History, page 2](#)
- [Supported Software Releases and Platforms, page 2](#)
- [Restrictions, page 7](#)
- [Related Features and Technologies, page 9](#)
- [Related Documents, page 9](#)
- [Supported Standards, MIBs, and RFCs, page 10](#)
- [What To Do Next, page 11](#)

Documentation Specifics

This documentation set includes the following sections:

- *Start Here: MPLS AToM: Transport, Platform, and Release Specifics* (this document)
- *MPLS AToM: Overview*
- *MPLS AToM: Configuring*
- *MPLS AToM: Commands*



Note

This chapter details the features that are supported in each release and on each platform. Not all MPLS AToM features are supported in each Cisco IOS software release for each platform. Read the entire chapter before reading the other MPLS AToM chapters.

The other chapters provide overview, configuration, and command reference information for MPLS AToM features.

Feature History

Table 1 outlines the development of the MPLS AToM features.

Table 1 *MPLS AToM Feature History*

Cisco IOS Release	Revision
12.0(10)ST	MPLS AToM: ATM AAL5 over MPLS was introduced on the Cisco 12000 series routers.
12.1(8a)E	MPLS AToM: Ethernet over MPLS was introduced on the Cisco 7600 series Internet router.
12.0(21)ST	Ethernet over MPLS was introduced on the Cisco 12000 series routers. ATM AAL5 over MPLS was updated.
12.0(22)S	Ethernet over MPLS was integrated into this release. Support for the Cisco 10720 router was added. AAL5 over MPLS was integrated into this release.
12.0(23)S	The following MPLS features were introduced: <ul style="list-style-type: none"> • ATM Cell Relay over MPLS • Frame Relay over MPLS • HDLC over MPLS • PPP over MPLS The following features were updated: <ul style="list-style-type: none"> • Ethernet over MPLS • AAL5 over MPLS
12.2(14)S	This feature was integrated into Cisco IOS Release 12.2(14)S.
12.2(15)T	This feature was integrated into Cisco IOS Release 12.2(15)T.

Supported Software Releases and Platforms

Cisco IOS Release 12.1(15)T includes the following AToM transports, which are supported on the Cisco 7200 and 7500 series routers:

- ATM AAL5 over MPLS
- ATM Cell Relay over MPLS
- Ethernet over MPLS
- Frame Relay over MPLS
- HDLC over MPLS
- PPP over MPLS

Table 2 and Table 3 provide all the releases and platforms on which ATM AAL5 over MPLS and Ethernet over MPLS are supported.

Table 2 ATM AAL5 over MPLS Supported Releases and Platforms

Supported Releases	Supported Platforms
12.0(10)ST	Cisco 12000 series routers
12.0(21)ST	Cisco 12000 series routers and additional line cards
12.0(23)S	Cisco 7200, 7500, and 12000 series routers Note Earlier releases of AAL5 over MPLS do not work with this release. You must upgrade all routers to the latest release of ATM AAL5 over MPLS.
12.2(14)S	Cisco 7200 and 7500 series routers
12.2(15)T	Cisco 7200 and 7500 series routers

Table 3 Ethernet over MPLS Supported Releases and Platforms

Supported Releases	Supported Platforms
12.1(8a)E	Cisco 7600 series Internet routers
12.0(21)ST	Cisco 12000 series routers
12.0(22)S	Cisco 12000 series routers and 10720 router
12.0(23)S	Cisco 7200, 7500, 10720, and 12000 series routers
12.2(14)S	Cisco 7200 and 7500 series routers
12.2(15)T	Cisco 7200 and 7500 series routers

Supported Chassis Types and Processors

The Cisco 7200 and 7500 series routers can use the following chassis types and processors:

- Cisco 7200 series routers
 - Chassis: All 7200-VXR chassis types
 - Processors: NPE-225, NPE-300, NPE-400, NPE-G, NSE-1
- Cisco 7500 series routers
 - Chassis: All 7500 chassis types
 - Processors: RSP4, RSP4+, RSP8
 - VIPs: VIP2-50, VIP4-50, VIP4-80



Note The chassis, processors, and VIPs listed have been tested and are supported for use with MPLS AToM. All other chassis, processors, and VIPs have not been tested and therefore are not supported. In future releases, you will not be able to configure AToM on unsupported hardware.

Supported Port Adapters

The following port adapters are supported for the Cisco 7200 and 7500 series routers for each transport type in Cisco IOS Release 12.0(23)S.

ATM AAL5 over MPLS

- PA-A3-OC3
- PA-A3-T3
- PA-A3-E3
- PA-A3-OC12
- PA-A3-8T1IMA
- PA-A3-8E1IMA

Notes:

- Hardware revision 1.0 of the following port adapters is not supported:
 - PA-A3-OC3
 - PA-A3-E3
 - PA-A3-T3
- ATM Cell Relay over MPLS is not supported on the following port adapters:
 - PA-A1-OC3
 - PA-A2-OC3

ATM Cell Relay over MPLS

**Note**

In this release, ATM Cell Relay over MPLS supports the transport of single cells. The configuration of the AToM circuit requires that you use PVCs.

- PA-A3-OC3
- PA-A3-E3
- PA-A3-T3

Notes:

- Hardware revision 1.0 of the following port adapters is not supported:
 - PA-A3-OC3
 - PA-A3-E3
 - PA-A3-T3
- ATM Cell Relay over MPLS is not supported on the following port adapters:
 - PA-A1-OC3
 - PA-A2-OC3

Ethernet over MPLS

**Note**

In this release, Ethernet over MPLS supports the transport of Ethernet VLAN cells.

7200 and 7500

- PA-2FE
- PA-FE

7200 only

- PA-GE
- C7200-I/O-2FE
- C7200-I/O-GE+E (Only the Gigabit Ethernet port of this port adapter is supported.)

7500 only

- GEIP
- GEIP+

Frame Relay over MPLS

- PA-MC-8T1
- PA-MC-8E1
- PA-MC-2T3+
- PA-MC-T3
- PA-T3
- PA-2T3
- PA-T3+
- PA-4T+
- PA-2T3+
- PA-8T-V35
- PA-E3
- PA-2E3

Restrictions

- PA-MC-E3
- PA-MC-2E1
- PA-MC-4T1
- PA-MC-STM1
- PA-MC-2T1
- PA-MC-8TE1+
- PA-POS-OC3
- PA-HSSI
- PA-2HSSI
- PA-4E1G120
- PA-8T-232
- PA-8T-X21

HDLC over MPLS

- PA-4T
- PA-4T+
- PA-8T
- PA-H
- PA-2H
- PA-POS-OC3-SMI
- PA-POS-OC3-SML
- PA-POS-OC3-MM



Note Only serial, POS, and HSSI interfaces are supported. Channelized interfaces are not supported.

PPP over MPLS

- PA-4T
- PA-4T+
- PA-8T
- PA-H
- PA-2H
- PA-POS-OC3-SMI
- PA-POS-OC3-SML
- PA-POS-OC3-MM



Note Only serial, POS, and HSSI interfaces are supported. Channelized interfaces are not supported.

Determining Platform Support Through Cisco Feature Navigator

Cisco IOS software is packaged in feature sets that are supported on specific platforms. To get updated information regarding platform support for this feature, access Cisco Feature Navigator. Cisco Feature Navigator dynamically updates the list of supported platforms as new platform support is added for the feature.

Cisco Feature Navigator is a web-based tool that enables you to quickly determine which Cisco IOS software images support a specific set of features and which features are supported in a specific Cisco IOS image. You can search by feature or release. Under the release section, you can compare releases side by side to display both the features unique to each software release and the features in common.

To access Cisco Feature Navigator, you must have an account on Cisco.com. If you have forgotten or lost your account information, send a blank e-mail to cco-locksmith@cisco.com. An automatic check will verify that your e-mail address is registered with Cisco.com. If the check is successful, account details with a new random password will be e-mailed to you. Qualified users can establish an account on Cisco.com by following the directions found at this URL:

<http://www.cisco.com/register>

Cisco Feature Navigator is updated regularly when major Cisco IOS software releases and technology releases occur. For the most current information, go to the Cisco Feature Navigator home page at the following URL:

<http://www.cisco.com/go/fn>

Availability of Cisco IOS Software Images

Platform support for particular Cisco IOS software releases is dependent on the availability of the software images for those platforms. Software images for some platforms may be deferred, delayed, or changed without prior notice. For updated information about platform support and availability of software images for each Cisco IOS software release, refer to the online release notes or, if supported, Cisco Feature Navigator.

Restrictions

The following general restrictions pertain to all transport types under AToM:

- **Out-of-order packets:** AToM does not support detecting of out-of-order packets.
- **Quality of Service:** AToM QOS is not supported in this release.
- **Fast Reroute:** Fast Reroute (FRR) can co-exist with AToM in a network. However, FRR does not provide link protection for AToM virtual circuits (VCs).
- **Address format:** All loopback addresses on PE routers must be configured with 32-bit masks to ensure proper operation of MPLS forwarding between PE routers.
- **Maximum transmission unit:** Because MPLS AToM does not allow packets to be fragmented and reassembled, ensure that the maximum transmission unit (MTU) of all intermediate links between endpoints is sufficient to carry the largest Layer 2 VLAN packet received. See the Troubleshooting section of the *MPLS AToM: Configuring* chapter for more information.
- **VC ID:** When you use the `mpls l2transport route` command, make sure that the two values you enter (the IP address of the remote PE router and VC ID) make a unique pairing.

The following sections list restrictions by transport type and platform (if applicable).

ATM AAL5 over MPLS Restrictions

The following restrictions pertain to the ATM AAL5 over MPLS feature:

- **SDU mode:** AAL5 over MPLS is supported only in SDU mode.
- **PVC configuration:** You can configure ATM AAL5 over MPLS on permanent virtual circuits (PVCs) only. You cannot configure ATM AAL5 over MPLS on main interfaces.

ATM Cell Relay over MPLS Restrictions

The following restrictions pertain to the ATM Cell Relay over MPLS feature:

- **PVC configuration:** You can configure ATM Cell Relay over MPLS on PVCs only. You cannot configure ATM Cell Relay over MPLS on main interfaces.
- **Single cell relay:** In this release, each MPLS packet contains one ATM cell. In other words, each ATM cell is transported as a single packet.
- **Control word:** The use of the control word is not supported.
- **TE tunnels:** If you have traffic engineering (TE) tunnels running between the PE routers, you must enable LDP on the tunnel interfaces.
- **Port Adapters:** Cell Relay over MPLS is not supported on hardware revision 1.0 PA-A3-OC3, PA-A3-E3, and PA-A3-T3 Port Adapters.
- **VCC mode:** ATM Cell Relay over MPLS supports only virtual channel connection (VCC) mode.

Ethernet over MPLS Restrictions

The following restrictions pertain to the Ethernet over MPLS feature:

- **Packet format:** Ethernet over MPLS supports VLAN packets that conform to the IEEE 802.1Q standard. The 802.1Q specification establishes a standard method for inserting VLAN membership information into Ethernet frames. Inter-Switch Link (ISL) protocol is not supported between the PE and customer edge (CE) routers.
- **Configuring on subinterfaces:** You must enable Ethernet over MPLS by specifying the `mpls l2transport route` command on an 802.1Q subinterface.

Cisco 7200/7500 series Routers Restrictions with Ethernet over MPLS

The following restrictions apply to the Cisco 7200 and/or 7500 series routers:

- **VLAN ID rewrite:** The Cisco 7200 and 7500 series routers support the VLAN ID rewrite feature, which enables you to use VLAN interfaces with different VLAN IDs at both ends of the tunnel.

Frame Relay over MPLS Restrictions

The following restrictions pertain to the Frame Relay over MPLS feature:

- **Distributed CEF (dCEF):** On the Cisco 7500 series routers, distributed processing for Frame Relay over MPLS is not supported. Therefore, whether you enable CEF or dCEF, the route switch processor (RSP) switches all frame relay packets. This restriction does not affect other features that are processed in distributed mode.

HDLC over MPLS Restrictions

The following restrictions pertain to the HDLC over MPLS feature:

- **Asynchronous interfaces:** Asynchronous interfaces are not supported.
- **Interface configuration:** You must configure HDLC over MPLS on router interfaces only. You cannot configure HDLC over MPLS on subinterfaces.
- **Distributed CEF (dCEF):** On the Cisco 7500 series routers, distributed processing for HDLC over MPLS is not supported. This restriction does not affect other features that are processed in distributed mode.

PPP over MPLS Restrictions

The following restrictions pertain to the PPP over MPLS feature:

- **Zero hops between PE routers:** Zero hops on one router is not supported. However, you can have back-to-back PE routers.
- **Asynchronous interfaces:** Asynchronous interfaces are not supported. The connections between the CE and PE routers on both ends of the backbone must have similar link layer characteristics. The connections between the CE and PE routers must both be synchronous.
- **Multilink PPP:** Multilink PPP (MLP) is not supported.
- **Distributed CEF (dCEF):** On the Cisco 7500 series routers, distributed processing for PPP over MPLS is not supported. This restriction does not affect other features that are processed in distributed mode.

Related Features and Technologies

Layer 2 Tunnel Protocol Version 3 (L2TPv3) provides the ability to tunnel any Layer 2 payload over an IP core network using Layer 2 virtual private networks (L2VPNs). For more information on this feature, see the following documents:

- *Layer 2 Tunnel Protocol Feature Summary*
- *Layer 2 Tunneling Protocol: A Feature in Cisco IOS Software*
- *Layer 2 Tunnel Protocol Version 3 (L2TPv3) Feature Module*
- *Unified VPN Suite*

Related Documents

See the following documents for more information about AToM:

- [Data Sheet: Any Transport over MPLS](#)
- [White Paper: Cisco Any Transport over MPLS](#)
- [Overview: Cisco Any Transport over MPLS](#)

Supported Standards, MIBs, and RFCs

Standards

- *Transport of Layer 2 Frames Over MPLS*
draft-martini-l2circuit-trans-mpls-08.txt
- *Encapsulation Methods for Transport of Layer 2 Frames Over MPLS*
draft-martini-l2circuit-encap-mpls-04.txt

You can find the drafts of these documents at <http://search.ietf.org>.

MIBs

Transport Type	Supported MIBs
ATM AAL5 over MPLS and ATM Cell Relay over MPLS	MPLS LDP MIB (MPLS-LDP-MIB.my) ATM MIB (ATM-MIB.my) CISCO AAL5 MIB (CISCO-AAL5-MIB.my) Cisco Enterprise ATM Extension MIB (CISCO-ATM-EXT-MIB.my) Supplemental ATM Management Objects (CISCO-IETF-ATM2-PVCTRAP-MIB.my) Interfaces MIB (IF-MIB.my)
Ethernet over MPLS	CISCO-ETHERLIKE-CAPABILITIES.my Ethernet MIB (ETHERLIKE-MIB.my) Interfaces MIB (IF-MIB.my) MPLS LDP MIB (MPLS-LDP-MIB.my)
Frame Relay over MPLS	Cisco Frame Relay MIB (CISCO-FRAME-RELAY-MIB.my) Interfaces MIB (IF-MIB.my) MPLS LDP MIB (MPLS-LDP-MIB.my)
HDLC and PPP over MPLS	MPLS LDP MIB (MPLS-LDP-MIB.my) Interface MIB (IF-MIB.my)

To locate and download MIBs for selected platforms, Cisco IOS releases, and feature sets, use Cisco MIB Locator found at the following URL:

<http://tools.cisco.com/ITDIT/MIBS/servlet/index>

If Cisco MIB Locator does not support the MIB information that you need, you can also obtain a list of supported MIBs and download MIBs from the Cisco MIBs page at the following URL:

<http://www.cisco.com/public/sw-center/netmgmt/cmtk/mibs.shtml>

To access Cisco MIB Locator, you must have an account on Cisco.com. If you have forgotten or lost your account information, send a blank e-mail to cco-locksmith@cisco.com. An automatic check will verify that your e-mail address is registered with Cisco.com. If the check is successful, account details with a new random password will be e-mailed to you. Qualified users can establish an account on Cisco.com by following the directions found at this URL:

<http://www.cisco.com/register>

RFCs

- RFC 3032, *MPLS Label Stack Encoding*
- RFC 3036, *LDP Specification*

What To Do Next

See the following MPLS AToM documentation for more information:

- *MPLS AToM: Overview*
- *MPLS AToM: Configuring*
- *MPLS AToM: Commands*



MPLS AToM — Overview

This document provides an introduction to MPLS AToM and includes the following sections:

- [Documentation Specifics, page 14](#)
- [Feature Overview, page 14](#)
- [Benefits, page 24](#)
- [What To Do Next, page 24](#)

Documentation Specifics

This documentation set includes the following sections:

- *Start Here: MPLS AToM: Transport, Platform, and Release Specifics*
- *MPLS AToM: Overview* (this document)
- *MPLS AToM: Configuring*
- *MPLS AToM: Commands*



Note

Start Here: MPLS AToM: Transport, Platform, and Release Specifics details the features that are supported in each release and on each platform. Not all MPLS AToM features are supported in each Cisco IOS software release for each platform. Read the entire chapter before reading the other MPLS AToM chapters.

The other chapters provide overview, configuration, and command reference information for MPLS AToM features.

Feature Overview

Any Transport over MPLS (AToM) is a solution for transporting Layer 2 packets over an MPLS backbone. AToM enables service providers to supply connectivity between customer sites with existing data link layer (Layer 2) networks by using a single, integrated, packet-based network infrastructure — a Cisco MPLS network. Instead of separate networks with network management environments, service providers can deliver Layer 2 connections over an MPLS backbone.

With Cisco AToM technology, provisioning and connecting is straightforward. A customer using Ethernet in a building or campus in one location can connect through a service provider offering Ethernet over MPLS to the customer's Ethernet networks in remote locations.

AToM provides a common framework to encapsulate and transport supported Layer 2 traffic types over an MPLS network core. Service providers can use a single MPLS network infrastructure to offer customers connectivity for supported Layer 2 traffic, as well as customers' IP traffic in Layer 3 VPNs.

AToM supports the following transport types:

- ATM AAL5 over MPLS
- ATM Cell Relay over MPLS
- Ethernet VLAN over MPLS
- Frame Relay over MPLS
- PPP over MPLS
- HDLC over MPLS

ATM AAL5 over MPLS

How ATM AAL5 SDUs Move Between PE Routers

ATM AAL5 over MPLS encapsulates ATM AAL5 service data units (SDUs) in MPLS packets and forwards them across the MPLS network. Each AAL5 SDU is transported as a single packet. The following steps outline the process of encapsulating the SDU.

Ingress PE router

1. An ingress provider edge (PE) router receives an ATM AAL5 SDU and removes the header.
2. The PE router copies the control word elements from the header to the corresponding fields in the control word of the SDU. The control word contains:
 - Explicit forward congestion indication (EFCI) bit—Used by ATM switches to indicate congestion experienced by forwarded data cells.
 - Cell loss priority (CLP) bit—Indicates whether a cell should be dropped if it encounters extreme congestion as it moves through the ATM network.
3. The PE router adds a virtual circuit (VC) label and a label switched path (LSP) tunnel label to the packet for normal MPLS routing through the MPLS backbone. The core routers use the LSP tunnel label to move the packet through the MPLS backbone. A core router does not distinguish ATM AAL5 traffic from other types of traffic. The packet is handled just like other packets in the MPLS backbone.

Egress PE router

1. At the other edge of the MPLS backbone, the egress PE router receives the packet and copies the control word elements from the control word to the header.
2. The PE router removes the VC label and LSP tunnel label if one is present. If no LSP tunnel label is present, it is because the penultimate router removed that label.
3. The PE router adds an AAL5 header and sends the packet out the appropriate customer-facing interface.

Figure 1 illustrates this process.

Figure 1 ATM AAL5 Packets as They Traverse the MPLS Backbone

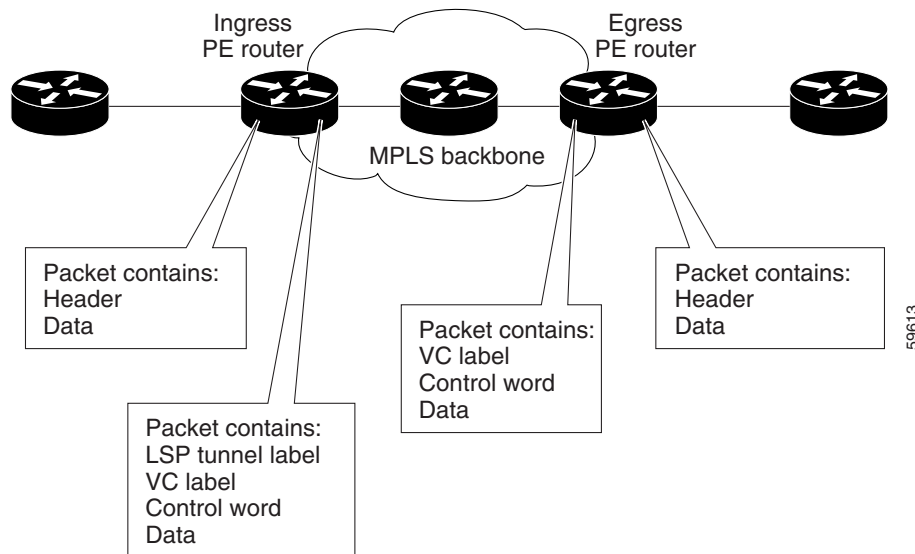

AAL5 Packets Containing OAM Cells

The Cisco 7200 and 7500 series routers support the transport of F5 end-to-end operational, administrative, and maintenance (OAM) cells. Only Mode 0 is supported. F5 OAM cells are transported over the MPLS backbone with the payload. The OAM cell fits into the payload of a single AAL5 packet.

Notes:

- PVC switching is not supported in OAM encapsulation.
- Both PE routers must be configured with the same VPI/VCI value.
- OAM transparency is not supported on the Cisco 12000 series routers.

OAM Cell Emulation

Supported Platforms:

This functionality is supported on the following platforms:

- Cisco 7200 series routers
- Cisco 7500 series routers

If a PE router does not support the transport of OAM cells across an LSP, you can use OAM cell emulation to locally terminate or loopback the OAM cells. You configure OAM cell emulation on both PE routers, which emulates a VC by forming two unidirectional LSPs. You use the **oam-ac emulation-enable** command on both PE routers to enable OAM cell emulation.

After OAM cell emulation is enabled on a router, you can configure and manage the ATM VC in the same manner as you would a terminated VC. A VC that has been configured with OAM cell emulation can send loopback cells at configured intervals toward the local CE router. The endpoint can be either of the following:

- End-to-end loopback, which sends OAM cells to the local CE router.

- Segment loopback, which responds to OAM cells to a device along the path between the PE and CE routers.

The OAM cells include the following:

- Alarm indication signal (AIS)
- Remote defect indication (RDI)

These cells identify and report defects along a VC. When a physical link or interface failure occurs, intermediate nodes insert OAM AIS cells into all the downstream devices affected by the failure. When a router receives an AIS cell, it marks the ATM VC down and sends an RDI cell to let the remote end know about the failure.

See the [Configure OAM Cell Emulation for ATM AAL5 over MPLS](#) section for information on configuring OAM cell emulation.

ATM Cell Relay over MPLS

ATM Cell Relay over MPLS transports single ATM cells over the MPLS backbone. The AToM circuit is configuring on permanent virtual circuits. In this release, only PVC mode, single cell relay is supported.

How ATM Cells Move Between PE Routers

ATM Cell Relay over MPLS encapsulates ATM cells in MPLS packets and forwards them across the MPLS network. Each MPLS packet contains one ATM cell. In other words, each ATM cell is transported as a single packet. The following steps outline the process of encapsulating the ATM cell.

Ingress PE Router

1. The ingress PE router receives an ATM cell and removes the header. The following items are not removed from the ATM cell:
 - The control word. The control word contains:
 - Explicit forward congestion indication (EFCI) bit — Used by ATM switches to indicate congestion experienced by forwarded data cells.
 - Cell loss priority (CLP) bit** — indicates whether a cell should be dropped if it encounters extreme congestion as it moves through the ATM network.
 - The virtual path identifier (VPI) and virtual channel identifier (VCI). The VPI and VCI identify the next destination of a cell as it passes through a series of ATM switches on its way to its destination. ATM switches use the VPI/VCI fields to identify the next virtual channel link (VCL) that a cell needs to transit on its way to its final destination.
2. The PE router adds a VC label and an LSP tunnel label to the packet for normal MPLS routing through the MPLS backbone. The P routers use the LSP tunnel label to move the packet through the MPLS backbone. A core router does not distinguish ATM Cell Relay traffic from other types of traffic. The packet is handled just like other packets in the MPLS backbone.

Egress PE Router

1. At the other edge of the MPLS backbone, the egress PE router receives the packet and removes the LSP tunnel label if one is present. If no LSP tunnel label is present, it is because the penultimate router removed that label. The PE router also removes the control word and VC label from the packet.

- The PE router adds an ATM header and sends the packet out the appropriate customer facing interface.

Figure 2 illustrates this process.

Figure 2 ATM Cell Packets as They Traverse the MPLS Backbone

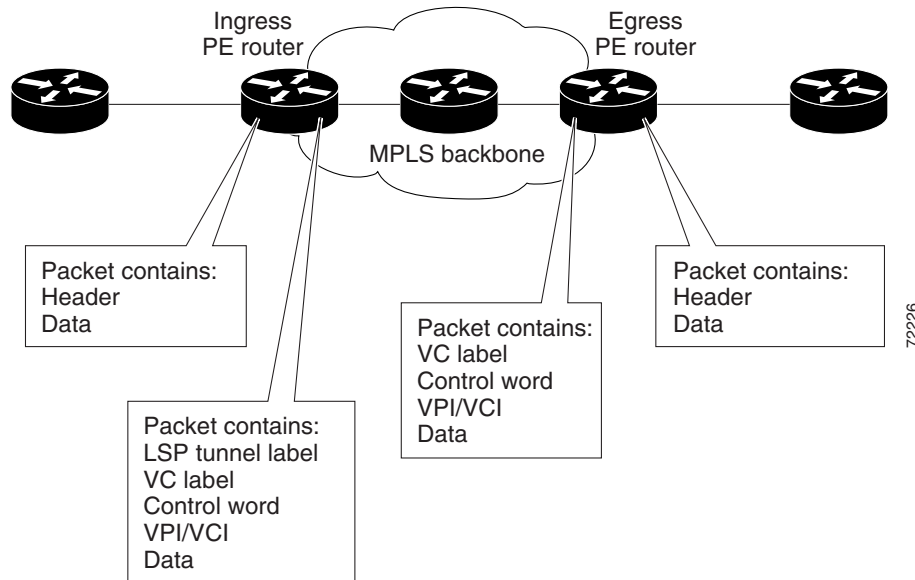

ATM Packets Containing OAM Cells

If F5 end-to-end operational, administrative, and maintenance (OAM) cells are included in a packet, they are transported over the MPLS backbone with the payload. The OAM cell fits into the payload of a single packet. The Cisco 7200 and 7500 series routers support the transport of F5 end-to-end OAM cells. Only

Ethernet over MPLS

How Ethernet PDUs Move Between PE Routers

Ethernet over MPLS works by encapsulating Ethernet PDUs in MPLS packets and forwarding them across the MPLS network. Each PDU is transported as a single packet. The following steps outline the process of encapsulating the PDU.

Ingress PE Router:

- The ingress PE router receives a PDU and removes the preamble, start of frame delimiter (SFD), and the frame check sequence (FCS). The rest of the header remains the same.
- The PE router copies the control word from the header, even though it is not used. The PE router adds a VC label and LSP tunnel label for normal MPLS routing through the MPLS backbone. The core routers use the LSP tunnel label to move the packet through the MPLS backbone. A core router does not distinguish Ethernet traffic from other types of traffic. The packet is handled just like other packets in the MPLS backbone.

Egress PE Router

1. At the other edge of the MPLS backbone, the egress PE router receives the packet and removes the LSP tunnel label if one is present. If no LSP tunnel label is present, it is because the penultimate router removed that label. The PE router also removes the control word and VC label from the packet.
2. The PE router updates the header if necessary and sends the packet out the appropriate customer facing interface.

Figure 3 illustrates this process.

Figure 3 *Ethernet Packets as They Traverse the MPLS Backbone*

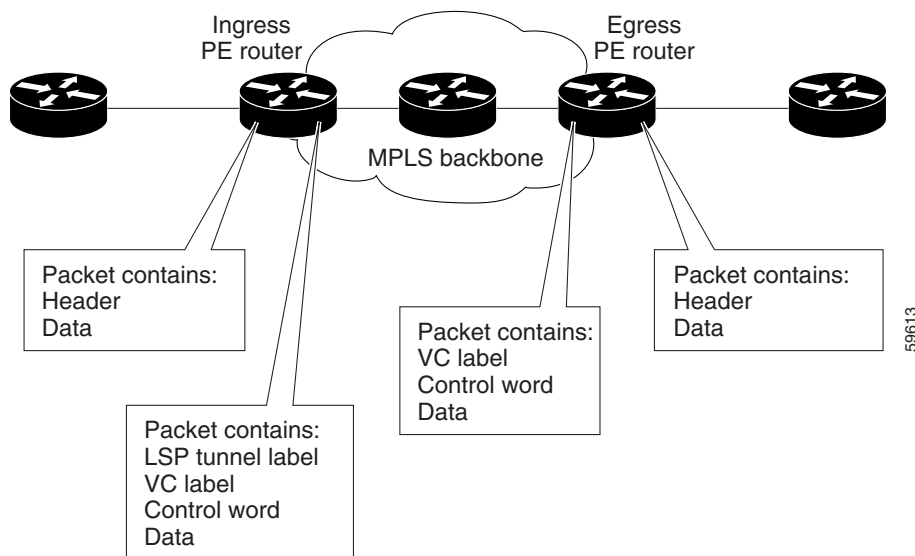

Frame Relay over MPLS

How Frame Relay PDUs Move Between PE Routers

Frame Relay over MPLS encapsulates Frame Relay protocol data units (PDUs) in MPLS packets and forwards them across the MPLS network. The process of transporting the PDU differs, depending on whether you set up DLCI-to-DLCI connections or port-to-port connections. The following sections explain both processes.

How Frame Relay Packets Move Between PE Routers with DLCI-to-DLCI Connections

The following steps outline the process of encapsulating the PDU in a Frame Relay configuration with DLCI-to-DLCI connections.

Ingress PE router

1. An ingress PE router receives a Frame Relay PDU and removes the Frame Relay header and the frame check sequence (FCS).
2. The PE router copies the control word elements from the Frame Relay header to the corresponding fields in the control word of the Frame Relay PDU. The control word elements include:

- Backward explicit congestion notification (BECN)
 - Forward explicit congestion notification (FECN)
 - Discard eligibility (DE)
 - Command/response
3. The PE router adds a VC label and an LSP tunnel label to the packet for normal MPLS routing through the MPLS backbone. The core routers use the LSP tunnel label to move the packet through the MPLS backbone. A core router does not distinguish Frame Relay traffic from other types of traffic. The packet is handled just like other packets in the MPLS backbone.

Egress PE router

1. At the other edge of the MPLS backbone, the egress PE router receives the packet and copies the control word elements from the control word to the Frame Relay header.
2. The egress PE router removes the VC label and LSP tunnel label if one is present. If no LSP tunnel label is present, it is because the penultimate router removed that label.
3. The PE router adds the Frame Relay header and sends the packet out the appropriate customer-facing interface.

Figure 4 illustrates this process.

Figure 4 Frame Relay Packets as They Traverse the MPLS Backbone

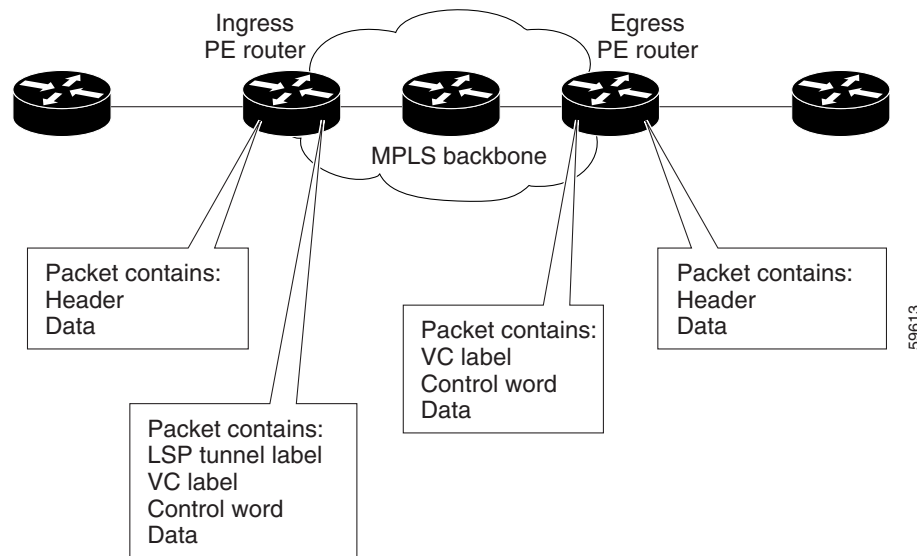

How Frame Relay Packets Move Between PE Routers with Port-to-Port Connections

When you set up a port-to-port connection between PE routers, you use HDLC mode to transport the Frame Relay encapsulated packets. In HDLC mode, the whole HDLC packet is transported. Only the HDLC flags and FCS bits are removed. The contents of the packet are not used or changed, including the FECN, BECN, and DE bits. For more information about the HDLC packets, see the “[How HDLC Packets Move Between PE Routers](#)” section on page 22.

Local Management Interface and Frame Relay over MPLS

Local Management Interface (LMI) is a protocol that communicates status information about permanent virtual circuits (PVCs). When a PVC is added, deleted, or changed, the LMI notifies the endpoint of the status change. LMI also provides a polling mechanism that verifies that a link is up.

How LMI Works

To determine the PVC status, LMI checks that a PVC is available from the reporting device to the Frame Relay end-user device. If PVC is available, LMI reports that the status is “Active.” A status of Active means that all interfaces, line protocols and core segments are operational between the reporting device and the Frame Relay end-user device. If any of those components is not available, the LMI reports a status of “Inactive.”



Note

Only the data circuit-terminating equipment (DCE) and network-to-network interface (NNI) interface types can report LMI status.

Figure 5 is a sample topology that helps illustrate how LMI works.

Figure 5 Sample Topology

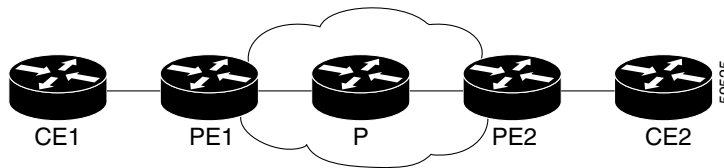

In Figure 5, note the following:

- CE1 and PE1 and PE2 and CE2 are Frame Relay LMI peers.
- CE1 and CE2 can be Frame Relay switches or end-user devices.
- Each Frame Relay PVC is composed of multiple segments.
- The DLCI value is local to each segment and is changed as traffic is switched from segment to segment. Two Frame Relay PVC segments exist in Figure 5; one is between PE1 and CE1 and the other is between PE2 and CE2.

How the LMI protocol behaves depends on whether you have DLCI-to-DLCI or port-to-port connections.

DLCI-to-DLCI Connections

If you have DLCI-to-DLCI connections, LMI runs locally on the Frame Relay ports between the PE and CE devices.

- CE1 sends an active status to PE1 if the PVC for CE1 is available. If CE1 is a switch, LMI checks that the PVC is available from CE1 to the user device attached to CE1.
- PE1 sends an active status to CE1 if the following conditions are met:
 - A PVC for PE1 is available.
 - PE1 has received an MPLS label from the remote PE router.
 - An MPLS tunnel label exists between PE1 and the remote PE.

- CE2 reports an Active status to PE2. If CE2 is a switch, LMI checks that the PVC is available from PE1 to the end user device attached to CE2.

For data terminal equipment (DTE)/DCE configurations, the following LMI behavior exists:

The Frame Relay device accessing the network (DTE) does the polling. The network device (DCE) responds to the LMI polls. Therefore, if a problem exists on the DTE side, the DCE is not aware of the problem, because it does not poll.

Port-to-Port Connections

If you have port-to-port connections, the PE routers do not participate in the LMI status-checking procedures. LMI operates between the customer edge (CE) routers only. The CE routers must be configured as DCE-DTE or NNI-NNI.

HDLC over MPLS

How HDLC Packets Move Between PE Routers

HDLC over MPLS encapsulates HDLC protocol data units (PDUs) in MPLS packets and forwards them across the MPLS network. The PE routers do not participate in any protocol negotiation or authentication. The following steps outline the process of encapsulating the PDU.

Ingress PE Router

1. An ingress PE router receives an HDLC PDU and removes the flags and the frame check sequence (FCS).
2. The PE router copies the control field to the PDU, even though the control field is not used. The PE router adds a VC label and LSP tunnel label for normal MPLS routing through the MPLS backbone. The core routers use the LSP tunnel label to move the packet through the MPLS backbone. A core router does not distinguish HDLC traffic from other types of traffic. The packet is handled just like other packets in the MPLS backbone.

Egress PE Router

1. At the other edge of the MPLS backbone, the PE router receives the packet and removes the VC label and the LSP tunnel label if one is present. If no LSP tunnel label is present, it is because the penultimate router removed that label.
2. The PE router adds the flags and FCS and sends the packet out the appropriate customer facing interface.

Figure 6 illustrates this process.

Figure 6 HDLC Packets as They Traverse the MPLS Backbone

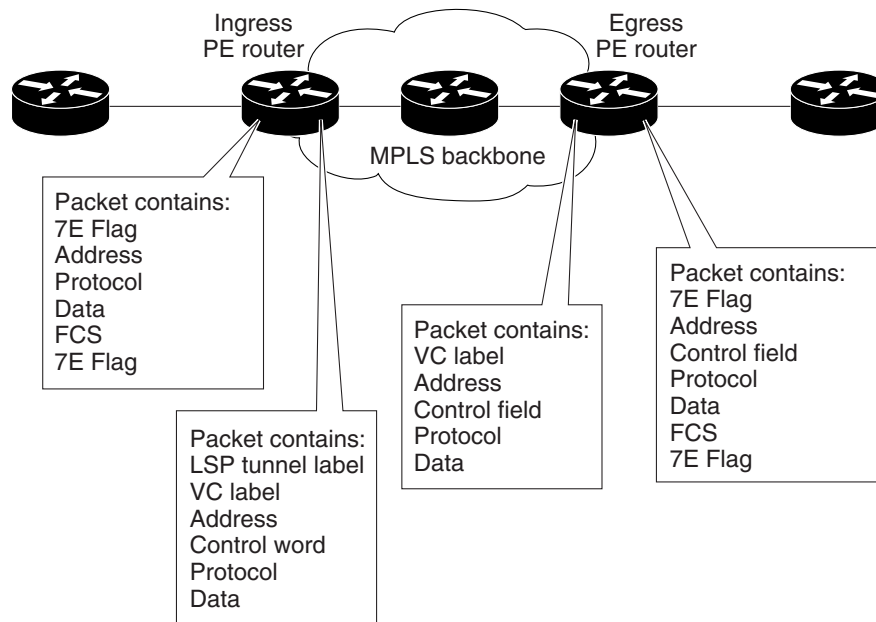

PPP over MPLS

How PPP Packets Move Between PE Routers

PPP over MPLS encapsulates PPP PDUs in MPLS packets and forwards them across the MPLS network. The PE routers do not participate in any protocol negotiation or authentication. The following steps outline the process of encapsulating the PDU.

Ingress PE Router

1. An ingress PE router receives a PPP PDU and removes the flags, address, control field, and the frame check sequence (FCS).
2. The PE router adds a VC label and LSP tunnel label to the packet for normal MPLS routing through the MPLS backbone. The core routers use the LSP tunnel label to move the packet through the MPLS backbone. A core router does not distinguish PPP traffic from other types of traffic. The packet is handled just like other packets in the MPLS backbone.

Egress PE Router

1. At the other edge of the MPLS backbone, the egress PE router receives the packet and removes the VC label and LSP tunnel label if one is present. If no LSP tunnel label is present, it is because the penultimate router removed that label.
2. The PE router adds the flags, address, control field, and FCS and sends the packet out the appropriate customer facing interface.

Figure 7 illustrates this process.

Figure 7 PPP Packets as They Traverse the MPLS Backbone

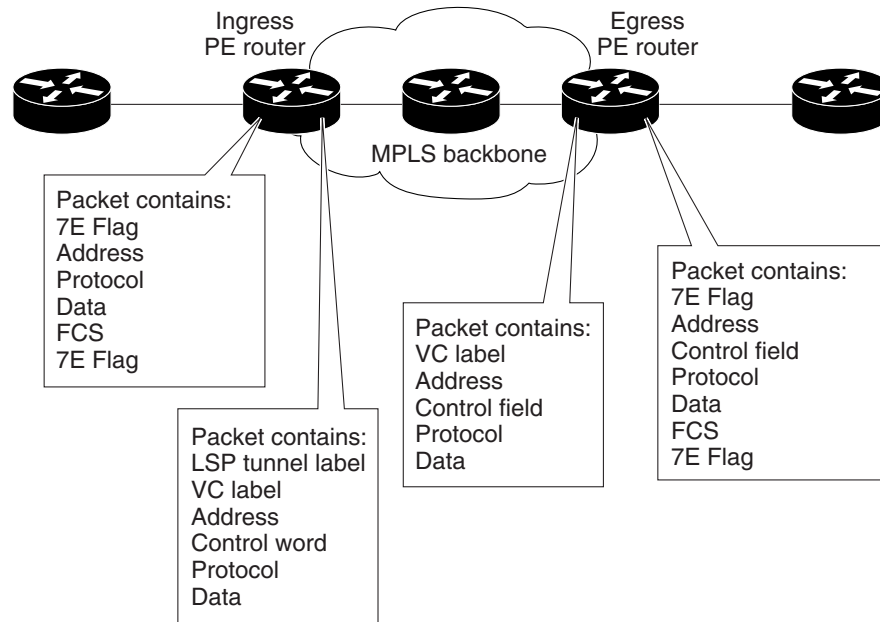

Benefits

The following list explains some of the benefits of enabling Layer 2 packets to be sent in the MPLS network:

- The AToM product set accommodates many types of Layer 2 packets, including Ethernet and Frame Relay, across multiple Cisco router platforms, such as the Cisco 7200 and 7500 series routers. This enables the service provider to transport all types of traffic over the backbone and accommodate all types of customers.
- AToM adheres to the standards developed for transporting Layer 2 packets over MPLS. (See the “Supported Standards, MIBs, and RFCs” section for the specific standards that AToM follows.) This benefits the service provider who wants to incorporate industry-standard methodologies in the network. Other Layer 2 solutions are proprietary, which can limit the service provider’s ability to expand the network and can force the service provider to use only one vendor’s equipment.
- Upgrading to AToM is transparent to the customer. Because the service provider network is separate from the customer network, the service provider can upgrade to AToM without disruption of service to the customer. The customers assume that they are using a traditional Layer 2 backbone.

What To Do Next

See the following MPLS AToM documentation for more information:

- *Start Here: MPLS AToM: Transport, Platform, and Release Specifics*
- *MPLS AToM: Configuring*
- *MPLS AToM: Commands*



MPLS AToM — Configuring

This document provides configuration tasks for the MPLS AToM and includes the following sections:

- [Documentation Specifics, page 27](#)
- [Prerequisites to Configuring, page 27](#)
- [Configuration Tasks, page 28](#)
- [Verification Tasks, page 33](#)
- [Enabling OAM Cell Emulation for ATM AAL5 over MPLS, page 37](#)
- [Troubleshooting Tasks, page 38](#)
- [Configuration Examples, page 41](#)
- [What To Do Next, page 45](#)

Documentation Specifics

This documentation set includes the following sections:

- *Start Here: MPLS AToM: Transport, Platform, and Release Specifics*
- *MPLS AToM: Overview*
- *MPLS AToM: Configuring* (this document)
- *MPLS AToM: Commands*



Note

Start Here: MPLS AToM: Transport, Platform, and Release Specifics details the features that are supported in each release and on each platform. Not all MPLS AToM features are supported in each Cisco IOS software release for each platform. Read the entire chapter before reading the other chapters.

The other chapters provide overview, configuration, and command reference information for MPLS AToM features.

Prerequisites to Configuring

Before configuring AToM, configure the following:

- Provide label switched paths (LSPs) between provider edge (PE) routers by enabling dynamic MPLS labeling (through the **mpls ip** command) on all paths between the imposition and disposition PE routers.
- Enable and configure Cisco Express Forwarding (CEF) or distributed CEF before configuring ATM AAL5, ATM Cell Relay, or Ethernet over MPLS. Enable and configure CEF before configuring Frame Relay, HDLC, or PPP over MPLS.

Configuration Tasks

Perform the following configuration tasks to enable AToM:

- [Step 1: Specify the Label Distribution Protocol](#) (required)
- [Step 2: Assign LDP Router IDs to the PE Routers](#) (required)
- [Step 3: Enable the PE Routers to Transport AToM Packets](#) (required)
- [Step 4: Configure the Customer CE Routers](#) (optional)

Step 1: Specify the Label Distribution Protocol

To specify the label distribution protocol for this interface, issue the following command. If you do not specify LDP, tag distribution protocol (TDP) is used instead.

```
Router(config)# mpls label protocol ldp
```

Step 2: Assign LDP Router IDs to the PE Routers

To assign LDP router IDs to the PE routers, perform the following steps. Both PE routers require a loopback address that you can use to create a virtual circuit (VC) between the routers.

Step 1 Enter interface configuration mode by using the following command:

```
Router(config)# interface loopback0
```

Step 2 Assign an IP address to the loopback interface. The LDP router ID must be configured with a 32-bit mask to ensure proper operation of MPLS forwarding between PE routers.

```
Router(config-if)# ip address ip-address
```

Step 3 Force the loopback IP address to be used as the router ID. You must assign an LDP router ID to each PE router. The **mpls ldp router-id** command allows you to specify which interface's IP address to use as the router ID. The **force** keyword guarantees that the PE routers are correctly targeting the appropriate router ID. If you do not use the **force** keyword, the router might assign a different router ID, which can prevent the establishment of VCs between PE routers.

```
Router(config)# mpls ldp router-id loopback0 force
```

Step 3: Enable the PE Routers to Transport AToM Packets

In general, the steps for configuring a PE router so that it can transport Layer 2 packets include:

-
- Step 1** Choose which interface will transport the packets with the **interface** command.
- Step 2** Specify the type of encapsulation you want on the interface with the **encapsulation** command.
- Step 3** Enable the local and remote PE router to establish a virtual circuit with the **mpls l2transport route** command. On each PE router, specify the loopback address of the remote PE router at the other end of the VC. You also assign a number to the VC, called a VC ID. Specify the same VC ID on both ends of the VC. On a PE router, the destination and vc-id pair must be unique. See the **mpls l2transport route** command for more information.
-

Each transport type might require some additional commands, which are detailed in the following sections:

- [Enable PE Routers to Transport ATM AAL5 SDUs and ATM Cell Relay Packets, page 29](#)
- [Enable PE Routers to Transport Ethernet Packets, page 29](#)
- [Enable PE Routers with DLCI-to-DLCI Connections to Transport Frame Relay Packets, page 30](#)
- [Enable PE Routers to Transport Frame Relay with Port-to-Port Connections, HDLC over MPLS, and PPP over MPLS Packets, page 31](#)
- [Enable Other PE Devices to Transport Frame Relay Packets, page 31](#)

Enable PE Routers to Transport ATM AAL5 SDUs and ATM Cell Relay Packets

In this release, the ATM Cell Relay features transports only a single cell. You must configure ATM Cell Relay on the permanent virtual circuits. ATM Cell Relay over MPLS supports only PVC mode, single cell relay.

	Command	Purpose
Step 1	Router(config)# interface atm <i>x/x</i>	Specifies an ATM interface.
Step 2	Router(config-atm-vc)# pvc vpi/vci l2transport	Assigns a virtual path identifier (VPI) and virtual circuit identifier (VCI). The l2transport keyword indicates that the PVC is a switched PVC instead of a terminated PVC. You can configure ATM AAL5 and ATM Cell Relay over MPLS on permanent virtual circuits (PVCs) only. You cannot configure AAL5 over MPLS on main interfaces.
Step 3	For ATM AAL5: Router(config-atm-vc)# encapsulation aa15 For ATM Cell Relay: Router(config-atm-vc)# encapsulation aa10	For ATM AAL5, this command specifies ATM AAL5 encapsulation for the interface. For ATM Cell Relay, this command specifies raw cell encapsulation for the interface. Make sure you specify the same encapsulation type on the PE and CE routers.
Step 4	Router(config-atm-vc)# mpls l2transport route destination vc-id	Creates the VC to transport the Layer 2 packets.

Enable PE Routers to Transport Ethernet Packets

On the the Cisco 7200 and 7500 series routers, you must configure Ethernet over MPLS on the subinterfaces.

	Command	Purpose
Step 1	Router(config-if)# interface GigabitEthernet x/x.x	Specifies the GigabitEthernet subinterface. Make sure the subinterface on the adjoining CE router is on the same VLAN as this PE router.
Step 2	Router(config-subif)# encapsulation dot1q <i>vlan-id</i>	Enables the subinterface to accept 802.1Q VLAN packets. The interfaces/subinterfaces between the CE and PE routers that are running Ethernet over MPLS must be in the same VLAN and subnet. All other interfaces/subinterfaces and backbone routers do not.
Step 3	Router(config-subif)# mpls l2transport route <i>destination vc-id</i>	Creates the VC to transport the VLAN packets.

Enable PE Routers with DLCI-to-DLCI Connections to Transport Frame Relay Packets

	Command	Purpose
Step 1	Router(config)# frame-relay switching	Enable permanent virtual circuit (PVC) switching on a Frame Relay device.
Step 2	Router(config)# interface Serial x/x	Specifies a serial interface.
Step 3	Router(config-if)# encapsulation frame-relay <i>frame-relay-type</i>	Specifies Frame Relay encapsulation for the interface. You can specify different types of encapsulations. You can set one interface to Cisco encapsulation and the other interface to IETF encapsulation.
Step 4	Router(config-if)# frame-relay intf-type dce	Specifies that the interface is a DCE switch. You can also specify the interface to support NNI and DTE connections.
Step 5	Router(config)# connect <i>connection-name</i> <i>interface dlci</i> l2transport	Defines connections between Frame Relay PVCs. Using the l2transport keyword specifies that the PVC will not be a locally switched PVC, but will be tunneled over the backbone network. The argument <i>connection-name</i> is a text string that you provide. The argument <i>interface</i> is the interface on which a PVC connection will be defined. The argument <i>dlci</i> is the data-link connection identifier (DLCI) number of the PVC that will be connected.
Step 6	Router(config-fr-pw-switching)# mpls l2transport route <i>destination vc-id</i>	Creates the VC to transport the Layer 2 packets. In a DLCI-to DLCI connection type, Frame Relay over MPLS uses the mpls l2transport route command in connect submenu.

Enable PE Routers to Transport Frame Relay with Port-to-Port Connections, HDLC over MPLS, and PPP over MPLS Packets

Use the following steps to set up any of the following transport types:

- Frame Relay Port-to-Port: When you set up a port-to-port connection between PE routers, you use HDLC mode to transport the Frame Relay encapsulated packets.
- HDLC
- PPP

	Command	Purpose
Step 1	Router(config)# interface Serialx/x	Specifies a serial interface. You must configure HDLC and PPP over MPLS on router interfaces only. You cannot configure HDLC over MPLS on subinterfaces.
Step 2	For Frame Relay Port-to-Port or HDLC encapsulation: Router(config-if)# encapsulation hdlc For PPP encapsulation: Router(config-if)# encapsulation ppp	For Frame Relay port-to-port encapsulation, this command transports Frame Relay packets in an HDLC packet. Otherwise, the packet is encapsulation as an HDLC or PPP packet.
Step 3	Router(config-fr-pw-switching)# mpls 12transport route destination vc-id	Creates the VC to transport the Layer 2 packets.

Enable Other PE Devices to Transport Frame Relay Packets

You can configure an interface as a DTE device or a DCE switch, or as a switch connected to a switch with NNI connections. Use the following command in interface configuration mode:

frame-relay intf-type [dce | dte | nni]

The keywords are explained in the following table:

Keyword	Description
dce	Enables the router or access server to function as a switch connected to a router.
dte	Enables the router or access server to function as a DTE device. DTE is the default.
nni	Enables the router or access server to function as a switch connected to a switch.

Step 4: Configure the Customer CE Routers

This section explains how to configure the customer CE router to transport Layer 2 packets. If the customer CE routers are configured to accept Layer 2 packets, these steps are not necessary.

In general, you use the following steps to configure the CE router. Each transport type might require some additional commands, which are detailed in the following sections.

	Command	Purpose
Step 1	Router(config)# interface <i>interface</i>	Specifies an interface.
Step 2	Router(config-atm-vc)# encapsulation <i>encapsulation type</i>	Specifies encapsulation for the interface.

Configure CE Routers for ATM AAL5 over MPLS

To configure the CE routers for ATM AAL5 over MPLS, make sure you specify the same encapsulation type on the PE and CE routers.

```
Router(config)# interface atmx/x
Router(config-if)# pvc vpi/vci
Router(config-atm-vc)# encapsulation aal5
```



Note CE devices can also be switches.

Configure CE Routers for ATM Cell Relay over MPLS

To configure the CE routers for ATM Cell Relay over MPLS, make sure the CE routers have the same encapsulation type. However, the PE and CE routers can have different encapsulation types.

```
Router(config)# interface atmx/x
Router(config-if)# pvc vpi/vci
Router(config-atm-vc)# encapsulation aal5
```



Note CE devices can also be switches.

Configure CE Routers for Ethernet over MPLS

To configure the CE routers for Ethernet over MPLS, make sure the interfaces/subinterfaces on the CE routers connected to the PE routers share the same VLAN ID and are in the same subnet.

```
Router(config-if)# interface GigabitEthernet x/x.x
Router(config-subif)# encapsulation dot1Q vlan-id
Router(config-subif)# ip address ip-address
```

Configure CE Routers for Frame Relay over MPLS

To configure the CE routers for Frame Relay over MPLS, make sure the following conditions are met:

- For DLCI-to-DLCI connections, the interfaces between the CE and PE routers must use the same LMI type. The CE routers must use the same encapsulation type.
- For port-to-port connections, all the routers (PE and CE) must have the same type of LMI, encapsulation, and interface. The CE routers must be configured as either DCE-DTE or NNI-NNI.

- In this procedure, the CE device is a router. The CE device can also be a Frame Relay switch.

The following example configures the CE routers for Frame Relay.

```
Router(config)# interface Serialx/x
Router(config-if)# encapsulation frame-relay [ietf]
```

Configure CE Routers for HDLC over MPLS

To configure the CE routers for HDLC over MPLS, if you configure keep-alive functionality, make sure that both CE router interfaces have keep-alives enabled with similar settings.

```
Router(config)# interface Serialx/x
Router(config-if)# encapsulation hdlc
Router(config-if)# ip address ip-address
```



Note

HDLC is the default encapsulation, so you do not have to enter the **encapsulation** command.

Configure CE Routers for PPP over MPLS

To configure the CE routers for PPP over MPLS, make sure the connections between the CE and PE routers on both ends of the backbone have similar link layer characteristics. The connections between the CE and PE routers must both be asynchronous or synchronous.

```
Router(config)# interface Serialx/x
Router(config-if)# encapsulation ppp
Router(config-if)# ip address ip-address
```

Verification Tasks

Perform the following tasks to verify that AToM is properly configured on the network:

- [Verify Connectivity Between the PE Routers, page 34](#)
- [Verify Connectivity Between the P and PE Routers, page 35](#)
- [Verify Connectivity Between the PE and CE Routers, page 36](#)

The following sections show the commands that help to verify the configuration of AToM. The verification procedures are based on the topology used in [Figure 8](#).

Figure 8 Configuration Used for Verification

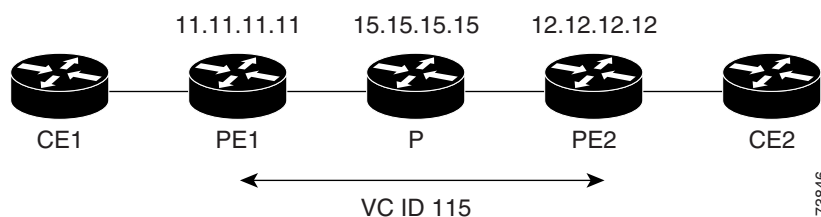

Verify Connectivity Between the PE Routers

Use the following commands on each PE router to ensure that the PE routers are working properly:

- Step 1** To make sure the PE router endpoints have discovered each other, use the **show mpls ldp discovery** command. The command output shows that PE1 established a targeted LDP session with PE2.

```
PE1# show mpls ldp discovery
```

```
Local LDP Identifier:
 11.11.11.11:0
Discovery Sources:
 Interfaces:
   POS6/0 (ldp): xmit/recv
     LDP Id: 15.15.15.15:0
 Targeted Hellos:
   11.11.11.11 -> 12.12.12.12 (ldp): active, xmit/recv
     LDP Id: 12.12.12.12:0
```

- Step 2** Use the **show mpls l2transport vc** command to check that a VC (with VC ID 115) has been established between the PE routers and that the VC is operational.

```
PE1# show mpls l2transport vc
```

Local intf	Local circuit	Dest address	VC ID	Status
AT1/0	ATM AAL5 0/115	12.12.12.12	115	UP

Step 3 To make sure the label distribution session has been established, use the **show mpls ldp neighbors** command. The output shows that:

- PE1 and PE2 have established a targeted LDP session.
- The LDP session is operational.
- Messages are being sent and received.

```
PE1# show mpls ldp neighbor
```

```
Peer LDP Ident: 15.15.15.15:0; Local LDP Ident 11.11.11.11:0
  TCP connection: 15.15.15.15.11072 - 11.11.11.11.646
  State: Oper; Msgs sent/rcvd: 65/73; Downstream
  Up time: 00:43:02
  LDP discovery sources:
    POS6/0, Src IP addr: 30.5.0.2
  Addresses bound to peer LDP Ident:
    8.0.5.4          180.3.0.3          15.15.15.15          30.5.0.2
    30.5.0.3
Peer LDP Ident: 12.12.12.12:0; Local LDP Ident 11.11.11.11:0
  TCP connection: 12.12.12.12.11000 - 11.11.11.11.646
  State: Oper; Msgs sent/rcvd: 26/25; Downstream
  Up time: 00:10:35
  LDP discovery sources:
    Targeted Hello 11.11.11.11 -> 12.12.12.12, active
  Addresses bound to peer LDP Ident:
    8.0.6.3          12.12.12.12          30.5.0.4
```

Step 4 To make sure the label forwarding table is built correctly, use the **show mpls forwarding-table** command. The output shows the following data:

- Local tag—Label assigned by this router.
- Outgoing tag or VC—Label assigned by next hop, or VPI/VCI used to get to next hop.
- Prefix or Tunnel Id—Address or tunnel to which AAL5 PDUs with this label are going.
- Bytes tag switched— Number of bytes switched with this incoming label.
- Outgoing interface—Interface through which AAL5 PDUs with this label are sent.
- Next Hop—IP address of neighbor that assigned the outgoing label.

```
PE1# show mpls forwarding-table
```

Local tag	Outgoing tag or VC	Prefix or Tunnel Id	Bytes tag switched	Outgoing interface	Next Hop
16	16	12.12.12.12/32	0	PO6/0	point2point
17	Pop tag	15.15.15.15/32	0	PO6/0	point2point
28	Untagged	l2ckt(115)	1120	AT1/0	point2point

Verify Connectivity Between the P and PE Routers

Use the following commands to ensure that the P router is correctly configured:

Step 1 Use the **show mpls ldp discovery** command to ensure that an LDP session exists. The command output shows that the P router has regular LDP sessions with the PE routers, not targeted LDP sessions.

```
P# show mpls ldp discovery
```

```

Local LDP Identifier:
  15.15.15.15:0
Discovery Sources:
Interfaces:
  POS3/0 (ldp): xmit/rcv
    LDP Id: 11.11.11.11:0
  POS6/0 (ldp): xmit/rcv
    LDP Id: 12.12.12.12:0
Targeted Hellos:
  15.15.15.15 -> 11.11.11.11 (ldp): active, xmit

```

Step 2 To make sure the label distribution session has been established, use the **show mpls ldp neighbors** command. The output shows that:

- The P router has LDP sessions with PE1 and PE2.
- The LDP session is operational.
- Messages are being sent and received.

```
P# show mpls ldp neighbors
```

```

Peer LDP Ident: 11.11.11.11:0; Local LDP Ident 15.15.15.15:0
TCP connection: 11.11.11.11.646 - 15.15.15.15.11072
State: Oper; Msgs sent/rcvd: 80/71; Downstream
Up time: 00:48:50
LDP discovery sources:
  POS3/0, Src IP addr: 30.5.0.1
Addresses bound to peer LDP Ident:
  8.0.5.20      11.11.11.11      180.3.0.2      20.20.20.3
  200.200.200.5  30.5.0.1
Peer LDP Ident: 12.12.12.12:0; Local LDP Ident 15.15.15.15:0
TCP connection: 12.12.12.12.646 - 15.15.15.15.11169
State: Oper; Msgs sent/rcvd: 29/27; Downstream
Up time: 00:16:28
LDP discovery sources:
  POS6/0, Src IP addr: 30.5.0.4
Addresses bound to peer LDP Ident:
  8.0.6.3      12.12.12.12      30.5.0.4

```

Step 3 To make sure the label forwarding table is built correctly, use the **show mpls forwarding-table** command.

```
P# show mpls forwarding-table
```

Local tag	Outgoing tag or VC	Prefix or Tunnel Id	Bytes tag switched	Outgoing interface	Next Hop
16	Pop tag	12.12.12.12/32	18030	PO6/0	point2point
19	Pop tag	11.11.11.11/32	18609	PO3/0	point2point

Verify Connectivity Between the PE and CE Routers

ATM AAL5 and ATM Cell Relay

Use the **show atm vc** command on CE1 and CE2 to ensure that the ATM AAL5 VC is active.

```
CE# show atm vc
```

Interface	VCD / Name	VPI	VCI	Type	Encaps	SC	Peak Kbps	Avg/Min Kbps	Burst Cells	Sts
-----------	------------	-----	-----	------	--------	----	-----------	--------------	-------------	-----

```
2/0/0.3    11          0    115 PVC    AAL5    UBR  149760          UP
```

Ethernet over MPLS

Issue the **show ip interface brief** command on the CE routers. If the interface can provide two-way communication, the Protocol field is marked “up.” If the interface hardware is usable, the Status field is marked “up.”

```
Router# show ip interface brief
```

Interface	IP-Address	OK?	Method	Status	Protocol
Vlan2	10.1.2.58	YES	NVRAM	up	up
Vlan4	unassigned	YES	NVRAM	up	up
Vlan101	unassigned	YES	NVRAM	up	up
GigabitEthernet6/0	172.31.255.255	YES	NVRAM	administratively down	down
GigabitEthernet1/0	unassigned	YES	NVRAM	administratively down	down
GigabitEthernet3/0	172.31.255.255	YES	NVRAM	up	up
GigabitEthernet4/0	unassigned	YES	NVRAM	administratively down	down
Loopback0	172.16.0.0	YES	NVRAM	up	up

Frame Relay over MPLS

Use the **show frame-relay pvc** command on CE1 and CE2 to ensure that the DLCI is active. The line in the middle of the command output shows that DLCI 1002 is active.

```
CE1# show frame-relay pvc
```

```
PVC Statistics for interface POS2/1/0 (Frame Relay DTE)
```

	Active	Inactive	Deleted	Static
Local	1	0	0	0
Switched	0	0	0	0
Unused	0	0	0	0

```
DLCI = 1002, DLCI USAGE = LOCAL, PVC STATUS = ACTIVE, INTERFACE = POS2/1/0.2
```

```
input pkts 31          output pkts 29          in bytes 6555
out bytes 6194        dropped pkts 0          in FECN pkts 0
in BECN pkts 0       out FECN pkts 0        out BECN pkts 0
in DE pkts 0          out DE pkts 0
out bcast pkts 14    out bcast bytes 4634
pvc create time 00:16:43, last time pvc status changed 00:13:54
```

HDLC and PPP over MPLS

Use the **show ip interface brief** command on CE1 and CE2 to make sure the router interfaces are operating.

```
CE1# show ip interface brief
```

Interface	IP-Address	OK?	Method	Status	Protocol
Serial1/1	11.11.11.11	YES	unset	up	up
Serial2/1	12.12.12.12	YES	unset	up	up
Hssi1/1	10.10.10.10	YES	unset	up	up

Enabling OAM Cell Emulation for ATM AAL5 over MPLS

To enable OAM cell emulation on the PE routers, issue the **oam-ac emulation-enable** command in AToM VC configuration mode. The following example shows how to enable OAM cell emulation on an ATM PVC.

```
Router# interface ATM 1/0/0
Router(config-if)# pvc 1/200 l2transport
Router(config-atm-vc)# oam-ac emulation-enable
```

Specify the Rate at Which AIS Cells Are Sent

The `oam-ac emulation-enable` command lets you specify the rate at which AIS cells are sent. The default is one cell every second. The range is 0 to 60 seconds. The following example sets the rate at which an AIS cell is sent to every 30 seconds:

```
Router(config-atm-vc)# oam-ac emulation-enable 30
```

See the `oam-ac emulation-enable` command for more information.

Troubleshooting Tasks

If packets are being dropped when traveling from the CE routers, through the core, and to their destination, you might need to set the maximum transmission unit (MTU) size on the core (P and PE) routers to accommodate all packets. The following sections help you determine the MTU size.

Estimating the Size of Packets Traveling Through the Core Network

The following calculation helps you determine the size of the packets traveling through the core network. You set the MTU on the core-facing interfaces of the P and PE routers to accommodate packets of this size. The MTU should be greater than or equal to the total bytes of the items in the following equation:

```
Core MTU >= (Edge MTU + Transport header + AToM header + (MPLS label stack * MPLS label size))
```

The following sections describe the variables used in the equation.

Edge MTU

The edge MTU is the MTU for the customer-facing interfaces.

Transport header

The Transport header depends on the transport type. [Table 5](#) lists the specific sizes of the headers.

Table 5 Header Size of Packets

Transport Type	Packet Size
AAL5	0 - 32 bytes
Ethernet VLAN	18 bytes
Frame Relay DLCI	2 bytes for Cisco encapsulation, 8 bytes for IETF encapsulation.
HDLC	4 bytes
PPP	4 bytes

AToM Header

The AToM header is 4 bytes (control word). The control word is optional for Ethernet, PPP, HDLC, and cell relay transport types. However, the control word is required for Frame Relay, and ATM AAL5 transport types.

MPLS Label Stack

The MPLS label stack size depends on the configuration of the core MPLS network.

- AToM uses one MPLS label to identify the ATOM VCs (VC label). Therefore, the minimum MPLS label stack is 1 for directly connected ATOM PEs, which are PE routers that do not have a P router between them.
- If LDP is used in the MPLS network, the label stack size is 2 (the LDP label and the VC label).
- If a TE tunnel instead of LDP is used between PE routers in the MPLS network, the label stack size is 2 (the TE label and the VC label).
- If a TE tunnel and LDP are used in the MPLS network (for example, a TE tunnel between P routers or between P and PE routers, with LDP on the tunnel), the label stack is 3 (TE label, LDP label, VC label).
- If you use MPLS Fast Reroute in the MPLS network, you add a label to the stack. The maximum MPLS label stack in this case is 4 (FRR label, TE label, LDP label, VC label).
- If AToM is used by the customer carrier in MPLS-VPN Carrier Supporting Carrier environment, you add a label to the stack. The maximum MPLS label stack in the provider carrier network is 5 (FRR label, TE label, LDP label, VPN label, VC label).
- If an AToM tunnel spans different service providers that exchange MPLS labels using IPv4 BGP (RFC 3107), you add a label to the stack. The maximum MPLS label stack is 5 (FRR label, TE label, BGP label, LDP label, VC label).

Other circumstances can increase the MPLS label stack size. Therefore, analyze the complete data path between the AToM tunnel endpoints and determine the maximum MPLS label stack size for your network. Then multiply the label stack size by the size of the MPLS label.

Example of Estimating Packet Size

Example 1 estimates the size of packets. The example uses the following assumptions:

- The edge MTU is 1500 bytes.
- The transport type is Ethernet, which designates 18 bytes for the transport header.
- The AToM header is 0, because the control word is not used.
- The MPLS label stack is 2, because LDP is used. The MPLS label is 4 bytes.

Example 1 Estimating the MTU for Packets

```
Edge MTU + Transport header + AToM header + (MPLS label stack * MPLS Label) = Core MTU
1500      + 18                + 0          + (2          * 4          ) = 1526
```

You must configure the P and PE routers in the core to accept packets of 1526 bytes. See the following section for setting the MTU size on the P and PE routers.

Changing the MTU Size on the P and PE Routers

Once you determine the MTU size to set on your P and PE routers, you can issue the **mtu** command on the routers to set the MTU size. The following example specifies an MTU of 1526 bytes.

```
Router(config-if)# mtu 1526
```

**Note**

Some interfaces (such as FastEthernet interfaces) require the **mpls mtu** command to change the MTU size.

Configuration Examples

This section includes the following configuration examples:

- [ATM AAL5 over MPLS Configuration Example, page 41](#)
- [ATM Cell Relay over MPLS Configuration Example, page 42](#)
- [Ethernet over MPLS Configuration Example, page 42](#)
- [Frame Relay over MPLS Configuration Example, page 43](#)
- [HDLC over MPLS Configuration Example, page 44](#)
- [PPP over MPLS Configuration Example, page 45](#)

These configuration examples use the network configuration in [Figure 9](#).

Figure 9 Sample Network Configuration

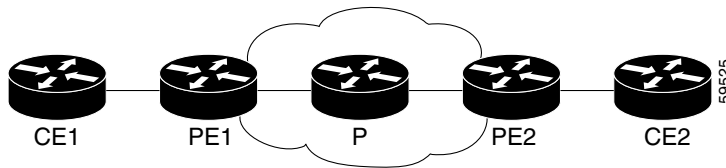

ATM AAL5 over MPLS Configuration Example

[Table 6](#) shows an AAL5 over MPLS configuration example.

Table 6 AAL5 over MPLS Configuration Example

PE1	PE2
<pre> mpls label protocol ldp mpls ldp router-id Loopback0 force ! interface Loopback0 ip address 11.11.11.11 255.255.255.255 interface ATM4/0 pvc 0/100 l2transport encapsulation aal5 mpls l2transport route 12.12.12.12 100 ! interface ATM4/0.300 point-to-point pvc 0/300 l2transport encapsulation aal5 mpls l2transport route 12.12.12.12 300 </pre>	<pre> mpls label protocol ldp mpls ldp router-id Loopback0 force ! interface Loopback0 ip address 12.12.12.12 255.255.255.255 interface ATM4/0 pvc 0/100 l2transport encapsulation aal5 mpls l2transport route 11.11.11.11 100 ! interface ATM4/0.300 point-to-point pvc 0/300 l2transport encapsulation aal5 mpls l2transport route 11.11.11.11 300 </pre>

ATM Cell Relay over MPLS Configuration Example

Table 7 shows an ATM Cell Relay over MPLS configuration example. In this release, ATM Cell Relay over MPLS supports only single cell relay over PVC circuits.

Table 7 ATM Cell Relay over MPLS Configuration Example

PE1	P 2
<pre> mpls label protocol ldp mpls ldp router-id Loopback0 force ! interface Loopback0 ip address 12.12.12.12 255.255.255.255 interface ATM4/0 pvc 0/100 l2transport encapsulation aal0 mpls l2transport route 13.13.13.13 100 ! interface ATM4/0.300 point-to-point no ip directed-broadcast no atm enable-ilmi-trap pvc 0/300 l2transport encapsulation aal0 mpls l2transport route 13.13.13.13 300 </pre>	<pre> mpls label protocol ldp mpls ldp router-id Loopback0 force ! interface Loopback0 ip address 13.13.13.13 255.255.255.255 interface ATM4/0 pvc 0/100 l2transport encapsulation aal0 mpls l2transport route 12.12.12.12 100 ! interface ATM4/0.300 point-to-point no ip directed-broadcast no atm enable-ilmi-trap pvc 0/300 l2transport encapsulation aal0 mpls l2transport route 12.12.12.12 300 </pre>

Ethernet over MPLS Configuration Example

Table 8 shows an Ethernet over MPLS example

Table 8 Ethernet over MPLS Configuration Example

PE1	PE2
<pre> mpls label protocol ldp mpls ldp router-id Loopback0 force ! interface Loopback0 ip address 11.11.11.11 255.255.255.255 ! interface ATM2/0.1 tag-switching ip unnumbered Loopback0 no ip directed-broadcast no atm enable-ilmi-trap mpls label protocol ldp mpls atm vpi 2-5 mpls ip ! interface GigabitEthernet4/0.1 encapsulation dot1Q 1000 no ip directed-broadcast mpls l2transport route 12.12.12.12 100 </pre>	<pre> mpls label protocol ldp mpls ldp router-id Loopback0 force ! interface Loopback0 ip address 12.12.12.12 255.255.255.255 ! interface ATM1/0.1 tag-switching ip unnumbered Loopback0 no ip directed-broadcast no atm enable-ilmi-trap mpls label protocol ldp mpls atm vpi 2-5 mpls ip ! interface GigabitEthernet5/0.1 encapsulation dot1Q 1000 no ip directed-broadcast mpls l2transport route 11.11.11.11 100 </pre>

Frame Relay over MPLS Configuration Example

Table 9 shows a Frame Relay over MPLS configuration example.

Table 9 Frame Relay over MPLS Configuration Example

PE1	PE2
<pre> frame-relay switching mpls label protocol ldp mpls ldp router-id Loopback0 force mpls ip ! interface Loopback0 ip address 13.13.13.13 255.255.255.255 ! interface Serial5/0 encapsulation frame-relay IETF load-interval 30 clockrate 124061 frame-relay lmi-type cisco frame-relay intf-type dce ! interface ATM6/0.1 point-to-point ip address 2.0.0.2 255.0.0.0 pvc 1/34 ! router ospf 10 log-adjacency-changes auto-cost reference-bandwidth 100000 network 2.0.0.0 0.255.255.255 area 100 network 13.13.13.13 0.0.0.0 area 100 ! connect fr1 Serial5/0 1000 l2transport mpls l2transport route 11.11.11.11 303 </pre>	<pre> frame-relay switching mpls label protocol ldp mpls ldp router-id Loopback0 force mpls ip ! interface Loopback0 ip address 11.11.11.11 255.255.255.255 ! interface Serial2/0/3 encapsulation frame-relay IETF clockrate 124061 cdp enable frame-relay lmi-type cisco frame-relay intf-type dce ! interface ATM1/0/0.1 point-to-point ip address 1.0.0.1 255.0.0.0 pvc 1/33 ! router ospf 10 log-adjacency-changes auto-cost reference-bandwidth 100000 network 1.0.0.0 0.255.255.255 area 100 network 11.11.11.11 0.0.0.0 area 100 ! connect fr2 Serial2/0/3 102 l2transport mpls l2transport route 13.13.13.13 303 </pre>

HDLC over MPLS Configuration Example

Table 10 shows an HDLC over MPLS configuration example.

Table 10 HDLC over MPLS Configuration Example

PE1	PE2
<pre> ip routing ! hostname pe1 ! ip cef accounting per-prefix ip cef load-sharing algorithm original ! mpls label protocol ldp mpls ldp router-id Loopback0 force ! interface Loopback0 ip address 8.8.8.8 255.255.255.255 no ip directed-broadcast ! interface POS0/0 no ip address no ip directed-broadcast no keepalive encapsulation hdlc mpls l2transport route 9.9.9.9 50 crc 32 clock source internal ! router ospf 10 log-adjacency-changes auto-cost reference-bandwidth 1000 network 8.8.8.8 0.0.0.0 area 0 network 24.1.1.8 0.0.0.0 area 0 </pre>	<pre> ip routing ! hostname pe2 ! ip cef accounting per-prefix ip cef load-sharing algorithm original ! mpls label protocol ldp mpls ldp router-id Loopback0 force ! interface Loopback0 ip address 9.9.9.9 255.255.255.255 no ip directed-broadcast ! interface POS0/0 no ip address no ip directed-broadcast no keepalive encapsulation hdlc mpls l2transport route 8.8.8.8 50 crc 32 clock source internal ! router ospf 10 log-adjacency-changes auto-cost reference-bandwidth 1000 network 9.9.9.9 0.0.0.0 area 0 network 46.1.1.6 0.0.0.0 area 0 </pre>

PPP over MPLS Configuration Example

Table 11 shows a PPP over MPLS configuration example.

Table 11 PPP over MPLS Configuration Example

PE1	PE2
<pre> ip routing ! hostname pe1 ! ip subnet-zero ip cef accounting per-prefix ! mpls label protocol ldp mpls ldp router-id Loopback0 force ! interface Loopback0 ip address 8.8.8.8 255.255.255.255 no ip directed-broadcast ! interface POS0/0 no ip address no ip directed-broadcast no keepalive encapsulation ppp mpls l2transport route 9.9.9.9 50 crc 32 clock source internal ! interface POS0/1 ip address 24.1.1.8 255.255.255.0 no ip directed-broadcast no keepalive mpls label protocol ldp mpls ip crc 32 ! router ospf 10 log-adjacency-changes auto-cost reference-bandwidth 1000 network 8.8.8.8 0.0.0.0 area 0 network 24.1.1.8 0.0.0.0 area 0 </pre>	<pre> ip routing ! hostname pe2 ! ip cef accounting per-prefix ip cef load-sharing algorithm original ! mpls label protocol ldp mpls ldp router-id Loopback0 force ! interface Loopback0 ip address 9.9.9.9 255.255.255.255 no ip directed-broadcast ! interface POS0/0 no ip address no ip directed-broadcast no keepalive encapsulation ppp mpls l2transport route 8.8.8.8 50 crc 32 clock source internal ! interface POS0/1 ip address 46.1.1.6 255.255.255.0 no ip directed-broadcast no keepalive mpls label protocol ldp mpls ip crc 32 ! router ospf 10 log-adjacency-changes auto-cost reference-bandwidth 1000 network 9.9.9.9 0.0.0.0 area 0 network 46.1.1.6 0.0.0.0 area 0 </pre>

What To Do Next

See the following MPLS AToM documentation for more information:

- *Start Here: MPLS AToM: Transport, Platform, and Release Specifics*
- *MPLS AToM: Overview*
- *MPLS AToM: Commands*



MPLS AToM — Commands

This document contains new and revised commands for the MPLS AToM. All other commands used with MPLS AToM are documented in the Cisco IOS Release 12.2 command reference publications.

The following sections are included in this document:

- [Documentation Specifics](#)
- [New and Revised Commands](#)

Documentation Specifics

This documentation set includes the following sections:

- *Start Here: MPLS AToM: Transport, Platform, and Release Specifics*
- *MPLS AToM: Overview*
- *MPLS AToM: Configuring*
- *MPLS AToM: Commands* (this document)



Note

Start Here: MPLS AToM: Transport, Platform, and Release Specifics details the features that are supported in each release and on each platform. Not all MPLS AToM features are supported in each Cisco IOS software release for each platform. Read the entire chapter before reading the other chapters.

The other chapters provide overview, configuration, and command reference information for MPLS AToM features.

New and Revised Commands

- [connect \(Frame Relay\)](#)
- [debug acircuit](#)
- [debug condition](#)
- [debug frame-relay events](#)
- [debug mpls l2transport ipc](#)
- [debug mpls l2transport packet](#)

- `debug mpls l2transport signaling`
- `debug mpls l2transport vc`
- `encapsulation (Any Transport over MPLS)`
- `mpls l2transport route`
- `oam-ac emulation-enable`
- `pvc`
- `show atm pvc`
- `show mpls l2transport binding`
- `show mpls l2transport hw-capability`
- `show mpls l2transport summary`
- `show mpls l2transport vc`

connect (Frame Relay)

To define connections between Frame Relay permanent virtual circuits (PVCs), use the **connect** command in global configuration mode. To remove connections, use the **no** form of this command.

```
connect connection-name interface dlc {interface dlc | l2transport}
```

```
no connect connection-name interface dlc {interface dlc | l2transport}
```

Syntax Description

<i>connection-name</i>	A name for this connection.
<i>interface</i>	Interface on which a PVC connection will be defined.
<i>dlci</i>	Data-link connection identifier (DLCI) number of the PVC that will be connected.
l2transport	Specifies that the PVC will not be a locally switched PVC, but will be tunneled over the backbone network.

Defaults

No default behavior or values.

Command Modes

Global configuration

Command History

Release	Modification
12.1(2)T	This command was introduced.
12.0(23)S	This command was updated with the l2transport keyword.
12.2(14)S	This command was integrated into Cisco IOS Release 12.2(14)S.
12.2(15)T	This command was integrated into Cisco IOS Release 12.2(15)T.

Usage Guidelines

When frame Relay switching is enabled, the **connect** command creates switched PVCs in Frame Relay networks.

Examples

The following example shows how to enable Frame Relay switching and define a connection called frompls1 with a DLCI 100 on serial interface 5/0.

```
PE1_router(config)# connect frompls1 Serial5/0 1000 l2transport
```

Related Commands

Command	Description
frame-relay switching	Enables PVC switching on a Frame Relay DCE or NNI.
mpls l2transport route	Enables routing of Frame Relay packets over a specified VC.

debug acircuit

To display errors and events that occur on the attachment circuits (the circuits between the provider edge (PE) and customer edge (CE) routers), use the **debug acircuit** command in privileged EXEC mode. To disable this debugging output, use the **no** form of this command.

debug acircuit {error | event}

no debug acircuit {error | event}

Syntax Description

error	Displays any errors that occurred on any of the attachment circuits.
event	Displays any event messages for the attachment circuits, including messages about state transitions, interface transitions, and message events.

Command Modes

Privileged EXEC

Command History

Release	Modification
12.0(23)S	This command was introduced.
12.2(14)S	This command was integrated into Cisco IOS Release 12.2(14)S.
12.2(15)T	This command was integrated into Cisco IOS Release 12.2(15)T.

Usage Guidelines

An attachment circuit connects a PE router to a CE router. A router can have many attachment circuits. The attachment circuit manager controls all the attachment circuits from one central location. Therefore, when you enable the debug messages for the attachment circuit, you receive information about all the attachment circuits.

Examples

The following is sample output from the **debug acircuit event** command when you enable an interface:

```
Router# debug acircuit event
```

```
*Jan 28 15:19:03.070: ACLIB: ac_cstate() Handling circuit UP for interface Se2/0
*Jan 28 15:19:03.070: ACLIB [11.0.1.1, 200]: pthru_intf_handle_circuit_up() calling
acmgr_circuit_up
*Jan 28 15:19:03.070: ACLIB [11.0.1.1, 200]: Setting new AC state to Ac-Connecting
*Jan 28 15:19:03.070: ACMGR: Receive <Circuit Up> msg
*Jan 28 15:19:03.070: Se2/0 ACMGR: circuit up event, SIP state chg down to connecting,
action is service request
*Jan 28 15:19:03.070: Se2/0 ACMGR: Sent a sip service request
*Jan 28 15:19:03.070: ACLIB [11.0.1.1, 200]: AC updating switch context.
*Jan 28 15:19:03.070: Se2/0 ACMGR: Rcv SIP msg: resp connect forwarded, hdl 9500001D,
l2ss_hdl 700001E
*Jan 28 15:19:03.070: Se2/0 ACMGR: service connected event, SIP state chg connecting to
connected, action is respond forwarded
*Jan 28 15:19:03.070: ACLIB: pthru_intf_response hdl is 9500001D, response is 1
*Jan 28 15:19:03.070: ACLIB [11.0.1.1, 200]: Setting new AC state to Ac-Connected
```

The following is sample output from the **debug acircuit event** command when you disable an interface:

```
Router# debug acircuit event
```

```
*Jan 28 15:25:57.014: ACLIB: SW AC interface INTF-DOWN for interface Se2/0
*Jan 28 15:25:57.014: ACLIB [11.0.1.1, 200]: Setting new AC state to Ac-Idle
*Jan 28 15:25:57.014: ACLIB: SW AC interface INTF-DOWN for interface Se2/0
*Jan 28 15:25:57.014: Se2/0 ACMGR: Receive <Circuit Down> msg
*Jan 28 15:25:57.014: Se2/0 ACMGR: circuit down event, SIP state chg connected to end,
action is service disconnect
*Jan 28 15:25:57.014: Se2/0 ACMGR: Sent a sip service disconnect
*Jan 28 15:25:57.014: ACLIB [11.0.1.1, 200]: AC deleting switch context.
*Jan 28 15:25:59.014: %LINK-5-CHANGED: Interface Serial2/0, changed state to
administratively down
*Jan 28 15:25:59.014: ACLIB: ac_cstate() Handling circuit DOWN for interface Se2/0
*Jan 28 15:26:00.014:%LINEPROTO-5-UPDOWN: Line protocol on Interface Serial2/0, changed
state to down
```

debug condition

To limit output for some debugging commands based on specified conditions, use the **debug condition** command in privileged EXEC mode. To removed the specified condition, use the **no** form of this command.

```
debug condition { username username | called dial-string | caller dial-string | vcid vc-id | ip
ip-address }
```

```
no debug condition { condition-id | all }
```

Syntax Description

username <i>username</i>	Generates debugging messages for interfaces with the specified username.
called <i>dial-string</i>	Generates debugging messages for interfaces with the called party number.
caller <i>dial-string</i>	Generates debugging messages for interfaces with the calling party number.
vcid <i>vc-id</i>	Generates debugging messages for the VC ID specified.
ip <i>ip-address</i>	Generates debugging messages for the IP address specified.
<i>condition-id</i>	Removes the condition indicated.
all	Removes all debugging conditions, and conditions specified by the debug condition interface command. Use this keyword to disable conditional debugging and reenable debugging for all interfaces.

Command Modes

Privileged EXEC

Command History

Release	Modification
11.3(2)AA	This command was introduced.
12.0(23)S	This command was integrated into Cisco IOS Release 12.0(23)S. This command was updated with the vcid and ip keywords to support the debugging of Any Transport over MPLS (AToM) messages.
12.2(14)S	This command was integrated into Cisco IOS Release 12.2(14)S.
12.2(15)T	This command was integrated into Cisco IOS Release 12.2(15)T.

Defaults

All debugging messages for enabled protocol-specific **debug** commands are generated.

Usage Guidelines

Use the **debug condition** command to restrict the debug output for some commands. If any **debug condition** commands are enabled, output is only generated for interfaces associated with the specified keyword. In addition, this command enables debugging output for conditional debugging events. Messages are displayed as different interfaces meet specific conditions.

If multiple **debug condition** commands are enabled, output is displayed if at least one condition matches. All the conditions do not need to match.

The **no** form of this command removes the debug condition specified by the condition identifier. The condition identifier is displayed after you use a **debug condition** command or in the output of the **show debug condition** command. If the last condition is removed, debugging output resumes for all interfaces. You will be asked for confirmation before removing the last condition or all conditions.

Not all debugging output is affected by the **debug condition** command. Some commands generate output whenever they are enabled, regardless of whether they meet any conditions. The commands that are affected by the **debug condition** commands are generally related to dial access functions, where a large amount of output is expected. Output from the following commands is controlled by the **debug condition** command:

- **debug aaa {accounting | authorization | authentication}**
- **debug dialer {events | packets}**
- **debug isdn {q921 | q931}**
- **debug modem {oob | trace}**
- **debug ppp {all | authentication | chap | error | negotiation | multilink events | packet}**

Examples

Example 1

In the following example, the router displays debugging messages only for interfaces that use a username of fred. The condition identifier displayed after the command is entered identifies this particular condition.

```
Router# debug condition username fred
Condition 1 set
```

Example 2

The following example specifies that the router should display debugging messages only for VC 1000:

```
Router# debug condition vcid 1000
Condition 1 set
01:12:32: 1000 Debug: Condition 1, vcid 1000 triggered, count 1
01:12:32: 1000 Debug: Condition 1, vcid 1000 triggered, count 1
```

Other debugging commands are enabled, but they will only display debugging for VC 1000.

```
Router# debug mpls l2transport vc event
AToM vc event debugging is on
Router# debug mpls l2transport vc fsm
AToM vc fsm debugging is on
```

The following commands shut down the interface where VC 1000 is established.

```
Router(config)# interface s3/1/0
Router(config-if)# shut
```

The debugging output shows the change to the interface where VC 1000 is established.

```
01:15:59: AToM MGR [13.13.13.13, 1000]: Event local down, state changed from established
to remote ready
01:15:59: AToM MGR [13.13.13.13, 1000]: Local end down, vc is down
01:15:59: AToM SMGR [13.13.13.13, 1000]: Processing imposition update, vc_handle 6227BCF0,
update_action 0, remote_vc_label 18
01:15:59: AToM SMGR [13.13.13.13, 1000]: Imposition Disabled
01:15:59: AToM SMGR [13.13.13.13, 1000]: Processing disposition update, vc_handle
6227BCF0, update_action 0, local_vc_label 755
01:16:01:%LINK-5-CHANGED: Interface Serial3/1/0, changed state to administratively down
01:16:02:%LINEPROTO-5-UPDOWN: Line protocol on Interface Serial3/1/0, changed state to
down
```

■ **debug condition**

Related Commands

Command	Description
debug condition interface	Limits output for some debugging commands based on the interfaces.

debug frame-relay events

To display debugging information about Frame Relay Address Resolution Protocol (ARP) replies on networks that support a multicast channel and use dynamic addressing, use the **debug frame-relay events** command in privileged EXEC mode. To disable debugging output, use the **no** form of this command.

debug frame-relay events

no debug frame-relay events

Syntax Description This command has no arguments or keywords.

Command Modes Privileged EXEC

Command History	Release	Modification
	11.3	This command was introduced.
	12.0(23)S	This command was integrated into Cisco IOS Release 12.0(23)S for the Frame Relay over MPLS feature.
	12.2(14)S	This command was integrated into Cisco IOS Release 12.2(14)S.
	12.2(15)T	This command was integrated into Cisco IOS Release 12.2(15)T.

Usage Guidelines This command is useful for identifying the cause of end-to-end connection problems during the installation of a Frame Relay network or node.



Note Because the **debug frame-relay events** command does not generate much output, you can use it at any time, even during periods of heavy traffic, without adversely affecting other users on the system.

Examples The following is sample output from the **debug frame-relay events** command:

```
Router# debug frame-relay events

Serial2(i): reply rcvd 172.16.170.26 126
Serial2(i): reply rcvd 172.16.170.28 128
Serial2(i): reply rcvd 172.16.170.34 134
Serial2(i): reply rcvd 172.16.170.38 144
Serial2(i): reply rcvd 172.16.170.41 228
Serial2(i): reply rcvd 172.16.170.65 325
```

As the output shows, the **debug frame-relay events** command returns one specific message type. The first line, for example, indicates that IP address 172.16.170.26 sent a Frame Relay ARP reply; this packet was received as input on serial interface 2. The last field (126) is the data-link connection identifier (DLCI) to use when communicating with the responding router.

For Frame Relay over MPLS, the following is sample output for the **debug frame-relay events** command. The command output shows the status of the VCs.

```
Router# debug frame-relay events
Frame Relay events debugging is on
```

This example shows the messages that are displayed when you shut the core-facing interface on a PE router:

```
04:40:38:%SYS-5-CONFIG_I: Configured from console by consolenf t
Enter configuration commands, one per line. End with CNTL/Z.
Router(config)# interface hssi2/0
Router(config-if)# shut

04:40:43:%OSPF-5-ADJCHG: Process 10, Nbr 12.12.12.12 on Hssi2/0 from FULL to DOWN,
Neighbor Down: Interface down or detached
04:40:43: FRoMPLS [12.12.12.12, 100]: PW pvc_status set INACTIVE
04:40:43: FRoMPLS [12.12.12.12, 100]: Setting pw segment DOWN
04:40:43: FRoMPLS [12.12.12.12, 100]: Setting connection DOWN
04:40:43: FRoMPLS [12.12.12.12, 101]: PW pvc_status set INACTIVE
04:40:43: FRoMPLS [12.12.12.12, 101]: Setting pw segment DOWN
04:40:43: FRoMPLS [12.12.12.12, 101]: Setting connection DOWN
04:40:45:%LINK-5-CHANGED: Interface Hssi2/0, changed state to administratively down
04:40:46:%LINEPROTO-5-UPDOWN: Line protocol on Interface Hssi2/0, changed state to down
```

This example shows the messages that are displayed when you enable the core-facing interface on a PE router:

```
Router(config-if)# no shut

04:40:56:%LINK-3-UPDOWN: Interface Hssi2/0, changed state to up
04:40:57:%LINEPROTO-5-UPDOWN: Line protocol on Interface Hssi2/0, changed state to up
04:41:06:%OSPF-5-ADJCHG: Process 10, Nbr 12.12.12.12 on Hssi2/0 from LOADING to FULL,
Loading Done
04:41:19: FRoMPLS [12.12.12.12, 100]: PW pvc_status set ACTIVE
04:41:19: FRoMPLS [12.12.12.12, 100]: Setting pw segment UP
04:41:19: FRoMPLS [12.12.12.12, 101]: PW pvc_status set ACTIVE
04:41:19: FRoMPLS [12.12.12.12, 101]: Setting pw segment UP
```

This example shows the messages that are displayed when you shut the edge-facing interface on a PE router:

```
Router(config)# interface pos4/0
Router(config-if)# shut

04:42:50: FRoMPLS [12.12.12.12, 100]: acmgr_circuit_down
04:42:50: FRoMPLS [12.12.12.12, 100]: Setting connection DOWN
04:42:50: FRoMPLS [12.12.12.12, 100]: PW pvc_status set INACTIVE
04:42:52:%LINK-5-CHANGED: Interface POS4/0, changed state to administratively down
04:42:53:%LINEPROTO-5-UPDOWN: Line protocol on Interface POS4/0, changed state to down
```

This example shows the messages that are displayed when you enable the edge-facing interface on a PE router:

```
Router(config)# interface pos4/0
Router(config-if)# no shut

04:43:20:%LINK-3-UPDOWN: Interface POS4/0, changed state to up
c72-33-2(config-if)#
04:43:20: FRoMPLS [12.12.12.12, 100]: Local up, sending acmgr_circuit_up
04:43:20: FRoMPLS [12.12.12.12, 100]: PW nni_pvc_status set ACTIVE
04:43:20: FRoMPLS [12.12.12.12, 100]: PW pvc_status set ACTIVE
04:43:20: FRoMPLS [12.12.12.12, 100]: Setting pw segment UP
```

debug mpls l2transport ipc

To display the interprocessor communication (IPC) messages exchanged between distributed platforms, such as the Cisco 12000 series router and the Cisco 7500 series routers, use the **debug mpls l2transport ipc** command in privileged EXEC mode. To disable this debugging output, use the **no** form of this command.

debug mpls l2transport ipc

no debug mpls l2transport ipc

Syntax Description This command has no arguments or keywords.

Command Modes Privileged EXEC

Command History	Release	Modification
	12.0(23)S	This command was introduced.
	12.2(14)S	This command was integrated into Cisco IOS Release 12.2(14)S.
	12.2(15)T	This command was integrated into Cisco IOS Release 12.2(15)T.

Usage Guidelines You can issue this command either from the line card or the route processor to log AToM updates to or from line cards. This command applies only to platforms that support distributed mode.

Examples The following is sample output from the **debug mpls l2transport ipc** command:

```
Router# debug mpls l2transport ipc
AToM ipc debugging is on
*May 27 23:56:04.699 UTC: AToM SMGR: Repopulating line card 255
*May 27 23:56:04.699 UTC: AToM SMGR [17.17.17.17, 1101]: Sending Imposition update to slot
255
*May 27 23:56:04.699 UTC: AToM SMGR [17.17.17.17, 1101]: Imposition being done on ingress
interface
*May 27 23:56:04.699 UTC: AToM SMGR [17.17.17.17, 1101]: Sending disposition update to
slot 255
*May 27 23:56:04.699 UTC: AToM SMGR [17.17.17.17, 1101]: Distributing disposition info to
all linecards
*May 27 23:56:04.699 UTC: AToM SMGR [17.17.17.17, 701]: Sending Imposition update to slot
255
*May 27 23:56:04.699 UTC: AToM SMGR [17.17.17.17, 701]: Imposition being done on ingress
interface
*May 27 23:56:04.699 UTC: AToM SMGR [17.17.17.17, 701]: Sending disposition update to slot
255
*May 27 23:56:04.699 UTC: AToM SMGR [17.17.17.17, 701]: Distributing disposition info to
all linecards
*May 27 23:56:04.699 UTC: AToM SMGR [17.17.17.17, 1201]: Sending Imposition update to slot
255
*May 27 23:56:04.699 UTC: AToM SMGR [17.17.17.17, 1201]: Imposition being done on ingress
interface
```

```
debug mpls l2transport ipc
```

```
*May 27 23:56:04.699 UTC: AToM SMGR [17.17.17.17, 1201]: Sending disposition update to  
slot 255  
*May 27 23:56:04.699 UTC: AToM SMGR [17.17.17.17, 1201]: Distributing disposition info to  
all linecards
```

debug mpls l2transport packet

To display information about the status of Any Transport over MPLS (AToM) switched packets, use the **debug mpls l2transport packet** command in privileged EXEC mode. To disable debugging output, use the **no** form of this command.

```
debug mpls l2transport packet {data | error}
```

```
no debug mpls l2transport packet {data | error}
```

Syntax Description

data	Displays (in hex) the AToM switched packets for imposition and disposition. This can help validate that packets are flowing between the CE routers. Also, you can display the packets to check the format of the data or the data itself.
error	Displays AToM switching errors, such as the reason that packets cannot be switched. This can help identify why data is not being transported.

Command Modes

Privileged EXEC

Command History

Release	Modification
12.0(23)S	This command was introduced.
12.2(14)S	This command was integrated into Cisco IOS Release 12.2(14)S.
12.2(15)T	This command was integrated into Cisco IOS Release 12.2(15)T.

Usage Guidelines

Use this command sparingly, because the command output can be overwhelming.

For platforms that support distributed switching, the command displays output only for packets switched by the central route processor module. Packets switched autonomously by the linecards are not displayed. For example, packets switched by Versatile Interface Processors (VIPs) on the Cisco 7500 router are not displayed.

Examples

The following is sample output from the **debug mpls l2transport packet** commands for a PPP over MPLS configuration:

```
Router# debug mpls l2transport packet data
AToM packet data debugging is on
```

```
Router# debug mpls l2transport packet error
AToM packet errors debugging is on
```

```
Router# show debug
AToM:
  AToM packet data debugging is on
  AToM packet errors debugging is on
```

```
*Mar 24 23:29:30.495: AToM-PPP Switching: check features failed.
```

```
*Mar 24 23:29:30.495: AToM-PPP Switching (Fast) Imposition Packet data: experimental bits are 0
```

debug mpls l2transport packet

```

*Mar 24 23:29:30.495: 0F 00 88 47 00 01 10 FF 00 01 51 02 00 00 00 00
*Mar 24 23:29:30.495: 00 FD C0 01 01 01 C0 4B 41 73 F4 00 01 00 02 CC
*Mar 24 23:29:30.495: 66 51 88 B4 CE 73 39 00 00 40 00 88 03 02 00 70
*Mar 24 23:29:30.495: 23 30 00 04 3C 61 83 C0 00 06 00 06 94 CC A7 23
*Mar 24 23:29:30.495: 49 84 D8 33 17 8C F2 60 00 11 9E 80 00 50 08 08
*Mar 24 23:29:30.495: 86 69 39 98 CD E2 02 49 B8 E9 9D 0D C6 53 A1 DC
*Mar 24 23:29:30.495: DE 72 35 88 09 E7 0C 60 61 3A 1A 4D C6 71 01 4C
*Mar 24 23:29:30.495: F2 73 CC 06 DC 38 6F 33 66 83 09 C8 CA 20 05 12
*Mar 24 23:29:30.495: 49 E5 31 00 A0 E8 6D 14 88 06 E3 21 80 C3 31 E4
*Mar 24 23:29:30.495: 28 21 E4 21 69 28 A6 2D 26 8A 45 82 02 B6 FC 39
*Mar 24 23:29:30.499: D8 60 A3 62 B1 60 A5 80
*Mar 24 23:29:31.835: ATOM-L2 Switching Disposition Packet data:
*Mar 24 23:29:31.835: FF 03 00 FD C0 04 8A 57 FF FF FF FF FF FF FF FF
*Mar 24 23:29:31.835: FF FF FB 14 B0 00

*Mar 24 23:29:49.423: ATOM-L2 Switching Disposition Packet data:
*Mar 24 23:29:49.423: FF 03 C0 21 01 11 00 0F 03 05 C2 23 05 05 06 5F
*Mar 24 23:29:49.423: 23 35 D4
*Mar 24 23:29:49.435: ATOM-PPP Switching: check features failed.
*Mar 24 23:29:49.435: ATOM-PPP Switching (Fast) Imposition Packet data: experimental bits
are 0
*Mar 24 23:29:49.435: 0F 00 88 47 00 01 10 FF 00 01 61 02 00 15 00 00
*Mar 24 23:29:49.435: C0 21 01 2F 00 0F 03 05 C2 23 05 05 06 5F CC 5F
*Mar 24 23:29:49.435: E5
*Mar 24 23:29:49.435: ATOM-PPP Switching: check features failed.
*Mar 24 23:29:49.435: ATOM-PPP Switching (Fast) Imposition Packet data: experimental bits
are 0
*Mar 24 23:29:49.435: 0F 00 88 47 00 01 10 FF 00 01 61 02 00 15 00 00
*Mar 24 23:29:49.435: C0 21 02 11 00 0F 03 05 C2 23 05 05 06 5F 23 35
*Mar 24 23:29:49.435: D4
*Mar 24 23:29:49.443: ATOM-L2 Switching Disposition Packet data:
*Mar 24 23:29:49.443: FF 03 C0 21 02 2F 00 0F 03 05 C2 23 05 05 06 5F
*Mar 24 23:29:49.443: CC 5F E5
*Mar 24 23:29:49.447: ATOM-L2 Switching Disposition Packet data:
*Mar 24 23:29:49.447: FF 03 C2 23 01 D0 00 1C 10 45 59 13 1A 92 FD 93
*Mar 24 23:29:49.447: 01 A2 CF B6 FB 3A 04 46 93 63 65 32 2D 67 73 72
*Mar 24 23:29:49.451: ATOM-PPP Switching: check features failed.
*Mar 24 23:29:49.451: ATOM-PPP Switching (Fast) Imposition Packet data: experimental bits
are 0
*Mar 24 23:29:49.451: 0F 00 88 47 00 01 10 FF 00 01 61 02 00 22 00 00
*Mar 24 23:29:49.451: C2 23 01 F5 00 1C 10 F1 98 35 3F 79 F2 1A 15 10
*Mar 24 23:29:49.451: B4 C0 73 D7 B1 9F 2A 63 65 31 2D 67 73 72
*Mar 24 23:29:49.455: ATOM-PPP Switching: check features failed.
*Mar 24 23:29:49.455: ATOM-PPP Switching (Fast) Imposition Packet data: experimental bits
are 0
*Mar 24 23:29:49.455: 0F 00 88 47 00 01 10 FF 00 01 61 02 00 22 00 00
*Mar 24 23:29:49.455: C2 23 02 D0 00 1C 10 56 4A 32 5B 99 55 D5 CF 44
*Mar 24 23:29:49.455: FC D3 D9 3F CC 8C A8 63 65 31 2D 67 73 72
*Mar 24 23:29:49.463: ATOM-L2 Switching Disposition Packet data:
*Mar 24 23:29:49.463: FF 03 C2 23 02 F5 00 1C 10 45 84 E4 E5 DD C0 5F
*Mar 24 23:29:49.463: FD 2F 37 63 9A 3D 03 7B B9 63 65 32 2D 67 73 72
*Mar 24 23:29:49.463: ATOM-L2 Switching Disposition Packet data:
*Mar 24 23:29:49.463: FF 03 C2 23 03 D0 00 04
*Mar 24 23:29:49.471: ATOM-PPP Switching: check features failed.
*Mar 24 23:29:49.471: ATOM-PPP Switching (Fast) Imposition Packet data: experimental bits
are 0
*Mar 24 23:29:49.471: 0F 00 88 47 00 01 10 FF 00 01 61 02 00 0A 00 00
*Mar 24 23:29:49.471: C2 23 03 F5 00 04
*Mar 24 23:29:49.471: ATOM-PPP Switching: check features failed.
*Mar 24 23:29:49.471: ATOM-PPP Switching (Fast) Imposition Packet data: experimental bits
are 0
*Mar 24 23:29:49.471: 0F 00 88 47 00 01 10 FF 00 01 61 02 00 10 00 00
*Mar 24 23:29:49.471: 80 21 01 0B 00 0A 03 06 78 01 01 78
*Mar 24 23:29:49.475: ATOM-PPP Switching: check features failed.

```

debug mpls l2transport signaling

To display information about the Any Transport over MPLS (AToM) signaling protocol, use the **debug mpls l2transport signaling** command in privileged EXEC mode. To disable debugging output, use the **no** form of this command.

```
debug mpls l2transport signaling {event | message}
```

```
no debug mpls l2transport signaling {event | message}
```

Syntax Description

event	Displays AToM signaling events.
message	Displays AToM signaling status messages.

Command Modes

Privileged EXEC

Command History

Release	Modification
12.0(23)S	This command was introduced.
12.2(14)S	This command was integrated into Cisco IOS Release 12.2(14)S.
12.2(15)T	This command was integrated into Cisco IOS Release 12.2(15)T.

Examples

The following is sample output from the **debug mpls l2transport signaling** command:

```
Router# debug mpls l2transport signaling event
AToM LDP event debugging is on

Router# debug mpls l2transport signaling message
AToM LDP message debugging is on

Router# show debugging
AToM:
  AToM LDP event debugging is on
  AToM LDP message debugging is on

*Mar 24 23:10:55.611: AToM LDP [9.9.9.9]: Allocate LDP instance
*Mar 24 23:10:55.611: AToM LDP [9.9.9.9]: Opening session, 1 clients
*Mar 24 23:10:56.063: %SYS-5-CONFIG_I: Configured from console by console
*Mar 24 23:10:56.583: %LINEPROTO-5-UPDOWN: Line protocol on Interface Serial3/0, changed
state to up
*Mar 24 23:11:00.539: AToM LDP [9.9.9.9]: Session is up
*Mar 24 23:11:00.539: AToM LDP [9.9.9.9]: Peer address change, add 1.1.1.100
*Mar 24 23:11:00.539: AToM LDP [9.9.9.9]: Peer address change, add 46.1.1.6
*Mar 24 23:11:00.539: AToM LDP [9.9.9.9]: Peer address change, add 9.9.9.9
*Mar 24 23:11:00.539: AToM LDP [9.9.9.9]: Peer address change, add 57.1.1.6
*Mar 24 23:11:00.539: AToM LDP [9.9.9.9]: Sending label mapping msg
vc type 7, cbit 1, vc id 50, group id 6, vc label 21, status 0, mtu 1500
*Mar 24 23:11:00.539: AToM LDP [9.9.9.9]: Received label mapping msg, id 113
vc type 7, cbit 1, vc id 50, group id 6, vc label 21, status 0, mtu 1500
```

debug mpls l2transport vc

To display information about the status of the AToM VCs, use the **debug mpls l2transport vc** command in privileged EXEC mode. To disable debugging output, use the **no** form of this command.

```
debug mpls l2transport vc {event | fsm}
```

```
no debug mpls l2transport vc {event | fsm}
```

Syntax Description	event	Displays AToM event messages about the VCs.
	fsm	Displays the finite state machine.

Command Modes	Privileged EXEC
---------------	-----------------

Command History	Release	Modification
	12.0(23)S	This command was introduced.
	12.2(14)S	This command was integrated into Cisco IOS Release 12.2(14)S.
	12.2(15)T	This command was integrated into Cisco IOS Release 12.2(15)T.

Usage Guidelines	You can issue this command from the line card or route processor.
------------------	---

Examples	The following is sample output from the debug mpls l2transport vc commands:
----------	--

```
Router# debug mpls l2transport vc event
AToM vc event debugging is on

Router# debug mpls l2transport vc fsm
AToM vc fsm debugging is on

Router# show debugging
AToM:
  AToM vc event debugging is on
  AToM vc fsm debugging is on

*Mar 24 23:17:24.371: AToM MGR [9.9.9.9, 50]: Event provision, state changed from idle to
provisioned
*Mar 24 23:17:24.371: AToM MGR [9.9.9.9, 50]: Provision vc
*Mar 24 23:17:24.371: AToM SMGR [9.9.9.9, 50]: Requesting VC create, vc_handle 61A09930
*Mar 24 23:17:24.371: AToM MGR [9.9.9.9, 50]: Event local up, state changed from
provisioned to local standby
*Mar 24 23:17:24.371: AToM MGR [9.9.9.9, 50]: Update local vc label binding
*Mar 24 23:17:24.371: AToM SMGR [9.9.9.9, 50]: successfully processed create request
*Mar 24 23:17:24.875: %SYS-5-CONFIG_I: Configured from console by console
*Mar 24 23:17:25.131: %LINEPROTO-5-UPDOWN: Line protocol on Interface Serial3/0, changed
state to up

*Mar 24 23:17:28.567: AToM MGR [9.9.9.9, 50]: Event ldp up, state changed from local
standby to local ready
*Mar 24 23:17:28.567: AToM MGR [9.9.9.9, 50]: Advertise local vc label binding
```

```
*Mar 24 23:17:28.567: AToM MGR [9.9.9.9, 50]: Event remote up, state changed from local
ready to establishing
*Mar 24 23:17:28.567: AToM MGR [9.9.9.9, 50]: Remote end up
*Mar 24 23:17:28.567: AToM MGR [9.9.9.9, 50]: Event remote validated, state changed from
establishing to established
*Mar 24 23:17:28.567: AToM MGR [9.9.9.9, 50]: Validate vc, activating data plane
*Mar 24 23:17:28.567: AToM SMGR [9.9.9.9, 50]: Processing imposition update, vc_handle
61A09930, update_action 3, remote_vc_label 21
*Mar 24 23:17:28.567: AToM SMGR [9.9.9.9, 50]: Imposition Programmed, Output Interface:
PO5/0
*Mar 24 23:17:28.567: AToM SMGR [9.9.9.9, 50]: Processing disposition update, vc_handle
61A09930, update_action 3, local_vc_label 22
*Mar 24 23:17:28.571: AToM SMGR: Processing TFIB event for 9.9.9.9
*Mar 24 23:17:28.571: AToM SMGR [9.9.9.9, 50]: Imposition Programmed, Output Interface:
PO5/0
```

encapsulation (Any Transport over MPLS)

To configure the ATM adaptation layer (AAL) for an Any Transport over MPLS (AToM) ATM permanent virtual circuit (PVC), use the **encapsulation** command in AToM-VC configuration mode. To remove an encapsulation from an AToM PVC, use the no form of this command.

encapsulation *layer-type*

no encapsulation *layer-type*

Syntax Description

<i>layer-type</i>	The adaptation layer type. Possible values are: aal5 —ATM adaptation layer 5 aal0 —ATM adaptation layer 0
-------------------	---

Defaults

The default encapsulation is AAL5.

Command Modes

AToM VC configuration

Command History

Release	Modification
12.0(23)S	This command was introduced.
12.2(14)S	This command was integrated into Cisco IOS Release 12.2(14)S.
12.2(15)T	This command was integrated into Cisco IOS Release 12.2(15)T.

Usage Guidelines

The **pvc** command and the **encapsulation** command work together. How you use the commands for AToM is slightly different than for all other applications. The following table shows the differences in how the commands are used:

Other Applications	AToM
<code>pvc 1/100 encapsulation aal5snap</code>	<code>pvc 1/100 l2transport encapsulation aal5</code>

The following list highlights the differences:

- **pvc** command: For most applications, you create a PVC by using the **pvc vpi/vci** command. For AToM, you must add the **l2transport** keyword to the **pvc** command. The **l2transport** keyword enables the PVC to transport Layer 2 packets.
- **encapsulation** command: The **encapsulation** command for AToM has only two keyword values: **aal5** or **aal0**. You cannot specify an encapsulation type. In contrast, the **encapsulation aal5** command you use for most other applications requires you to specify the encapsulation type, such as **aal5snap**.
- **pvc** command and **encapsulation** command: The AToM **encapsulation** command works only with the **pvc** command. You cannot create switched virtual circuits or VC bundles to transport Layer 2 packets. You can only use PVCs to transport Layer 2 packets.

When you use the **aal5** keyword, incoming cells (except OAM cells) on that PVC are treated as AAL5 encapsulated packets. The router reassembles the packet from the incoming cells. The router does not check the contents of the packet, so it does not need to know the encapsulation type (such as aal5snap, aal5mux, and so on). After imposing the MPLS label stack, the router sends the reassembled packet over the MPLS core network.

When you use the **aal0** keyword, the router strips the header error control (HEC) byte from the cell header and adds the MPLS label stack. The router sends the cell over the MPLS core network.

Examples

The following example shows how to configure a PVC to transport AAL5 packets for AToM:

```
pvc 1/100 12transport
  encapsulation aal0
```

Related Commands

Command	Description
pvc	Creates or assigns a name to an ATM PVC.

mpls l2transport route

To enable routing of Any Transport over MPLS (AToM) packets over a specified virtual circuit (VC), use the **mpls l2transport route** command in the appropriate command mode. To delete the VC, use the **no** form of this command on both routers.

mpls l2transport route *destination vc-id*

no mpls l2transport route *destination vc-id*

Syntax Description

<i>destination</i>	Specifies the Label Distribution Protocol (LDP) IP address of the remote provider edge (PE) router.
<i>vc-id</i>	Assigns a VC ID to the virtual circuit between two PE routers.

Defaults

No default behavior or values.

Command Modes

Depending on the AToM transport type you are configuring, you use the **mpls l2transport route** command in one of the following command modes:

Transport Type	Command Mode
ATM AAL5 and Cell Relay	ATM VC configuration mode
Ethernet VLAN	Subinterface configuration mode
Frame Relay	Connect submode
HDLC and PPP	Interface configuration mode

Command History

Release	Modification
12.1(8a)E	This command was introduced.
12.0(21)ST	This command was integrated into Cisco IOS Release 12.0(21)ST.
12.0(23)S	This command was integrated into Cisco IOS Release 12.0(23)S.
12.2(14)S	This command was integrated into Cisco IOS Release 12.2(14)S.
12.2(15)T	This command was integrated into Cisco IOS Release 12.2(15)T.

Usage Guidelines

An MPLS VC runs across an MPLS cloud to connect interfaces on two provider edge (PE) routers.

Use this command on each PE router to route packets across the MPLS cloud to the interface of the other PE router. Specify the LDP IP address of the other PE router for the *destination* parameter. Do not specify the IP address of the router from which you are issuing the command.

You can choose any number for the VC ID. However, the VC ID must be unique per pair of routers. Therefore, in large networks, it may be necessary to track the VC ID assignments to ensure that a VC ID does not get assigned twice.

Examples

The following examples show some implementations of the command. Two routers are named PE1 and PE2, which establish a VC to transport packets. PE1 has IP address 192.168.0.1, and PE2 has IP address 192.168.0.1. The VC ID is 50.

ATM AAL5 over MPLS Example

At PE1, you issue the following commands:

```
PE1_Router(config)# interface atm5/0.100
PE1_Router(config-if)# pvc 1/200
PE1_Router(config-atm-vc)# encapsulation aal5
PE1_Router(config-atm-vc)# mpls l2transport route 192.168.0.1 50
```

At PE2, you issue the following commands:

```
PE2_Router(config)# interface atm5/0.100
PE2_Router(config-if)# pvc 1/200
PE2_Router(config-atm-vc)# encapsulation aal5
PE2_router(config-atm-vc)# mpls l2transport route 172.16.0.1 50
```

ATM Cell Relay over MPLS Example

At PE1, you issue the following commands:

```
PE1_Router(config)# interface atm5/0.100
PE1_Router(config-if)# pvc 1/200 l2transport
PE1_Router(config-atm-vc)# encapsulation aal0
PE1_Router(config-atm-vc)# mpls l2transport route 192.168.0.1 50
```

At PE2, you issue the following commands:

```
PE2_Router(config)# interface atm5/0.100
PE2_Router(config-if)# pvc 1/200 l2transport
PE2_Router(config-atm-vc)# encapsulation aal0
PE2_router(config-atm-vc)# mpls l2transport route 172.16.0.1 50
```

Ethernet over MPLS Example

At PE1, you issue the following commands:

```
PE1_router(config)# interface GigabitEthernet1/0.2
PE1_Router(config-subif)# encapsulation dot1Q 200
PE1_Router(config-subif)# mpls l2transport route 192.168.0.1 50
```

At PE2, you issue the following commands:

```
PE2_router(config)# interface GigabitEthernet2/0.1
PE2_Router(config-subif)# encapsulation dot1Q 200
PE2_Router(config-subif)# mpls l2transport route 172.16.0.1 50
```

Frame Relay over MPLS Example

At PE1, you issue the following commands:

```
PE1_router(config)# connect frompls1 Serial5/0 1000 l2transport
PE1_router(config-fr-pw-switching)# mpls l2transport route 192.168.0.1 50
```

At PE2, you issue the following commands:

```
PE2_router(config)# connect frompls2 Serial2/0 102 l2transport
PE2_router(config-fr-pw-switching)# mpls l2transport route 172.16.0.1 50
```

HDLC over MPLS Example

At PE1, you issue the following commands:

```
PE1_router(config)# interface Serial13/0
```

```
PE1_router(config-if)# encapsulation hdlc  
PE1_router(config-if)# mpls l2transport route 192.168.0.1 50
```

At PE2, you issue the following commands:

```
PE2_router(config)# interface Serial1/0  
PE2_router(config-if)# encapsulation hdlc  
PE2_router(config-if)# mpls l2transport route 172.16.0.1 50
```

PPP over MPLS Example

At PE1, you issue the following commands:

```
PE1_router(config)# interface Serial3/0  
PE1_router(config-if)# encapsulation ppp  
PE1_router(config-if)# mpls l2transport route 192.168.0.1 50
```

At PE2, you issue the following commands:

```
PE2_router(config)# interface Serial1/0  
PE2_router(config-if)# encapsulation ppp  
PE2_router(config-if)# mpls l2transport route 172.16.0.1 50
```

oam-ac emulation-enable

To enable Operation, Administration, and Maintenance (OAM) cell emulation on ATM adaptation layer 5 (AAL5) over Multiprotocol Label Switching (MPLS), use the **oam-ac emulation-enable** command in the ATM VC configuration mode on both provider edge (PE) routers. To disable OAM cell emulation, use the **no** form of this command on both routers.

oam-ac emulation-enable [*ais-rate*]

no oam-ac emulation-enable [*ais-rate*]

Syntax Description	<i>ais-rate</i>	(Optional) The rate (in seconds) at which the AIS cells should be sent. The range is 0 - 60 seconds. If you specify 0, no AIS cells are sent. The default is 1 second, which means that one AIS cell is sent every second.
---------------------------	-----------------	--

Defaults	By default OAM cell emulation is disabled. If you enable OAM cell emulation without specifying an AIS rate, the default is to send one AIS cell every second.
-----------------	---

Command Modes	ATM VC configuration mode
----------------------	---------------------------

Command History	Release	Modification
	12.0(23)S	This command was introduced.
	12.2(14)S	This command was integrated into Cisco IOS Release 12.2(14)S.
	12.2(15)T	This command was integrated into Cisco IOS Release 12.2(15)T.

Usage Guidelines	This command is only applicable to AAL5 over MPLS and is not supported with ATM Cell Relay over MPLS.
-------------------------	---

This command is only available when you specify the **pvc vpi/vci l2transport** command.

Examples	The following example shows how to enable OAM cell emulation on an ATM PVC.
-----------------	---

```
Router# interface ATM 1/0/0
Router(config-if)# pvc 1/200 l2transport
Router(config-atm-vc)# oam-ac emulation-enable
```

The following example sets the rate at which an AIS cell is sent to every 30 seconds:

```
Router (config-atm-vc)# oam-ac emulation-enable 30
```

Related Commands	Command	Description
	show atm pvc	Displays all ATM PVCs and traffic information.

pvc

To create or assign a name to an ATM permanent virtual circuit (PVC), to specify the encapsulation type on an ATM PVC, and to enter interface-ATM-VC configuration mode, use the **pvc** command in interface or subinterface configuration mode. To remove an ATM PVC, use the **no** form of this command.

```
pvc [name] vpi/vci [ces | ilmi | qsaal | smds | l2transport]
```

```
no pvc [name] vpi/vci [ces | ilmi | qsaal | smds | l2transport]
```

Syntax Description

<i>name</i>	(Optional) The name of the PVC or map. The name can be up to 16 characters long.
<i>vpi</i>	ATM network virtual path identifier (VPI) for this PVC. The absence of the slash (/) and a <i>vpi</i> value defaults the <i>vpi</i> value to 0.
<p>Value Ranges</p> <ul style="list-style-type: none"> • Cisco 7200 and 7500 series routers: 0 to 255 • Cisco 4500 and 4700 routers: 0 to 1 less than the quotient of 8192 divided by the value set by the atm vc-per-vc command • Cisco 2600 and 3600 series routers using Inverse Multiplexing for ATM (IMA): 0 to 15, 64 to 79, 128 to 143, and 192 to 207 <p>The arguments <i>vpi</i> and <i>vci</i> cannot both be set to 0; if one is 0, the other cannot be 0.</p>	
<i>vci</i>	<p>ATM network virtual channel identifier (VCI) for this PVC. This value ranges from 0 to 1 less than the maximum value set for this interface by the atm vc-per-vc command. Typically, lower values 0 to 31 are reserved for specific traffic (for example, F4 OAM, SVC signaling, ILMI, and so on) and should not be used.</p> <p>The VCI is a 16-bit field in the header of the ATM cell. The VCI value is unique only on a single link, not throughout the ATM network, because it has local significance only.</p> <p>The arguments <i>vpi</i> and <i>vci</i> cannot both be set to 0; if one is 0, the other cannot be 0.</p>
ces	(Optional) Circuit Emulation Service encapsulation. This keyword is available on the OC-3/STM-1 ATM Circuit Emulation Service network module only.
ilmi	(Optional) Sets up communication with the Interim Local Management Interface (ILMI); the associated <i>vpi</i> and <i>vci</i> values ordinarily are 0 and 16, respectively.
qsaal	(Optional) A signaling-type PVC used for setting up or tearing down SVCs; the associated <i>vpi</i> and <i>vci</i> values ordinarily are 0 and 5, respectively.
smds	(Optional) Encapsulation for SMDS networks. If you are configuring an ATM PVC on the ATM Interface Processor (AIP), you must configure AAL3/4SMDS using the atm aal aal3/4 command before specifying smds encapsulation. If you are configuring an ATM network processor module (NPM), the atm aal aal3/4 command is not required. SMDS encapsulation is not supported on the ATM port adapter.
l2transport	(Optional) Used to specify that the PVC is switched and not terminated.

Defaults

No PVC is defined. When a PVC is defined, the global default of the **encapsulation** command applies (*aal-encap* = **aal5snap**).

Command Modes Interface or subinterface configuration

Command History	Release	Modification
	11.3 T	This command was introduced.
	12.1(2)T	The following modifications were made: <ul style="list-style-type: none"> • The ranges for the VPI were increased for Cisco 2600 and Cisco 3600 series routers using IMA. • The ces keyword was added for configuring CES encapsulation when using the OC-3/STM-1 ATM Circuit Emulation Service network module on Cisco 2600 and Cisco 3600 series routers.
	12.0(23)S	The l2transport keyword was added.
	12.2(14)S	This command was integrated into Cisco IOS Release 12.2(14)S.
	12.2(15)T	This command was integrated into Cisco IOS Release 12.2(15)T.

Usage Guidelines

Creating and Configuring PVCs

The **pvc** command replaces the **atm pvc** command, which, although still supported and available, will become obsolete in the near future. Use the **pvc** command to configure a single ATM VC only, not a VC that is a bundle member. We recommend that you use the **pvc** command in conjunction with the **encapsulation** and **random-detect attach** commands instead of the **atm pvc** command.

The **pvc** command creates a PVC and attaches it to the VPI and VCI specified. Both the *vpi* and *vci* arguments cannot be simultaneously specified as 0; if one is 0, the other cannot be 0.

When configuring an SVC, use the **pvc** command to configure the PVC that handles SVC call setup and termination. In this case, specify the **qsaal** keyword. See the “Examples” section.

ATM PVC Names

Once you specify a *name* for a PVC, you can reenter interface-ATM-VC configuration mode by simply entering the **pvc name** command. You can remove a PVC and any associated parameters by entering **no pvc name** or **no pvc vpi/vci**.



Note

After configuring the parameters for an ATM PVC, you must exit the interface-ATM-VC configuration mode in order to create the PVC and enable the settings.

Encapsulation Types on ATM PVCs

Specify CES, ILMI, QSAAL, or SMDS as the encapsulation type on an ATM PVC. (To configure other encapsulation types, see the **encapsulation** command.)

Configuring CES encapsulation on a PVC is equivalent to creating a constant bit rate (CBR) class of service.

Rate Queues

The Cisco IOS software dynamically creates rate queues as necessary to satisfy the requests of the **pvc** commands.

Default Configurations

If **ilmi**, **qsaal**, or **smds** encapsulation is not explicitly configured on the ATM PVC, the PVC inherits the following default configuration (listed in order of precedence):

- Configuration of the **encapsulation** command in a VC class assigned to the PVC itself.
- Configuration of the **encapsulation** command in a VC class assigned to the ATM subinterface of the PVC.
- Configuration of the **encapsulation** command in a VC class assigned to the ATM main interface of the PVC.
- Global default: The global default of the **encapsulation** command applies (*aal-encap* = **aal5snap**).

Examples

The following example creates a PVC with VPI 0 and VCI 16, and communication is set up with the ILMI:

```
pvc cisco 0/16 ilmi
exit
```

The following example creates a PVC used for ATM signaling for an SVC. It specifies VPI 0 and VCI 5:

```
pvc cisco 0/5 qsaal
exit
```

The following example configures the PVC called “cisco” to use class-based weighted fair queueing (CBWFQ). It attaches a policy map called “policy1” to the PVC. The classes the make up “policy1” determine the service policy for the PVC:

```
pvc cisco 0/5
 service-policy output policy1
 vbr-nrt 2000 2000
 encaps aal5snap
```

Related Commands

Command	Description
atm vc-per-vp	Sets the maximum number of VCIs to support per VPI.
pvc-bundle	Adds a PVC to a bundle as a member of the bundle and enters bundle-vc configuration mode in order to configure that PVC bundle member.

show atm pvc

To display all ATM permanent virtual connections (PVCs) and traffic information, use the **show atm pvc** command in privileged EXEC mode.

```
show atm pvc [vpi/vci | name | interface atm interface-number] [ppp]
```

Syntax Description

<i>vpi/vci</i>	(Optional) The ATM virtual path identifier (VPI) and virtual channel identifier (VCI) numbers. The absence of the slash (/) and a <i>vpi</i> value defaults the <i>vpi</i> value to 0.
<i>name</i>	(Optional) Name of the PVC.
interface atm <i>interface-number</i>	(Optional) Interface number or subinterface number of the PVC. Displays all PVCs on the specified interface or subinterface. The <i>interface-number</i> argument uses one of the following formats, depending on which router platform you are using: <ul style="list-style-type: none"> For the ATM Interface Processor (AIP) on Cisco 7500 series routers; for the ATM port adapter, ATM-CES port adapter, and enhanced ATM port adapter on Cisco 7200 series routers; for the 1-port ATM-25 network module on Cisco 2600 and 3600 series routers: <i>slot/0</i>[<i>.subinterface-number</i> multipoint] For the ATM port adapter and enhanced ATM port adapter on Cisco 7500 series routers: <i>slot/port-adapter/0</i>[<i>.subinterface-number</i> multipoint] For the NPM on Cisco 4500 and 4700 routers: <i>number</i>[<i>.subinterface-number</i> multipoint] For a description of these arguments, refer to the interface atm command.
ppp	(Optional) Displays each PVC configured for PPP over ATM.

Command Modes

Privileged EXEC

Command History

Release	Modification
11.3T	This command was introduced.
12.1(1)T	This command was modified to display PPPoE status.
12.0(23)S	This command was modified to display OAM cell emulation status for Any Transport over MPLS (AToM).
12.2(14)S	This command was integrated into Cisco IOS Release 12.2(14)S.
12.2(15)T	This command was integrated into Cisco IOS Release 12.2(15)T.

Usage Guidelines

If the *vpi/vci* or *name* argument is not specified, the output of this command is the same as that of the **show atm vc** command, but only the configured PVCs are displayed. See the first sample output in the “Examples” section.

If the *vpi/vci* or *name* argument is specified, the output of this command is the same as the **show atm vc vcd** command, with extra information related to PVC management including connection name, detailed states, and Operation, Administration, and Maintenance (OAM) counters. See the second and third sample output in the “Examples” section.

If the **interface atm interface-number** option is included in the command, all PVCs under that interface or subinterface are displayed. See the third sample output in the “Examples” section.

Examples

The following is sample output from the **show atm pvc** command:

```
Router# show atm pvc
```

Interface	VCD/ Name	VPI	VCI	Type	Encaps	Peak Kbps	Avg/Min Kbps	Burst Cells	Sts
2/0	1	0	5	PVC	SAAL	155000	155000		UP
2/0	2	0	16	PVC	ILMI	155000	155000		UP
2/0.2	101	0	50	PVC	SNAP	155000	155000		UP
2/0.2	102	0	60	PVC	SNAP	155000	155000		DOWN
2/0.2	104	0	80	PVC	SNAP	155000	155000		UP
2/0	hello	0	99	PVC	SNAP	1000			UP

The following is sample output from the **show atm pvc** command with the *vpi/vci* argument specified:

```
Router# show atm pvc 0/41
```

```
ATM2/0: VCD: 3, VPI: 0, VCI: 41
UBR, PeakRate: 155000
AAL5-LLC/SNAP, etype:0x0, Flags: 0xC20, VMode: 0x0
OAM frequency: 0 second(s), OAM retry frequency: 1 second(s), OAM retry frequency: 1
second(s)
OAM up retry count: 3, OAM down retry count: 5
OAM Loopback status: OAM Disabled
OAM VC state: Not Managed
ILMI VC state: Not Managed
InARP frequency: 15 minutes(s)
InPkts: 31759, OutPkts: 26497, InBytes: 2356434, OutBytes: 1589743
InPRoc: 15785, OutPRoc: 26472, Broadcasts: 0
InFast: 20, OutFast: 20, InAS: 15954, OutAS: 6
OAM cells received: 0
F5 InEndloop: 0, F5 InSegloop: 0, F5 InAIS: 0, F5 InRDI: 0
F4 InEndloop: 0, F4 InSegloop: 0, F4 InAIS: 0, F4 InRDI: 0
OAM cells sent: 0
F5 OutEndloop: 0, F5 OutSegloop: 0, F5 OutRDI: 0
F4 OutEndloop: 0, F4 OutSegloop: 0, F4 OutRDI: 0
OAM cell drops: 0
Status: UP
PPPOE enabled.
```

The following sample output from the **show atm pvc** command displays OAM cell emulation statistics, which are marked by exclamation points:

```
router# show atm pvc 5/500
```

```
ATM4/1/0.200: VCD: 6, VPI: 5, VCI: 500
UBR, PeakRate: 1
AAL5-LLC/SNAP, etype:0x0, Flags: 0x34000C20, VMode: 0x0
OAM Cell Emulation: enabled, F5 End2end AIS Xmit frequency: 1 second(s) !!!
OAM frequency: 0 second(s), OAM retry frequency: 1 second(s)
OAM up retry count: 3, OAM down retry count: 5
OAM Loopback status: OAM Disabled
OAM VC state: Not ManagedVerified
ILMI VC state: Not Managed
```

```

InPkts: 564, OutPkts: 560, InBytes: 19792, OutBytes: 19680
InPRoc: 0, OutPRoc: 0
InFast: 4, OutFast: 0, InAS: 560, OutAS: 560
InPktDrops: 0, OutPktDrops: 0
CrcErrors: 0, SarTimeOuts: 0, OverSizedSDUs: 0
Out CLP=1 Pkts: 0
OAM cells received: 26
F5 InEndloop: 0, F5 InSegloop: 0, F5 InAIS: 0, F5 InRDI: 26
OAM cells sent: 77
F5 OutEndloop: 0, F5 OutSegloop: 0, F5 OutAIS: 77, F5 OutRDI: 0 !!!
OAM cell drops: 0
Status: UP

```

The following is sample output from the **show atm pvc** command with the ATM subinterface specified:

```
Router# show atm pvc interface atm 2/0.2
```

Interface	VCD/ Name	VPI	VCI	Type	Encaps	Peak Kbps	Avg/Min Kbps	Burst Cells	Sts
2/0.2	101	0	50	PVC	SNAP	155000	155000		UP
2/0.2	102	0	60	PVC	SNAP	155000	155000		DOWN
2/0.2	104	0	80	PVC	SNAP	155000	155000		UP

Table 13 describes significant fields shown in the displays.

Table 13 show atm pvc Field Descriptions

Field	Description
Interface	Interface and subinterface slot and port.
VCD/Name	Virtual connection descriptor (virtual connection number). The connection name is displayed if a name for the VC was configured using the pvc command.
VPI	Virtual path identifier.
VCI	Virtual channel identifier.
Type	Type of PVC detected from PVC discovery, either PVC-D, PVC-L, or PVC-M: <ul style="list-style-type: none"> PVC-D indicates a PVC created due to PVC discovery. PVC-L indicates that the corresponding peer of this PVC could not be found on the switch. PVC-M indicates that some or all of the QoS parameters of this PVC mismatch that of the corresponding peer on the switch.
Encaps	Type of ATM adaptation layer (AAL) and encapsulation.
Peak or PeakRate	Kilobits per second sent at the peak rate.
Avg/Min or Average Rate	Kilobits per second sent at the average rate.
Burst Cells	Value that equals the maximum number of ATM cells the VC can send at peak rate.
Sts or Status	Status of the VC connection: <ul style="list-style-type: none"> UP indicates that the connection is enabled for data traffic. DOWN indicates that the connection is not ready for data traffic. When the Status field is DOWN, a State field is shown. See a description of the different values for this field listed later in this table. INACTIVE indicates that the interface is down.

Table 13 show atm pvc Field Descriptions (continued)

Field	Description
Connection Name	The name of the PVC.
UBR, UBR+, or VBR-NRT	<ul style="list-style-type: none"> • UBR—Unspecified bit rate QoS is specified for this PVC. See the ubr command for further information. • UBR+—Unspecified bit rate QoS is specified for this PVC. See the ubr+ command for further information. • VBR-NRT—Variable bit rate—Non real-time QoS rates are specified for this PVC. See the vbr-nrt command for further information.
etype	Encapsulation type.
Flags	<p>Bit mask describing VC information. The flag values are summed to result in the displayed value:</p> <ul style="list-style-type: none"> • 0x20—PVC • 0x40—SVC • 0x0—AAL5-SNAP • 0x1—AAL5-NLPID • 0x2—AAL5-FRNLPID • 0x3—AAL5-MUX • 0x4—AAL3/4-SMDS • 0x5—QSAAL • 0x6—ILMI • 0x7—AAL5-LANE • 0x9—AAL5-CISCOPPP • 0x10—ACTIVE
virtual-access	Virtual access interface identifier.
virtual-template	Virtual template identifier.
VCmode	AIP-specific or NPM-specific register describing the usage of the VC. This register contains values such as rate queue, peak rate, and AAL mode, which are also displayed in other fields.
OAM Cell emulation	The status of the OAM cell emulation functionality. It is either enabled or disabled.
F5 end2end AIS xmit frequency	Number of seconds between sending AIS cells.
OAM frequency	Number of seconds between sending OAM loopback cells.
OAM retry frequency	The frequency (in seconds) that end-to-end F5 loopback cells should be sent when a change in up/down state is being verified. For example, if a PVC is up and a loopback cell response is not received after the value of the <i>frequency</i> argument (in seconds) specified using the oam-pvc command, then loopback cells are sent at the value of the <i>retry-frequency</i> argument to verify whether the PVC is down.
OAM up retry count	Number of consecutive end-to-end F5 OAM loopback cell responses that must be received in order to change a PVC state to up. Does not apply to SVCs.
OAM down retry count	Number of consecutive end-to-end F5 OAM loopback cell responses that are not received in order to change a PVC state to down or tear down an SVC.

Table 13 *show atm pvc Field Descriptions (continued)*

Field	Description
OAM Loopback status	Status of end-to-end F5 OAM loopback cell generation for this VC. This field will have one of the following values: <ul style="list-style-type: none"> • OAM Disabled—End-to-end F5 OAM loopback cell generation is disabled. • OAM Sent—OAM cell was sent. • OAM Received—OAM cell was received. • OAM Failed—OAM reply was not received within the frequency period or contained bad correlation tag.ssss.
OAM VC state	This field will have one of the following states for this VC: <ul style="list-style-type: none"> • AIS/RDI—The VC received AIS/RDI cells. End-to-end F5 OAM loopback cells are not sent in this state. • AIS Out — The VC is sending out AIS cells. OAM loopback cells and replies are not sent in this state. Incoming AIS cells are replied with RDI cells, but the state does not change. • Down Retry—An OAM loopback failed. End-to-end F5 OAM loopback cells are sent at retry frequency to verify that the VC is really down. After down-count unsuccessful retries, the VC goes to the Not Verified state. • Not Managed—VC is not being managed by OAM. • Not Verified—VC has not been verified by end-to-end F5 OAM loopback cells. AIS and RDI conditions are cleared. • Up Retry—An OAM loopback was successful. End-to-end F5 OAM loopback cells are sent at retry frequency to verify the VC is really up. After up-count successive and successful loopback retries, the VC goes to the Verified state. • Verified—Loopbacks are successful. AIS/RDI cell was not received.
ILMI VC state	This field will have one of the following states for this VC: <ul style="list-style-type: none"> • Not Managed—VC is not being managed by ILMI. • Not Verified—VC has not been verified by ILMI. • Verified—VC has been verified by ILMI.
VC is managed by OAM/ILMI	VC is managed by OAM or ILMI.
InARP frequency	Number of minutes for the Inverse Address Resolution Protocol (IARP) time period.
InPkts	Total number of packets received on this VC. This number includes all fast-switched and process-switched packets.
OutPkts	Total number of packets sent on this VC. This number includes all fast-switched and process-switched packets.
InBytes	Total number of bytes received on this VC. This number includes all fast-switched and process-switched bytes.
OutBytes	Total number of bytes sent on this VC. This number includes all fast-switched and process-switched bytes.
InPRoc	Number of process-switched input packets.
OutPRoc	Number of process-switched output packets.

Table 13 show atm pvc Field Descriptions (continued)

Field	Description
Broadcasts	Number of process-switched broadcast packets.
InFast	Number of fast-switched input packets.
OutFast	Number of fast-switched output packets.
InAS	Number of autonomous-switched or silicon-switched input packets.
OutAS	Number of autonomous-switched or silicon-switched output packets.
OAM cells received	Total number of OAM cells received on this VC.
F5 InEndloop	Number of end-to-end F5 OAM loopback cells received.
F5 InSegloop	Number of segment F5 OAM loopback cells received.
F5 InAIS	Number of F5 OAM AIS cells received.
F5 InRDI	Number of F5 OAM RDI cells received.
F4 InEndloop	Number of end-to-end F4 OAM loopback cells received.
F4 InSegloop	Number of segment F4 OAM loopback cells received.
F4 InAIS	Number of F4 OAM AIS cells received.
F4 InRDI	Number of F4 OAM RDI cells received.
OAM cells sent	Total number of OAM cells sent on this VC.
F5 OutEndloop	Number of end-to-end F5 OAM loopback cells sent.
F5 OutSegloop	Number of segment F5 OAM loopback cells sent.
F5 OutAIS	Number of F5 OAM AIS cells sent
F5 OutRDI	Number of F5 OAM RDI cells sent.
OAM cell drops	Number of OAM cells dropped (or flushed).
PVC Discovery	<ul style="list-style-type: none"> • NOT_VERIFIED—This PVC is manually configured on the router and not yet verified with the attached adjacent switch. • WELL_KNOWN—This PVC has a VCI value of 0 through 31. • DISCOVERED—This PVC is learned from the attached adjacent switch via ILMI. • MIXED—Some of the traffic parameters for this PVC were learned from the switch via ILMI. • MATCHED—This PVC is manually configured on the router, and the local traffic shaping parameters match the parameters learned from the switch. • MISMATCHED—This PVC is manually configured on the router, and the local traffic shaping parameters do not match the parameters learned from the switch. • LOCAL_ONLY—This PVC is configured locally on the router and not on the remote switch.
Status	When the Status field indicates UP, the VC is established. When the Status field indicates DOWN, refer to the State field for further information about the VC state.

Table 13 *show atm pvc Field Descriptions (continued)*

Field	Description
State	<p>When the Status field is UP, this field does not appear. When the Status field is DOWN or INACTIVE, the State field will appear with one of the following values:</p> <ul style="list-style-type: none"> • NOT_VERIFIED—The VC has been established successfully; waiting for OAM (if enabled) and ILMI (if enabled) to verify that the VC is up. • NOT_EXIST—VC has not been created. • HASHING_IN—VC has been hashed into a hash table. • ESTABLISHING—Ready to establish VC connection. • MODIFYING—VC parameters have been modified. • DELETING—VC is being deleted. • DELETED—VC has been deleted. • NOT_IN_SERVICE—ATM interface is shut down.
PPP:	For PPP over ATM, indicates the virtual access interface number and virtual template number being used.

show mpls l2transport binding

To display VC label binding information, use the **show mpls l2transport binding** command in EXEC mode.

```
show mpls l2transport binding [vc-id | ip-address | local-label number | remote-label number]
```

Syntax Description		
<i>vc-id</i>	(Optional)	Displays VC label binding information for the specified VC.
<i>ip-address</i>	(Optional)	Displays VC label binding information for the specified VC destination.
local-label <i>number</i>	(Optional)	Displays VC label binding information for the specified local assigned label.
remote-label <i>number</i>	(Optional)	Displays VC label binding information for the specified remote assigned label.

Command Modes EXEC

Command History	Release	Modification
	12.0(23)S	This command was introduced.
	12.2(14)S	This command was integrated into Cisco IOS Release 12.2(14)S.
	12.2(15)T	This command was integrated into Cisco IOS Release 12.2(15)T.
	12.0(27)S	This command was updated to display AToM Virtual Circuit Connection Verification (VCCV) information.
	12.2(18)SXE	This command was integrated into Cisco IOS Release 12.2(18)SXE.
	12.2(30)S	This command was updated to display Connectivity Verification (CV) type capabilities.

Examples The following example shows the VC label binding information for Cisco IOS Releases 12.0(27)S and 12.2(18)SXE and later:

```
Router# show mpls l2transport binding

Destination Address: 10.0.0.203, VC ID: 1
  Local Label: 16
    Cbit: 1, VC Type: Ethernet, GroupID: 0
    MTU: 1500, Interface Desc: n/a
    VCCV Capabilities: Type 1, Type 2
  Remote Label: 16
    Cbit: 1, VC Type: Ethernet, GroupID: 0
    MTU: 1500, Interface Desc: n/a
    VCCV Capabilities: Type 1, Type 2
```

The following examples shows the VC label binding information for Cisco IOS Release 12.2(30)S and later:

```
Router# show mpls l2transport binding

Destination Address: 5.5.5.51, VC ID: 108
  Local Label: 16
    Cbit: 1, VC Type: Ethernet, GroupID: 0
    MTU: 1500, Interface Desc: n/a
    VCCV: CC Type: CW [1], RA [2]
    CV Type: LSPV [2]
  Remote Label: 16
    Cbit: 1, VC Type: Ethernet, GroupID: 0
    MTU: 1500, Interface Desc: n/a
    VCCV: CC Type: RA [2]
    CV Type: LSPV [2]
```

The output of the command changed between Cisco IOS Releases. The following table maps the older output to the new output:

Output in Cisco IOS Releases 12.0(27)S and 12.2(18)SXE	Output In Cisco IOS Release 12.2(30)S
VCCV Capabilities	VCCV: CC Type
Type 1	CW [1]
Type 2	RA [2]

Table 14 describes the significant fields shown in the display.

Table 14 *show mpls l2transport binding* Field Descriptions

Field	Description
Destination Address	The IP address of the remote router's interface that is at the other end of the VC.
VC ID	The virtual circuit identifier assigned to one of the interfaces on the router.
Local Label	The VC label that a router signals to its peer router, which is used by the peer router during imposition.
Remote Label	The disposition VC label of the remote peer router.
Cbit	The control word bit. If it is set, the value is 1.
VC Type	The type of VC, such as Frame Relay, Ethernet, ATM, and so on.
Group ID	The group ID assigned to the local or remote VCs.
MTU	The maximum transmission unit assigned.
Interface Desc	Interface parameters, if applicable.

Table 14 *show mpls l2transport binding Field Descriptions (continued)*

Field	Description
VCCV Capabilities	<p>(Cisco IOS Releases 12.0(27)S and 12.2(18)SXE and later) AToM VCCV information. This field displays how an AToM VCCV packet is identified.</p> <ul style="list-style-type: none"> • Type 1—The Protocol ID field of in the AToM Control Word (CW) identified the AToM VCCV packet. • Type 2—An MPLS Router Alert (RA) Level above the VC label identified the AToM VCCV packet. Type 2 is used for VC types that do not support or do not interpret the AToM Control Word.
VCCV: CC Type	<p>(Cisco IOS Releases 12.2(30)S and later) The types of Control Channel (CC) processing that are supported. The number indicates the position of the bit that was set in the received octet. The following values can be displayed:</p> <ul style="list-style-type: none"> • CW [1]—Control Word • RA [2]—Router Alert • TTL [3]—Time to Live • Unkn [x]—Unknown
CV Type	<p>(Cisco IOS Releases 12.2(30)S and later) The type of Connectivity Verification (CV) packets that can be processed in the control channel of the MPLS pseudowire. The number indicates the position of the bit that was set in the received octet.</p> <ul style="list-style-type: none"> • ICMP [1]—Internet Control Management Protocol (ICMP) is used to verify connectivity. • LSPV [2]—LSP Ping is used to verify connectivity. • BFD [3]—Bidirectional Forwarding Detection is used to verify connectivity for more than one pseudowire. • Unkn [x]—A CV type was received that could not be interpreted.

Related Commands

Command	Description
show mpls l2transport hw-capability	Displays the transport types and their supported capabilities.

show mpls l2transport hw-capability

To display the transport types supported on an interface, use the **show mpls l2transport hw-capability** command in privileged EXEC mode.

show mpls l2transport hw-capability interface *type number*

Syntax Description

interface	Displays information for the specified interface.
<i>type number</i>	The type and number of the interface. For example, serial6/0.

Command Modes

Privileged EXEC

Command History

Release	Modification
12.0(23)S	This command was introduced.
12.2(14)S	This command was integrated into Cisco IOS Release 12.2(14)S.
12.2(15)T	This command was integrated into Cisco IOS Release 12.2(15)T.
12.0(27)S	This command was updated to display AToM Virtual Circuit Connection Verification (VCCV) information.
12.2(18)SXE	This command was integrated into Cisco IOS Release 12.2(18)SXE.
12.2(30)S	This command was updated to display VCCV type capabilities.

Usage Guidelines

This command can help you determine the interface to use for the various transport types. Use this command to check that core-facing and edge-facing interfaces can accommodate the different transport types.

Examples

The following is partial sample output from the **show mpls l2transport hw-capability** command for Cisco IOS Releases 12.0(23)S, 12.2(14)S, and 12.2(15)T and later. For more information on the fields, see [Table 15](#).

```
Router# show mpls l2transport hw-capability interface serial5/1

Interface Serial5/1

Transport type FR DLCI
  Core functionality:
    MPLS label disposition supported
    Control word processing supported
    Sequence number processing not supported
  Edge functionality:
    MPLS label imposition supported
    Control word processing supported
    Sequence number processing not supported
.
.
.
```

**Note**

These examples show only a portion of the output. The command displays the capabilities of every transport type.

The following is partial sample output from the **show mpls l2transport hw-capability** command for Cisco IOS Releases 12.0(27)S and 12.2(18)SXE and later. This output shows VCCV data under the Core Functionality section. Type 1 means that the AToM Control Word identified the AToM VCCV packet. For more information on the fields, see [Table 15](#).

```
Transport type FR DLCI
Core functionality:
  MPLS label disposition supported
  Control word processing supported
  Sequence number processing not supported
  VCCV CC Type 1 processing supported

Edge functionality:
  MPLS label imposition supported
  Control word processing supported
  Sequence number processing not supported
.
.
.
```

The following is partial sample output from the **show mpls l2transport hw-capability** command for Cisco IOS Releases 12.2(30)S and later. The VCCV output shows that AToM Control Word (CW) identified the AToM VCCV packet. For more information on the fields, see [Table 15](#).

```
Transport type FR DLCI
Core functionality:
  MPLS label disposition supported
  Control word processing supported
  Sequence number processing not supported
  VCCV CC Type CW [1] processing supported

Edge functionality:
  MPLS label imposition supported
  Control word processing supported
  Sequence number processing not supported
.
.
.
```

The output of the command changed between Cisco IOS Releases. The following table maps the older output to the new output:

Output in Cisco IOS Releases 12.0(27)S and 12.2(18)SXE and later	Output In Cisco IOS Release 12.2(30)S
VCCV CC processing supported	VCCV CC processing supported
Type 1	Type CW [1]

[Table 15](#) describes the significant fields shown in the display.

Table 15 *show mpls l2transport hw-capability Field Descriptions*

Field	Description
Transport type	Indicates the transport type.
Core functionality	Displays the functionalities that the core-facing interfaces support, such as label disposition, and control word and sequence number processing.
VCCV CC Type processing supported	<p>Displays whether the core-facing interfaces support Control Word processing, or Router Alert Processing.</p> <p>(Cisco IOS Releases 12.0(27)S and 12.2(18)SXE and later)</p> <ul style="list-style-type: none"> • Type 1—The Protocol ID field of in the AToM Control Word (CW) identified the AToM VCCV packet. <p>(Cisco IOS Releases 12.2(30)S and later)</p> <ul style="list-style-type: none"> • CW [1]—Control Word • Unkn [x]—Unknown. The number indicates the position of the bit that was set in the received octet.
Edge functionality	Displays the functionalities that the edge-facing interfaces support, such as label disposition, and control word and sequence number processing.

show mpls l2transport summary

To display summary information about virtual circuits (VCs) that have been enabled to route Any Transport over MPLS (AToM) Layer 2 packets on a router, use the **show mpls l2transport summary** command in EXEC mode.

show mpls l2transport summary

Syntax Description This command has no arguments or keywords.

Command Modes EXEC

Command History	Release	Modification
	12.0(23)S	This command was introduced.
	12.2(14)S	This command was integrated into Cisco IOS Release 12.2(14)S.
	12.2(15)T	This command was integrated into Cisco IOS Release 12.2(15)T.

Examples The following sample output shows summary information about the VCs that have been enabled to transport Layer 2 packets:

```
Router# show mpls l2transport summary

Destination address: 172.56.2.2 Total number of VCs: 60
0 unknown, 58 up, 0 down, 2 admin down
5 active vc on MPLS interface PO4/0
```

[Table 16](#) describes the fields used in the example.

Table 16 *show mpls l2transport summary Field Descriptions*

Field	Description
Destination address	The IP address of the remote router to which the VC has been established.
Total number of VCs	The number of VCs that have been established.
unknown	The number of VCs that are in an unknown state.
up	The number of VCs that are operational.
down	The number of VCs that are not operational.
admin down	The number of VCs that have been disabled.

show mpls l2transport vc

To display information about Any Transport over MPLS (AToM) virtual circuits (VCs) that have been enabled to route Layer 2 packets on a router, use the **show mpls l2transport vc** command in EXEC mode.

```
show mpls l2transport vc [vcid vc-id] [vc-id-min vc-id-max] [interface name [local-circuit-id]]
[destination ip-address | name] [detail]
```

Syntax Description

vcid	(Optional) The VC ID assigned to the router.
<i>vc-id</i>	(Optional) The VC ID.
<i>vc-id-min</i> and <i>vc-id-max</i>	(Optional) The VCs that are assigned the range of VC IDs that you specify. The range is from 1 to 4,294,967,295. (This argument is primarily for legacy implementations.)
interface	(Optional) The interface or subinterface of the router that has been enabled to transport Layer 2 packets. This keyword lets you display information about the VCs that have been assigned VC IDs on that interface or subinterface.
<i>name</i>	(Optional) The name of the interface or subinterface.
<i>local-circuit-id</i>	(Optional) The number assigned to the local circuit. This argument value applies only to the following transport types: <ul style="list-style-type: none"> • For Frame Relay, enter the DLCI of the PVC. • For ATM AAL5 and Cell Relay, enter the VPI/VCI of the PVC. • For Ethernet VLANs, enter the VLAN number.
destination	(Optional) Information about the VCs that have been assigned VC IDs for the remote router you specify.
<i>ip-address</i>	(Optional) The IP address of the remote router.
<i>name</i>	(Optional) The name assigned to the remote router.
detail	(Optional) Detailed information about the VCs that have been assigned VC IDs.

Defaults

If you do not specify any keywords or arguments, the command displays a summary of all the VCs.

Command Modes

EXEC

Command History

Release	Modification
12.1(8a)E	This command was introduced.
12.0(21)ST	This command was integrated into Cisco IOS Release 12.0(21)ST.
12.0(23)S	This command was updated to include the interface and destination keywords.
12.2(14)S	This command was integrated into Cisco IOS Release 12.2(14)S.
12.2(15)T	This command was integrated into Cisco IOS Release 12.2(15)T.

Examples

The output of the commands varies, depending on the type of Layer 2 packets being transported over the AToM VCs.

The following example shows information about the interfaces and VCs that have been configured to transport various Layer 2 packets on the router:

```
Router# show mpls l2transport vc
```

Local intf	Local circuit	Dest address	VC ID	Status
Se5/0	FR DLCI 55	13.0.0.1	55	UP
AT4/0	ATM AAL5 0/100	13.0.0.1	100	UP
AT4/0	ATM AAL5 0/200	13.0.0.1	200	UP
AT4/0.300	ATM AAL5 0/300	13.0.0.1	300	UP

Table 17 describes the significant fields displayed in the output.

Table 17 show mpls l2transport vc Field Descriptions

Field	Description
Local intf	The interface on the local router that has been enabled to transport Layer 2 packets.
Local circuit	The type and number (if applicable) of the local circuit. The output shown in this column varies, according to transport type: <ul style="list-style-type: none"> For Frame Relay, the output shows the DLCI of the PVC. For ATM cell relay and AAL5, the output shows the VPI/VCI of the PVC. For Ethernet VLANs, the output shows the VLAN number. For PPP and HDLC, the output shows the interface number.
Dest address	The IP address of the remote router's interface that is the other end of the VC.
VC ID	The virtual circuit identifier assigned to one of the interfaces on the router.
Status	The status of the VC. The status can be one of the following: <p>UP—The VC is in a state where it can carry traffic between the two VC endpoints. A VC is up when both imposition and disposition interfaces are programmed.</p> <ul style="list-style-type: none"> The disposition interfaces is programmed if the VC has been configured and the client interface is up. The imposition interface is programmed if the disposition interface is programmed and we have a remote VC label and an IGP label. The IGP label can be implicit null in a back-to-back configuration. (An IGP label means there is an LSP to the peer.) <p>DOWN—The VC is not ready to carry traffic between the two VC endpoints. Use the detail keyword to determine the reason that the VC is down.</p> <p>ADMIN DOWN—The VC has been disabled by a user.</p>

The following example shows information about VCs that have been configured to transport Layer 2 packets:

```

Router# show mpls l2transport vc detail

Local interface: local interface up, line protocol up, local circuit 16 up
Destination address: 13.13.13.13, VC ID: 100, VC status: up
  Tunnel label: imp-null, next hop point2point
  Output interface: PO0/1/0, imposed label stack {16}
  Create time: 00:16:44, last status change time: 00:15:45
  Signaling protocol: LDP, peer 13.13.13.13:0 up
  MPLS VC labels: local 16, remote 16
  Group ID: local 12, remote 1
  MTU: local 1500, remote 1500
  Remote interface description:
  Sequencing: receive disabled, send disabled
  VC statistics:
    packet totals: receive 56, send 55
    byte totals:   receive 10181, send 10569
    packet drops:  receive 0, send 0

```

Table 18 describes the significant fields displayed in the output.

Table 18 *show mpls l2transport vc detail* Field Descriptions

Field	Description
<i>Local interface</i>	The interface on the local router that has been enabled to transmit and receive Layer 2 packets. The interface varies, depending on the transport type. The output also shows the status of the interface.
line protocol	The status of the line protocol on the edge-facing interface.
<i>local circuit</i>	The type, number (if applicable) and status of the local circuit. The output varies, depending on the transport type: <ul style="list-style-type: none"> For Frame Relay, the output shows the DLCI of the PVC. For ATM cell relay and AAL5, the output shows the VPI/VCI of the PVC. For Ethernet VLANs, the output shows the VLAN number.
Destination address	The IP address of the remote router specified for this VC. You specify the destination IP address as part of the mpls l2transport route command.
VC ID	The virtual circuit identifier assigned to the interface on the router.
VC status	The status of the VC. The status can be one of the following: <p>UP—The VC is in a state where it can carry traffic between the two VC endpoints. A VC is up when both imposition and disposition interfaces are programmed.</p> <ul style="list-style-type: none"> The disposition interface is programmed if the VC has been configured and the client interface is up. The imposition interface is programmed if the disposition interface is programmed and a remote VC label and an IGP label exist. The IGP label can be an implicit null in a back-to-back configuration. (An IGP label means there is a LSP to the peer.) <p>DOWN—The VC is not ready to carry traffic between the two VC endpoints.</p> <p>ADMIN DOWN—The VC has been disabled by a user.</p>

Table 18 *show mpls l2transport vc detail Field Descriptions*

Field	Description
Tunnel label	<p>An IGP label used to route the packet over the MPLS backbone to the destination router with the egress interface. The first part of the output displays the type of label. The second part of output displays the route information.</p> <p>The tunnel label information can display any of the following states:</p> <p>imp-null: The P router is absent and the tunnel label will not be used. Alternatively, imp-null can signify traffic engineering tunnels between the PE routers.</p> <p>unassigned: The label has not been assigned.</p> <p>no route: The label is not in the routing table.</p> <p>no adjacency: The adjacency for the next hop is missing.</p> <p>not ready, no route: An IP route for the peer does not exist in the routing table.</p> <p>not ready, not a host table: The route in the routing table for the remote peer router is not a host route.</p> <p>not ready, CEF disabled: CEF is disabled.</p> <p>not ready, LFIB disabled: The MPLS switching subsystem is disabled.</p> <p>not ready, LFIB entry present: The tunnel label exists in the LFIB, but the VC is down.</p>
Output interface	The interface on the remote router that has been enabled to transmit and receive Layer 2 packets.
imposed label stack	Summary of the MPLS label stack used to direct the VC to the PE router.
Create time	The time when the VC was provisioned.
last status change time	The last time the VC state changed.
Signaling protocol	The type of protocol used to send the MPLS labels. The output also shows the status of the peer router.
MPLS VC labels	The local VC label is a disposition label, which determines the egress interface of an arriving packet from the MPLS backbone. The remote VC label is a disposition VC label of the remote peer router.
Group ID	The local group ID is used to group VCs locally. The remote group ID is used by the peer to group several VCs.
MTU	The maximum transmission unit specified for the local and remote interfaces.
Remote interface description	The interface on the remote router that has been enabled to transmit and receive Layer 2 packets.
Sequencing	This field describes whether sequencing of out-of-order packets is enabled or disabled.
packet totals	The number of packets sent and received. Received packets are those AToM packets received from the MPLS core. Sent packets are those AToM packets sent to the MPLS core. This does not include dropped packets.

Table 18 *show mpls l2transport vc detail Field Descriptions*

Field	Description
byte totals	The number of packets sent and received from the core-facing interface, including the payload, VC label, and AToM control word (if present)..
packet drops	The number of packets that were dropped as they were sent or received from the core-facing interface.

■ `show mpls l2transport vc`