



Terminal Services Overview

This chapter provides an overview of Cisco IOS terminal services and includes the following main sections:

- [Cisco IOS Network Access Devices](#)
- [Line Characteristics and Modems](#)
- [Asynchronous Character Stream Calls](#)
- [Remote Node Services](#)
- [Terminal Services](#)
- [Protocol Translation](#)

Cisco IOS Network Access Devices

Network devices that support access services enable single users to access network resources from remote sites. Remote users include corporate telecommuters, mobile users, and individuals in remote offices who access the central site. Access services connect remote users over serial lines to modems, networks, terminals, printers, workstations, and other network resources on LANs and WANs. In contrast, routers that do not support access services connect LANs or WANs.



Note

Access services are supported on the Cisco 2500, Cisco 2600, and Cisco 3600 series routers. See the *Cisco Products Quick Reference Guide*, available at Cisco.com, for more information about Cisco devices for terminal and modem access services.

[Figure 2](#) illustrates the following access services available in the Cisco IOS software:

- Terminal services are shown between the terminals and hosts running the same protocol (LAT to LAT or TCP to TCP).
- Protocol translation is supported between the terminals and hosts running unlike protocols (such as LAT to TCP or TCP to LAT).

Asynchronous IP routing is shown by the PC running Serial Line Internet Protocol (SLIP) or Point-to-Point Protocol (PPP), and between the two access servers. Asynchronous routing configuration is described in the *Cisco IOS Terminal Services Configuration Guide*, Release 12.2.

Figure 2 Access Service Functions

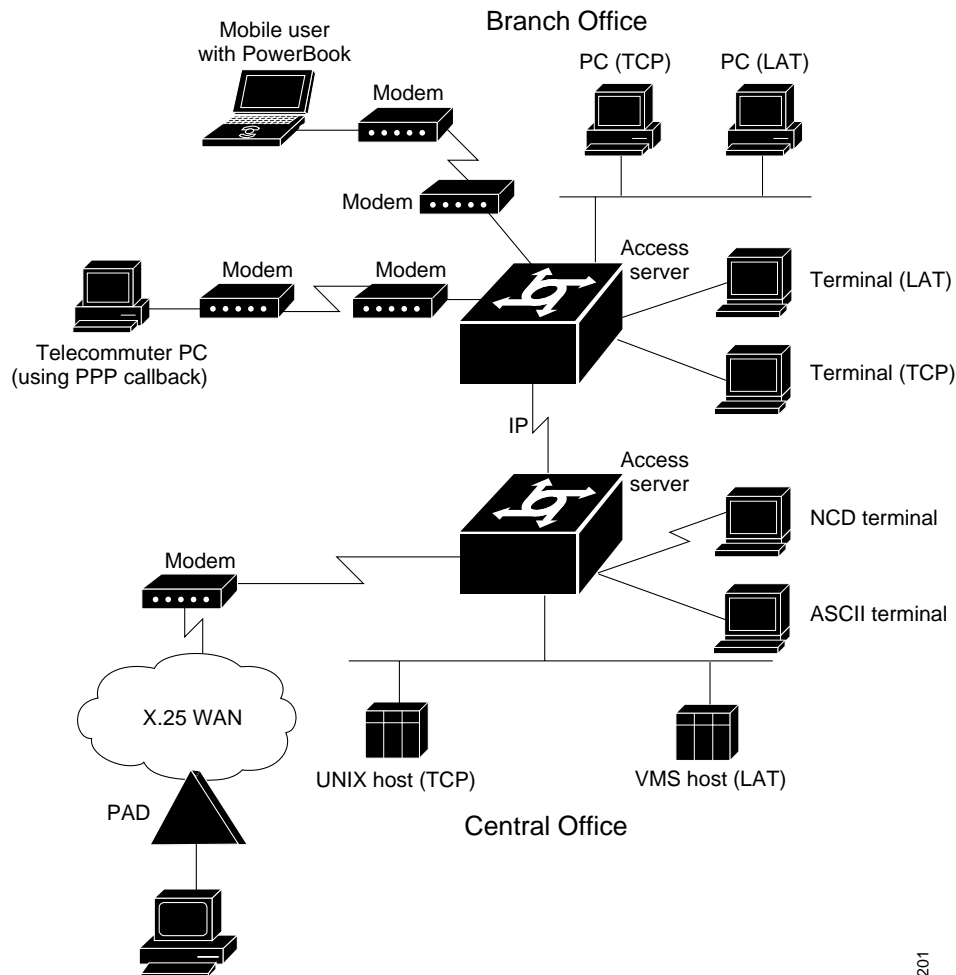

Line Characteristics and Modems

The Cisco IOS software permits you to connect to asynchronous serial devices such as terminals and modems and to configure custom device operation. You can configure a single physical or virtual line or a range of lines. For example, you can configure one line for a laser printer and then configure a set of lines to switch incoming modem connections to the next available line. You also can customize your configurations. For example, you can define line-specific transport protocols, control character, and packet transmissions, set line speed, flow control, and establish time limits for user access.

The chapters in this publication describe how to configure the lines for a specific device application. See the chapter [“Configuring Protocol Translation and Virtual Asynchronous Devices”](#) in this publication, and the chapters [“Interfaces, Controllers, and Lines Used for Dial Access Overview”](#) and [“Preparing Modem and Asynchronous Interfaces”](#) in the *Cisco IOS Dial Technologies Configuration Guide* for additional information about configuring Cisco asynchronous serial interfaces.

Asynchronous Character Stream Calls

Asynchronous character stream calls enter the router or access server through virtual terminal (vty) lines and virtual asynchronous interfaces (vty-async). These virtual lines and interfaces terminate incoming character streams that have no physical connection to the access server or router (such as a physical serial interface). For example, if you begin a PPP session over an asynchronous character stream, a vty-async interface is created to support the call. The following types of calls are terminated on a virtual asynchronous interface: Telnet, local-area transport (LAT), V.120, TN3270, and Link Access Procedure, Balanced-terminal adapter (LAPB-TA) and packet assembler/disassembler (PAD) calls.

Figure 3 shows a dumb terminal using a modem and packet assembler/disassembler (PAD) to place a call in to an X.25 switched network. The Cisco 4700-M router is configured to support vty lines and vty-async interfaces.

Figure 3 Standard X.25 Dial-Up Connection

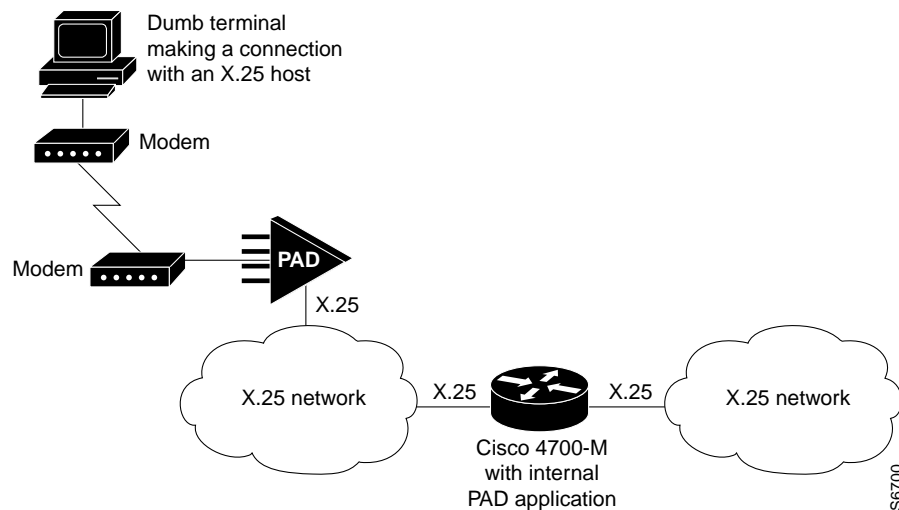

Remote Node Services

Remote node services permit remote users to connect devices over a telephone network using the following protocols:

- AppleTalk Remote Access (ARA), which is described in the chapter “[Configuring AppleTalk Remote Access](#)” in this publication.

Using ARA, Macintosh users can connect across telephone lines into an AppleTalk network to access network resources, such as printers, file servers, and e-mail. Remote users running ARA have the same access to network resources as a Macintosh connected directly to the LAN. They can also run other applications on top of ARA to access UNIX file servers for such tasks as reading e-mail and copying or transferring files between UNIX hosts. Note that Macintosh users can run Macintosh-based SLIP or PPP applications to access non-AppleTalk-based resources (see [Figure 4](#)).

Figure 4 Remote Node Connection—Macintosh and PC Users Dialing In

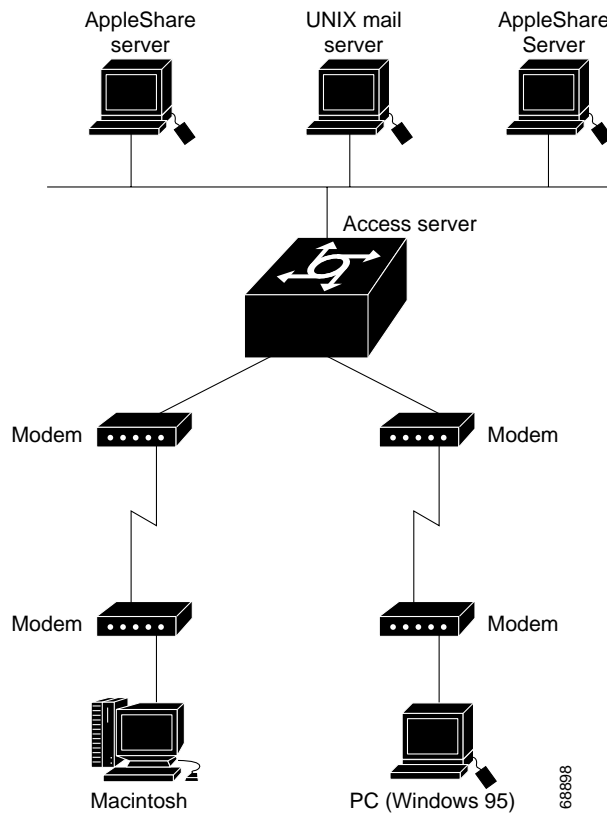

- XRemote, the Network Control Device, Inc. (NCD) X Window Systems terminal protocol, which is described in the section “[Configuring XRemote](#)” in the “[Configuring Dial-In Terminal Services](#)” chapter in this publication.

Remote users with X terminals, such as NCD terminals, use the XRemote protocol over asynchronous lines. The router provides network functionality to remote X terminals. [Figure 5](#) illustrates an XRemote connection.

Figure 5 XRemote Connection

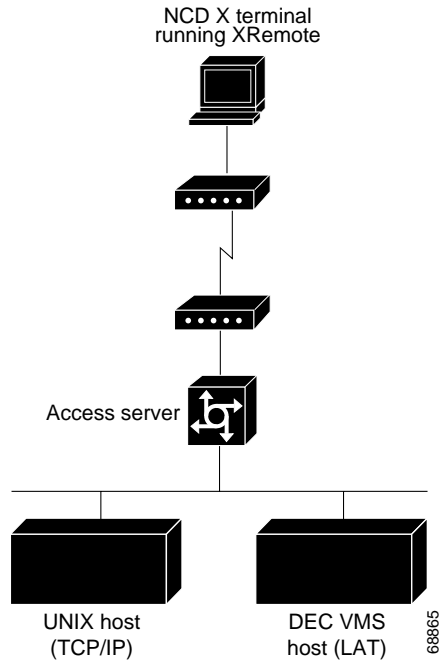

- NetWare Access Server Interface (NASI) server, which is described in the chapter “[Configuring Support for NASI Clients to Access Network Resources](#)” in this publication. Configuring a NASI server enables NASI clients to connect to asynchronous resources attached to a router. NASI clients are connected to the Ethernet interface 0 on the router. When the user on the NASI client uses the Windows or DOS application to connect to the router, a list of available terminal and virtual terminal lines appears. The user selects the desired outgoing terminal and virtual terminal port. (See [Figure 6.](#))

Figure 6 NASI Setup in a NetWare Environment

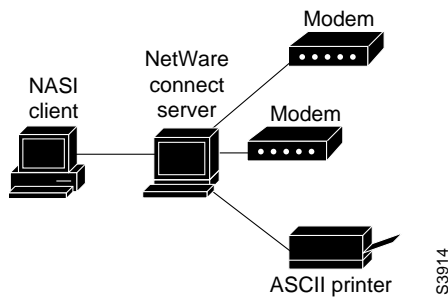

Terminal Services

Terminal services permit asynchronous devices to be connected to a LAN or WAN through network and terminal-emulation software including Telnet, rlogin, NASI, the Digital local-area transport (LAT) protocol, and IBM TN3270. (See [Figure 7](#).)

Access services permit terminals to connect with remote hosts using virtual terminal protocols including Telnet, NASI, LAT, TN3270, rlogin, and X.25 packet assembler/disassembler (PAD). You can use a router that supports access services to function as a terminal server to provide terminal access to devices on the network.

A host can also connect directly to an access server. In IBM environments, TN3270 allows a standard ASCII terminal to emulate a 3278 terminal and access an IBM host across an IP network.

In Digital environments, LAT support provides a terminal with connections to VMS hosts. X.25 PAD allows terminals to connect directly to an X.25 host over an X.25 network through the router. X.25 PAD eliminates the need for a separate PAD device. This connection requires use of one of the synchronous serial interfaces on the router supporting access services.

Figure 7 Terminal-to-Host Connectivity

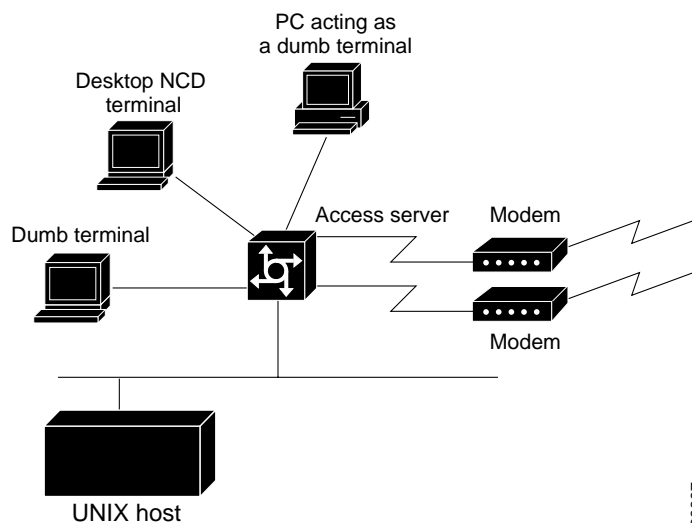

Protocol Translation

Protocol translation services are essentially an extension of terminal services. A user running a TCP/IP-based application can connect to a host running a different virtual terminal protocol, such as the Digital LAT protocol. The Cisco IOS software converts one virtual terminal protocol into another protocol. Protocol translation enables users to make connections to X.25 machines using X.25 PAD.

Routers translate virtual terminal protocols to allow communication between devices running different protocols. Protocol translation supports Telnet (TCP), LAT, and X.25. One-step protocol translation software performs bidirectional translation between any of the following protocols:

- X.25 and TCP
- X.25 and LAT
- LAT and TCP

Figure 8 illustrates LAT-to-TCP protocol translation.

Figure 8 LAT-to-TCP Protocol Translation

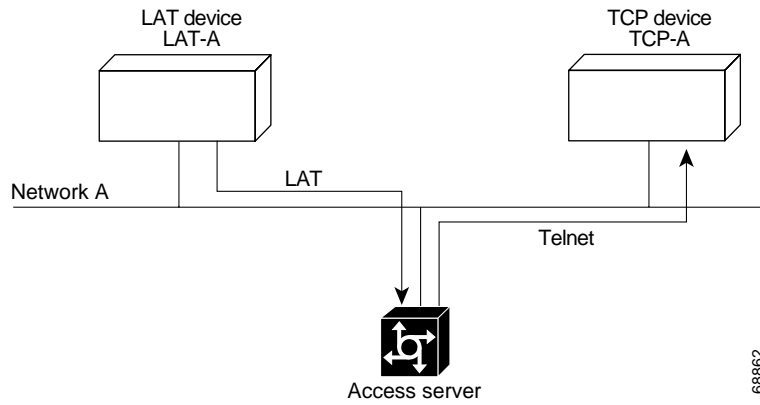

Connecting to IBM hosts from LAT, Telnet, rlogin, and X.25 PAD environments requires a two-step translation process. In other words, users must first establish a connection with the router, then use the TN3270 facility to make a connection to the IBM host.

