



Configuring NCIA Client/Server

This chapter describes native client interface architecture (NCIA) support for Systems Network Architecture (SNA) devices. NCIA server and the NCIA client/server model extends the scalability of NCIA I, the earlier NCIA implementation, by minimizing the number of central-site remote source-route bridging (RSRB) or data-link switching plus (DLSw+) peer connections required to support a large number of NCIA clients. For a complete description of the NCIA client/server commands mentioned in this chapter, refer to the “NCIA Server Configuration Commands” chapter of the *Cisco IOS Bridging and IBM Networking Command Reference* (Volume 1 of 2). To locate documentation of other commands that appear in this chapter, use the command reference master index or search online.

This chapter contains the following sections:

- [Technology Overview, page 471](#)
- [Configuring NCIA Server Session to Local Token Ring Using DLSw+ Local Switch, page 475](#)
- [Configuring NCIA Server Session with DLSw+, page 477](#)
- [Configuring NCIA Server Session with DSPU, page 479](#)
- [Configuring NCIA Server Session with RSRB, page 481](#)
- [Monitoring and Maintaining an NCIA Server Network, page 484](#)
- [NCIA Server Configuration Examples, page 485](#)

To identify the hardware platform or software image information associated with a feature, use the Feature Navigator on Cisco.com to search for information about the feature or refer to the software release notes for a specific release. For more information, see the “[Identifying Platform Support for Cisco IOS Software Features](#)” section on page li in the “Using Cisco IOS Software” chapter.

Technology Overview

Cisco’s NCIA server feature implements RFC 2114, *Data Link Switch Client Access Protocol*. Using Cisco’s RSRB technology, NCIA I encapsulates the Token Ring traffic inside IP datagrams passed over a TCP connection between a router and a client. A virtual ring is created to allow the router to interconnect any client. The virtual ring acts as a logical Token Ring in the router, so that all the Token Rings connected to the router are treated as if they are all on the same Token Ring. The virtual ring is called a ring group. The ring group number is used just like a physical ring number and shows up in any route descriptors contained in packets being bridged. A ring group must be assigned a ring number that is unique throughout the network.

An NCIA I client acts as both an RSRB router and an end station. It must have a “fake” ring number and a “fake” bridge number so that it looks like an end station sitting on a real Token Ring. The fake ring and bridge numbers are visible to both the RSRB router and the NCIA client. The client must also have an LLC2 so that it can handle the LLC2 sessions.

NCIA Server

The NCIA Server feature extends the scalability of NCIA I, enhances its functionality, and provides support for both the installed base of RSRB routers and the growing number of DLSw+ routers. The NCIA Server feature includes the following enhancements:

- You do not need to configure a ring number on the client.
- You do not need to configure each client on the router.
- The MAC address can be dynamically assigned by the NCIA server running on the router.
- SNA is directly on top of TCP/IP; LLC2 is no longer required at end station.
- A client is a true end station, not a router peer.
- The NCIA Server communicates with other components in router, such as RSRB, SNA Switching Services (SNASw), DLSw+, and DSPU.
- Supports both connect-in and connect-out.
- The NCIA client/server model is independent of the upstream implementation.
- It is an efficient protocol between client and server.

NCIA Client/Server Model

The NCIA Server feature uses a client/server model (Figure 199), where the NCIA server is a software module on a Cisco router and the NCIA client is a PC or workstation. The NCIA server performs two major functions:

- Establishes TCP to NCIA data-link Control (NDLC) sessions with clients for the purpose of sending and receiving data.
- Uses the Cisco link services interface (CLSI) to communicate with other software modules in the router, such as SNASw, DLSw+, and DSPU, and acts as the data intermediary between them and NCIA clients. The NCIA server’s role as an intermediary is transparent to the client.

Figure 199 NCIA Server Client/Server Model

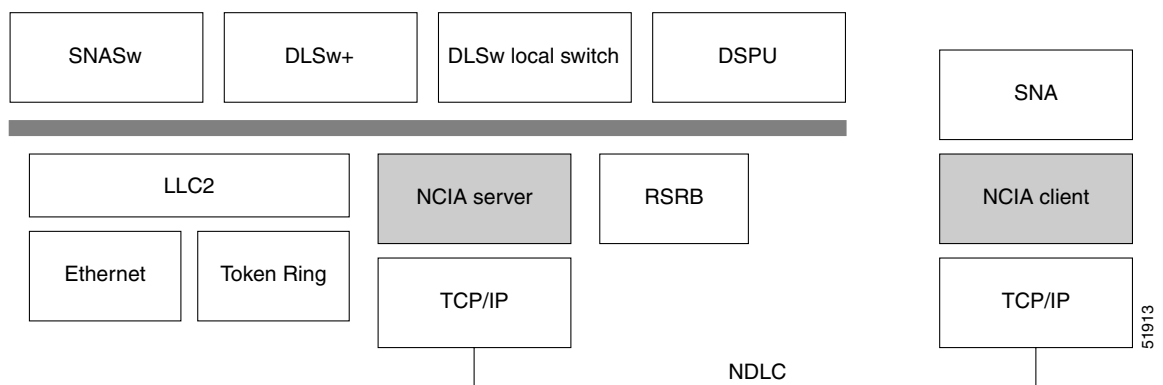

NDLC is the protocol used between clients and servers. NDLC serves two purposes:

- Establishes the peer connection.
- Establishes the circuit between the client and the server.

The peer session must be established before an end-to-end circuit can be set up. During the set up period for the peer session, the MAC address representing a client is defined. The MAC address can be defined by the client or by the server when the client does not have a MAC address.

The NCIA Server feature supports connect-in and connect-out (from the server's perspective), but connect-out is not supported if the client station does not listen for the incoming connection. For a server to connect-out, clients must connect to the server first. After registering itself by providing its own MAC address, the client can then optionally disconnect from the server. When a server receives an explorer, and its destination MAC address is registered, an NCIA server will connect to that client if it is not connected. For NetBIOS explorers (addressed to functional address 0xC0000000080), the TCP session must remain up so that the server can broadcast the explorers to the client. If the TCP session is down, the server will not send the NetBIOS explorers to a client, even when the client is registered.

After the peer session has been established, the NDLC protocol establishes the circuit between the client and server. This circuit is used to transfer end-user data between the client and the server. Because the client and its target station are not on the same transport, they cannot form a direct, end-to-end circuit. Each client must form a circuit between the client and server, and the server must form another circuit between the server and the target station. The server links those two circuits to form an end-to-end circuit. The server acts as a mediator between the client and the target station so that packets can be transferred between them.

In the NCIA server only peer keepalive is maintained. There is no keepalive at circuit level.

The NCIA server acts as a data-link provider, like Token Ring or Ethernet, in the router. It uses CLSI to communicate with other software modules, just as other data-link providers do. The network administrator configures the router to communicate with specific modules. For data-link users, such as SNASw, DLSw+, and DSPU, the NCIA server can interface to them directly. For other data-link providers, the NCIA server must go through a DLSw+ local peer to communicate with them. The DLSw+ local peer passes packets back and forth among different data-link providers.

Advantages of the Client/Server Model

The client/server model used in the NCIA Server feature extends the scalability of NCIA. In addition, it provides support for both the installed base of RSRB routers and the growing number of DLSw+ routers.

Extended Scalability

The client/server model minimizes the number of central site RSRB or DLSw+ peer connections required to support a large network of NCIA clients (Figure 200). Rather than each client having a peer connection to a central site router, the clients attach to an IP backbone through an NCIA server that, in turn, has a single peer connection to a central site router. This scheme can greatly reduce the number of central site peer connections required. For example, in a network with 1000 clients and 10 NCIA servers, there would be only 10 central site peer connections. Note that there would still be 1000 LLC2 connections that must be locally acknowledged at the central site router, but this can easily be handled in a single central site router. When the number of LLC2 connections (or the number of clients) is in the tens of thousands, NCIA servers can take advantage of downstream PU concentration to minimize the number of LLC2 connections that must be supported by the central site routers.

Figure 200 NCIA Server Provides Extended Scalability to Support Large Networks

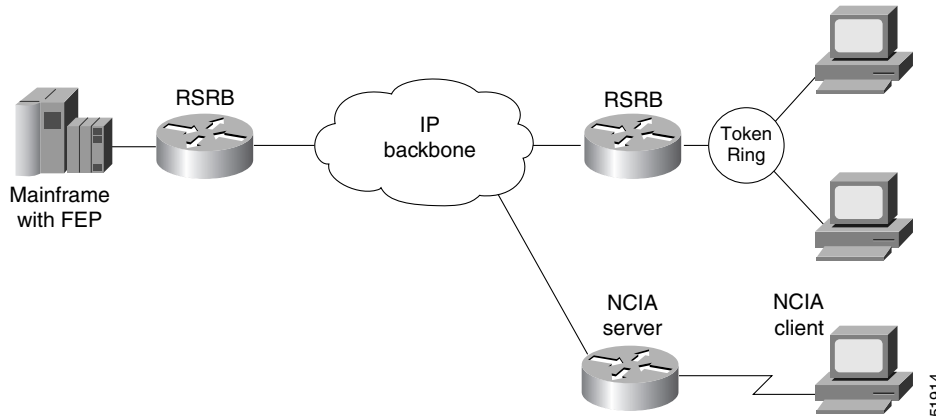

Migration Support

Using a client/server model allows the NCIA Server feature to be independent of the upstream implementation, allowing it to be implemented in a network that is still using RSRB and in a DLSw+ network. It also greatly simplifies migration from RSRB to DLSw+, because it requires no changes at the client. A single NCIA server can support either approach (but not both). As Figure 201 illustrates, a central site router can support RSRB and DLSw+ concurrently, allowing a portion of the NCIA servers to communicate using RSRB and another portion to communicate using DLSw+.

Figure 201 NCIA Server Provides Independence from the Upstream Network Implementation

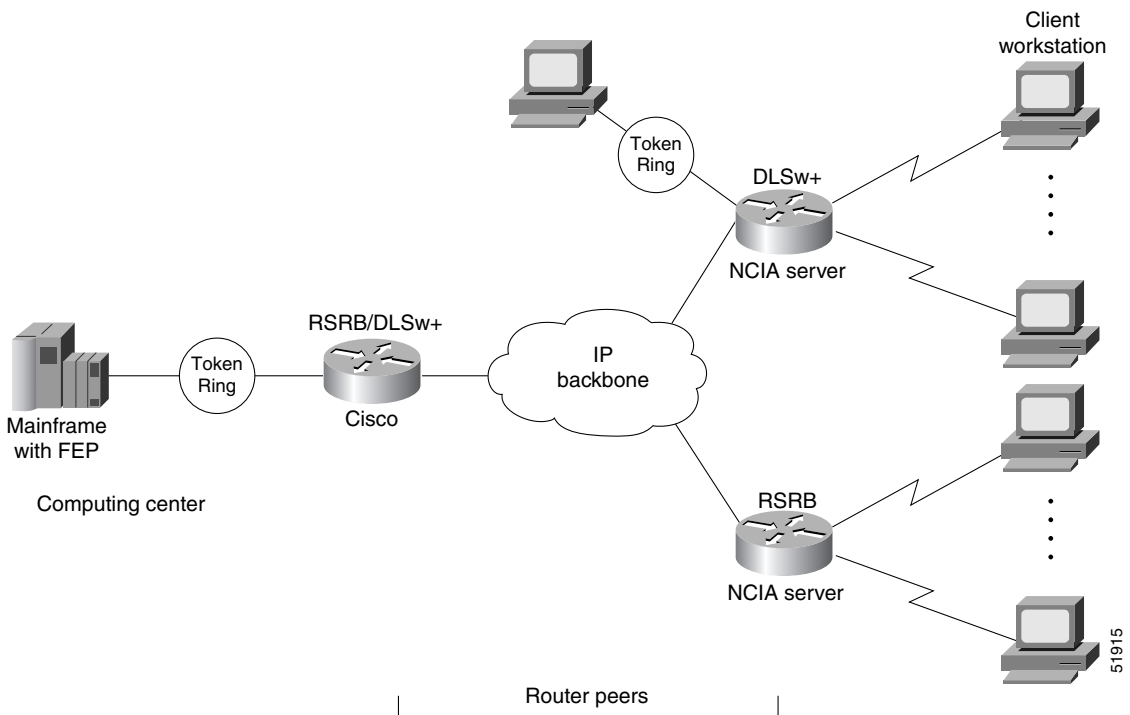

Configuring NCIA Server Session to Local Token Ring Using DLSw+ Local Switch

The network configuration shown in [Figure 202](#) includes NCIA clients that connect to a front-end processor (FEP) on a Token Ring through a local router (the NCIA server). The virtual ring is used in conjunction with DLSw+ local switch. The routing information field (RIF) of each circuit is terminated on the virtual ring. [Figure 203](#) shows a logical view of an NCIA server session using a DLSw+ local switch (connected to a local Token Ring). In addition to Token Ring, an NCIA server also supports Ethernet, Synchronous Data Link Control (SDLC) Protocol, and Qualified Logical Link Control (QLLC) network connections, and Channel Interface Processor (CIP) connections through a DLSw+ local switch. For more information on the different media types that a DLSw+ local switch supports, refer to the “Configuring DLSw+” chapter.

Figure 202 NCIA Server Session to Local Token Ring Using DLSw+ Local Switch

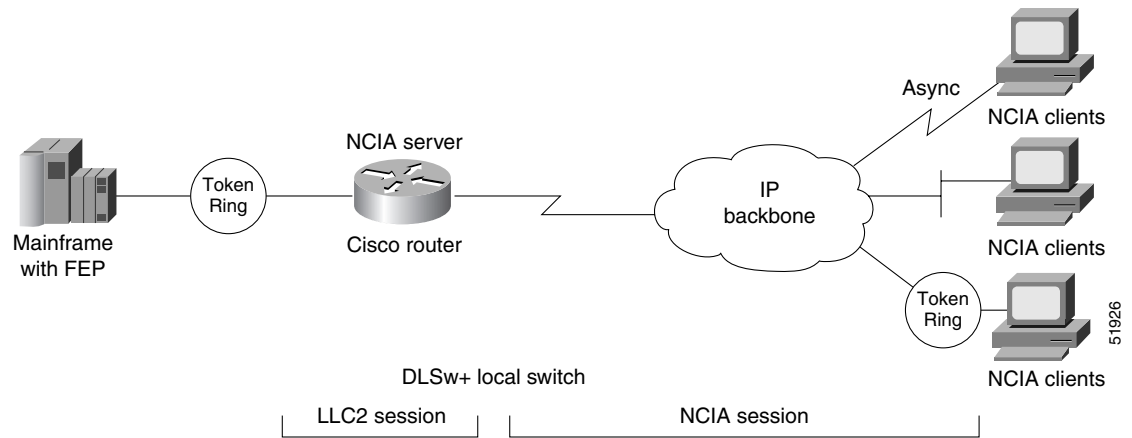
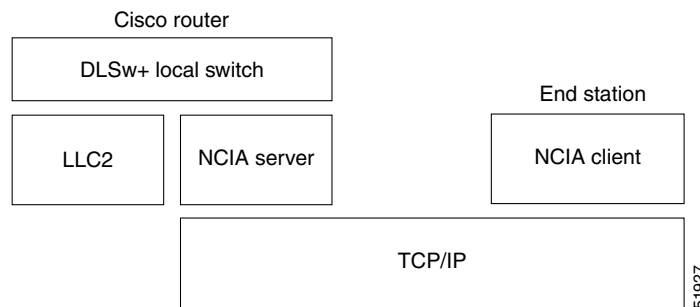

Figure 203 Logical View of NCIA Server Session to a Local Token Ring Using DLSw+ Local Switch



Configuration Task List

To configure an NCIA server session connected to a local Token Ring, perform the tasks in the following sections:

- [Defining a Source-Bridge Ring Group for DLSw+, page 476](#)
- [Defining a DLSw+ Local Peer for the Router, page 476](#)
- [Configuring an NCIA Server on the Router, page 476](#)

For a configuration example, see the “[NCIA Server Session to Local Token Ring Using DLSw+ Local Switch Example](#)” section on page 485.

Defining a Source-Bridge Ring Group for DLSw+

In DLSw+, the source-bridge ring group specifies the virtual ring that will appear to be the last ring in the RIF. This ring is transparent to the NCIA client. From the host’s point of view, all NCIA clients look like stations sitting on the virtual ring. To define a source-bridge ring group for DLSw+, use the following command in global configuration mode:

Command	Purpose
Router(config)# source-bridge ring-group <i>ring-group</i> [<i>virtual-mac-address</i>]	Defines a ring group.

Defining a DLSw+ Local Peer for the Router

Defining a DLSw+ local peer for a router enables a DLSw+ local switch. You specify all local DLSw+ parameters as part of the local peer definition. To define a local peer, use the following command in global configuration mode:

Command	Purpose
Router(config)# dls w local-peer [<i>peer-id ip-address</i>] [group <i>group</i>] [border] [cost <i>cost</i>] [lf <i>size</i>] [keepalive <i>seconds</i>] [passive] [promiscuous] [biu-segment]	Defines the DLSw+ local peer.

Configuring an NCIA Server on the Router

Configuring an NCIA server on a router enables the router to perform two roles:

- Establish TCP/NDLC sessions with clients for the purpose of sending and receiving data.
- Use the standard interface (CLSI) to communicate with other software modules in the router, such as DLSw+, and DSPU, and act as the data intermediary between them and the clients of the NCIA server.

To configure an NCIA server, use the following command in global configuration mode:

Command	Purpose
<pre>Router(config)# ncia server server-number server-ip-address server-virtual-mac-address virtual-mac-address virtual-mac-range [inbound-only] [keepalive seconds] [tcp_keepalive minutes]</pre>	Configures the NCIA server.

Configuring NCIA Server Session with DLSw+

In the network configuration shown in Figure 204, the NCIA server uses DLSw+ to connect its clients to the FEP through a remote router. Figure 205 shows a logical view of the NCIA Server session with DLSw+.

Figure 204 NCIA Server Session with DLSw+

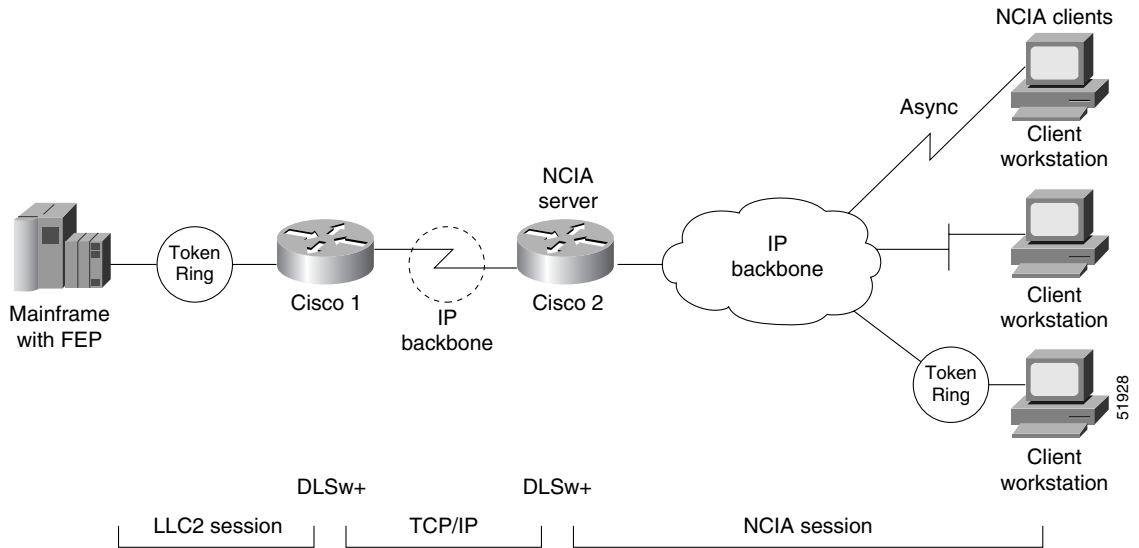
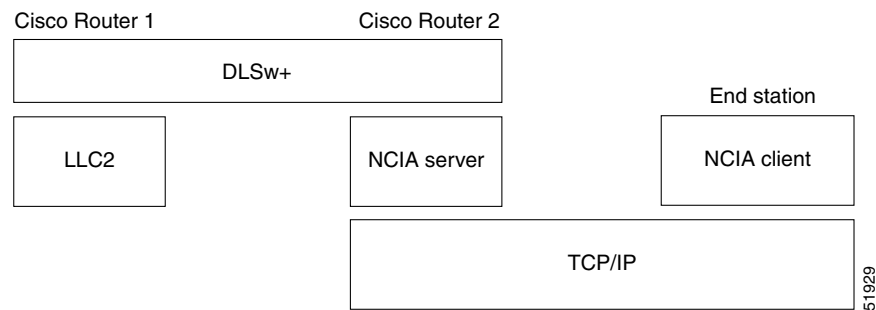

Figure 205 Logical View of NCIA Server with DLSw+



DLSw+ Configuration Task List

To configure an NCIA server session connected to a remote router using DLSw+, perform the tasks in the following sections:

- [Defining a Source-Bridge Ring Group for DLSw+, page 478](#)
- [Defining a DLSw+ Local Peer for the Router, page 478](#)
- [Defining a DLSw+ Remote Peer, page 478](#)
- [Configuring an NCIA Server on the Local Router, page 479](#)

For a configuration example, see the “NCIA Server Session with DLSw+ Example” section on page 486.

Defining a Source-Bridge Ring Group for DLSw+

The source-bridge ring can be shared between DLSw+ and SRB/RSRB. In DLSw+, the source-bridge ring group specifies the virtual ring that will appear to be the last ring in the RIF. Because RIFs are terminated at the router, there is no correlation between the ring-group number specified in DLSw+ peers. The numbers can be the same for management simplicity, but they do not have to be. To define a source-bridge ring group for DLSw+, use the following command in global configuration mode:

Command	Purpose
Router(config)# source-bridge ring-group <i>ring-group</i> [<i>virtual-mac-address</i>]	Defines a ring group.

Defining a DLSw+ Local Peer for the Router

Defining a DLSw+ local peer for a router enables DLSw+. You specify all local DLSw+ parameters as part of the local peer definition. To define a local peer, use the following command in global configuration mode:

Command	Purpose
Router(config)# dls w local-peer [<i>peer-id ip-address</i>] [group <i>group</i>] [border] [cost <i>cost</i>] [lf <i>size</i>] [keepalive <i>seconds</i>] [passive] [promiscuous] [biu-segment]	Defines the DLSw+ local peer.

Defining a DLSw+ Remote Peer

To configure TCP encapsulation on a remote peer, use the following command in global configuration mode:

Command	Purpose
Router(config)# dls w remote-peer <i>list-number tcp ip-address</i> [backup-peer <i>ip-address</i>] [bytes-netbios-out <i>bytes-list-name</i>] [cost <i>cost</i>] [dest-mac <i>mac-address</i>] [dmac-output-list <i>access-list-number</i>] [dynamic] [host-netbios-out <i>host-list-name</i>] [inactivity <i>minutes</i>] [keepalive <i>seconds</i>] [lf <i>size</i>] [linger <i>minutes</i>] [lsap-output-list <i>list</i>] [no-llc <i>minutes</i>] [priority] [tcp-queue-max <i>size</i>] [timeout <i>seconds</i>]	Defines a TCP encapsulation remote peer.

Configuring an NCIA Server on the Local Router

Configuring an NCIA server on the local router enables the router to perform two roles:

- Establish TCP/NDLC sessions with clients to send and receive data.
- Use the standard interface (CLSI) to communicate with other software modules in the router, such as DLSw+, and DSPU, and act as the data intermediary between them and the NCIA clients.

To configure an NCIA server, use the following command in global configuration mode:

Command	Purpose
<pre>Router(config)# ncia server server-number server-ip-address server-virtual-mac-address virtual-mac-address virtual-mac-range [inbound-only] [keepalive seconds] [tcp_keepalive minutes]</pre>	Configures the NCIA server.

Configuring NCIA Server Session with DSPU

In the network configuration shown in Figure 206, the NCIA server uses DSPU to connect its clients to the FEP through a remote router. Figure 207 shows a logical view of the NCIA server session with RSRB/DLSw+ and DSPU.

Figure 206 NCIA Server Session with DSPU

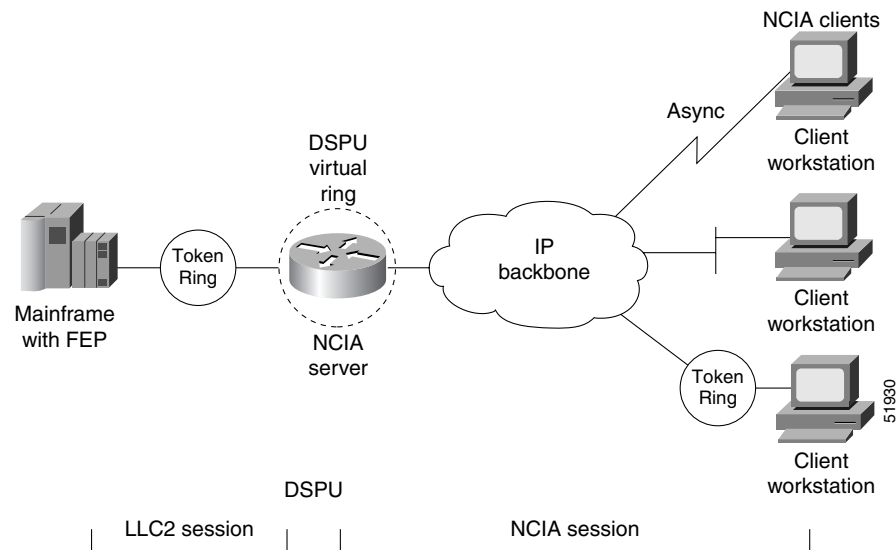
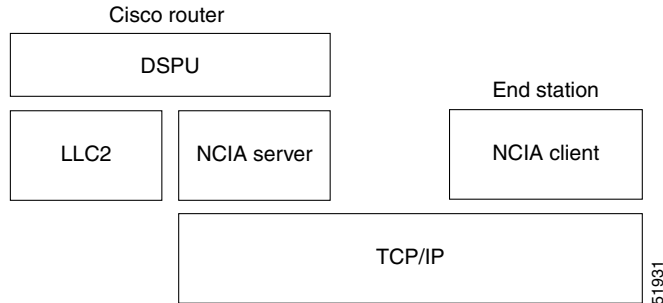

Figure 207 Logical View of NCIA Server with DSPU



DSPU Configuration Task List

To configure an NCIA server session connected to a remote router using DSPU, perform the tasks in the following sections:

- [Defining a DSPU Upstream Host, page 480](#)
- [Explicitly Defining DSPU, page 480](#)
- [Defining Dedicated LU, page 481](#)
- [Configuring the NCIA Server as the Underlying Transport Mechanism, page 481](#)

For a configuration example, see the “NCIA Server Session with DSPU Example” section on page 487.

Defining a DSPU Upstream Host

To define a DSPU host over Token Ring, Ethernet, Fiber Distributed Data Interface (FDDI), RSRB, or virtual data link control (VDLC) connections, use the following command in global configuration mode:

Command	Purpose
<pre>Router(config)# dspu host host-name xid-snd xid rmac remote-mac [rsap remote-sap] [lsap local-sap] [interface slot/port] [window window-size] [maxiframe max-iframe] [retries retry-count] [retry-timeout retry-timeout] [focalpoint]</pre>	Defines a DSPU host over Token Ring, Ethernet, FDDI, RSRB, or VDLC connections.

Explicitly Defining DSPU

To explicitly define a DSPU over Token Ring, Ethernet, FDDI, RSRB, VDLC, or NCIA connections, use the following command in global configuration mode:

Command	Purpose
<pre>Router(config)# dspu pu pu-name [rmac remote-mac] [rsap remote-sap] [lsap local-sap] [xid-rcv xid] [interface slot/port] [window window-size] [maxiframe max-iframe] [retries retry-count] [retry-timeout retry-timeout]</pre>	Explicitly defines a DSPU over Token Ring, Ethernet, FDDI, RSRB, VDLC, or NCIA connections.

Defining Dedicated LU

To define a dedicated logical unit (LU) or a range of dedicated LUs for an upstream host and DSPU, use the following command in global configuration mode:

Command	Purpose
Router(config)# dspu lu <i>lu-start</i> [<i>lu-end</i>] { host <i>host-name</i> <i>host-lu-start</i> pool <i>pool-name</i> } [pu <i>pu-name</i>]	Defines a dedicated LU or a range of dedicated LUs for a DSPU.

Configuring the NCIA Server as the Underlying Transport Mechanism

To configure the NCIA server as the underlying transport mechanism, use the following command in global configuration mode:

Command	Purpose
Router(config)# dspu ncia [<i>server-number</i>]	Configures the NCIA server as the underlying transport mechanism.

To enable a local service access point (SAP) on the NCIA server for use by DSPUs, use the following command in global configuration mode:

Command	Purpose
Router(config)# dspu ncia enable-pu [lsap <i>local-sap</i>]	Enables local SAP for DSPUs.

Configuring NCIA Server Session with RSRB

The network configuration shown in [Figure 208](#) includes NCIA clients that connect to a FEP on a Token Ring through a remote router. [Figure 209](#) shows a logical view of the NCIA Server session with RSRB (to a remote Token Ring). Because DLSw+ is the latest technology provided by Cisco, Cisco does not encourage using the NCIA Server feature with RSRB. If the router on the host side is running DLSw+, then RSRB should not be used. Support for the NCIA Server feature with RSRB is provided to encourage RSRB users to migrate to DLSw+.

Figure 208 NCIA Server Session with RSRB

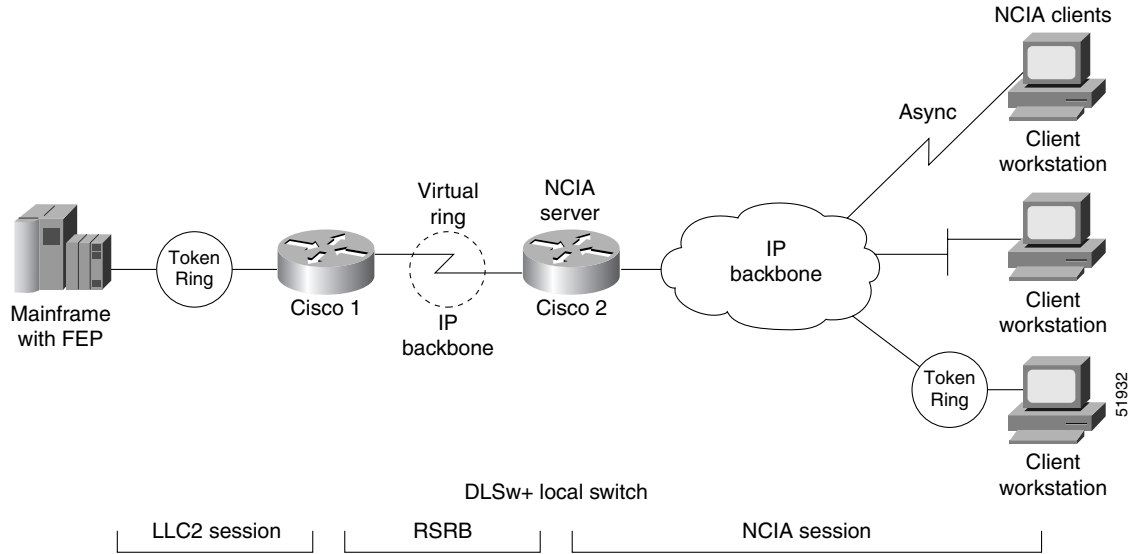
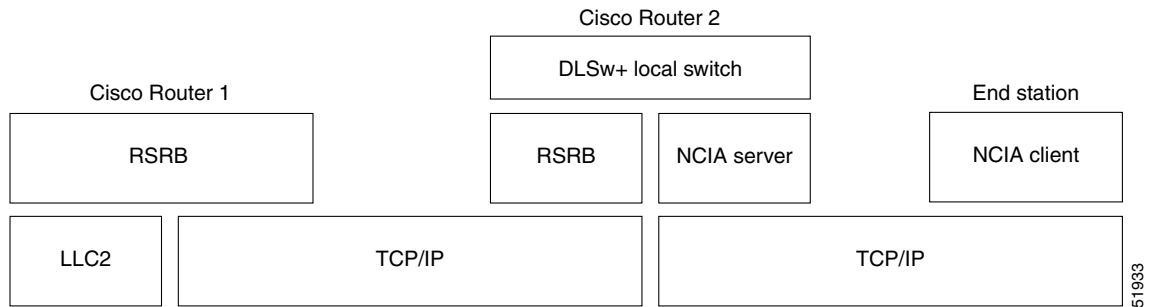

Figure 209 Logical View of NCIA Server Session with RSRB (Remote Token Ring)



RSRB Configuration Task List

To configure an NCIA server session connected to a remote Token Ring using RSRB, perform the tasks in the following sections:

- [Defining a Source-Bridge Ring Group for DLSw+ and RSRB, page 483](#)
- [Identifying the Remote Peer \(TCP Connection\), page 483](#)
- [Defining a DLSw+ Local Peer for the Local Router, page 483](#)
- [Configuring an NCIA Server on the Router, page 484](#)
- [Configuring an RSRB Ring for the NCIA Server on the Local Router, page 484](#)

For a configuration example, see the “NCIA Server Session with DLSw+ Example” section on page 486.

Defining a Source-Bridge Ring Group for DLSw+ and RSRB

The source-bridge virtual ring can be shared between DLSw+ and SRB/RSRB. In DLSw+, the source-bridge ring group specifies the virtual ring that will appear to be the last ring in the RIF. Because RIFs are terminated at the router, the ring group numbers specified in commands to set up DLSw+ peers can be different. The ring group numbers can be the same for management simplicity, but they do not have to be.

To define a source-bridge ring group for DLSw+, use the following command in global configuration mode:

Command	Purpose
Router(config)# source-bridge ring-group <i>ring-group</i> [<i>virtual-mac-address</i>]	Defines a ring group.

Identifying the Remote Peer (TCP Connection)

In our implementation, whenever you connect Token Rings using non-Token Ring media, you must treat that non-Token Ring media as a virtual ring by assigning it to a ring group. Every router with which you want to exchange Token Ring traffic must be a member of this same ring group. For more information about defining a ring group, see the “Define a Ring Group in SRB Context” section of the “Configuring Source-Route Bridging” chapter of this document.

To identify the remote peers, use the following command in global configuration mode:

Command	Purpose
Router(config)# source-bridge remote-peer <i>ring-group</i> tcp <i>ip-address</i> [<i>lf size</i>] [tcp-receive-window <i>wsize</i>] [local-ack] [priority]	Identifies the IP address of a peer in the ring group with which to exchange source-bridge traffic using TCP.

Specify one **source-bridge remote-peer** command for each peer router that is part of the virtual ring. Also specify one **source-bridge remote-peer** command to identify the IP address of the local router.

NCIA server supports only RSRB pass-through mode. Local acknowledgment is not supported.

Defining a DLSw+ Local Peer for the Local Router

Defining a DLSw+ local peer for the local router enables DLSw+. You specify all local DLSw+ parameters as part of the local peer definition. To define a local peer, use the following command in global configuration mode:

Command	Purpose
Router(config)# dlsw local-peer [peer-id <i>ip-address</i>] [group <i>group</i>] [border] [cost <i>cost</i>] [lf <i>size</i>] [keepalive <i>seconds</i>] [passive] [promiscuous] [biu-segment]	Defines the DLSw+ local peer.

Configuring an NCIA Server on the Router

Configuring an NCIA server on a router enables the router to perform two roles:

- Establish TCP/NDLC sessions with clients for the purpose of sending and receiving data.
- Use the standard interface (CLSI) to communicate with other software modules in the router, such as DLSw+, and DSPU, and to act as the data intermediary between them and the NCIA clients.

To configure an NCIA server, use the following command in global configuration mode:

Command	Purpose
Router(config)# ncia server <i>server-number</i> <i>server-ip-address server-virtual-mac-address</i> <i>virtual-mac-address virtual-mac-range</i> [inbound-only] [keepalive seconds] [tcp_keepalive <i>minutes</i>]	Configures the NCIA server.

Configuring an RSRB Ring for the NCIA Server on the Local Router

Configuring an RSRB ring to associate with the NCIA server on the local router provides the virtual ring that connects the DLSw ring within the local router and the target ring between the local router and the remote router.

To configure an RSRB ring for the NCIA server on the local router, use the following command in global configuration mode:

Command	Purpose
Router(config)# ncia rsrb <i>virtual-ring</i> <i>local-bridge local-ring ncia-bridge ncia-ring</i> <i>virtual-mac-address</i>	Defines the NCIA/RSRB interface.

Monitoring and Maintaining an NCIA Server Network

You can monitor and maintain the operation of an NCIA server network. To display information about the state of the NCIA server feature and perform maintenance tasks, use the following commands in EXEC mode:

Command	Purpose
Router# clear ncia circuit [<i>id-number</i>]	Drops an NCIA circuit.
Router# clear ncia client [<i>ip-address</i>]	Terminates an NCIA client connection.
Router# clear ncia client registered [<i>ip-address</i>]	Terminates the active connection to the specified client and release all control blocks of the registered client.
Router# ncia start	Restarts an NCIA server.
Router# ncia stop	Stops an NCIA server.
Router# show ncia circuits [<i>id-number</i>]	Shows the status of an NCIA circuit.
Router# show ncia client [sap-list] [<i>ip-address</i>]	Shows the status of the NCIA client.
Router# show ncia server [<i>server-number</i>]	Shows the status of the NCIA server.

NCIA Server Configuration Examples

The following sections provide NCIA server configuration examples:

- [NCIA Server Session to Local Token Ring Using DLSw+ Local Switch Example, page 485](#)
- [NCIA Server Session with DLSw+ Example, page 486](#)
- [NCIA Server Session with DSPU Example, page 487](#)
- [NCIA Server Session with RSRB Example, page 488](#)

NCIA Server Session to Local Token Ring Using DLSw+ Local Switch Example

Figure 210 illustrates the use of DLSw+ local peer with an NCIA server session to a local Token Ring.

Figure 210 NCIA Server Session to Local Token Ring Using DLSw+ Local Switch

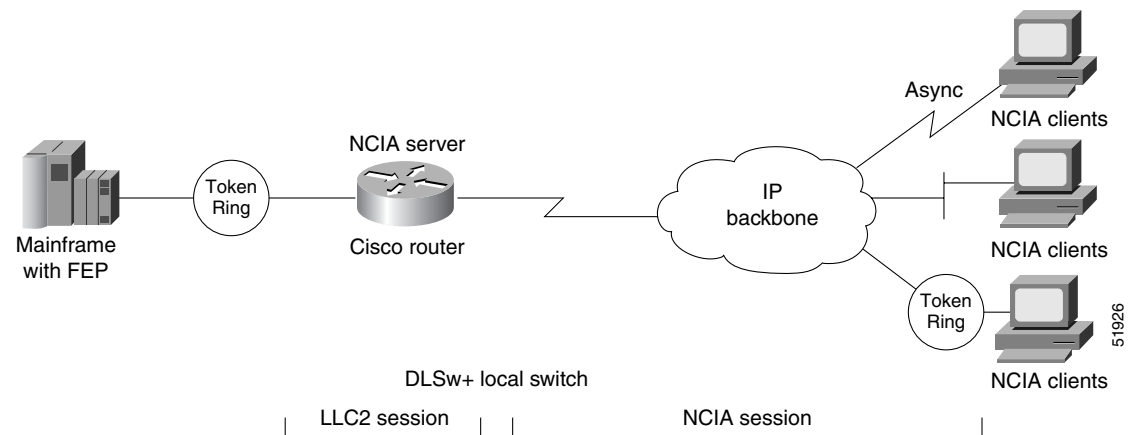

The following is a configuration for the network example shown in Figure 210:

```
source-bridge ring-group 44
dlsw local-peer
ncia server 1 10.2.20.4 4000.3174.0001 4000.0000.0001 128
!
interface token ring 0
 ring-speed 16
 source-bridge 21 3 44
```

NCIA Server Session with DLSw+ Example

Figure 211 illustrates the use of DLSw+ with an NCIA server session.

Figure 211 NCIA Server Session with DLSw+

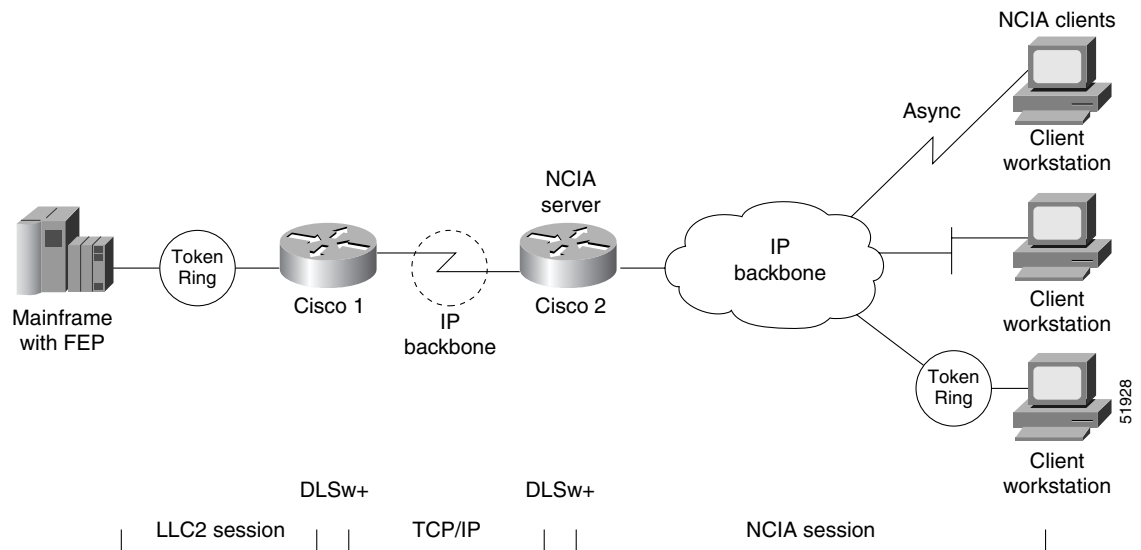

The following is a configuration for the network example shown in Figure 211:

```
source-bridge ring-group 44
dlsw local-peer peer-id 10.2.20.4
dlsw remote-peer 0 tcp 10.2.20.3
ncia server 1 10.2.20.4 4000.3174.0001 4000.0000.0001 128
```

NCIA Server Session with DSPU Example

Figure 212 illustrates an NCIA server session with RSRB/DLSw+ and DSPU.

Figure 212 NCIA Server Session with RSRB/DLSw+ and DSPU

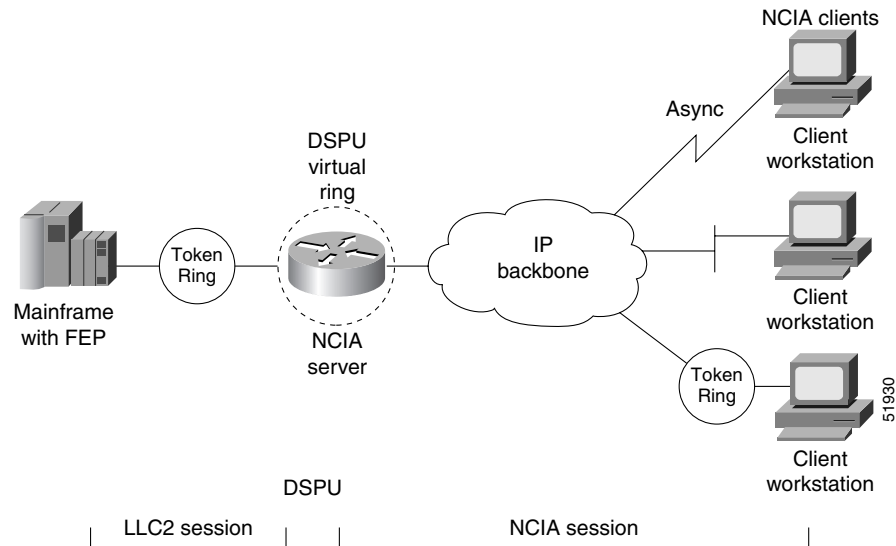

The following is a configuration for the network example shown in Figure 212:

```
ncia server 1 10.2.20.4 4000.3745.0001 4000.0000.0001 128
!
dspu ncia 1
dspu ncia enable-pu lsap 8
!
dspu host HOST-9370 xid-snd 11100001 rmac 4000.1060.1000 rsap 4 lsap 4
!
dspu pu CISCOPU-A xid-rcv 01700001
dspu lu 2 6 host HOST-9370 2
!
interface TokenRing 0
 ring-speed 16
 llc2 xid-retry-time 0
 dspu enable-host lsap 4
 dspu start HOST-9370
```

NCIA Server Session with RSRB Example

Figure 213 illustrates the use of RSRB with an NCIA server session.

Figure 213 NCIA Server Session with RSRB

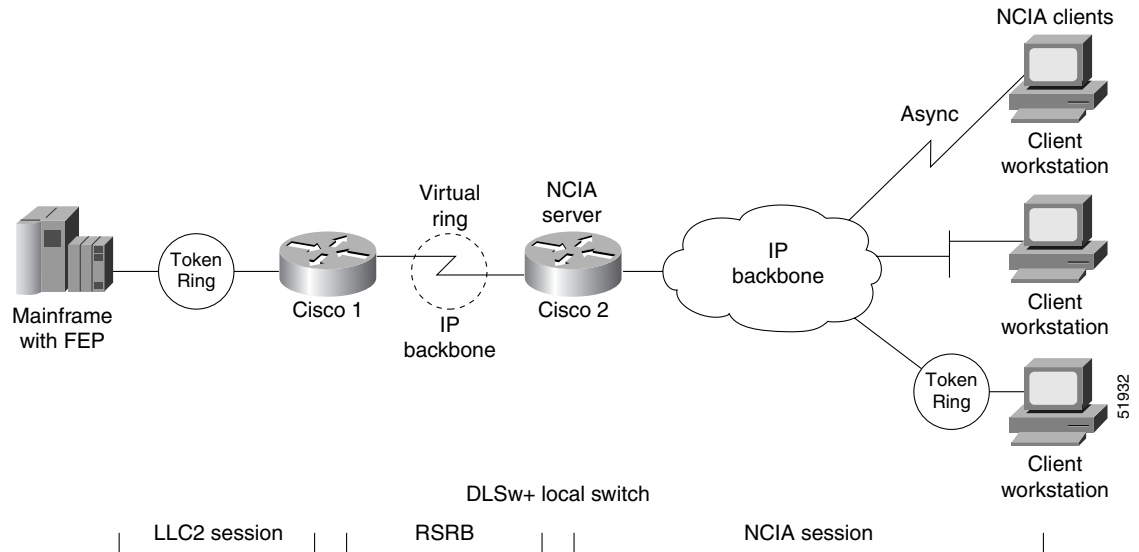

The following is a configuration for router Cisco 2 for the network example shown in Figure 213:

```
source-bridge ring-group 44
source-bridge ring-group 22
source-bridge remote-peer 22 tcp 10.2.20.3
source-bridge remote-peer 22 tcp 10.2.20.4
dlsw local-peer
ncia server 1 10.2.20.4 4000.3174.0001 4000.0000.0001 128
ncia rsrb 22 2 33 4 44 1111.1111.2222
```