



# Configuring AAL2 and AAL5 for the High Performance ATM Advanced Integration Module on the Cisco 2600 Series

## Feature History

Release	Modification
12.2(2)XA	The High Performance ATM Advanced Integration Module was introduced for the Cisco 2600 series.

This feature module describes the software functions of the High Performance ATM Advanced Integration Module (AIM) feature, which allows for ATM Adaptation Layer 2 (AAL2) and ATM Adaptation Layer 5 (AAL5) on the Cisco 2600 series. It includes information on the benefits of the new feature, supported platforms, related documents, and so on.

This document includes the following sections:

- [Feature Overview, page 1](#)
- [Supported Platforms, page 3](#)
- [Prerequisites, page 4](#)
- [Configuration Tasks, page 4](#)
- [Configuration Examples, page 26](#)
- [Command Reference, page 33](#)
- [Glossary, page 34](#)

## Feature Overview

The High Performance ATM AIM offers a cost-effective solution for supporting low-speed ATM WAN connections on the Cisco 2600 family of products. This feature enables the Cisco 2600 series to carry voice and data traffic over ATM networks using AAL2 and AAL5 without a dedicated ATM network module. AAL2 and AAL5 are the most bandwidth-efficient standards-based trunking methods for transporting compressed voice, voice-band data, circuit-mode data, and frame-mode data over ATM infrastructures. This feature provides a cost-effective, low-density ATM T1 or E1 solution for the Cisco 2600 series.

The High Performance ATM AIM helps service providers take advantage of the inherent quality of service (QoS) features of ATM multiservice applications. Transparent LAN services allow for the connection to separate sites at native LAN speeds, without requiring that the end user be familiar with ATM protocols. Frame Relay network expansion allows enterprise customers to take advantage of ATM's faster transmission speeds by leveraging core ATM switches linked to Frame Relay switches at the edge.

The High Performance ATM AIM is installed into an internal AIM slot. All Cisco 2600 routers support one internal AIM slot that connects to both the Cisco 2600's main system bus and a secondary time-division multiplexing (TDM) bus running between the WAN interface card (WIC) slots and network module slot.

Cisco 2600 routers have two WIC slots. When a High Performance ATM AIM is installed in a Cisco 2600 series router that has one 2-port T1/E1 Multiflex Voice/WAN (VWIC) in a WIC slot, the AIM card allows the router to provide a maximum of two separate ATM WAN interfaces at a DS1 or E1 rate. With a second 2-port VWIC, four separate ATM WAN interfaces are available.

To provide voice over ATM, the Cisco 2600 must have voice port capabilities provided by a digital packet voice trunk network module with a T1/E1 Multiflex VWIC. When also equipped with a High Performance ATM AIM, the router terminates up to 60 voice calls over T1 or E1 using AAL2.

**Figure 1 Cisco 2600 Router with High Performance ATM AIM**

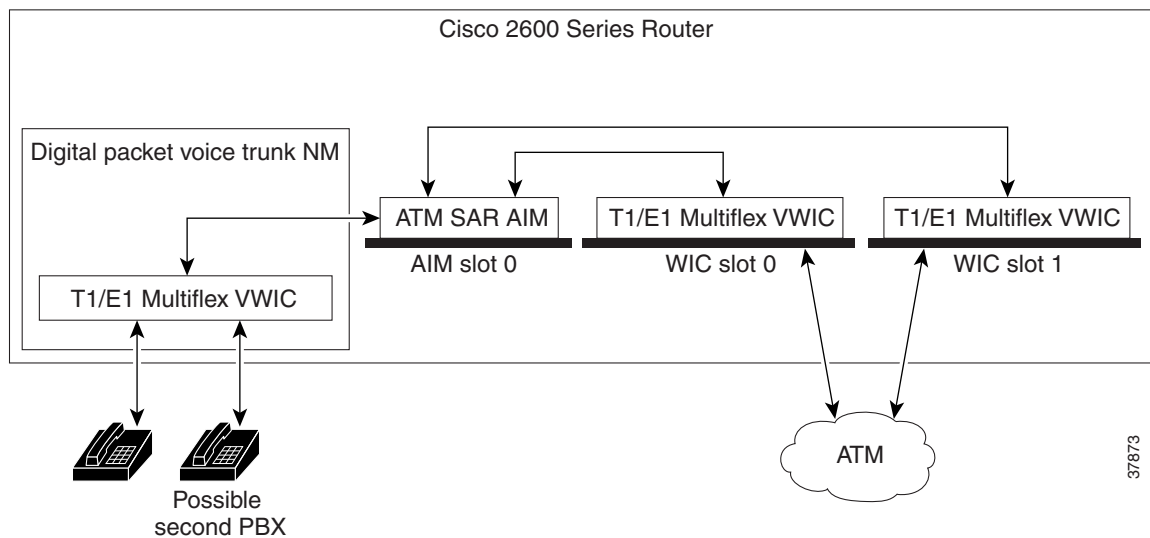

## Benefits

The High Performance ATM AIM provides the following improvements to the Cisco 2600 series' capabilities:

- Cisco 2600 series access to AAL2 and AAL5 capabilities across the WAN
- Cost-effective ATM WAN solution without purchasing an ATM WIC or additional network module
- Increased QoS capabilities
- Standards-based transport of voice over ATM
- Bandwidth-efficiency
- Robust architecture

- Signaling transparency
- Channel-associated signaling (CAS) and common channel signaling (CCS) support

## Restrictions

- The number of virtual path identifier (VPI) and virtual channel identifier (VCI) bits must equal 13 bits. The VPI default is five bits with a range of 0 to 31 bits; the VCI default is eight bits with a range of 1 to 256 bits.
- For variable bit rate real time VBR (RT) traffic shaping, the maximum burst size (MBS) is 255 cells.
- Subcell multiplexing is defaulted and not configurable.
- AAL2 supports a permanent virtual circuit (PVC); AAL5 supports PVC and a switched virtual circuit (SVC).
- If all of the 60 channels for transparent common-channel switching (TCCS) and transparent channel-associated signaling (TCAS) over AAL2 are configured, you cannot save the configuration into NVRAM. The configuration must be compressed to save it to the start up.
- The number of AAL2 VCs is limited to 16. Each VC supports up to 255 subchannels, and each subchannel can be used for voice port.

## Related Documents

- *Cisco IOS Voice, Video, and Fax Configuration Guide*, Release 12.2
- *Cisco IOS Voice, Video, and Fax Command Reference*, Release 12.2
- *Cisco IOS Wide-Area Networking Configuration Guide*, Release 12.2
- *Cisco IOS Wide-Area Networking Command Reference*, Release 12.2

## Supported Platforms

Cisco 2600 series

## Supported Standards, MIBs, and RFCs

### Standards

No new or modified standards are supported by this feature.

### MIBs

No new or modified MIBs are supported by this feature. The Chassis MIB has been modified to support the High Performance ATM AIM.

For descriptions of supported MIBs and how to use MIBs, see the Cisco web site on CCO at <http://www.cisco.com/public/sw-center/netmgmt/cmtk/mibs.shtml>.

### RFCs

No new or modified RFCs are supported by this feature.

## Prerequisites

Before you can configure your router to use the High Performance ATM AIM, complete these tasks:

- Ensure that you have 64 MB RAM and 16 MB Flash memory.
- For Voice over IP, ensure that your Cisco 2600 has a digital T1 or E1 packet voice trunk network module with a T1/E1 multiflex Voice/WAN Interface Card and the required number of digital signal processor (DSP) modules for your configuration. For more information about DSP modules, refer to *Connecting Voice Network Modules* in the *Cisco Network Modules Hardware Installation Guide*. Note that the Cisco 2600 series routers must have at least one 1- and 2-Port T1/E1 Multiflex Voice/WAN Interface Card slot.
- Establish a working ATM network. For more information about configuring ATM, refer to the *Cisco IOS Wide-Area Networking Configuration Guide*, Release 12.2.
- Complete your company's dial plan.
- Establish a working telephony based on your company's dial plan.
- Integrate your dial plan and telephony network into your existing ATM network topology.
- Contact your PBX vendor for instructions about how to reconfigure the appropriate PBX interfaces.

After you have analyzed your dial plan and decided how to integrate it into your existing ATM network, you are ready to configure your network devices to support the High Performance ATM AIM.

## Configuration Tasks

Software configuration for a Cisco 2600 series router with the High Performance ATM AIM feature involves:

- [Configuring ATM for AAL5, page 5](#)
  - [Configuring ATM Interfaces to Support Voice Traffic, page 5](#)
  - [Preparing to Configure Voice Dial Peers, page 7](#)
  - [Creating a Peer Configuration Table, page 7](#)
  - [Configuring Dial Peers, page 8](#)
  - [Configuring Cisco-Trunk Permanent Calls, page 15](#)
- [Configuring ATM for AAL2, page 16](#)
  - [Configuring ATM for AAL2 Voice, page 16](#)
  - [Configuring Call Admission Control for AAL2 Voice, page 20 \(optional\)](#)
  - [Configuring Subcell Multiplexing for AAL2 Voice, page 21](#)
  - [Configuring Dial Peers to Support AAL2, page 22](#)
  - [Configuring AAL2-Trunk Permanent Calls, page 24 \(optional\)](#)

## Configuring ATM for AAL5

**Note**

The Voice over ATM (VoATM) configuration must be performed on the routers on both sides of the voice connection.

Configuring the Cisco 2600 series to support VoATM for AAL5 encapsulation involves the following:

- [Configuring ATM Interfaces to Support Voice Traffic, page 5](#)
- [Preparing to Configure Voice Dial Peers, page 7](#)
- [Creating a Peer Configuration Table, page 7](#)
- [Configuring Dial Peers, page 8](#)
- [Configuring Cisco-Trunk Permanent Calls, page 15](#)

### Configuring ATM Interfaces to Support Voice Traffic

This section describes the preliminary ATM configuration tasks necessary to support VoATM.

**Note**

The VoATM configuration must be performed on the routers on both sides of the voice connection.

To configure the Cisco 2600 series to support VoATM, use the following commands beginning in global configuration mode:

	Command	Purpose
<b>Step 1</b>	Router(config)# <b>interface</b> ATMslot/port	Enters ATM interface configuration mode.
<b>Step 2</b>	Router(config-if)# <b>pvc</b> [name] vpi/vci	Creates an ATM PVC for voice traffic and enter virtual circuit configuration mode.
<b>Step 3</b>	Router(config-if-atm-pvc)# <b>encapsulation aal5mux voice</b>	Sets the encapsulation of the PVC to support voice traffic.
		 <b>Note</b> To configure a PVC to support data traffic, use aal5snap encapsulation.

Command	Purpose
<p><b>Step 4</b> Router(config-if-atm-pvc)# <b>vbr-rt</b> <i>peak-rate</i> <i>average-rate</i> [<i>burst</i>]</p>	<p>Configures the peak rate, average rate, and the burst cell size to perform traffic shaping between voice and data PVCs. By using the <b>vbr-rt</b> command, you can configure the variable bit-rate for real-time networks, such as for voice networks.</p> <p>Traffic shaping is necessary, so that the carrier does not discard the incoming calls from the router. To configure voice and data traffic shaping, you must configure the peak, average, and burst options for voice traffic. Configure the burst value if the PVC will be carrying bursty traffic. The peak, average, and burst values are needed so the PVC can effectively handle the bandwidth for the number of voice calls. To calculate the <i>minimum</i> peak, average, and burst values for the number of voice calls, use the following calculations:</p> <ul style="list-style-type: none"> <li>• Peak value: (2 x the maximum number of calls) x 16 kb The peak value equals the Peak Information Rate (PIR).</li> <li>• Average value: (1 x the maximum number of calls) x 16 kb The average value equals the Average Information Rate (AIR). This correlates to the carrier's sustained cell rate.</li> <li>• Burst value: (4 x the maximum number of calls) The burst value is the burst size in cells.</li> </ul> <p> <b>Note</b> When you configure data PVCs that will be traffic shaped with voice PVCs, use the <code>aal5snap</code> encapsulation and calculate the overhead as 1.13 times the voice rate.</p>
<p><b>Step 5</b> Router(config-if-atm-pvc)# <b>exit</b></p>	<p>Exits ATM virtual circuit configuration mode.</p> <p>The only commands in ATM virtual circuit configuration mode used for ATM voice PVCs are <b>encapsulation aal5mux voice</b>, <b>vbr-rt</b>, and <b>ilmi</b>.</p>
<p><b>Step 6</b> Router(config-if)# <b>pvc</b> [<i>name</i>] <i>vpi/vci</i></p>	<p>Creates an ATM PVC for data traffic and enters virtual circuit configuration mode.</p>
<p><b>Step 7</b> Router(config-if-atm-pvc)# <b>encapsulation aal5snap</b></p>	<p>Sets the encapsulation of the PVC to support ATM data traffic. In ATM PVC configuration mode, configure either the <b>ubr</b>, <b>ubr+</b>, or the <b>vbr-nrt</b> traffic shaping commands for the data PVC as appropriate.</p>

	Command	Purpose
Step 8	Router(config-if-atm-pvc)# <b>exit</b>	Exits ATM virtual circuit configuration mode. Repeat Steps 6 and 7 for each data PVC configured.
Step 9	Router(config-if)# <b>exit</b>	Exits interface configuration mode.
Step 10	Router(config)# <b>exit</b>	Exits global configuration mode.
Step 11	Router# <b>show atm vc</b>	Verifies the ATM PVC configuration.

**Note**

When verifying your ATM PVC connectivity, note that you cannot issue the **ping** command over a voice PVC because the command applies to data only. If you have data and voice PVCs set to the same destination, you can issue the **ping** command over the data PVC.

## Preparing to Configure Voice Dial Peers

After you have analyzed your dial plan and decided how to integrate it into your existing network, you are ready to configure your network devices to support VoATM. The actual configuration procedure depends on the topology of your voice network.

**Timesaver**

If possible, you might want to configure the ATM dial peers in a back-to-back configuration before separating them across the ATM network. Using a back-to-back configuration, you can test your VoATM and dial-peer configuration to see if you can successfully make a voice connection. Then, when you place both peers on the network, if you cannot make a voice connection, you can isolate the cause as a network problem.

## Creating a Peer Configuration Table

There is specific information relative to each dial peer that you must identify before you can configure VoATM. One way to do this is to create a peer configuration table.

Figure 2 shows a diagram of a small voice network in which Router 1, with ATM virtual circuit 20, connects a small sales branch office to the main office through Router 2. There are only two devices in the sales branch office that need to be established as dial peers: a basic telephone and a fax machine. Router 2, with an ATM virtual circuit of 40, is the primary gateway to the main office; as such, it needs to be connected to the company's PBX. There are three basic telephones connected to the PBX that need to be established as dial peers in the main office.

Table 1 shows the peer configuration table for the example illustrated in Figure 2.

Figure 2 Sample VoATM Network

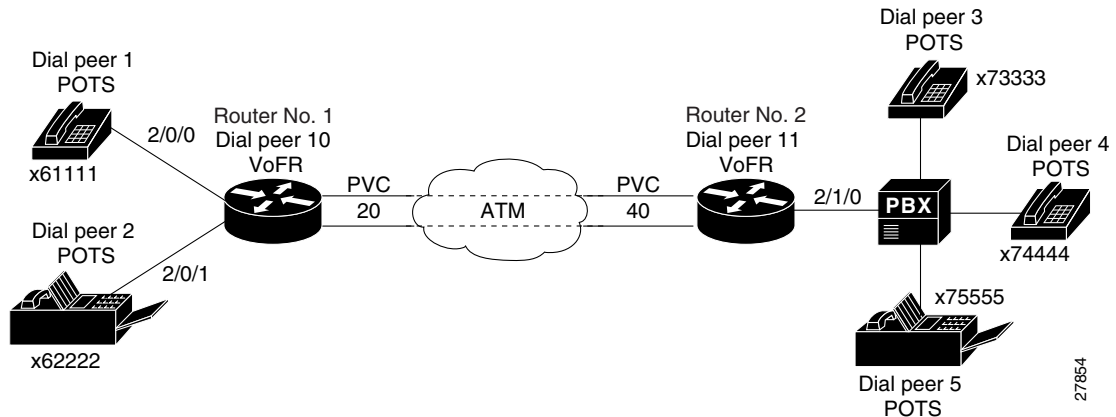

Table 1 Peer Configuration Table for Sample VoATM Network

Dial Peer	Extension	Prefix	Dest-Pattern	Type	Voice Port	Session Target
<b>Router 1</b>						
1	61111		+13101161111	POTS	2/0/0	
2	62222		+13101162222	POTS	2/0/1	
10			+1310117....	VoATM		S2 20
<b>Router 2</b>						
11			+1310116....	VoATM		S2 40
3	73333	7	+1310117....	POTS	2/1/0	
4	74444	7	+1310117....	POTS	2/1/0	
5	75555	7	+1310117....	POTS	2/1/0	

The dial plan shown in lists a simple dial-peer configuration table with no special configuration for how you forward or play out excess digits. For more information on other options for designing your dial plan and configuring your dial peers to connect with PBXs, see the *Cisco IOS Voice, Video, and Fax Configuration Guide*, Release 12.2.

## Configuring Dial Peers

Dial peers describe the entities to and from which a call leg is established. Dial-peer configuration tasks define the address or set of addresses serviced by that dial peer and the call parameters required to establish a call leg to and from that dial peer.

Two different kinds of dial peers are used for this procedure:

- Plain old telephone service (POTS)—Dial peer connecting a traditional telephony network. POTS dial peers point to a particular voice port on a voice-network device.
- VoATM—Dial peer connecting an ATM WAN backbone. VoATM dial peers point to specific voice-network devices.

POTS dial peers associate a telephone number with a particular voice port, so that incoming calls for that telephone number can be received. VoATM dial peers point to specific voice-network devices (by associating destination telephone numbers with a specific ATM virtual circuit), so that outgoing calls can be placed. Both POTS and VoATM dial peers are required if you want to send and receive calls using VoATM.

Establishing two-way communication with VoATM requires establishing a specific voice connection between two defined endpoints. As shown in [Figure 3](#), for outgoing calls (from the perspective of POTS dial peer 1), the POTS dial peer establishes the source (the originating telephone number and voice port) of the call. The VoATM dial peer establishes the destination by associating the destination phone number with a specific ATM virtual circuit.

**Figure 3** Calls from the Perspective of Router No. 1

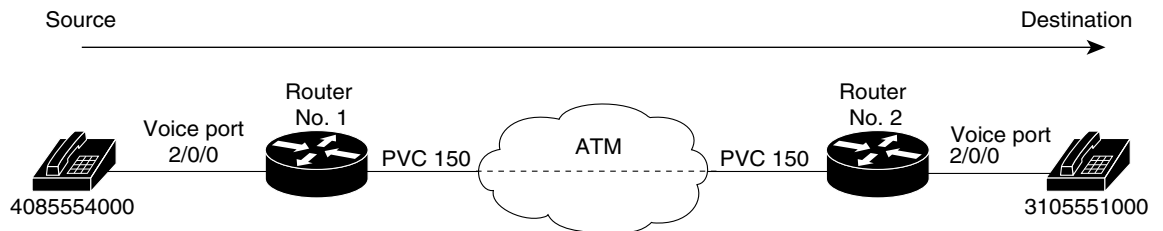

In the example, the destination pattern string 14085554000 maps to a U.S. phone number 555-4000, with the digit 1 plus the area code (408) preceding the number. When configuring the destination pattern, set the dial string to match the local dial conventions.

To complete the two-way communications loop, configure VoATM dial peer 2 as shown in [Figure 4](#).

**Figure 4** Calls from the Perspective of Router No. 2

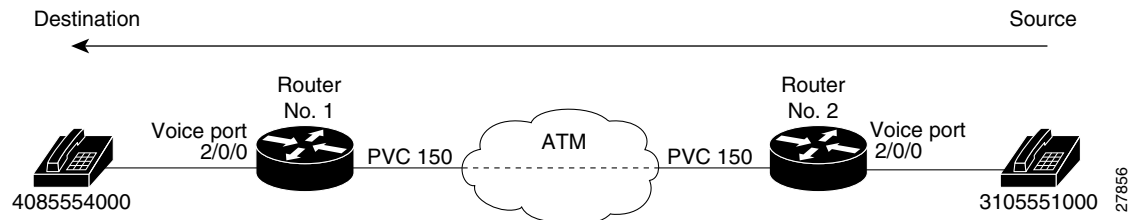

The only exception is when both POTS dial peers are connected to the same router, as shown in [Figure 5](#). In this circumstance, because both dial peers share the same destination IP address, you do not need to configure a VoATM dial peer.

**Figure 5** *Communication Between Dial Peers Sharing the Same Router*

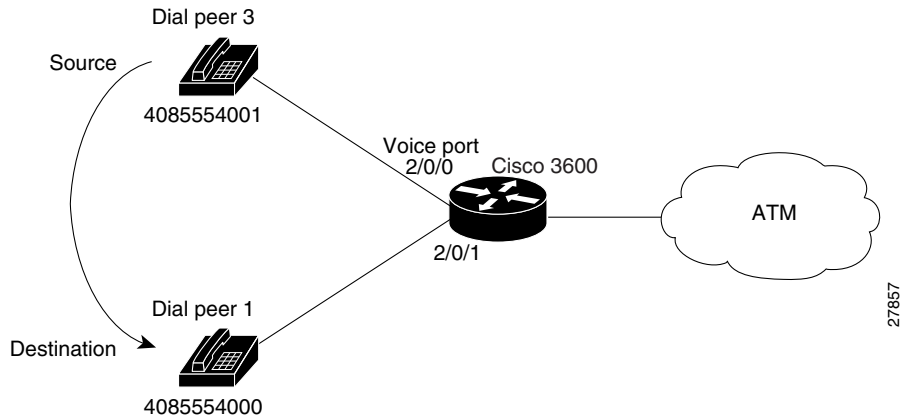

When configuring dial peers, you need to understand the relationship between the destination pattern and the session target. The destination pattern represents the pattern for the device at the voice connection endpoint, such as a telephone or a PBX. The session target represents the serial port on the peer router at the other end of the ATM connection. Figure 6 and Figure 7 show the relationship between the destination pattern and the session target, as seen from the perspective of both routers in a VoATM configuration.

**Figure 6** *Relationship Between the Destination Pattern and Session Target from the Perspective of Router No.1*

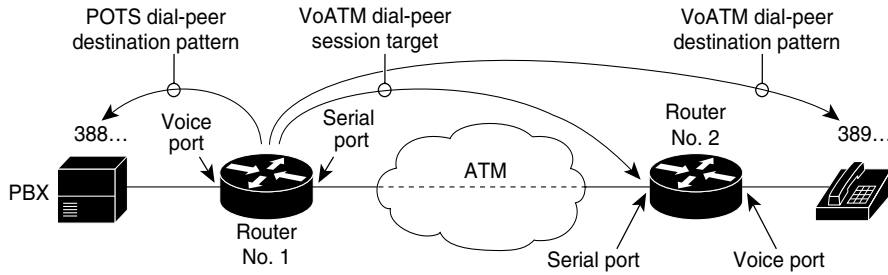

**Figure 7** *Relationship Between the Destination Pattern and Session Target from the Perspective of Router No.2*

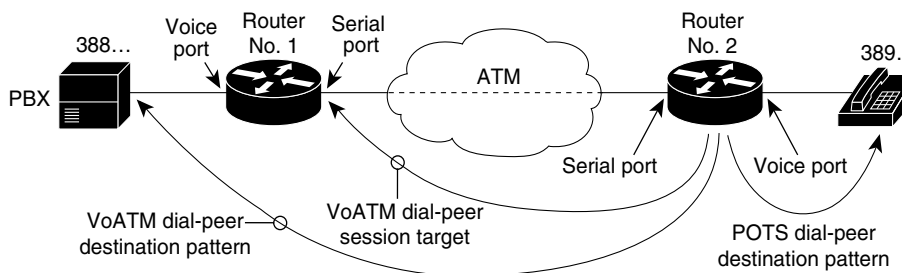

## Configuring POTS Dial Peers

To configure a POTS dial peer, identify the peer (by assigning it a unique tag number), define its telephone number, and associate it with a voice port through which calls can be established. Under most circumstances, the default values for the remaining dial-peer configuration commands are sufficient to establish connections.

To configure POTS peers, use the following commands beginning in global configuration mode:

	Command	Purpose
<b>Step 1</b>	Router(config)# <b>dial-peer voice</b> <i>tag</i> <b>pots</b>	<p>Defines a POTS dial peer and enter dial-peer configuration mode.</p> <p> <b>Note</b> All subsequent commands that you enter in dial-peer voice mode before you exit apply to this dial peer.</p> <p>The <i>tag</i> value identifies the dial peer and must be unique on the router. Do not duplicate a specific <i>tag</i> number.</p>
<b>Step 2</b>	Router(config-dial-peer)# <b>destination-pattern</b> <i>string</i>	<p>Configures the dial peer's destination pattern.</p> <p>The <i>string</i> is a series of digits that specify the E.164 or private dialing plan telephone number. Valid entries are the digits 0 through 9 and the letters A through D. You can enter the following special characters in the string:</p> <ul style="list-style-type: none"> <li>• The star character (*) and the pound sign (#) that appear on standard touch-tone dial pads can be used in any dial string. However, do not use these characters as leading characters in a string (for example, *650).</li> <li>• The period (.) can be entered any time, and is used as a wildcard character.</li> <li>• The comma (,) can be used only in prefixes, and is used to insert a one-second pause or a delay.</li> <li>• The timer (T) character can be used to configure variable-length dial plans.</li> </ul>
<b>Step 3</b>	Router(config-dial-peer)# <b>port</b> <i>slot/port/subunit</i>	<p>Associates this POTS dial peer with a specific logical dial interface. Enters the <i>slot/port/subunit</i> number of the voice port connected to the POTS dial peer.</p>
<b>Step 4</b>	Router(config-dial-peer)# <b>preference</b> <i>value</i>	<p>(Optional) Configures a preference for the POTS dial peer. The value is a number from 0 to 10 where the lower the number, the higher the preference. If POTS and voice-network (VoATM) peers are mixed in the same hunt group, POTS dial peers are searched first, even if a voice-network peer has a higher preference number.</p>

	Command	Purpose
<b>Step 5</b>	<pre>Router(config-dial-peer)# <b>forward-digits</b> {<i>num-digit</i>   <b>all</b>   <b>extra</b>} or Router(config-dialpeer)# <b>default forward-digits</b> or Router(config-dialpeer)# <b>no forward-digits</b></pre>	<p>(Optional) If using the forward-digits feature, configures the digit-forwarding method. The range for the number of digits forwarded (<i>num-digit</i>) is 0 to 32.</p> <p>In the default condition, dialed digits not matching the destination pattern are forwarded.</p> <p> <b>Note</b> The <b>no</b> state is not the <b>default</b> state.</p>
<b>Step 6</b>	<pre>Router(config-dial-peer)# <b>prefix</b> <i>string</i></pre>	<p>(Optional) If the forward digits feature was not configured in the last step, assigns the dialed digits prefix for the dial peer.</p>
<b>Step 7</b>	<pre>Router(config-dial-peer)# <b>exit</b></pre>	<p>Exits dial-peer configuration mode.</p>

To configure additional POTS dial peers, repeat the previous steps.

## Configuring VoATM Dial Peers

To configure a VoATM dial peer, you need to uniquely identify the peer by assigning it a unique tag number and define the outgoing serial port number and the virtual circuit number.

To configure VoATM dial peers, use the following commands beginning in global configuration mode:

	Command	Purpose
<b>Step 1</b>	<pre>Router(config)# <b>dial-peer voice</b> <i>tag</i> <b>voatm</b></pre>	<p>Defines a VoATM dial peer for VoATM and enter dial-peer configuration mode.</p> <p>The <i>tag</i> value identifies the dial peer and must be unique on the router. Do not duplicate a specific <i>tag</i> number.</p>
<b>Step 2</b>	<pre>Router(config-dial-peer)# <b>destination-pattern</b> <i>string</i></pre>	<p>Configures the dial peer's destination pattern. The same restrictions for the string listed in the POTS dial-peer configuration also apply to the VoATM destination pattern.</p>
<b>Step 3</b>	<pre>Router(config-dial-peer)# <b>session target</b> <b>ATM</b>/<i>y</i> <b>pvc</b> [<i>name</i>]   [<i>vpi</i>/<i>vci</i>]</pre>	<p>Configures the ATM session target for the dial peer.</p> <p>On the Cisco 2600, if you specify a <i>vpi/vci</i> combination, the valid values depend on the network module installed.</p> <p>If you have the Multiport T1/E1 ATM network module with IMA installed, the valid range for <i>vpi</i> is 0-15, and the valid range for <i>vci</i> is 1-255.</p> <p>If you have the OC3 ATM Network Module installed, the valid range for <i>vpi</i> is 0-15, and the valid range for <i>vci</i> is 1-1023.</p>

	Command	Purpose
Step 4	Router(config-dial-peer)# <b>preference</b> <i>value</i>	(Optional) Configures a preference for the VoATM dial peer. The value is a number from 0 to 10 where the lower the number, the higher the preference.
Step 5	Router(config-dial-peer)# <b>codec</b> <i>type</i> [ <b>bytes</b> <i>bytes</i> ]	Specifies the voice coder rate of speech and payload size for the dial peer. The default dial peer codec is <b>g729r8</b> .  Specifying the payload size by entering the <b>bytes</b> value is optional. Each codec type defaults to a different payload size if you do not specify a value. To obtain a list of the default payload sizes, enter the <b>codec</b> command and the <b>bytes</b> option followed by a question mark (?).
Step 6	Router(config-dial-peer)# <b>dtmf-relay</b>	(Optional) If the <b>codec</b> type is a low bit-rate codec such as <b>g729</b> or <b>g723</b> , specifies support for DTMF relay to improve end-to-end transport of DTMF tones. DTMF tones do not always propagate reliably with low bit-rate codecs.  DTMF relay is disabled by default.
Step 7	Router(config-dial-peer)# <b>signal-type</b> { <b>cas</b>   <b>cept</b>   <b>ext-signal</b>   <b>transparent</b> }	(Optional) Defines the type of the ABCD signaling packets that are generated by the voice port and sent to the data network. The signal type must be configured to the same setting at both ends of the permanent voice call.  Enter <b>cas</b> to support CAS. Enter <b>cept</b> to support the European CEPT standard (related to MEL CAS).  Enter <b>ext-signal</b> to indicate that ABCD signaling packets should not be sent, for configurations where the line signaling information is carried externally to the voice port.  Enter <b>transparent</b> (for digital T1/E1 interfaces) to read the ABCD signaling bits directly from the T1/E1 interface without interpretation and to pass them transparently to the data network. (This is also known as transparent FRF.11 signaling.)
Step 8	Router(config-dial-peer)# <b>no vad</b>	(Optional) Disables voice activity detection (VAD) on the dial peer. This command is enabled by default.
Step 9	Router(config-dial-peer)# <b>sequence-numbers</b>	(Optional) Enables the voice sequence number if required for your configuration. This command is disabled by default.
Step 10	Router(config-dial-peer)# <b>preference</b> <i>value</i>	(Optional) Configures a preference for the VoFR dial peer. The value is a number from 0 to 10 where the lower the number, the higher the preference in hunt groups.

	Command	Purpose
Step 11	Router(config-dial-peer) # <b>session protocol cisco-switched</b>	(Optional) Configures the session protocol to support Cisco-trunk permanent (private line) trunk calls.  The <b>cisco-switched</b> option is the default setting, and entering this command is not required.  If you do not want the dial peer to support Cisco-trunk permanent (private line) trunk calls, enter <b>no session protocol cisco-switched</b> .
Step 12	Router(config-dial-peer) # <b>fax rate {2400   4800   7200   9600   14400   disable   voice}</b>	(Optional) Configures the transmission speed (in bps) at which a fax will be sent to the dial peer.  The default is <b>voice</b> , which specifies the highest possible transmission speed allowed by the voice rate.
Step 13	Router(config-dial-peer) # <b>exit</b>	Exits dial-peer configuration mode.

To configure additional VoATM dial peers, repeat the previous steps.

### Configuring Dial Peer Hunting

After you have configured dial peers, you can configure how the router performs dial peer hunting functions. To configure the dial peer hunting behavior on the router, perform the following steps beginning in global configuration mode:

	Command	Purpose
Step 1	Router(config) # <b>dial-peer hunt hunt-order-number</b>	Specifies the hunt selection order for dial peers.
Step 2	Router(config) # <b>dial-peer terminator character</b>	(Optional) Designates a special character to be used as a terminator for variable length dialed numbers.

If using dial peer hunting, there may be situations when you want to disable dial-peer hunting on a specific dial peer. To disable dial-peer hunting on a dial peer, use the following commands beginning in global configuration mode:

	Command	Purpose
Step 1	Router(config) # <b>dial-peer voice tag {pots   voatm}</b>	Enters dial-peer configuration mode for the specified dial peer.
Step 2	Router(config-dial-peer) # <b>huntstop</b>	Disables dial-peer hunting on the dial peer. Once you enter this command, no further hunting is allowed if a call fails on the specified dial peer.
Step 3	Router(config-dial-peer) # <b>exit</b>	Exits dial-peer configuration mode.

To reenable dial-peer hunting on a dial peer, enter the **no huntstop** command.

## Configuring Cisco-Trunk Permanent Calls

To configure Cisco-trunk permanent calls on a Cisco 2600 series router for VoATM, use the following commands from global configuration mode:

	Command	Purpose
<b>Step 1</b>	For Cisco 2600 series analog voice ports: Router(config)# <b>voice-port</b> <i>slot/subunit/port</i>  For Cisco 2600 series digital voice ports: Router(config)# <b>voice-port</b> <i>slot/port:ds0-group</i>	Identifies the voice port you want to configure and enter voice-port configuration mode.
<b>Step 2</b>	Router(config-voiceport)# <b>connection trunk</b> <i>destination-string</i> [ <b>answer-mode</b> ]	Configures the trunk connection and specify the telephone number in the <i>destination-string</i> .  When configuring Cisco-trunk permanent calls, one side must be the call initiator (master) and the other side is normally the call answerer (slave). By default, the voice port operates in master mode. Enter the <b>answer-mode</b> keyword to specify that the voice port operates in slave mode.
<b>Step 3</b>	Router(config-voiceport)# <b>shutdown</b>	Shuts down the voice port.
<b>Step 4</b>	Router(config-voiceport)# <b>no shutdown</b>	Reactivates the voice port to enable the trunk connection to take effect.
<b>Step 5</b>	Router(config-voiceport)# <b>exit</b>	Exits voice-port configuration mode.



### Note

Every time you enter the **connection trunk** or **no connection trunk** command, you must toggle the voice port (by entering **shutdown**, then **no shutdown**) for the changes to take effect.

## Verifying the Voice Connection

Verify that the voice connection is working by doing the following:

- Pick up the handset on a telephone connected to the configuration and verify that you can get a dial tone.
- Make a call from the local telephone to a configured dial peer and verify that the call attempt is successful.

You can check the validity of your dial-peer and voice-port configuration by performing the following tasks:

- If you have relatively few dial peers configured, you can use the **show dial-peer voice** command to verify that the data configured is correct.
- To show the status of the voice ports, use the **show voice port** command.
- To show the call status for all voice ports, use the **show voice call** command.
- To show the current status of all DSP voice channels, use the **show voice dsp** command.

## Troubleshooting Tips

If you are having trouble connecting a call and you suspect the problem is associated with the dial-peer configuration, you can try to resolve the problem by performing the following tasks:

- Use the **show dial-peer voice** command on the local and remote routers to verify that the data is configured correctly on both.
- Use the **show interface** command to verify that the ATM interface is up.
- Make sure the voice ports, serial ports, and controllers are set to **no shutdown**.

## Configuring ATM for AAL2

To configure the High Performance ATM AIM for AAL2, complete the following tasks, as required:

- [Configuring ATM for AAL2 Voice, page 16](#)
- [Configuring Call Admission Control for AAL2 Voice, page 20](#) (optional)
- [Configuring Subcell Multiplexing for AAL2 Voice, page 21](#)
- [Configuring Dial Peers to Support AAL2, page 22](#)
- [Configuring AAL2-Trunk Permanent Calls, page 24](#) (optional)

**Note**

---

ATM defaults to Interim Local Management Interface (ILMI). If your carrier is using Local Management Interface (LMI), be sure to configure LMI support on the router.

---

## Configuring ATM for AAL2 Voice

This section describes the ATM configuration tasks necessary to support VoATM using AAL2. The commands and procedures in this section are specific to the Cisco 2600 series.

**Note**

---



If any DS0 groups (CAS groups), channel groups, or clear channels are configured on the T1/E1 controller at the slot/port, you must remove them before configuring VoATM. Because ATM uses all of the DS0 time slots on the controller, the ATM configuration cannot take place if any DS0s on the controller at the slot/port are used by other applications.

---

You must perform the VoATM configuration on the Cisco 2600 series at both ends of the ATM link.

To configure a Cisco 2600 series router to support VoATM on a T1/E1 trunk, complete the following steps, beginning in global configuration mode:

	Command	Purpose
Step 1	Router(config)# <b>network-clock-participate</b> slot slot	Enables the Cisco 2600 series router to receive clock signals from the High Performance ATM AIM by entering the slot number on the router.
Step 2	Router(config)# <b>network-clock-select</b> priority {t1   e1} slot/port	Names the 1- and 2-Port T1/E1 Multiflex Voice/WAN Interface Card as the resource that will provide timing for the network clock. Specify the selection priority for the clock.  Use the <b>no</b> form of this command to cancel the selection.
Step 3	Router(config)# <b>controller</b> {t1   e1} slot/port	Selects the T1 or E1 controller slot or port. On the Cisco 2600 router, ATM is supported by a slot and port.
Step 4	Router(config-controller)# <b>clock-source</b> line primary	Specifies the primary time-division multiplexing (TDM) source clock as T1 or E1. Use the <b>no</b> form of this command to change or remove the clocking source.
Step 5	Router(config-controller)# <b>mode atm aim 0</b>	Specify that the controller will support ATM encapsulation and create ATM AIM interface 0. The purpose of this command is to create an interface in preparation for Step 8.  When the controller is set to ATM mode, the following takes place: <ul style="list-style-type: none"> <li>• Controller framing is automatically set to Extended SuperFrame (ESF) on T1 and to CRC4 on E1.</li> <li>• The line code is automatically set to B8ZS on T1 and to HDB3 on E1.</li> </ul>
Step 6	Router(config-controller)# <b>no shutdown</b>	Makes sure that the controller is activated.
Step 7	Router(config-controller)# <b>exit</b>	Exits controller configuration mode.
Step 8	Router(config)# <b>interface</b> atmslot/port [subinterface-number [multipoint   point-to-point]]	Enters interface configuration mode to configure the High Performance ATM AIM slot and port, or an ATM subinterface.  For subinterfaces, the default is <b>multipoint</b> .   <b>Note</b> A subinterface is not generated by default; it must be created explicitly.

Command	Purpose
<b>Step 9</b> Router(config-if)# <b>pvc</b> [word] {vpi/vci   vci}	<p>Creates an ATM permanent virtual circuit (PVC) for voice traffic and enter ATM virtual circuit configuration mode. The defaults are as follows:</p> <p><i>vpi</i> = 0 to 31 bits  <i>vci</i> = 1 to 255 bits</p> <p><i>word</i> = optional PVC identifier (letters only); if you assign a PVC identifier, you can use it to specify this PVC when configuring network dial peers.</p> <p> <b>Note</b> The <b>ilmi</b> and <b>qsaal</b> options are not supported for AAL2.</p> <p>The <b>atm vc-per</b> command can be used to change the vci or vpi/vci bit range.</p>
<b>Step 10</b> Router(config-if-atm-vc) # <b>encapsulation aal2</b>	<p>Sets the encapsulation of the PVC to support AAL2 voice traffic. This automatically creates channel identifiers (CIDs) 1 through 255.</p> <p> <b>Note</b> The <b>shutdown controller</b> command shuts down the controller and ATM interface. To do a no shut, the <b>no shutdown</b> command must be used.</p>

Command	Purpose
<b>Step 11</b> Router(config-if-atm-vc)# <b>vbr-rt</b> <i>peak-rate</i> <i>average-rate</i> [ <i>burst</i> ]	Configures the PVC for variable-bit-rate real-time (voice) traffic. Guidelines for setting the peak rate, average rate, and burst size are as follows: <ul style="list-style-type: none"> <li>• Peak rate: If it does not exceed your carrier's allowable rate, set to the line rate (for example, 1500 kbps for T1-ATM).</li> <li>• Average rate: Calculate according to the maximum number of calls the PVC will carry times the bandwidth per call. The following formulas give you the average rate in kbps:               <ul style="list-style-type: none"> <li>G.711 with 40 or 80 byte sample size—max calls x 85</li> <li>G.726 with 40 or 80 byte sample size—max calls x 43</li> <li>G.729 with 30 byte sample size—max calls x 15</li> <li>G.729 with 20 byte sample size—max calls x 22</li> <li>G.729 with 10 byte sample size—max calls x 43</li> </ul>               If voice activity detection (VAD) is enabled, the bandwidth usage is reduced by as much as 12 percent with the maximum number of calls in progress. With fewer calls in progress, bandwidth savings are less.             </li> <li>• Burst size: Set the burst size as large as possible, and never less than the minimum burst size. Guidelines are as follows:               <ul style="list-style-type: none"> <li>The minimum burst size is 4 x the number of voice calls.</li> <li>The maximum burst size is 255 cells.</li> </ul> </li> </ul>
<b>Step 12</b> Router(config-if-atm-vc)# <b>oam-pvc</b> [ <b>manage</b> ] [ <i>frequency</i> ]	(Optional) Configures transmission of end-to-end F5 Operation and Maintenance (OAM) loopback cells on a PVC, optionally specify the number of seconds between loopback cells, and optionally enable OAM management of the connection.  The range for <i>frequency</i> is 0 to 600. The default is 10.

	Command	Purpose
Step 13	Router(config-if-atm-vc)# <b>oam retry</b> <i>up-count</i> <i>down-count</i> <i>retry-frequency</i>	<p>(Optional) Specifies OAM management parameters for verifying connectivity of a PVC connection. This command is supported only if OAM management is enabled.</p> <ul style="list-style-type: none"> <li>The <i>up-count</i> is the number of OAM loopback cell responses received to change the PVC connection to up. The range is 1 to 600; the default is 3.</li> <li>The <i>down-count</i> is the number of OAM loopback cell responses not received to change the PVC connection to down. The range is 1 to 600; the default is 5.</li> <li>The <i>retry-frequency</i> is the number of seconds between loopback cells sent to verify the down state of a PVC. The range is 1 to 1000; the default is 1.</li> </ul> <p> <b>Note</b> Enter the <b>oam retry</b> command only once, with all of the arguments in the order shown. The first number always specifies <i>up-count</i>; the second <i>down-count</i>, and the third <i>retry-frequency</i>.</p>
Step 14	Router(config-if-atm-vc)# <b>end</b>	Exits configuration mode.
Step 15	Router# <b>show atm vc</b>	Verifies the ATM PVC configuration.

**Note**

When verifying your ATM PVC connectivity, note that you cannot enter the **ping** command over a voice PVC because the command applies to data only. If you have data and voice PVCs set to the same destination, you can enter the **ping** command over the data PVC.

## Configuring Call Admission Control for AAL2 Voice

This section describes the configuration tasks necessary to configure call admission control (CAC) for AAL2 voice. The commands and procedures in this section are specific to the Cisco 2600 series. CAC is an optional feature.

You can configure a Cisco 2600 router as either a CAC master or a CAC slave. By default, a Cisco 2600 router is a CAC slave. You typically configure a CAC master at one end of an ATM trunk and a CAC slave at the opposite end. A Cisco 2600 series router configured as a master always performs CAC during fax/modem upspeed. A Cisco 2600 series router configured as a slave sends a request for CAC to the CAC master.

To configure a Cisco 2600 series router as a CAC master, complete the following steps beginning in global configuration mode:

	Command	Purpose
<b>Step 1</b>	Router(config)# <b>voice service voatm</b>	Enters voice-service configuration mode.
<b>Step 2</b>	Router(config-voice-service)# <b>session protocol aal2</b>	Enters voice-service-session configuration mode and specifies AAL2 trunking.
<b>Step 3</b>	Router(config-voice-service-session)# <b>cac master</b>	Configures this Cisco 2600 router as a CAC master. By default, a Cisco 2600 router is a CAC slave.
<b>Step 4</b>	Router(config-voice-service-session)# <b>end</b>	Exits voice-service-session configuration mode.

To return a Cisco 2600 series router to its default operation as a CAC slave, complete the following steps beginning in global configuration mode:

	Command	Purpose
<b>Step 1</b>	Router(config)# <b>voice service voatm</b>	Enters voice-service configuration mode.
<b>Step 2</b>	Router(config-voice-service)# <b>session protocol aal2</b>	Enters voice-service-session configuration mode and specifies AAL2 trunking.
<b>Step 3</b>	Router(config-voice-service-session)# <b>no cac master</b>	Configures this Cisco 2600 as a CAC slave.
<b>Step 4</b>	Router(config-voice-service-session)# <b>end</b>	Exits voice-service configuration mode.

## Configuring Subcell Multiplexing for AAL2 Voice

Subcell multiplexing is always on. It cannot be turned off.

## Configuring Dial Peers to Support AAL2

For more information on dial peers and dial-peer configuration, see the *Cisco IOS Voice, Video, and Fax Configuration Guide*, Release 12.2. To configure a network dial peer for VoATM, complete the following steps, beginning in global configuration mode:

	Command	Purpose
Step 1	Router(config)# <b>dial-peer voice tag voatm</b>	Defines a Voice-over-ATM dial peer for VoATM and enter dial-peer configuration mode.  The <i>tag</i> identifies the dial peer. Each <i>tag</i> on any one router must be a unique number.
Step 2	Router(config-dial-peer)# <b>destination-pattern string</b>	Configures the dial peer's destination pattern.  The <i>string</i> is a series of digits that specify the E.164 or private dialing plan telephone number. Valid entries are the digits 0 through 9 and the letters A through D. The following special characters can be entered in the string: <ul style="list-style-type: none"> <li>• The star (*) and the pound sign (#) can be used in a dial string, but not as leading characters (for example *650 is not permitted).</li> <li>• The period (.) can be entered as a wildcard digit. Network dial peers typically use wildcards to represent a range of destination telephone numbers (for example, 1408555.... for all numbers in area code 408 with the 555 prefix).</li> <li>• The comma (,) can be used only in prefixes, and is used to insert a 1-second pause.</li> <li>• The timer (T) character can be used to configure variable-length dial plans.</li> </ul>
Step 3	Router(config-dial-peer)# <b>session protocol aal2-trunk</b>	Configures the session protocol to support AAL2-trunk permanent (private line) trunk calls.
Step 4	Router(config-dial-peer)# <b>session target atmslot/port pvc {word   vpi/vci   vci} cid</b>	Configures the ATM session target for the dial peer. Be sure to specify <b>atmslot/port</b> as the interface for the PVC.  Use <i>word</i> to identify the PVC if a word name was assigned when the PVC was created in Step 9 of the <a href="#">“Configuring ATM for AAL2 Voice”</a> section on page 16.

	Command	Purpose
<b>Step 5</b>	<pre>Router(config-dial-peer)# <b>codec aal2 profile</b> {itut   custom} profile-number codec</pre>	<p>Specifies a codec profile for the DSP.</p> <p>Profile options are itut 1, itut 2, itut 7, custom 100, and custom 110.</p> <p>The default is itut 1 with codec G.711ulaw.</p> <p>See the command reference for the codec options available for each AAL2 profile.</p> <p> <b>Note</b> Use this command instead of the <b>codec (dial-peer)</b> command for AAL2 trunk applications.</p>
<b>Step 6</b>	<pre>Router(config-dial-peer)# <b>dtmf-relay</b></pre>	<p>(Optional) If the codec type is a low bit-rate codec such as G.729 or G.723, specifies support for Dual-Tone Multi-Frequency (DTMF) relay to improve end-to-end transport of DTMF tones. DTMF tones do not always propagate reliably with low bit-rate codecs.</p> <p>DTMF relay is disabled by default.</p>
<b>Step 7</b>	<pre>Router(config-dial-peer)# <b>signal-type</b> {ext-signal   transparent}</pre>	<p>(Optional) Defines the type of ABCD signaling packets that are generated by the voice port and sent over the ATM network. The signal type must be configured to the same setting at both ends of the PVC.</p> <p>Enter <b>ext-signal</b> for common channel signaling (CCS). ABCD signaling packets are not sent.</p> <p>Enter <b>transparent</b> for nonswitched trunks using channel-associated signaling (CAS). ABCD signaling bits are passed transparently to the ATM network.</p>
<b>Step 8</b>	<pre>Router(config-dial-peer)# <b>no vad</b></pre>	<p>(Optional) Disables voice activity detection (VAD) on the dial peer. VAD is enabled by default.</p>
<b>Step 9</b>	<pre>Router(config-dial-peer)# <b>exit</b></pre>	<p>Exits from the dial-peer configuration mode.</p>
<b>Step 10</b>	<p>To configure additional voice over ATM dial peers, repeat Step 1 through Step 9.</p>	

## Configuring AAL2-Trunk Permanent Calls

To configure AAL2-trunk permanent calls on a Cisco 2600 series router, complete the following commands, beginning in global configuration mode:

	Command	Purpose
Step 1	Router(config)# <b>voice-port</b> {slot/port}:ds0-group	For the Cisco 2600 series router's digital voice ports, enters voice port configuration mode.
Step 2	Router(config-voiceport)# <b>connection trunk</b> destination-string [ <b>answer-mode</b> ]	Configures the trunk connection, specifying the telephone number in the <i>destination-string</i> .  For AAL2-trunk permanent calls, the voice port at one end must be the call initiator (master) and the voice port at the other end is normally the call answerer (slave). By default, voice ports operate in master mode. Enter the <b>answer-mode</b> keyword to specify that a voice port should operate in slave mode.
Step 3	Router(config-voiceport)# <b>shutdown</b>	Shuts down the voice port.
Step 4	Router(config-voiceport)# <b>no shutdown</b>	Reactivates the voice port to enable the trunk connection to take effect.
Step 5	Router(config-voiceport)# <b>exit</b>	Exits voice-port configuration mode.



### Note

Every time you enter the **connection trunk** or **no connection trunk** command, or make any changes to VoATM dial peers, you must toggle the corresponding voice port (by entering **shutdown**, then **no shutdown**) to activate the changes.

## Verifying Your Configuration

You can check the validity of your dial-peer and voice-port configurations by performing the following tasks:

- If you have relatively few dial peers configured, you can use the **show dial-peer voice** command to verify that the data configured is correct.
- To show the status of the voice ports, use the **show voice port** command.
- To show the trunk status for all trunks, use the **show voice call summary** command.
- To show the current status of all DSP voice channels, use the **show voice dsp** command.
- Enter the **show atm pvc vpi/vci** command; this should display CID-level statistics.

## Troubleshooting Tips

If you are having trouble connecting a call and you suspect that the problem is associated with the dial-peer configuration, you can try to resolve the problem by performing the following tasks:

- Use the **show dial-peer voice** command on the local and remote routers to verify that the data is configured correctly on both.
- Use the **show interface** command to verify that the ATM interface is up.
- Make sure that the voice port and controller are set to **no shutdown**.

# Configuration Examples

The configuration examples in this section include the following:

- [Sample Configuration for VoATM at AAL5, page 26](#)
- [Sample Configuration for VoATM at AAL2, page 31](#)
  - [Cisco 2600 Configuration at End A, page 31](#)
  - [Cisco 2600 Configuration at End B, page 32](#)

**Note**

---

Hostnames and IP addresses in these examples are fictitious.

---

## Sample Configuration for VoATM at AAL5

```

version 12.2
service timestamps debug uptime
service timestamps log uptime
no service password-encryption
!
hostname aal5-test
!
!
!
no ip subnet-zero
no ip routing
ip wccp version 2
ip host keyer-ultra 172.31.20.62
!
!
!
dial-control-mib max-size 500
!
process-max-time 200
!
interface Ethernet0/0
 ip address 172.28.129.54 255.255.255.192
 ip helper-address 172.31.20.62
 no ip directed-broadcast
 no ip route-cache
 no ip mroute-cache
!
interface Serial0/0
 no ip address
 no ip directed-broadcast
 no ip route-cache
 no ip mroute-cache
 no fair-queue
!
interface Ethernet0/1
 no ip address
 no ip directed-broadcast
 no ip route-cache
 no ip mroute-cache
 shutdown
!

```

```
interface ATM1/0
 no ip address
 no ip directed-broadcast
 no ip route-cache
 no ip mroute-cache
 no atm ilmi-keepalive
 pvc 1/100
  vbr-rt 1000 500
  encapsulation aal5mux voice
 !
 no scrambling-payload
 impedance 120-ohm
 no fair-queue
 !
 !
interface ATM1/1
 no ip address
 no ip directed-broadcast
 no ip route-cache
 no ip mroute-cache
 no atm ilmi-keepalive
 pvc 2/100
  vbr-rt 1000 500
  encapsulation aal5mux voice
 !
 no scrambling-payload
 impedance 120-ohm
 no fair-queue
 !
 !
interface ATM1/1.1 point-to-point
 no ip directed-broadcast
 no ip route-cache
 no ip mroute-cache
 pvc 3/200
  vbr-rt 64 64 4
  encapsulation aal5mux voice
 !
 !
 !
interface ATM1/2
 no ip address
 no ip directed-broadcast
 no ip route-cache
 no ip mroute-cache
 shutdown
 no atm ilmi-keepalive
 no scrambling-payload
 impedance 120-ohm
 no fair-queue
 !
 !
interface ATM1/3
 no ip address
 no ip directed-broadcast
 no ip route-cache
 no ip mroute-cache
 shutdown
 no atm ilmi-keepalive
 no scrambling-payload
 impedance 120-ohm
 no fair-queue
 !
 !
```

```

interface ATM1/4
  no ip address
  no ip directed-broadcast
  no ip route-cache
  no ip mroute-cache
  shutdown
  no atm ilmi-keepalive
  no scrambling-payload
  impedance 120-ohm
  no fair-queue
!
interface ATM1/5
  no ip address
  no ip directed-broadcast
  no ip route-cache
  no ip mroute-cache
  shutdown
  no atm ilmi-keepalive
  no scrambling-payload
  impedance 120-ohm
  no fair-queue
!
interface ATM1/6
  no ip address
  no ip directed-broadcast
  no ip route-cache
  no ip mroute-cache
  shutdown
  no atm ilmi-keepalive
  no scrambling-payload
  impedance 120-ohm
  no fair-queue
!
interface ATM1/7
  no ip address
  no ip directed-broadcast
  no ip route-cache
  no ip mroute-cache
  shutdown
  no atm ilmi-keepalive
  no scrambling-payload
  impedance 120-ohm
  no fair-queue
!
!
interface ATM3/0
  no ip address
  no ip directed-broadcast
  no ip route-cache
  no ip mroute-cache
  map-group atm1
  atm clock INTERNAL
  pvc 2/200
    encapsulation aal5snap
  no atm auto-configuration
  no atm ilmi-keepalive
  no atm address-registration
  no atm ilmi-enable
  pvc voice 1/100
    vbr-rt 5000 2500
    encapsulation aal5mux voice
!
!
!
```

```
ip default-gateway 172.28.129.1
ip classless
ip route 172.30.20.62 255.255.255.255 172.28.129.1
no ip http server
!
!
map-list atm1
  ip 10.4.4.2 atm-vc 2 broadcast
!
map-class frame-relay fr1
!
map-class frame-relay voice
  no frame-relay adaptive-shaping
  frame-relay cir 128000
  frame-relay bc 128000
snmp-server engineID local 00000009020000107BC778C0
snmp-server community public RO
snmp-server community SNMPv2c view v2default RO
snmp-server community v2 view vldefault RO
snmp-server community config view vldefault RO
snmp-server community voice view vldefault RO
snmp-server packetize 4096
snmp-server enable traps snmp
snmp-server enable traps casa
snmp-server enable traps config
snmp-server enable traps voice poor-qov
snmp-server host 172.21.128.229 version 2c SNMPv2c config voice snmp
snmp-server host 172.21.128.242 version 2c public config voice snmp
snmp-server host 172.21.129.16 version 2c public tty frame-relay isdn hsrp
config entity envmon bgp rsvp rtr syslog stun sdlc dspu rsrp dlsd sdlc snmp
snmp-server host 172.21.129.164 version 2c public config voice snmp
!
line con 0
  exec-timeout 0 0
  transport input none
line aux 0
line vty 0 4
  session-timeout 10
  password apple
  login
!
voice-port 2/0/0
  input gain 5
  output attenuation 5
!
voice-port 2/0/1
  input gain 5
  output attenuation 5
!
voice-port 2/1/0
  input gain 5
  output attenuation 5
!
voice-port 2/1/1
  input gain 5
  output attenuation 5
!
dial-peer voice 2 pots
  destination-pattern 4001
!
dial-peer voice 8000 pots
  destination-pattern 84000
!
!
```

```
dial-peer voice 9000 pots
 destination-pattern 94000
!
dial-peer voice 9001 pots
 destination-pattern 94001
!
dial-peer voice 348 voatm
 destination-pattern 348....
 signal-type ext-signal
 session target ATM3/0 pvc 1/100
!
dial-peer voice 338 voatm
 destination-pattern 338....
 signal-type ext-signal
 session target ATM1/0 pvc 1/100
!
dial-peer voice 2222 voatm
 preference 1
 session target ATM1/0 pvc 1/100
!
dial-peer voice 9500 voatm
 destination-pattern 95...
 session target ATM3/0 pvc 1/100
!
dial-peer voice 8400 pots
 destination-pattern 84000
!
dial-peer voice 50000 voatm
 destination-pattern 5264000
 session target ATM3/0 pvc 1/100
!
dial-peer voice 10000 pots
 destination-pattern 5254000
 port 2/0/0
!
dial-peer voice 10001 pots
 destination-pattern 4000789
 port 2/1/0
!
num-exp 1 1234
num-exp 2 2234
num-exp 12 34567890
num-exp 55 66666
end
```

## Sample Configuration for VoATM at AAL2

The following is a sample configuration for VoATM on Cisco 2600 series routers at opposite ends of an AAL2 trunk:

### Cisco 2600 Configuration at End A

```
version 12.2
service timestamps debug uptime
service timestamps log uptime
no service password-encryption
!
hostname aal2-test1
!
!
!
!
!
network-clock base-rate 64k
ip subnet-zero
!
isdn voice-call-failure 0
!
!
voice-card 0
!
!
controller T1 0
mode atm
framing esf
linecode b8zs
!
controller T1 1
mode cas
framing esf
linecode b8zs
interface Ethernet0
ip address 10.7.78.1 255.255.0.0
!
interface Serial0
no ip address
!
interface Serial1
no ip address
shutdown
interface ATM0
no ip address
ip mroute-cache
no atm ilmi-keepalive
pvc 99/99
vbr-rt 1536 1536 254
encapsulation aal2
!
voice-port 1:1
no echo-cancel enable
timeouts wait-release 3
connection trunk 1001
!
!
```

```

dial-peer voice 1001 voatm
 destination-pattern 1001
 called-number 2001
 session protocol aal2-trunk
 session target ATM0 pvc 99/99 21
 dtmf-relay
 signal-type trans
 codec aal2-profile custom 100 g711ulaw
 no vad
!
dial-peer voice 201 pots
 destination-pattern 2001
 port 1:1
!end

```

## Cisco 2600 Configuration at End B

```

Current configuration:
!
version 12.2
service timestamps debug uptime
service timestamps log uptime
no service password-encryption
!
hostname aal2-faxtest2
!
!
!
network-clock base-rate 64k
ip subnet-zero
!
isdn voice-call-failure 0
!
!
voice-card 0
!
!
controller T1 0
 mode atm
 framing esf
 clock source internal
 linecode b8zs
!
!
controller T1 1
 mode cas
 framing esf
 linecode b8zs
 ds0-group 1 timeslots 1 type e&m-immediate-start
!
!
interface Ethernet0
 ip address 10.7.78.4 255.255.0.0
!
!
interface Serial0
 shutdown
!
interface Serial1
 no ip address
 shutdown
!

```

```
interface ATM0
 ip address 192.168.226.3 255.255.255.0
 ip mroute-cache
 no atm ilmi-keepalive
 pvc 99/99
  vbr-rt 1536 1536 254
  encapsulation aal2
 !
 !
 voice-port 1:1
 timeouts wait-release 3
  connection trunk 2001
 !
 dial-peer voice 201 pots
  destination-pattern 1001
 port 1:1
 !
 dial-peer voice 1001 voatm
  destination-pattern 2001
  called-number 1001
 session protocol aal2-trunk
  session target ATM0 pvc 99/99 21
 dtmf-relay
 signal-type trans
 codec aal2-profile custom 100 g711ulaw
 no vad
 line con 0
  exec-timeout 0 0
  transport input none
 line aux 0
 line 2 3
 line vty 0 4
  login
 !
end
```

## Command Reference

No new or modified commands are supported by this feature. All commands used with this feature are documented in the Cisco IOS Release 12.1 command reference publications.

# Glossary

**AAL**—ATM adaptation layer. Service-dependent sublayer of the data link layer. The AAL accepts data from different applications and presents it to the ATM layer in the form of 48-byte ATM payload segments. AALs consist of two sublayers: CS and SAR. AALs differ on the basis of the source-destination timing used, whether they use CBR or VBR, and whether they are used for connection-oriented or connectionless mode data transfer. At present, the four types of AAL recommended by the ITU-T are AAL1, AAL2, AAL3/4, and AAL5.

**AAL2**—ATM adaptation layer 2. One of four AALs recommended by the ITU-T. AAL2 is used for connection-oriented services that support a variable bit rate, such as some isochronous video and voice traffic.

**AAL5**—ATM adaptation layer 5. One of four AALs recommended by the ITU-T. AAL5 is used for connection-oriented services that support a variable bit rate, such as some isochronous video and voice traffic.

**AIM**—advanced integration module.

**ATM**—Asynchronous Transfer Mode. International standard for cell relay in which multiple service types (such as voice, video, or data) are conveyed in fixed-length (53-byte) cells. Fixed-length cells allow cell processing to occur in hardware, thereby reducing transit delays. ATM is designed to take advantage of high-speed transmission media such as E3, SONET, and T3.

**Call leg**—A logical connection between the router and either a telephony endpoint over a bearer channel or another endpoint using a session protocol.

**CAS**—channel associated signaling. A form of signaling that the circuit state is indicated by one or more bits of signaling status sent repetitively and associated with that specific circuit. CAS is used on a T1 line. With CAS, a signaling element is dedicated to each channel in the T1 frame. This type of signaling is sometimes called Robbed Bit Signaling (RBS) because a bit is taken out (or robbed) from the user's data stream to provide signaling information to and from the switch.

**codec**—coder-decoder. In Voice over IP, Voice over Frame Relay, and Voice over ATM, a DSP software algorithm used to compress/decompress speech or audio signals.

**CPCS**—common part convergence sublayer. One of the two sublayers of any AAL. The CPCS is service-independent and is further divided into the CS and the SAR sublayers. The CPCS is responsible for preparing data for transport across the ATM network, including the creation of the 48-byte payload cells that are passed to the ATM layer. See also AAL, ATM layer, CS, SAR, and SSCS.

**CS**—convergence sublayer. As an ATM term that covers the general procedures and functions that convert between ATM and non-ATM formats. It describes the functions of the upper half of the ATM Adaptation Layer (AAL) layer. It is also used to describe the conversion functions between non-ATM protocols such as frame relay or SMDS and ATM protocols above the AAL layer. One of the two sublayers of the AAL CPCS, responsible for padding and error checking. Protocol data units (PDUs) passed from the Service Specific Convergence Sublayer (SSCS) are appended with an 8-byte trailer (for error checking and other control information) and padded, if necessary, so that the length of the resulting PDU is divisible by 48. These PDUs are then passed to the SAR sublayer of the CPCS for further processing. See also AAL, CPCS, SAR, and SSCS.

**dial peer**—An addressable call endpoint. In Voice over ATM, there are two kinds of dial peers: POTS and VoATM.

**DLCI**—data-link connection identifier. Identifies the logical connection that is multiplexed into the physical channel. The DLCI value specifies a PVC or SVC in a Frame Relay network. In the basic Frame Relay specification, DLCIs are locally significant (connected devices might use different values to specify the same connection). In the LMI extended specification, DLCIs are globally significant (DLCIs

specify individual end devices). This is a number used by frame relay to distinguish one logical communications channel from another. Each frame relay frame carries a DLCI in its header to identify the channel over which the data are to be sent.

**DS0**—A 64-KB channel on an E1 or T1 WAN interface.

**DSP**—1. Digital signal processor. Many firmware functions of a NAS are performed by DSPs that are generally provisioned as banks of shared resources among all the DS0s. Typical DSP functions include: Data Modems, Voice CODECS, Fax Modems and CODECs, and low-level signaling (such as CAS/R2).

2. Domain specific part. Part of the ATM address format that is dependent on the format specified by the Authority and Format Identifier and consists of a High Order DSP (HO-DSP), an End System Identifier (ESI) and Selector (SEL). The ATM forum, instead of duplicating the OSI NSAP format exactly in the ATM address, combined the Routing Domain (RD) and AREA identifier into one field called the High Order DSP, which will be used to construct multilevel address hierarchies based on the application of a flexible prefix mask, similar in function to an IP subnet mask.

3. Digital signal processing. Signal transmission processing using digital techniques.

**DTMF**—dual tone multifrequency. Use of two simultaneous voice-band tones for dial (such as touch tone).

**E1**—Digital circuit with standardized characteristics that operates at 2.048 Mbps. This standard is widely used in Europe and in submarine cables. Uses two pairs of twisted pair wires. E1 is the European equivalent of a T1 line. The higher E1 clock rate (2.048 MHz) allows for 32 64-kbps time slots, including one time slot (typically time slot 0) for framing and one time slot (typically time slot 16) for D-channel information.

**E&M**—Stands for 2-wire or 4-wire interfaces with separate signaling paths (from “Ear and Mouth,” or “recEive and transMit”). E&M is a trunking arrangement generally used for two-way switch-to-switch or switch-to-network connections. Cisco’s analog E&M interface is an RJ-48 connector that allows connections to PBX trunk lines (tie lines). E&M connections are also available on E1 and T1 digital interfaces.).

**Frame Relay**—Industry standard, switched data link layer protocol that handles multiple virtual circuits using HDLC encapsulation between connected devices.

**FXO**—Foreign Exchange Office. An FXO interface connects to the PSTN’s central office and is the interface offered on a standard telephone. Cisco’s FXO interface is an RJ-11 connector that allows an analog connection to be directed at the PSTN’s central office. This interface is of value for off-premise extension applications.

**FXS**—Foreign Exchange Station. An FXS interface connects directly to a standard telephone and supplies ring, voltage, and dial tone. Cisco’s FXS interface is an RJ-11 connector that allows connections to basic telephone service equipment, keysets, and PBXs.

**GCRA**—generic cell rate algorithm. A reference model proposed by The ATM Forum for defining cell-rate conformance in terms of certain traffic parameters.

**hunting**—1. The automatic routing of calls to an idle circuit in a prearranged group when the circuit called is busy. 2. The movement of a call as it progresses through a group of lines. The call will try to connect to the first line of the group. If that line is busy, it will try the second line and then the third line, etc.

**ILMI**—interim link management interface. An ATM Forum-defined interim specification for network management functions between an end user and a public or private network and between a public network and a private network. ILMI specifies the use of the Simple Network Management Protocol (SNMP) and an ATM management information base (MIB) to provide network status and configuration information. Upon connection to the ATM network, the workstation will issue an ILMI registration process to bond it’s ESI address to the switches prefix. This accomplished through SNMP get requests.

**LAN**—local-area network. High-speed, low-error data network covering a relatively small geographic area (up to a few thousand meters). LANs connect workstations, peripherals, terminals, and other devices in a single building or other geographically limited area. LAN standards specify cabling and signaling at the physical and data link layers of the OSI model.

**LMI**—Local Management Interface. 1. A protocol with four different versions used to control the local interface from a routing device to the WAN Switch. Also used for configuration, flow control, and maintenance of the local connection. 2. In Frame Relay, an LMI is a packet containing sequence-number exchange between a DTI (router) and a switch. It is used by the switch to learn which DLCIs are defined and the current status of the DLCIs.

**maximum burst**—Specifies the largest burst of data above the insured rate that will be allowed temporarily on an ATM PVC, but will not be dropped at the edge by the traffic policing function, even if it exceeds the maximum rate. This amount of traffic will be allowed only temporarily; on average, the traffic source needs to be within the maximum rate. Specified in bytes or cells.

**MBS**—maximum burst size. In ATM signaling message, burst tolerance is conveyed through the MBS, which is coded as a number of cells. The burst tolerance together with the SCR and the GCRA determine the MBS that can be transmitted at the peak rate and still be in conformance with the GCRA.

**NM**—network module.

**OAM**—operations and maintenance. ATM Forum specification for cells used to monitor virtual circuits. OAM cells provide a virtual circuit-level loopback in which a router responds to the cells, demonstrating that the circuit is up, and the router is operational. A group of network management functions that provide network fault indication, performance information, system protection and data and diagnosis functions. Some switches have computers devoted to OAM. Northern Telecom, for example, uses a Sun Microsystems 3/80 B-4 processor in one of its central office switches.

**OSI**—Open Systems Interconnection. International standardization program created by ISO and ITU-T to develop standards for data networking that facilitate multivendor equipment interoperability.

**PBX**—private branch exchange. Privately owned central switching office. Digital or analog telephone switchboard located on the subscriber premises and used to connect private and public telephone networks.

**PLAR**—private line, automatic ringdown. This type of service results in a call attempt to some particular remote endpoint when the local extension is taken off-key.

**POTS**—plain old telephone service. Basic telephone service supplying standard single line telephones, telephone lines, and access to the PSTN.

**POTS dial peer**—Dial peer connected via a traditional telephony network. POTS peers point to a particular voice port on a voice network device.

**PSTN**—Public Switched Telephone Network. General term referring to the variety of telephone networks and services in place worldwide.

**PVC**—permanent virtual circuit. A circuit or channel through an ATM network provisioned by a carrier between two end points; used for dedicated long-term information transport between locations. Also virtual connection (VPC/ VCC) provisioned for indefinite use in an ATM network, established by the network management system (NMS). This is a link with static route defined in advance, usually by manual setup. Virtual circuit that is permanently established. PVCs save bandwidth associated with circuit establishment and tear down in situations where certain virtual circuits must exist all the time. Called a permanent virtual connection in ATM terminology. Compare with SVC.

**QoS**—quality of service. A term that refers to the set of ATM performance parameters that characterize the traffic over a given virtual connection (VC). QoS is a measurement on the delay and dependability that a particular connection will support. QoS is used by the Connection Admission Control (CAC) to allocate resources at connection time and by traffic management to ensure that the network performance objectives are met.

**SAR**—segmentation and reassembly. One of the two sublayers of the AAL CPCS, responsible for dividing (at the source) and reassembling (at the destination) the PDUs passed from the CS. The SAR sublayer takes the PDUs processed by the CS and, after dividing them into 48-byte pieces of payload data, passes them to the ATM layer for further processing. See also AAL, ATM layer, CPCS, CS, and SSCS.

**SCR**—sustainable cell rate. Parameter defined by the ATM forum for ATM traffic management. The SCR is an upper bound on the conforming average rate of an ATM connection over time scales that are long relative to those for which the packet cell ratio (PCR) is defined. Enforcement of this bound by the Usage Parameter Control (UPC) could allow the network to allocate sufficient resources, but less than those based on the PCR, and still ensure that the performance objectives (e.g., for Cell Loss Ratio) can be achieved. For Variable Bit Rate (VBR) connections, SCR determines the long-term average cell rate that can be transmitted. See VBR.

**SSCS**—service-specific convergence sublayer; an ATM term. One of the two components of the convergence sublayer (CS) of the AAL that is particular to the traffic service class to be converted. It is developed to support certain user applications such as LAN emulation, transport of high-quality video, and database management. SSCS, which is service dependent, offers assured data transmission. SSCS and LAN Emulation are needed to tie legacy addressing into ATM addressing and make the use of the ATM network transparent. SSCS and LAN Emulation make the most use of ATM addresses and Switch Virtual Circuit (SVC) services. The SSCS can be null as well, in classical IP over ATM or LAN emulation implementations. See also AAL, ATM layer, CPCS, CS, and SAR.

**SVC**—switched virtual circuit. Virtual circuit that is dynamically established on demand and is torn down when transmission is complete. SVCs are used in situations where data transmission is sporadic.

**T1**—Standard 1.544Mbps pulse code modulation (PCM) carrier system used to transport 24 telephone lines or various broadband services from one point to another. T1 is the standard carrier for the United States, Canada, Japan, and Singapore. All other countries use the E1 standard (30 channels on four wires). The T1 is a four-wire circuit, two wires for transmit and two wires for receive.

**TCAS**—transparent channel-associated signaling. See CAS.

**TCCS**—transparent common-channel switching. See CCS.

**TDM**—time division multiplexing. A technology that transmits multiple signals simultaneously over a single transmission path. Each lower-speed signal is time sliced into one high-speed transmission. For example, three incoming 1,000 bps signals (A, B and C) can be interleaved into one 3,000 bps signal (AABBCCAABBCCAABBCC). The receiving end reassembles the single stream back into its original signals. TDMs may be “bit-oriented”, “byte-oriented”, “frame-oriented” (Statistical Multiplexing), or “cell-oriented” (ATM/Fast Packet). TDM is the technology used in T-carrier service (DS0, DS1, etc.), which are the leased lines common in wide area networks (WANs).

**trunk**—Service that allows quasi-transparent connections between two PBXs, a PBX and a local extension, or some other combination of telephony interfaces with signaling passed transparently through the packet data network.

**upspeed**—An upspeed is a process by which the connection speed is dynamically increased for FAX and modem transmission.

**VBR**—variable bit rate. An asynchronous transfer mode (ATM) QoS service that guarantees bandwidth for the average cell rate of the application. It specifies both a sustained and peak cell rate. It guarantees a sustained cell rate as long as the peak cell rate is not required for a longer time than specified. VBR delivers the necessary bandwidth if traffic patterns are well understood. VBR is subdivided into a real time (RT) class and non-real time (NRT) class. VBR (RT) is used for connections in which there is a fixed timing relationship between samples. VBR (NRT) is used for connections in which there is no fixed timing relationship between samples, but that still need a guaranteed QoS. Compare with ABR (available bit rate), CBR, and UBR. See ATM Service Architecture, ATM classes of services.

**VBR-RT**—variable bit rate - real time. One of the service types for transmitting traffic that depends on timing information and control and which is characterized by the average and peak cell rates. It is suitable for carrying traffic such as packetized (compressed) video and audio. UNI 4.0 proposes a new (VBR-RT) was proposed in UNI 4.0. In addition to Peak Cell Rate (PCR), Sustained Cell Rate (SCR) and Maximum Burst Size (MBS), VBR-RT will also monitor Cell Delay Variation (CDV) and Maximum Cell Delay (MCD). This provide better performance over the VBR-RT.

**VCC**—virtual channel connection. As an ATM term, it is a concatenation of VCLs that extends between the points where the ATM service users access the ATM layer. The points at which the ATM cell payload is passed to, or received from, the users of the ATM Layer (i.e., a higher layer or ATM-entity) for processing signify the endpoints of a VCC. VCCs are unidirectional. ATM VCC can have one of two services types: 1) Connection-oriented-path established before data is sent. 2) Connectionless-data sent as datagrams. The connection-oriented path is typically used for AAL 1, 2, 3, 5 circuits. While the connectionless VCC is for AAL4, and is usually associated with Switched Multimegabit Data Service (SMDS). See also VCI, VCL, VPI, and AAL.

**VCI**—virtual channel identifier. The address or label of a VC (a virtual circuit). As an ATM term, it is a unique numerical tag as defined by a 16-bit field in the ATM cell header that identifies a virtual channel, over which the cell is to travel. The VCI, together with the VPI, is used to identify the next destination of a cell as it passes through a series of ATM switches on its way to its destination. ATM switches use the VPI/VCI fields to identify the next network VCL that a cell needs to transit on its way to its final destination. The function of the VCI is similar to that of the DLCI (Data Link Connection Identifier) in Frame Relay. Compare to DLCI. See also VCL and VPI.

**VCL**—virtual channel link. An ATM term. A means of unidirectional transport of ATM cells between the point where a VCI value is assigned and the point where that value is translated or removed. See also VCC.

**VoATM**—Voice over ATM. The ability to carry normal telephony-style voice over an ATM-based network with POTS-like functionality, reliability, and voice quality.

**VoATM dial peer**—Dial peer connected by an ATM network. VoATM peers point to specific VoATM devices.

**VPI**—virtual path identifier. An ATM term. Virtual Path Identifier is an 8-bit field in the ATM cell header that indicates the virtual path over which the cell should be routed. The VPI, together with the VCI, is used to identify the next destination of a cell as it passes through a series of ATM switches on its way to its destination. ATM switches use the VPI/VCI fields to identify the next VCL that a cell needs to transit on its way to its final destination. The function of the VPI is similar to that of the DLCI (data-link connection identifier) in Frame Relay. Compare with DLCI. See also VCI and VCL.

**VWIC**—voice WAN interface Card. See WAN.

**WAN**—wide-area network. Data communications network that serves users across a broad geographic area and often uses transmission devices provided by common carriers. Frame Relay, SMDS, and X.25 are examples of WANs.

**WIC**—wide-area network (WAN) interface card. The WIC can be placed in the network module slot.