



Configuring ISDN PRI and Other Signaling on E1 and T1 Lines

This chapter describes how to configure channelized E1 and channelized T1 for ISDN PRI and for two types of signaling to support analog calls over digital lines. The following main sections are provided:

- ISDN PRI Configuration Task List
- Configuring Robbed-Bit Signaling for Analog Calls over T1 Lines (Cisco AS5200)
- Configuring CAS for Analog Calls over E1 Lines (Cisco AS5200)
- Configuring Switched 56K Digital Dial-In over Channelized T1 and Robbed-Bit Signaling (Cisco AS5200 and Cisco AS5300)
- Configuring Switched 56K Services (Cisco AS5200 and Cisco AS5300)
- Configuring E1 R2 Signaling (Cisco AS5200, Cisco AS5300, and Cisco AS5800)
- Enabling International (Taiwan) R1 Modified Signaling (Cisco AS5200, Cisco AS5300, and Cisco AS5800)

In addition, this chapter describes how to run interface loopback diagnostics on channelized E1 and channelized T1 lines. For more information, see the “Configuring Switched 56K Digital Dial-In over Channelized T1 and Robbed-Bit Signaling” section later in this chapter.

For hardware technical descriptions, and for information about installing the controllers and interfaces, refer to the hardware installation and maintenance publication for your particular product.

For a complete description of the channelized E1/T1 commands in this chapter, see the *Cisco IOS Dial Services Command Reference* publication. To locate documentation of other commands that appear in this chapter, use the command reference master index or search online.

Signaling Overview

Channelized T1 and channelized E1 can be configured for ISDN PRI, synchronous serial, and asynchronous serial communications.

Channelized T1 and channelized E1 are supported by corresponding controllers. Each T1 or E1 controller has one physical network termination, but it can have many virtual interfaces, depending on the configuration.

In-Band and Out-of-Band Signaling

The terms *in-band* and *out-of-band* indicate whether various signals—which are used to set up, control, and terminate calls—travel in the same channel (or band) with voice calls or data made by the user, or whether those signals travel a separate channel (or band).

ISDN, which uses the D channel for signaling and the B channels for user data, fits into the out-of-band signaling category.

Robbed-bit signaling, which uses bits from specified frames in the user data channel for signaling, fits into the in-band signaling category.

Channel-associated signaling (CAS), which uses E1 time slot 16 (the D channel) for signaling, fits into the out-of-band signaling category.

Channelized E1 and T1 on the Cisco Access Servers

On a Cisco AS5000 series access servers, you can allocate the available channels for channelized E1 or T1 in the following ways:

- All channels can be configured to support ISDN PRI.
- If you are not running ISDN PRI, all channels can be configured to support robbed-bit signaling, which enables a Cisco AS5200 modem to receive and send analog calls.
- All channels can be configured in a single channel group. For configuration information about this leased line or nondial use, see the “Configuring Serial Interfaces” chapter in the *Cisco IOS Interface Configuration Guide*.
- Mix and match channels supporting ISDN PRI and channel grouping.
- Mix and match channels supporting ISDN PRI, robbed-bit signaling, and channel grouping across the same T1 line. For example, on the same channelized T1 line you can configure the **pri-group timeslots 1-10** command, **channel-group 11 timeslots 11-16** command, and **cas-group 17 timeslots 17-23 type e&m-fgb** command. This is a rare configuration because it requires you to align the correct range of time slots on both ends of the connection.

See the sections “PRI Groups and Channel Groups on the Same Channelized T1 Controller,” “Robbed-Bit Signaling Examples,” and the “ISDN CAS Examples” at the end of this chapter.

ISDN PRI Configuration Task List

This section describes tasks that are required to get ISDN PRI up and running. This section does not address routing issues, dialer configuration, and dial backup. For information about those topics, see the chapters in the “Dial-on-Demand Routing” part of this manual.

ISDN PRI is supported on the Cisco 7200 series and 7500 series routers using T1 or E1 versions of the Multichannel Interface Processor (MIP) card, on the Cisco 4000 series channelized E1/T1/PRI network processor module (NPM), and on the Cisco AS5200 access server.

Channelized T1 ISDN PRI offers 23 B channels and 1 D channel.

Channelized E1 ISDN PRI offers 30 B channels and 1 D channel. Channel 24 is the D channel for T1, and channel 16 is the D channel for E1.

Perform the tasks in the following sections to configure ISDN PRI:

- Requesting PRI Line and Switch Configuration from a Telco Service Provider (Required)
- Configuring Channelized E1 ISDN PRI (As Required)
- Configuring Channelized T1 ISDN PRI (As Required)
- Configuring the Serial Interface (Required)
- Configuring NSF Call-by-Call Support (Primary-4ESS Only)
- Configuring Multiple ISDN Switch Types (Optional)
- Configuring B Channel Outgoing Call Order (Optional)
- Performing Configuration Self-Tests (Optional)
- Configuring CAS (Optional)

See the section “Monitoring and Maintaining ISDN PRI Interfaces” later in this chapter for tips on maintaining the ISDN PRI interface. See the end of this chapter for the “ISDN PRI Examples” section.



Note

After the ISDN PRI interface and lines are operational, configure the D-channel interface for dial-on-demand routing (DDR). The DDR configuration specifies the packets that can trigger outgoing calls, specifies whether to place or receive calls, and provides the protocol, address, and phone number to use.

Requesting PRI Line and Switch Configuration from a Telco Service Provider

Before configuring ISDN PRI on your Cisco router, you need to order a correctly provisioned ISDN PRI line from your telecommunications service provider.

This process varies dramatically from provider to provider on a national and international basis. However, some general guidelines follow:

- Verify if the outgoing B channel calls are made in ascending or descending order. Cisco IOS default is descending order however, if the switch from the service providers is configured for outgoing calls made in ascending order, the router can be configured to match the switch configuration of the service provider.
- Ask for delivery of calling line identification. Providers sometimes call this CLI or automatic number identification (ANI).
- If the router will be attached to an ISDN bus (to which other ISDN devices might be attached), ask for point-to-multipoint service (subaddressing is required) and a voice-and-data line.

Table 16 provides a sample of the T1 configuration attributes you might request for a PRI switch.

Table 16 PRI Switch Configuration Attributes to Request

Attribute	Value
Line format	Extended Superframe Format (ESF)
Line coding	Binary 8-zero substitution (B8ZS)
Call type	23 incoming channels and 23 outgoing channels
Speed	64 kbps
Call-by-call capability	Enabled

Table 16 PRI Switch Configuration Attributes to Request (continued)

Attribute	Value
Channels	23 B + D
Trunk selection sequence	Either ascending order (from 1 to 23) or descending order (from 23 to 1)
B + D glare	Yield
Directory numbers	Only 1 directory number assigned by service provider
SPIDs required?	None

Configuring Channelized E1 ISDN PRI

To configure ISDN PRI on a channelized E1 controller, use the following commands beginning in global configuration mode:

	Command	Purpose
Step 1	<code>isdn switch-type switch-type</code>	Selects a service provider switch type that accommodates PRI. (Refer to Table 17 for a list of supported switch type keywords.)
Step 2	<code>controller e1 slot/port</code> or <code>controller e1 number</code>	Defines the controller location in the Cisco 7200 or Cisco 7500 series router by slot and port number. Defines the controller location in the Cisco 4000 series or the Cisco AS5200 universal access server by unit number. ¹
Step 3	<code>framing crc4</code>	Defines the framing characteristics as cyclic redundancy check 4 (CRC4).
Step 4	<code>linecode hdb3</code>	Defines the line code as high-density bipolar 3 (HDB3).
Step 5	<code>pri-group [timeslots range]</code>	Configures ISDN PRI.

1. Controller numbers range 0 through 2 on the Cisco 4000 series and 1 to 2 on the Cisco AS5200 access server.

If you do not specify the time slots, the specified controller is configured for 30 B channels and 1 D channel. The B channel numbers range 1 to 31; channel 16 is the D channel for E1. Corresponding serial interfaces numbers range 0 to 30. In commands, the D channel is **interface serial controller-number:15**. For example, **interface serial 0:15**.

Table 17 lists the keywords for the supported service provider switch types to be used in Step 1 above.

Table 17 ISDN Service Provider PRI Switch Types

Keywords by Area	Switch Type
none	No switch defined.

Table 17 ISDN Service Provider PRI Switch Types (continued)

Australia and Europe	
primary-net5	ISDN PRI switch type for Europe, New Zealand, Australia, and Asia (covers the Euro-ISDN E-DSS1 signaling system and is compliant with European Telecommunication Standards Institute or ETSI).
Japan	
primary-ntt	Japanese ISDN PRI switches.
North America	
primary-4ess	AT&T 4ESS switch type for the United States.
primary-5ess	AT&T 5ESS switch type for the United States.
primary-dms100	NT DMS-100 switch type for the United States.
primary-ni	National ISDN switch type.

**Note**

Cisco IOS Release 11.3 T introduced ISDN switch type changes. The command parser will still accept the following switch type keywords: **basic-nwnet3**, **vn2**, and **basic-net3**; however, when the NVRAM configuration is viewed, the **basic-net3** or **vn3** switch types are displayed respectively. For specific details about ISDN switch type changes, refer to the “National ISDN Switch Types for Basic Rate and Primary Rate Interfaces” document in Cisco IOS Release 11.3(3)T.

Configuring Channelized T1 ISDN PRI

To configure ISDN PRI on a channelized T1 controller, use the following commands beginning in global configuration mode:

	Command	Purpose
Step 1	<code>isdn switch-type switch-type</code>	Selects a service provider switch type that accommodates PRI. (Refer to Table 17 for a list of supported PRI switch type keywords.)
Step 2	<code>controller t1 slot/port</code> or <code>controller t1 number</code>	Specifies a T1 controller on a Cisco 7500. Specifies a T1 controller on a Cisco 4000. ¹
Step 3	<code>framing esf</code>	Defines the framing characteristics as Extended Superframe Format (ESF).

	Command	Purpose
Step 4	<code>linecode b8zs</code>	Defines the line code as binary 8 zero substitution (B8ZS).
Step 5	<code>pri-group [timeslots range]²</code>	Configures ISDN PRI. If you do not specify the time slots, the controller is configured for 23 B channels and 1 D channel.

1. Controller numbers range 0 through 2 on the Cisco 4000 series and 1 to 2 on the Cisco AS5200.
2. On channelized T1, time slots range 1 to 24. You can specify a range of time slots (for example, **pri-group timeslots 12-24**) if other time slots are used for non-PRI channel groups.

If you do not specify the time slots, the specified controller is configured for 24 B channels and 1 D channel. The B channel numbers range 1 to 24; channel 24 is the D channel for T1. Corresponding serial interfaces numbers range 0 to 23. In commands, the D channel is **interface serial controller-number:23**. For example, **interface serial 0:23**.

Configuring the Serial Interface

When you configure ISDN PRI on the channelized E1 or channelized T1 controller, in effect you create a serial interface that corresponds to the PRI group time slots. This interface is a logical entity associated with the specific controller. After you create the serial interface by configuring the controller, you must configure the D channel serial interface. The configuration applies to all the PRI B channels (time slots).

To configure the D channel serial interface, perform the tasks in the following sections:

- Specifying an IP Address for the Interface (Required)
- Configuring Encapsulation on ISDN PRI (Required)
- Configuring Network Addressing (Required)
- Overriding the Default TEI Value (Required)
- Configuring ISDN Calling Number Identification (Required)
- Configuring ISDN Voice Calls (Optional)
- Configuring Inclusion of the Sending Complete Information Element (Optional)

Specifying an IP Address for the Interface

To configure the D channel serial interface created for ISDN PRI, use the following commands beginning in global configuration mode:

	Command	Purpose
Step 1	<code>interface serial slot/port:23</code> <code>interface serial number:23</code> or <code>interface serial slot/port:15</code> <code>interface serial number:15</code>	Specifies D channel on the serial interface for channelized T1. Specifies D channel on the serial interface for channelized E1.
Step 2	<code>ip address ip-address</code>	Specifies an IP address for the interface.

When you configure the D channel, its configuration is applied to all the individual B channels.

Configuring Encapsulation on ISDN PRI

PPP encapsulation is configured for most ISDN communication. However, the router might require a different encapsulation for traffic sent over a Frame Relay or X.25 network, or the router might need to communicate with devices that require a different encapsulation protocol.

Configure encapsulation as described in one of the following sections:

- Configuring PPP Encapsulation
- Configuring Encapsulation for Frame Relay or X.25 Networks
- Configuring Encapsulation for Combinet Compatibility

In addition, the router can be configured for automatic detection of encapsulation type on incoming calls. To configure this feature, complete the tasks in the “Configuring Automatic Detection of Encapsulation Type of Incoming Calls” section.



Note

See the sections “Dynamic Multiple Encapsulations” and “Configuring Encapsulation on ISDN BRI” in the chapter “Setting Up Basic ISDN Service” for information about the Cisco Dynamic Multiple Encapsulations feature.

Configuring PPP Encapsulation

Each ISDN B channel is treated as a serial line and supports HDLC and PPP encapsulation. The default serial encapsulation is HDLC. To configure PPP encapsulation, use the following command in interface configuration mode:

Command	Purpose
<code>encapsulation ppp</code>	Configures PPP encapsulation.

Configuring Encapsulation for Frame Relay or X.25 Networks

If traffic from this ISDN interface crosses a Frame Relay or X.25 network, the appropriate addressing and encapsulation tasks must be completed as required for Frame Relay or X.25 networks.

See the sections “Sending Traffic over Frame Relay, X.25, or LAPB Networks” in the chapter “Configuring Legacy DDR Spokes” for more information about addressing, encapsulation, and other tasks necessary to configure Frame Relay or X.25 networks.

Configuring Encapsulation for Combinet Compatibility

Historically, Combinet devices supported only the Combinet Proprietary Protocol (CPP) for negotiating connections over ISDN B channels. To enable Cisco routers to communicate with those Combinet bridges, the Cisco IOS software supports a new CPP encapsulation type.

To enable routers to communicate over ISDN interfaces with Combinet bridges that support only CPP, use the following commands in interface configuration mode:

	Command	Purpose
Step 1	<code>encapsulation cpp</code>	Specifies CPP encapsulation.
Step 2	<code>cpp callback accept</code>	Enables CPP callback acceptance.
Step 3	<code>cpp authentication</code>	Enables CPP authentication.

Now most Combinet devices support PPP. Cisco routers can communicate over ISDN with these devices by using PPP encapsulation, which supports both routing and fast switching.

Cisco 700 and 800 series routers and bridges (formerly Combinet devices) support only IP, IPX, and bridging. For AppleTalk, Cisco routers automatically perform half-bridging with Combinet devices. For more information about half-bridging, see the section “Configuring PPP Half-Bridging” in the “Configuring Media-Independent PPP and Multilink PPP” chapter later in this publication.

Cisco routers can also half-bridge IP and IPX with Combinet devices that support only CPP. To configure this feature, you only need to set up the addressing with the ISDN interface as part of the remote subnet; no additional commands are required.

Configuring Automatic Detection of Encapsulation Type of Incoming Calls

You can enable a serial or ISDN interface to accept calls and dynamically change the encapsulation in effect on the interface when the remote device does not signal the call type. For example, if an ISDN call does not identify the call type in the Lower Layer Compatibility fields and is using an encapsulation that is different from the one configured on the interface, the interface can change its encapsulation type at that time.

This feature enables interoperability with ISDN terminal adapters that use V.120 encapsulation but do not signal V.120 in the call setup message. An ISDN interface that by default answers a call as synchronous serial with PPP encapsulation can change its encapsulation and answer such calls.

Automatic detection is attempted for the first 10 seconds after the link is established or the first 5 packets exchanged over the link, whichever is first.

To enable automatic detection of encapsulation type, use the following commands in interface configuration mode:

Command	Purpose
<code>autodetect encapsulation <i>encapsulation-type</i></code>	Enables automatic detection of encapsulation type on the specified interface.

You can specify one or more encapsulations to detect. Cisco IOS software currently supports automatic detection of PPP and V.120 encapsulations.

Configuring Network Addressing

When you configure networking, you specify how to reach the remote recipient. To configure network addressing, use the following commands beginning in interface configuration mode:

	Command	Purpose
Step 1	<pre>dialer map protocol next-hop-address name hostname speed 56 64 dial-string[:isdn-subaddress]</pre> <p>or</p> <pre>dialer map protocol next-hop-address name hostname spc [speed 56 64] [broadcast] dial-string[:isdn-subaddress]</pre>	<p>Defines the protocol address of the remote recipient, host name, and dialing string; optionally, provides the ISDN subaddress; sets the dialer speed to 56 or 64 kbps, as needed.</p> <p>(Australia) Uses the spc keyword that enables ISDN semipermanent connections.</p>
Step 2	<pre>dialer-group group-number</pre>	Assigns the interface to a dialer group to control access to the interface.
Step 3	<pre>dialer-list dialer-group list access-list-number</pre>	Associates the dialer group number with an access list number.
Step 4	<pre>access-list access-list-number {deny permit} protocol source address source-mask destination destination-mask</pre>	Defines an access list permitting or denying access to specified protocols, sources, or destinations.

Australian networks allow semipermanent connections between customer routers with PRIs and the TS-014 ISDN PRI switches in the exchange. Semipermanent connections are offered at better pricing than leased lines.

Packets that are permitted by the access list specified by the **dialer-list** command are considered interesting and cause the router to place a call to the identified destination protocol address.



Note

The access list reference in Step 4 of this task list is an example of the access list commands allowed by different protocols. Some protocols might require a different command form or might require multiple commands. See the relevant chapter in the appropriate network protocol configuration guide (for example, the *Cisco IOS AppleTalk and Novell IPX Configuration Guide*) for more information about setting up access lists for a protocol.

For more information about defining outgoing call numbers, see the sections “Configuring Access Control for Outgoing Calls” in the chapters “Configuring Legacy DDR Spokes” or “Configuring Legacy DDR Hubs” later in this manual.

Overriding the Default TEI Value

You can configure ISDN terminal endpoint identifier (TEI) negotiation on individual ISDN interfaces. TEI negotiation is useful for switches that may deactivate Layers 1 or 2 when there are no active calls. Typically, this setting is used for ISDN service offerings in Europe and connections to DMS 100 switches that are designed to initiate TEI negotiation.

By default, TEI negotiation occurs when the router is powered up. The TEI negotiation value configured on an interface overrides the default or global TEI value. On PRI interfaces connecting to DMS 100 switches, the router will change the default TEI setting to **isdn tei first-call**. To apply TEI negotiation to a specific PRI interface, use the following command in interface configuration mode:

Command	Purpose
<code>isdn tei [first-call powerup]</code>	Determines when ISDN TEI negotiation occurs.

Configuring ISDN Calling Number Identification

A router might need to supply the ISDN network with a billing number for outgoing calls. Some networks offer better pricing on calls in which the number is presented. When configured, the calling number information is included in the outgoing Setup message.

To configure the interface to identify the billing number, use the following command in interface configuration mode:

Command	Purpose
<code>isdn calling-number <i>calling-number</i></code>	Specifies the calling party number.

This command can be used with all ISDN PRI switch types.

Configuring ISDN Voice Calls

All incoming ISDN analog modem calls that come in on an ISDN PRI receive signaling information from the ISDN D channel. The D channel is used for circuit-switched data calls and analog modem calls. To enable all incoming ISDN voice calls to access the Cisco AS5200 and AS5300 call switch module and integrated modems, use the following command beginning in interface configuration mode:

Command	Purpose
<code>isdn incoming-voice modem</code>	Routes incoming ISDN modem calls to the modem module.

Configuring Inclusion of the Sending Complete Information Element

In some geographic locations, such as Hong Kong and Taiwan, ISDN switches require that the Sending Complete information element be included in the outgoing Setup message to indicate that the entire number is included. This information element is generally not required in other locations.

To configure the interface to include the Sending Complete information element in the outgoing call Setup message, use the following command in interface configuration mode:

Command	Purpose
<code>isdn sending-complete</code>	Includes the Sending Complete information element in the outgoing call Setup message.

Configuring NSF Call-by-Call Support

Network-Specific Facilities (NSF) are used to request a particular service from the network or to provide an indication of the service being provided. Call-by-call support means that a B channel can be used for any service; its use is not restricted to a certain preconfigured service, such as incoming 800 calls or an outgoing 800 calls. This specific NSF call-by-call service supports outgoing calls configured as voice calls.

This NSF call-by-call support feature is vendor-specific; only routers connected to AT&T Primary-4ESS switches need to configure this feature. This feature is supported on channelized T1.

To enable the router to for NSF call-by-call support and, optionally, to place outgoing voice calls, complete the following steps:

-
- Step 1** Configure the controller for ISDN PRI.
 - Step 2** Configure the D channel interface to place outgoing calls, using the **dialer map** command with a **dialing-plan** keyword. You can enter a **dialer map** command for each dialing plan to be supported.
 - Step 3** Define the dialer map class for that dialing plan.

To define the dialer map class for the dialing plan, use the following commands beginning in global configuration mode:

	Command	Purpose
Step 1	<code>map-class dialer <i>classname</i></code>	Specifies the dialer map class, using the dialing-plan keyword as the class name.
Step 2	<code>dialer voice-call</code>	(Optional) Enables voice calls.
Step 3	<code>dialer outgoing <i>classname</i></code>	Configures the specific dialer map class to make outgoing calls.



Note

To set the called party type to international, the dialed number must be prefaced by 011.

Table 18 lists the NSF dialing plans and supported services offered on AT&T Primary-4ESS switches.

Table 18 NSF Supported Services on AT&T Primary-4ESS Switches

NSF Dialing Plan	Data	Voice	International
Software Defined Network (SDN) ¹	Yes	Yes	Global SDN
MEGACOMM	No	Yes	Yes
ACCUNET	Yes	Yes	Yes

1. The dialing plan terminology in this table is defined and used by AT&T.

Configuring Multiple ISDN Switch Types

You can apply an ISDN switch type on a per-interface basis, thus extending the existing global **isdn switch-type** command to the interface level. This allows PRI and BRI to run simultaneously on platforms that support both interface types.

A global ISDN switch type is required and must be configured on the router before you can configure a switch type on an interface. To configure multiple ISDN switch types for a PRI interface using a channelized E1 or channelized T1 controller, use the following command in global configuration mode:

Command	Purpose
<code>isdn switch-type switch-type</code>	Applies a global ISDN switch type.

You must ensure the ISDN switch type is valid for the ISDN interfaces on the router. Table 17 lists valid ISDN switch types for BRI and PRI interfaces.



Note

When you configure an ISDN switch type on the channelized E1 or T1 controller, this switch type is applied to all time slots on that controller. For example, if you configure channelized T1 controller 1:23, which corresponds to serial interface 1, with the ISDN switch type keyword **primary-net5**, then all time slots on serial interface 1 (and T1 controller 1) will use the Primary-Net5 switch type.

The following restrictions apply to the Multiple ISDN Switch Types feature:

- You must configure a global ISDN switch type using the existing **isdn switch-type** global configuration command before you can configure the ISDN switch type on an interface. Because global commands are processed before interface level commands, the command parser will not accept the **isdn switch-type** command on an interface unless a switch type is first added globally. Using the **isdn switch-type** global command allows for backward compatibility.
- If an ISDN switch type is configured globally, but not at the interface level, then the global switch type value is applied to all ISDN interfaces.
- If an ISDN switch type is configured globally and on an interface, then the interface level switch type supersedes the global switch type at initial configuration. For example, if the global BRI switch-type keyword **basic-net3** is defined, and the interface-level BRI switch-type keyword is **basic-ni**, then the National ISDN switch type is the value applied to that BRI interface.
- The ISDN global switch type value is only propagated to the interface level on initial configuration or router reload. If you reconfigure the global ISDN switch type, the new value is not applied to subsequent interfaces. Therefore, if you require a new switch type for a specific interface, you must configure that interface with the desired ISDN switch type.
- If an ISDN global switch type is not compatible with the interface type you are using, or you change the global switch type and it is not propagated to the interface level, as a safety mechanism, the router will apply a default value to the interface level, as indicated in Table 19.

Table 19 ISDN PRI and ISDN BRI Global Switch Type Keywords

Global Switch Type	BRI Interface	PRI Interface
basic-net3	basic-net3	primary-net5
primary-ts014	basic-ts013	primary-ts014
primary-ni	basic-ni	primary-ni

If, for example, you reconfigure the router to use global switch type keyword **basic-net3**, the router will apply the Primary-Net5 switch type to PRI interfaces and the NET3 ISDN switch type to any BRI interfaces. You can override the default switch assignment by configuring a different ISDN switch type on the associated interface.

Configuring B Channel Outgoing Call Order

You can configure the router to select the first available B channel in ascending order (channel B1) or descending order (channel B23 for a T1 and channel B30 for an E1). To configure the optional task of selecting B channel order for outgoing calls for PRI interface types, use the following command in interface configuration mode:

Command	Purpose
<code>isdn bchan-number-order {ascending descending}</code>	Enables B channel selection for outgoing calls on a PRI interface (optional).

Before configuring the ISDN PRI on your router, check with your service vendor to determine if the ISDN trunk call selection is configured for ascending or descending order. If there is a mismatch between the router and switch with regard to channel availability, the switch will send back an error message stating the channel is not available. By default, the router will select outgoing calls in descending order.

Performing Configuration Self-Tests

To test the ISDN configuration, use any of the following EXEC commands. See the *Cisco IOS Debug Command Reference* publication for information about the **debug** commands.

Command	Purpose
<code>show controllers t1 slot/port</code>	Checks Layer 1 (physical layer) of the PRI over T1.
<code>show controllers e1 slot/port</code>	Checks Layer 1 (physical layer) of the PRI over E1.
<code>show isdn status</code>	Checks the status of PRI channels.

Command	Purpose
<code>debug q921</code>	Checks Layer 2 (data link layer).
<code>debug isdn events</code> or <code>debug q931</code> or <code>debug dialer</code> or <code>show dialer</code>	Checks Layer 3 (network layer).

Monitoring and Maintaining ISDN PRI Interfaces

To monitor and maintain ISDN interfaces, use any of the following EXEC commands:

Command	Purpose
<code>show interfaces serial slot/port bchannel channel-number</code> (Cisco 7500 series) or <code>show interfaces serial number bchannel channel-number</code> (Cisco 4000 series)	Displays information about the physical attributes of the ISDN PRI over T1 B and D channels.
<code>show interfaces serial slot/port bchannel channel-number</code> (Cisco 7500 series) or <code>show interfaces serial number bchannel channel-number</code> (Cisco 4000 series)	Displays information about the physical attributes of the ISDN PRI over E1 B and D channels.
<code>show controllers t1 [slot/port]</code> (Cisco 7500 series) or <code>show controllers t1 number</code> (Cisco 4000 series)	Displays information about the T1 links supported on the ISDN PRI B and D channels.
<code>show controllers e1 [slot/port]</code> (Cisco 7500 series) or <code>show controllers e1 number</code> (Cisco 4000 series)	Displays information about the E1 links supported on the ISDN PRI B and D channels.
<code>show isdn {active history memory services status [dsl serial number] timers}</code>	Displays information about current calls, history, memory, services, status of PRI channels, or Layer 2 or Layer 3 timers. (The service keyword is available for PRI only.)
<code>show dialer [interface type number]</code>	Obtains general diagnostic information about the specified interface.

Configuring Robbed-Bit Signaling for Analog Calls over T1 Lines

The Cisco AS5200 access server supports robbed-bit signaling for receiving and sending analog calls on T1 lines. Robbed-bit signaling emulates older analog trunk and line in-band signaling methods that are sent in many networks.

In countries that support T1 framing (such as the United States and Canada), many networks send supervisory and signaling information to each other by removing the 8th bit of each time slot of the 6th and 12th frame for superframe (SF) framing. For networks supporting extended superframe (ESF) framing, the 6th, 12th, 18th, and 24th frames are affected. This additional signaling information is added to support channel banks in the network that convert various battery and ground operations on analog lines into signaling bits.

Robbed-bit signaling configured on the Cisco AS5200 access server enables integrated modems in to answer and send analog calls. Robbed bits are forwarded over digital lines. To support analog signaling over T1 lines on the Cisco AS5200 access server, robbed-bit signaling must be enabled.



Note

The signal type configured on the access server must match the signal type offered by your telco provider. Ask your telco provider which signal type to configure on each T1 controller.

The Cisco AS5200 access server has two controllers: controller T1 1 and controller T1 0, which must be configured individually.

To configure robbed-bit signaling support for calls made and received, use the following commands beginning in global configuration mode:

	Command	Purpose
Step 1	<code>controller t1 0</code>	Enables the T1 0 controller, and enter controller configuration mode.
Step 2	<code>cablelength long <i>dbgain-value</i> <i>dbloss-value</i></code>	If the channelized T1 line connects to a smart jack instead of a CSU, sets pulse equalization (use parameter values specified by your telco service provider).
Step 3	<code>framing <i>esf</i></code>	Sets the framing to match that of your telco service provider, which in most cases is <i>esf</i> .
Step 4	<code>linecode <i>b8zs</i></code>	Sets the line-code type to match that of your telco service provider, which in most cases is <i>b8zs</i> .
Step 5	<code>clock source line primary</code>	Configures one T1 line to serve as the primary or most stable clock source line.
Step 6	<code>cas-group <i>channel-number</i> <i>timeslots</i> <i>range</i> type <i>signal</i></code>	Configures channels to accept voice calls. This step creates interfaces that you can configure.
Step 7	<code>fdl {<i>att</i> <i>ansi</i>}</code>	Sets the facilities data-link exchange standard for the CSU, as specified by your telco service provider.

If you want to configure robbed-bit signaling on the other T1 controller, repeat Steps 1 through 7, making sure in Step 5 to select T1 controller line 1 as the secondary clock source.

If you want to configure ISDN on the other controller, see the section “ISDN PRI Configuration Task List” in this chapter. If you want to configure channel groupings on the other controller, see the chapter “Configuring Synchronous Serial Ports” in this publication; specify the channel groupings when you specify the interface.

See the section “Robbed-Bit Signaling Examples” at the end of this chapter for configuration examples.

Configuring CAS for Analog Calls over E1 Lines

The Cisco AS5200 and AS5300 access servers support CAS for channelized E1 lines, which are commonly deployed in networks in Latin America, Asia, and Europe. CAS is configured to support channel banks in the network that convert various battery and ground operations on analog lines into signaling bits, which are forwarded over digital lines.

CAS is call signaling that is configured on an E1 controller and enables the access server to send or receive analog calls. The signaling uses the 16th channel (time slot); thus, CAS fits in the out-of-band signaling category.

Once CAS is configured on a single E1 controller, up to 30 remote users can simultaneously dial in to the Cisco AS5200 and Cisco AS5300 access servers through networks running the R2 protocol. The R2 protocol is an international signaling standard for analog connections. Because R2 signaling is not supported in the Cisco AS5200 and Cisco AS5300 access servers, an E1-to-E1 converter is required. (Refer to Figure 37.)

Because the Cisco AS5200 and Cisco AS5300 access servers have more than one physical E1 port on the dual E1 PRI board, up to 60 simultaneous connections can be made through one dual E1 PRI board.

Figure 37 Remote PC Accessing Network Resources Through the Cisco AS5200 Access Server

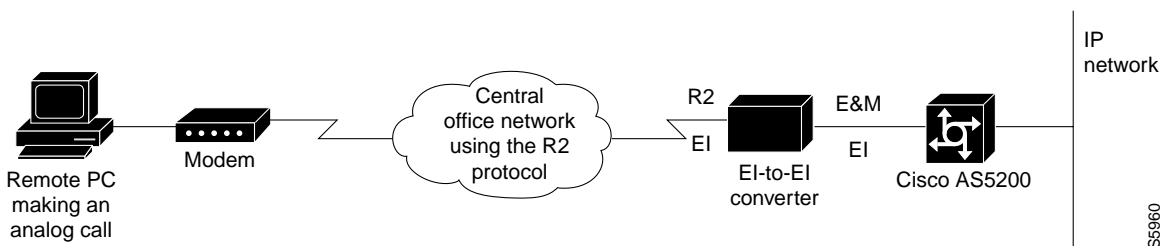

Note

For information on how to configure an Anadigicom E1-to-E1 converter, see to the documentation that came with the converter.



Note

The dual E1 PRI card must be installed in the Cisco AS5200 access server before you can configure CAS.

Configuring CAS

To configure the E1 controllers in the Cisco AS5200 access server, use the following commands beginning in global configuration mode:

	Command	Purpose
Step 1	<code>controller e1 number</code>	Defines the controller location in the Cisco AS5200/AS5300 by unit number, ranging from 1 to 2.
Step 2	<code>cas-group channel-number timeslots range type signal</code>	Configures CAS and the R2 signaling protocol on a specified number of time slots.
Step 3	<code>framing crc4</code>	Defines the framing characteristics as CRC4.
Step 4	<code>linecode hdb3</code>	Defines the line code as HDB3.
Step 5	<code>clock source line primary¹</code>	Specifies one E1 line to serve as the primary or most stable clock source line.

1. Specify the other E1 line as the secondary clock source with the `clock source line secondary` command.

If you do not specify the time slots, CAS is configured on all 30 B channels and one D channel on the specified controller.

See the section “ISDN CAS Examples” for configuration examples.

Configuring Switched 56K Digital Dial-In over Channelized T1 and Robbed-Bit Signaling

Internet service providers (ISPs) can provide switched 56-kbps access to their customers using a Cisco AS5300 or Cisco AS5200 access server. Switched 56K digital dial-in enables many services for ISPs. When using traditional ISDN PRI, the access server uses the bearer capability to determine the type of service. However when providing switched 56K over a CT1 RBS connection, the digital signal level 0 (DS0s) in the access server can be configured to provide either modem or 56-kbps data service. The dial-in user can access a 56-kbps data connection using either an ISDN BRI connection or a 2- or 4-wire switched 56-kbps connection. The telco to which the access server connects must configure its switches to route 56-kbps data calls and voice (modem) calls to the appropriate DS0.

Likewise, an enterprise can provide switched 56-kbps digital dial-in services to its full time telecommuters or small remote offices using ISDN PRI or a CT1 RBS connection.

Switched 56K digital dial-in offers the following benefits:

- Enables ISDN BRI clients to connect to a Cisco AS5300 or Cisco AS5200 access server over switched 56K and T1 CAS.
- Provides switched 56K dial-in services over T1 CAS to remote clients that do not have access to ISDN BRI, for example, a remote PC making digital calls over a 2- or 4-wire switched 56-kbps connection and a CSU.

The following prerequisites apply to the Switched 56K Digital Dial-In feature:

- The remote device could be an ISDN BRI end point such as a terminal adapter or BRI router. In this scenario, the CSU/DSU is irrelevant. For 2- or 4-wire switched 56K remote clients, the remote endpoint must be compatible with the service of the carrier. Different carriers may implement different versions of switched 56K end points.
- A CSU/DSU must be present at the remote client side of the connection. Otherwise, switched 56K connections are not possible. The Cisco AS5300 and Cisco AS5200 access servers have built-in CSU/DSUs.
- The telco must configure its side of the T1 connection to deliver 56-kbps data calls to the correct range of DS0s. If you do not want to dedicate all the DS0s or time slots on a single T1 to switched 56K services, be sure to negotiate with the telco about which DS0s will support switched 56K and which DS0s will not.
- Cisco IOS Release 11.3(2)T or later must be running on the access server.

The following restrictions apply to Switched 56K digital dial-in:

- A Cisco AS5300 or Cisco AS5200 only supports incoming switched 56K calls. Dialing out with switched 56K is not supported at this time.
- Switched 56K over E1 is not supported. Only switched 56K over T1 is supported.
- Analog modem calls are not supported over DS0s that are provisioned for switched 56K. For a configuration example, see the section “Switched 56K and Analog Modem Calls over Separate T1 CAS Lines” later in this chapter.
- Certain types of T1 lines, such as loop start and ground start, might not support this service. Contact your telco vendor to determine if this feature is available.

Switched 56K Scenarios

The following scenarios are provided to show multiple applications for supporting switched 56K over T1 CAS:

- Switched 56K and Analog Modem Calls into T1 CAS
- Basic Call Processing Components
- ISDN BRI Calls into T1 CAS

Switched 56K and Analog Modem Calls into T1 CAS

Figure 38 shows a sample network scenario using switched 56K. Two remote PCs are dialing in to the same Cisco AS5300 access server to get access to the Internet. The desktop PC is making switched 56K digital calls through an external CSU/DSU. The laptop PC is making analog modem calls through a 28.8-kbps modem. The Cisco AS5300 access server dynamically assigns IP addresses to each node and forwards data packets off to the switched 56K channels and onboard modems, respectively.

Figure 38 PCs Making Switched 56K and Analog Modem Calls into a Cisco AS5300 Access Server

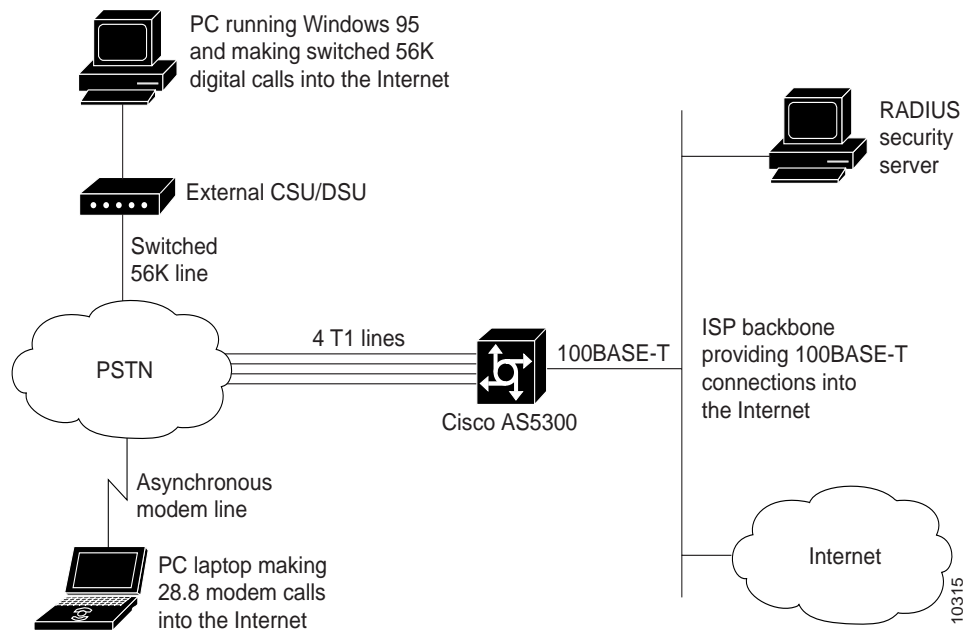

For configuration examples, see the section “Comprehensive Switched 56K Startup Configuration” at the end of this chapter.

Basic Call Processing Components

Figure 39 shows the basic components that process switched 56K calls and analog modem calls on board a Cisco AS5200 and AS5300 access server. Switched 56K and modem calls are signaling using robbed-bit signaling. Digital switched 56K calls utilize logical serial interfaces just like in ISDN PRI. Modem calls utilize asynchronous interfaces, lines, and modems.



Note

The BRI terminal must originate its calls with a bearer capability of 56 kbps.

Figure 39 Processing Components for Switched 56K Calls Versus Analog Modem Calls

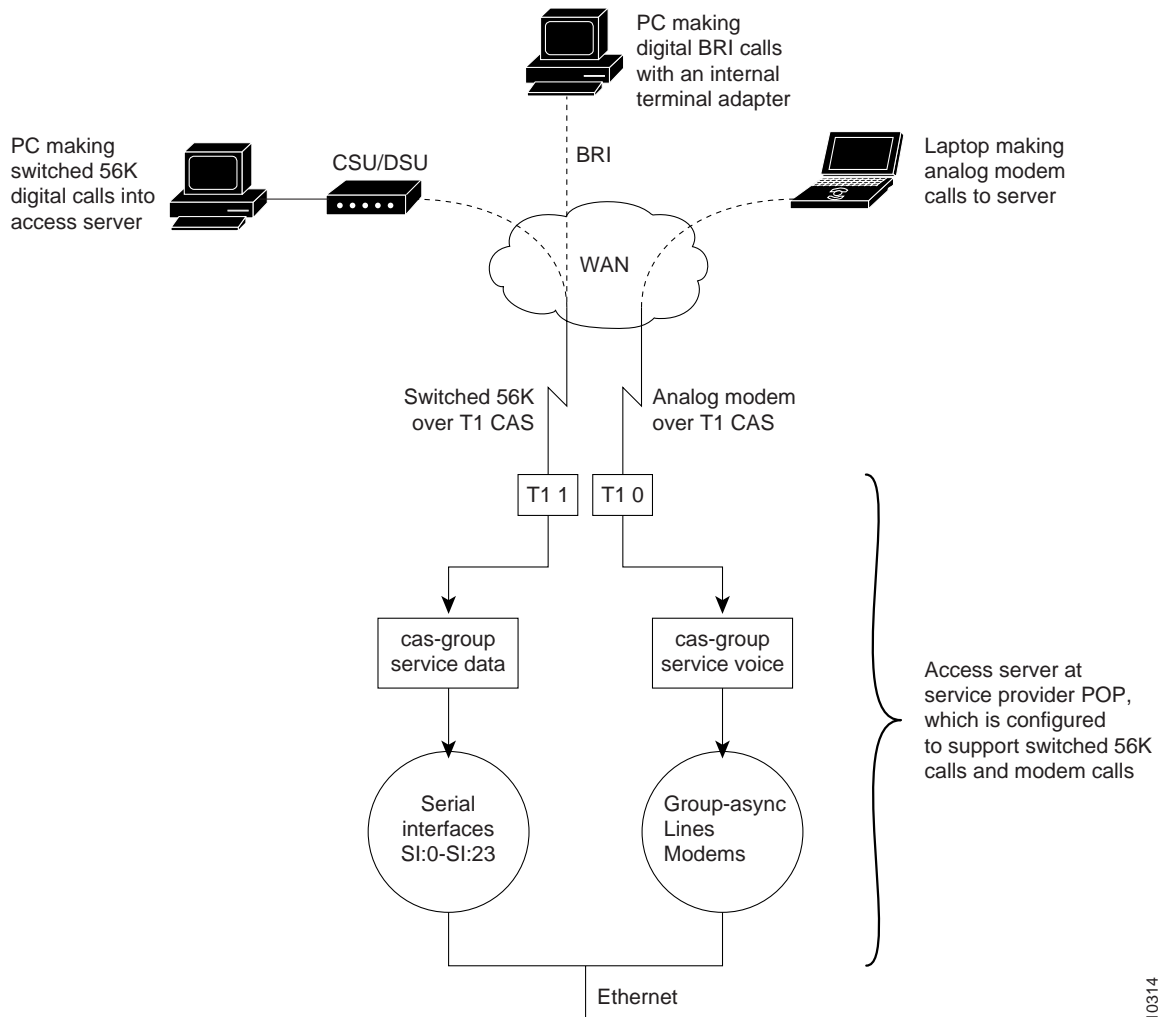
**Note**

The Cisco IOS software does enable you to configure one T1 controller to support both switched 56K digital calls and analog modem calls. In this scenario, Figure 39 would show all calls coming into the access server through one T1 line and controller. However, you must negotiate with the telco which DS0s will support switched 56K services and which DS0s will not. On the access server, analog modem calls are not supported over DS0s that are provisioned for switched 56K. For an example software configuration, see the section “Mixture of Switched 56K and Modem Calls over CT1 CAS” at the end of this chapter.

ISDN BRI Calls into T1 CAS

Figure 40 shows how switched 56K functionality can be used to forward ISDN BRI network traffic to a Cisco AS5300 access server, which is configured for switched 56K robbed-bit signaling over CT1.

**Note**

The BRI terminal must originate its calls with a bearer capability of 56 kbps.

Figure 40 Remote PC Making BRI Digital Calls via Switched 56K to a Cisco AS5300 Access Server

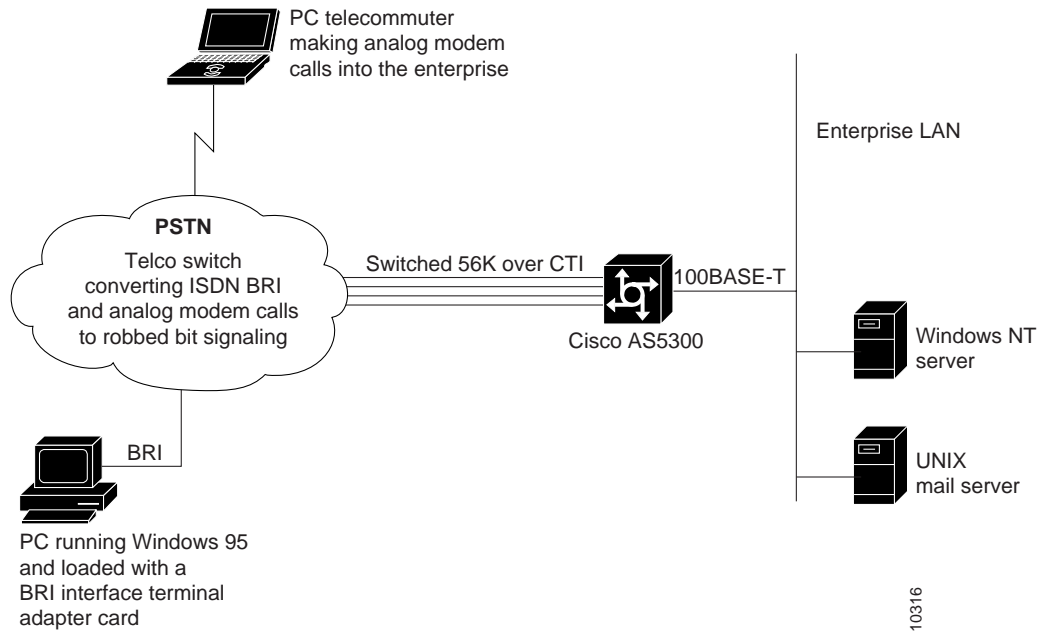

For a configuration example on the Cisco AS5300 access server, see the section “Comprehensive Switched 56K Startup Configuration” at the end of this chapter.

Figure 41 shows a sample network scenario using switched 56K. Two remote PCs are dialing in to the same Cisco AS5300 access server to get access to the Internet. The desktop PC is making switched 56K digital calls through an external CSU/DSU. The laptop PC is making analog modem calls through a 28.8-kbps modem. The Cisco AS5300 access server dynamically assigns IP addresses to each node and forwards data packets off to the switched 56K channels and onboard modems respectively.

Figure 41 PCs Making Switched 56K and Analog Modem Calls into a Cisco AS5300 Access Server

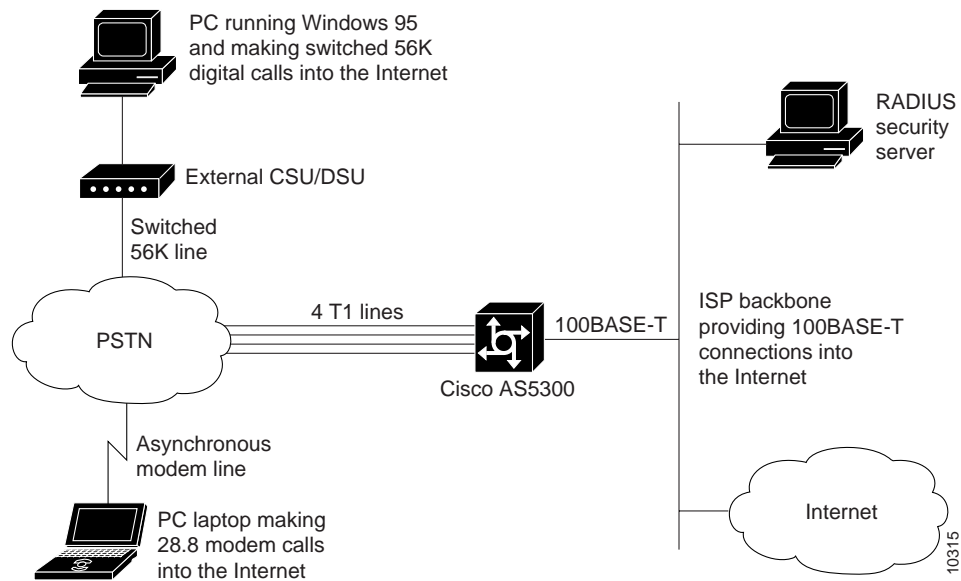

For the startup running configuration on the Cisco AS5300 access server shown in Figure 41, see the section “Comprehensive Switched 56K Startup Configuration” later in this chapter.

Configuring Switched 56K Services

This section describes how to configure switched 56K services on an access server. After the **cas-group** command is enabled for switched 56K services, a logical serial interface is automatically created for each 56K channel, which must also be configured.

To configure an access server to support switched 56K digital calls, use the following commands beginning in privileged EXEC mode:

	Command	Purpose
Step 1	<code>configure terminal</code>	Enters global configuration mode.
Step 2	<code>controllers t1 number</code>	Specifies a T1 controller.
Step 3	<code>framing {sf esf}</code>	Sets the framing.
Step 4	<code>linecode {ami b8zs}</code>	Defines the line code.
Step 5	<code>clock source {line {primary secondary} internal}</code>	Specifies the clocking.
Step 6	<code>cas-group channel timeslots range type signal</code>	Configures robbed-bit signaling for a range of time slots. A logical serial interface is automatically created for each switched 56K channel.
Step 7	<code>exit</code>	Exits controller configuration mode.
Step 8	<code>interface serial number:number</code>	Specifies logical serial interface, which was dynamically created when the cas-group is issued, and configures the core protocol characteristics for the serial interface.

For configuration examples, see the section “Switched 56K Configuration Examples” later in this chapter.

Configuring E1 R2 Signaling

R2 signaling is an international signaling standard that is common to channelized E1 networks. However, there is no single signaling standard for R2. The International Telecommunication Union Telecommunication Standardization Sector (ITU-T) Q.400-Q.490 recommendation defines R2, but a number of countries and geographic regions implement R2 in entirely different ways. Cisco addresses this challenge by supporting many localized implementations of R2 signaling in its Cisco IOS software.

The following sections offer pertinent information about the E1 R2 signaling feature:

- E1 R2 Signaling Overview
- Configuring E1 R2 Signaling
- Monitoring E1 R2 Signaling
- Troubleshooting E1 R2 Signaling

E1 R2 Signaling Overview

The Cisco E1 R2 signaling default is ITU, which supports the following countries: Denmark, Finland, Germany, Russia (ITU variant), Hong Kong (ITU variant), and South Africa (ITU variant). The expression “ITU variant” means there are multiple R2 signaling types in the specified country, but Cisco supports the ITU variant.

Cisco also supports specific local variants of E1 R2 signaling in the following regions, countries, and corporations:

- Argentina
- Australia
- Bolivia¹
- Brazil
- Bulgaria¹
- China
- Colombia
- Costa Rica
- East Europe²
- Ecuador ITU
- Ecuador LME
- Greece
- Guatemala
- Hong Kong (uses the China variant)
- Indonesia
- Israel
- Korea
- Laos¹
- Malaysia
- Malta¹
- New Zealand
- Paraguay
- Peru
- Philippines
- Saudi Arabia
- Singapore
- South Africa (Panaftel variant)
- Telmex corporation (Mexico)
- Telnor corporation (Mexico)
- Thailand
- Uruguay
- Venezuela
- Vietnam

1. Cisco 3620 and 3640 series routers only.

2. Includes Croatia, Russia, and Slovak Republic.



Note

Only MICA technologies modems support R2 functionality. Microcom modems do not support R2.

The following are benefits of E1 R2 signaling:

- R2 custom localization—R2 signaling is supported for a wide range of countries and geographical regions. Cisco is continually supporting new countries.
- Broader deployment of dial access services—The flexibility of a high-density access server can be deployed in E1 networks.

Figure 42 shows a sample network topology for using E1 R2 signaling with a Cisco AS5300 access server (and the same configuration is valid for the Cisco AS5200 and Cisco AS5800 access servers). All four controllers on the access server are configured with R2 digital signaling. Additionally, localized R2 country settings are enabled on the access server.

Configuration examples are supplied in the “Channelized E1 and Channelized T1 Configuration Examples” at the end of this chapter.

Figure 42 Service Provider Using E1 R2 Signaling and a Cisco AS3640 Router

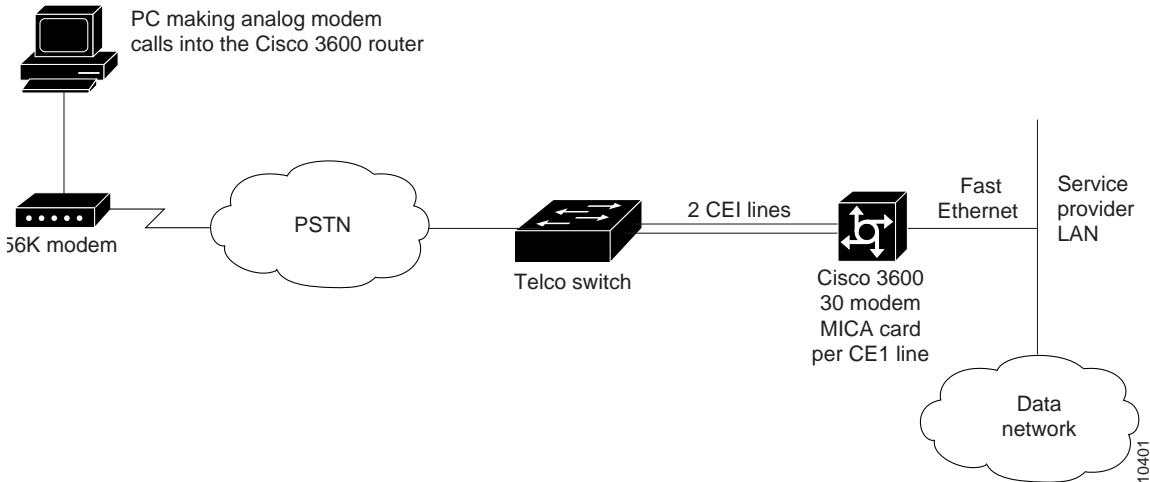

Configuring E1 R2 Signaling

R2 signaling is channelized E1 signaling used in Europe, Asia, and South America. It is equivalent to channelized T1 signaling in North America. There are two types of R2 signaling: line signaling and interregister signaling. R2 line signaling includes R2 digital, R2 analog, and R2 pulse. R2 interregister signaling includes R2 compelled, R2 noncompelled, and R2 semicompelled. These signaling types are configured using the **cas-group** command.

Many countries and regions have their own E1 R2 variant specifications, which supplement the ITU-T Q.400-Q.490 recommendation for R2 signaling. Unique E1 R2 signaling parameters for specific countries and regions are set by entering the **cas-custom channel** command followed by the **country name** command.

Cisco’s implementation of R2 signaling has DNIS support turned on by default. If you enable the **ani** option, the collection of DNIS information is still performed. Specifying the **ani** option does not disable DNIS collection. DNIS is the number being called. ANI is the number of the caller. For example, if you are configuring router A to call router B, then the DNIS number is assigned to router B, the ANI number is assigned to router A. ANI is similar to Caller ID.

To configure support for E1 R2 signaling, use the following commands beginning in global configuration mode:

	Command	Purpose
Step 1	<code>controller e1 slot/port</code>	Specifies the E1 controller that you want to configure with R2 signaling.
Step 2	<p><code>cas-group channel timeslots range type signal</code></p> <p>Replace the <i>signal</i> variable with any of the following choices under R2 analog, R2 digital, or R2 pulse:</p> <pre>r2-analog [dtmf r2-compelled [ani] r2-non-compelled [ani] r2-semi-compelled [ani]] or r2-digital [dtmf r2-compelled [ani] r2-non-compelled [ani] r2-semi-compelled [ani]] or r2-pulse [dtmf r2-compelled [ani] r2-non-compelled [ani] r2-semi-compelled [ani]]</pre>	<p>Configures R2 channel associated signaling on the E1 controller. For a complete description of the available R2 options, see the cas-group command.</p> <p>The R2 part of this command is defined by the <i>signal</i> variable in the cas-group command.</p>
Step 3	<code>cas-custom channel</code>	Enters CAS custom mode, which enables you to localize some of the E1 R2 signaling parameters, such as a specific R2 country settings for Hong Kong. For the customizing to take effect, the <i>channel</i> number used in the cas-custom command must match the <i>channel</i> number specified by the cas-group command.
Step 4	<code>country name use-defaults</code>	<p>Specifies the local country, region, or corporation specification to use with R2 signaling. Replace the <i>name</i> variable with one of the supported country names. We recommend that you include the use-defaults option, which enables the default settings for a specific country. The default country setting is ITU.</p> <p>See the cas-custom command in the <i>Cisco IOS Dial Services Command Reference</i> publication for the list of supported countries, regions, and corporation specifications.</p>
Step 5	<pre>ani-digits answer-signal caller-digits category country default dnis-digits invert-abcd ka kd metering nc-congestion unused-abcd request-category</pre>	<p>(Optional) Further customizes the R2 signaling parameters. Some switch types require you to fine tune your R2 settings. Do not tamper with these commands unless you fully understand the requirements of your switch.</p> <p>In nearly all cases, the country name use-defaults command fully configures the local settings for your country. You should not need to use the commands in Step 5.</p> <p>See the cas-custom command in the <i>Cisco IOS Dial Services Command Reference</i> publication for more information about each signaling command.</p>

Monitoring E1 R2 Signaling

To monitor E1 R2 signaling, use any of the following commands in EXEC mode:

Command	Purpose
<pre>show controllers e1 or show controllers e1 number</pre>	Displays the status for all controllers or a specific controller. Be sure the status indicates the controller is up and there are no alarms or errors (lines 2, 4, 9, and 10, as shown immediately below in the “Monitoring E1 R2 Using the show controllers e1 Command” section).
<pre>show modem csm [slot/port] group number]</pre>	Displays status for a specific modem, as shown below in the “Monitoring E1 R2 Signaling Using the show modem csm Command” section.

Monitoring E1 R2 Using the show controllers e1 Command

```
5300# show controllers e1 0
E1 0 is up.
  Applique type is Channelized E1 - balanced
  No alarms detected.
  Version info of Slot 0: HW: 2, Firmware: 4, PLD Rev: 2

Manufacture Cookie is not programmed.

Framing is CRC4, Line Code is HDB3, Clock Source is Line Primary.
Data in current interval (785 seconds elapsed):
  0 Line Code Violations, 0 Path Code Violations
  0 Slip Secs, 0 Fr Loss Secs, 0 Line Err Secs, 0 Degraded Mins
  0 Errored Secs, 0 Bursty Err Secs, 0 Severely Err Secs, 0 Unavail Secs
Total Data (last 13 15 minute intervals):
  0 Line Code Violations, 0 Path Code Violations,
  0 Slip Secs, 12 Fr Loss Secs, 0 Line Err Secs, 0 Degraded Mins,
  0 Errored Secs, 0 Bursty Err Secs, 0 Severely Err Secs, 12 Unavail Secs
```

Monitoring E1 R2 Signaling Using the show modem csm Command

```
5300# show modem csm 1/0
MODEM_INFO: slot 1, port 0, unit 0, tone r2-compelled, modem_mask=0x0000,
modem_port_offset=0
tty_hwidb=0x60E63E4C, modem_tty=0x60C16F04, oobp_info=0x00000000, modem_pool=0x60BC60CC
modem_status(0x0002): VDEV_STATUS_ACTIVE_CALL.
csm_state(0x0205)=CSM_IC5_CONNECTED, csm_event_proc=0x600CFF70, current call thru CAS line
invalid_event_count=0, wdt_timeout_count=0
wdt_timestamp_started is not activated
wait_for_dialing:False, wait_for_bchan:False
pri_chnl=TDM_PRI_STREAM(s0, u3, c7), modem_chnl=TDM_MODEM_STREAM(s1, c0)
dchan_idb_start_index=0, dchan_idb_index=0, call_id=0x0239, bchan_num=6
csm_event=CSM_EVENT_DSX0_CONNECTED, cause=0x0000
ring_no_answer=0, ic_failure=0, ic_complete=3
dial_failure=0, oc_failure=0, oc_complete=0
oc_busy=0, oc_no_dial_tone=0, oc_dial_timeout=0
remote_link_disc=2, stat_busyout=2, stat_modem_reset=0
oobp_failure=0
call_duration_started=00:04:56, call_duration_ended=00:00:00, total_call_duration=00:01:43
The calling party phone number =
The called party phone number = 9993003
total_free_rbs_timeslot = 0, total_busy_rbs_timeslot = 0, total_dynamic_busy_rbs_timeslot
= 0, total_static_busy_rbs_timeslot = 0, min_free_modem_threshold = 0
```

Troubleshooting E1 R2 Signaling

If a connection does not come up, check the following:

- Loose wires, splices, connectors, shorts, bridge taps, and grounds
- Backward send and receive
- Mismatched framing types (for example, CRC-4 versus no CRC-4)
- Send and receive pair separation (crosstalk)
- Faulty line cards or repeaters
- Noisy lines (for example, power and crosstalk)

If you see errors on the line or the line is going up and down, check the following:

- Mismatched line codes (HDB3 versus AMI)
- Receive level
- Frame slips due to poor clocking plan

If problems persist, enable the modem management Call Switching Module (CSM) debug mode, using the **debug modem csm** command, as shown immediately below in the “Debug E1 R1 Signaling Using the debug modem Command” section.

Debug E1 R1 Signaling Using the debug modem Command

```
5300# debug modem csm 1/0
*May 15 04:05:46.675: VDEV_ALLOCATE: slot 2 and port 39 is allocated.

*May 15 04:05:46.675: CSM_RX_CAS_EVENT_FROM_NEAT:(04BF): EVENT_CALL_DIAL_IN at slot 2 and
port 39

*May 15 04:05:46.675: CSM_PROC_IDLE: CSM_EVENT_DSX0_CALL at slot 2, port 39

*May 15 04:05:46.675: Mica Modem(2/39): Configure(0x0)
*May 15 04:05:46.675: Mica Modem(2/39): Configure(0x3)
*May 15 04:05:46.675: Mica Modem(2/39): Configure(0x6)
*May 15 04:05:46.675: Mica Modem(2/39): Call Setup
*May 15 04:05:46.891: Mica Modem(2/39): State Transition to Call Setup
*May 15 04:05:46.891: Mica Modem(2/39): Went offhook
*May 15 04:05:46.891: CSM_PROC_IC1_RING: CSM_EVENT_MODEM_OFFHOOK at slot 2, port 39
```

When the E1 controller comes up, you will see the following messages:

```
%CONTROLLER-3-UPDOWN: Controller E1 0, changed state to up
It also shows these messages for individual timeslots:
%DSX0-5-RBSLINEUP: RBS of controller 1 timeslot 1 is up
%DSX0-5-RBSLINEUP: RBS of controller 1 timeslot 2 is up
%DSX0-5-RBSLINEUP: RBS of controller 1 timeslot 3 is up
%DSX0-5-RBSLINEUP: RBS of controller 1 timeslot 4 is up
%DSX0-5-RBSLINEUP: RBS of controller 1 timeslot 5 is up
%DSX0-5-RBSLINEUP: RBS of controller 1 timeslot 6 is up
%DSX0-5-RBSLINEUP: RBS of controller 1 timeslot 7 is up
%DSX0-5-RBSLINEUP: RBS of controller 1 timeslot 8 is up
```

Enabling International (Taiwan) R1 Modified Signaling

Enabling R1 modified signaling allows a Cisco universal access server to communicate with central office trunks that also use R1 modified signaling. R1 modified signaling is an international signaling standard that is common to channelized T1/E1 networks. Cisco IOS Release 12.1 supports R1 modified signaling customized for Taiwan only. You can configure a channelized T1/E1 interface to support different types of R1 modified signaling, which is used in older analog telephone networks.

This feature allows enterprises and service providers to fully interoperate with the installed Taiwanese telecommunications standards, providing interoperability in addition to the vast array of Cisco IOS troubleshooting and diagnostic capability. This feature will provide customers with a seamless, single-box solution for their Taiwan signaling requirements.



Note

This type of signaling is not the same as ITU R1 signaling; it is R1 signaling modified for Taiwan specifically. In the future, R1 modified signaling will be supported by the Cisco AS5800 access server, and will also be available in Turkey.

The following restrictions are for the use of R1 modified signaling:

- Because different line signaling uses different A/B/C/D bit definitions to represent the line state, you must understand the configuration of the T1/E1 trunk before configuring the CAS group. If the wrong type of provision is configured, the access server might interpret the wrong A/B/C/D bit definitions and behave erratically.

- Cisco access servers (Cisco AS5200, Cisco AS5300, and Cisco AS5800) with Microcom modems cannot support this feature.
- You must know the configuration of the T1/E1 trunk before configuring the cas-group. If there is a trunk provisioning mismatch, performance problems may occur.

R1 Modified Signaling Topology

Figure 43 illustrates a service provider using R1 signaling with E1 and a Cisco AS5200 access server. The network topology would be the same for T1 or a Cisco AS5300 access server.

Figure 43 Service Provider Using E1 R1 Signaling with a Cisco AS5200 Access Server

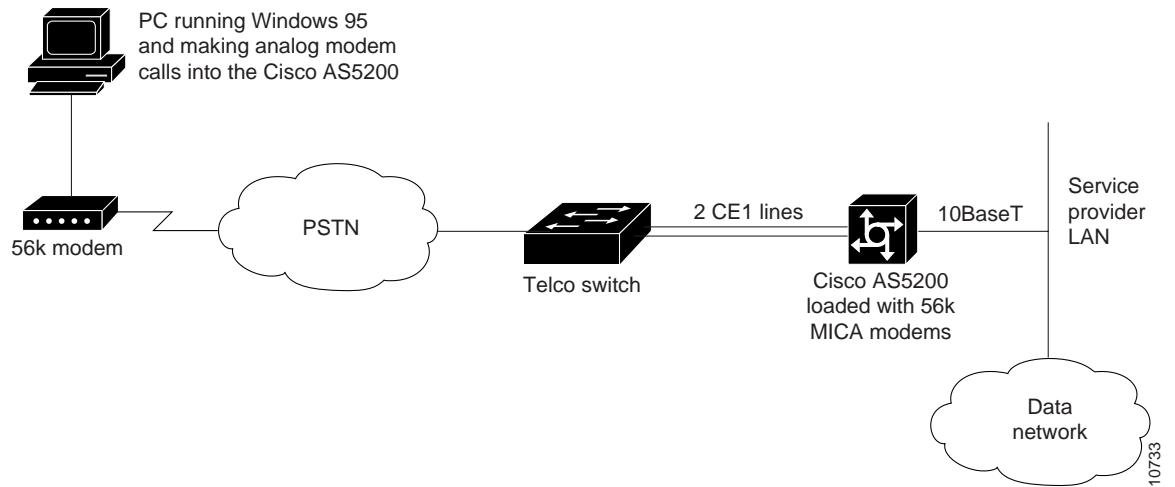
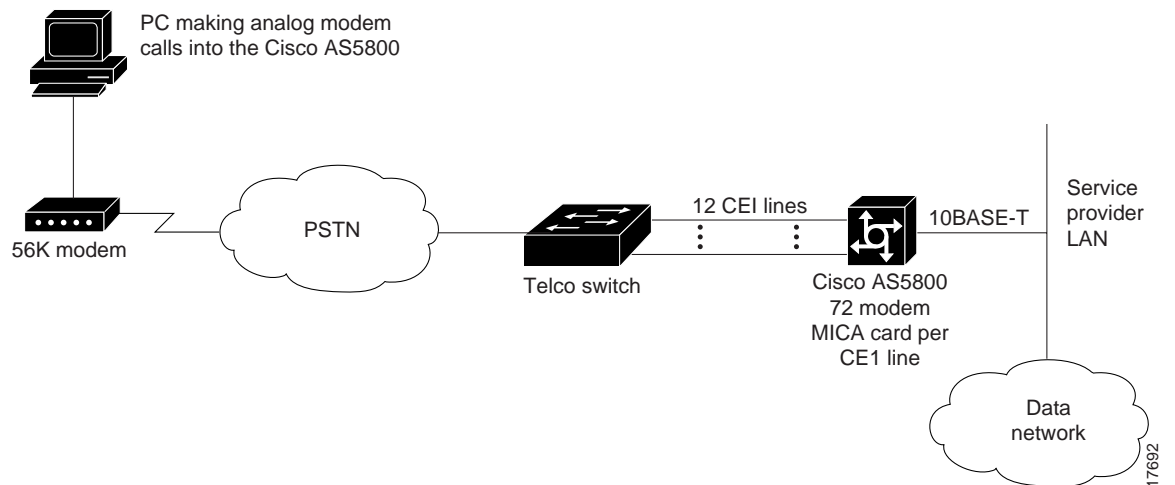

Figure 44 illustrates a service provider using R1 modified signaling with E1 and a Cisco AS5800 access server.

Figure 44 Service Provider Using E1 R1 Modified Signaling with a Cisco AS5800 Access Server



R1 Modified Signaling Configuration Task List

This section describes how to enable R1 modified signaling on your Cisco access server on both a T1 and E1 interface.

Before beginning the tasks in this section, check for the following hardware and software in your system:

- Cisco AS5200, Cisco AS5300, or Cisco AS5800 access server (without a Microcom modem)
- Cisco IOS Release 12.1 software
- MICA feature module
- Portware Version 2.3.1.0 or later

For information on upgrading your Cisco IOS images, modem portware, or modem code, go to the following locations, then select your access server type (AS5200, Cisco AS5300, or Cisco AS5800) and then port information:

- On Cisco Connection Online (CCO):
http://www.cisco.com/univercd/cc/td/doc/product/access/acs_serv/

Or, follow this path:

Cisco Product Documentation/Access Servers and Access Routers/Access Servers

- On the Documentation CD-ROM:
Cisco Product Documentation/Access Servers and Access Routers/Access Servers

To configure R1 modified signaling, perform the tasks in the following sections, as required:

- Configuring R1 Modified Signaling on a T1 Interface
- Configuring R1 Modified Signaling on an E1 Interface



Note

The sample prompts and output are similar for the Cisco AS5200, Cisco AS5300 and Cisco AS5800 access servers.

Configuring R1 Modified Signaling on a T1 Interface

To configure R1 modified signaling on a T1 interface, use the following commands beginning global configuration mode:

	Command	Purpose
Step 1	5800> enable	Enters enable mode.
	Password: <i>password</i>	Enters the password.
	5800#	You have entered enable mode when the prompt changes to 5800#.
Step 2	5800# configure terminal Enter configuration commands, one per line. End with CNTL/Z. 5800(config)#	Enters global configuration mode. You have entered global configuration mode when the prompt changes to 5800(config)#.

	Command	Purpose
Step 3	<pre>5800(config)# controller t1 shelf/slot/port 5800(config-controller)#</pre> <p>or</p> <pre>5200(config)# controller t1 [0 1 2 3] 5200(config-controller)#</pre>	<p>Enters controller configuration mode to configure your T1 controller port. See the <i>Cisco AS5800 Universal Access Server Software Installation and Configuration Guide</i> for port details.</p> <p>The T1 controller ports are labeled 0 to 3 on the quad T1/PRI cards in the Cisco AS5200 and AS5300 access servers.</p>
Step 4	<pre>5800 (config-controller)# framing {sf esf}</pre>	<p>Entering framing sf configures framing to T1 with sf.</p> <p>Entering framing esf configures framing to T1 only.</p>
Step 5	<pre>5800 (config-controller)# linecode {ami b8zs}</pre>	<p>Entering linecode ami configures line code to AMI¹ encoding.</p> <p>Entering linecode b8zs configures line code to b8zs encoding.</p>
Step 6	<pre>5800 (config-controller)# clock source {internal line [primary secondary]}</pre>	<p>Entering clock source internal configures the clock source to the internal clock.</p> <p>Entering clock source line primary configures the clock source to the primary recovered clock.</p> <p>Entering clock source secondary configures the clock source to the secondary recovered clock.</p>
Step 7	<pre>5800(config-controller)# cas-group 1 timeslots 1-24 type {r1-modified {ani-dnis dnis} r1-itu {dnis}}</pre>	<p>Configures the time slots that belong to each E1 circuit for r1-modified or for r1-itu signaling.²</p> <ul style="list-style-type: none"> • The cas-group # ranges from 0 to 23 for CT1. • The timeslot # ranges from 1 to 24 for CT1. • For the type, each CAS group can be configured as one of the Robbed Bit Signaling provisions. • ani-dnis indicates R1 will collect ani and dnis information; dnis indicates R1 will collect only dnis information.
Step 8	<pre>5800(config-if)# ^Z 5800# %SYS-5-CONFIG_I: Configured from console by console</pre>	<p>Returns to enable mode by simultaneously pressing the Ctrl key and the z key. (This message returned is expected and does not indicate an error.)</p>

1. AMI = alternate mark inversion.

2. For a more detailed description of the syntax and variables of this command, see the *Cisco IOS Dial Services Command Reference* publication.

Configuring R1 Modified Signaling on an E1 Interface

To configure R1 modified signaling on an E1 interface, use the following commands beginning in the system enabled mode:

	Command	Purpose
Step 1	5800> enable Password: <i>password</i> 5800#	Enters enable mode. Enters the password. You have entered enable mode when the prompt changes to 5800#.
Step 2	5800# configure terminal Enter configuration commands, one per line. End with CNTL/Z. 5800(config)#	Enters global configuration mode.
Step 3	5800(config)# controller e1 shelf/slot/port 5800(config-controller)# or 5200(config)# controller e1 [0 1 2 3] 5200(config-controller)#	Enters controller configuration mode to configure your T1 controller port. See the <i>Cisco AS5800 Universal Access Server Software Installation and Configuration Guide</i> for port details. The T1 controller ports are labeled 0 to 3 on the quad T1/PRI cards in the Cisco AS5200 and AS5300 access servers.
Step 4	5800 (config-controller)# framing {crc4 no-crc4}	Entering framing crc4 configures framing to E1 with CRC. ¹ Entering framing no-crc4 configures framing to E1 only.
Step 5	5800 (config-controller)# linecode {ami hdb3}	Entering linecode ami configures line code to AMI ² encoding. Entering linecode hdb3 configures line code to HDB ³ encoding.
Step 6	5800 (config-controller)# clock source {internal line [primary secondary]}	Entering clock source internal configures the clock source to the internal clock. Entering clock source line primary configures the clock source to the primary recovered clock. Entering clock source secondary configures the clock source to the secondary recovered clock.
Step 7	5800(config-controller)# cas-group 1 timeslots 1-15, 17-31 type r1-modified {ani-dnis dnis}	Configures the time slots that belong to each E1 circuit for R1 modified signaling. ⁴ <ul style="list-style-type: none"> • The cas-group number ranges from 0 to 30 for CE1. • The timeslot number ranges from 1 to 31 for CE1. • For the type, each CAS group can be configured as one of the robbed bit signaling provisions. • ani-dnis indicates R1 will collect ANI and DNIS information; dnis indicates R1 will collect only DNIS information.

	Command	Purpose
Step 8	<code>5800(config-controller-cas)# cas-custom 1</code>	(Optional.) Enters the channel number to customize.
Step 9	<code>5800(config-controller-cas)# ^z</code> <code>5800#</code> <code>%SYS-5-CONFIG_I: Configured from console by console</code>	Returns to enable mode by simultaneously pressing the Ctrl key and the Z key. This message is normal and does not indicate an error.

1. CRC = cyclic redundancy check.
2. AMI = alternate mark inversion.
3. HDB = high-density bipolar 3.
4. For a more detailed description of the syntax and variables of this command, see the *Cisco IOS Dial Services Command Reference* publication.

Troubleshooting Channelized E1 and Channelized T1

When troubleshooting channelized T1 or E1, you must first determine if the problem is with a particular channel group or with the T1 or E1 line.

If the problem is with a single channel group, you have a potential interface problem.

If the problem is with the T1 or E1 line, or with all channel groups, you have a potential controller problem.

The following sections describe how to determine whether the problem affects an interface or a controller:

- Running Controller Loopback Diagnostic Tests
- Channelized E1 Controller Loopback
- Troubleshooting Channelized E1 and T1 Channel Groups

When you troubleshoot E1 or T1 controllers, first check that the configuration is correct. The framing type and line code should match what the service provider has specified. Then check channel group and PRI-group configurations, especially to verify that the time slots and speeds are what the service provider has specified.

At this point, the **show controllers t1** or **show controllers e1** commands should be used to check for T1 or E1 errors. Use the command several times to determine if error counters are increasing, or if the line status is continually changing. If these errors are occurring, you need to work with the service provider.



Note

Cisco routers do not have CSU capability and do not react to any remote loopback codes at the T1 or E1 level.

Running Controller Loopback Diagnostic Tests

Controller loopback tests are a means to isolate problems and are available for both channelized T1 controllers and channelized E1 controllers. The following loopback tests are documented for isolating T1 and E1 controller issues:

- Local Loopback
- Remote Loopback
- Channelized E1 Controller Loopback

Local Loopback

The local loopback loops the controller both toward the router and toward the line. Because the loopback is done internally to the router, the controller should make the transition to the UP state within approximately 10 seconds, and no further T1 errors should be detected.

All channel groups will be looped back; if the encapsulation on that channel group supports loopbacks (for example, HDLC and PPP), you can test that channel group by pinging the interface address. For example, if you have assigned an IP address to the serial interface defined for a channel group, you can ping that IP address.

To place the controller into local loopback, use the following command in controller configuration mode:

Command	Purpose
<code>loopback local controller</code>	Loops the T1 controller toward the router and toward the line.

To test a channel group, use the following command in EXEC mode:

Command	Purpose
<code>ping protocol protocol-address</code>	Pings the interface address.

Check errors by using the following command in EXEC mode:

Command	Purpose
<code>show controllers t1</code>	Checks errors.

If any errors occur, or the controller fails to change to the up state, please contact the Cisco Technical Assistance Center (TAC).

Because the controller local loopback is bidirectional, the service provider can test the line integrity using a T1 bit error rate tester (BERT) test set.

Remote Loopback

The second T1 controller loopback is a remote loopback. This loopback can be used only if the *entire* T1 goes to a remote CSU. This is not the case with 99.9 percent of channelized T1. When the **loopback remote controller** command is executed, an in-band CSU loop-up code will be sent over the entire T1, which will attempt to loop up the remote CSU. To place the controller in remote loopback, use the following command in controller configuration mode:

Command	Purpose
<code>loopback remote controller</code>	Places the T1 controller in remote loopback.



Note If controller loopbacks are used, they will disrupt service for all channel groups on that interface.

Channelized E1 Controller Loopback

For the E1 controller, only the local loopback is available. Local loopback operates the same as the local loopback on the T1 controller, forming a bidirectional loopback, both toward the router and toward the line. To place the E1 controller in local loopback, use the following command in controller configuration mode:

Command	Purpose
<code>loopback controller</code>	Places the E1 controller in local loopback toward the router and toward the line.

All channel groups will be looped back; if the encapsulation on that channel group supports loopbacks (for example, HDLC and PPP), you can test that channel group by pinging the interface address. For example, if you have assigned an IP address to the serial interface defined for a channel group, you can ping that IP address.

To place the controller into local loopback, use the following command in controller configuration mode:

Command	Purpose
<code>loopback local controller</code>	Loops the T1 controller toward the router and toward the line.

To test a channel group, use the following command in EXEC mode:

Command	Purpose
<code>ping protocol protocol-address</code>	Pings the interface address.

To check errors, if any, use the following command in EXEC mode:

Command	Purpose
<code>show controllers t1</code>	Checks errors.

If any errors occur, they are most likely a hardware problem; please contact the Cisco TAC. In addition, you can ask the service provider to test the line by using a T1 BERT test set.

Troubleshooting Channelized E1 and T1 Channel Groups

Each channelized T1 or channelized E1 channel group is treated as a separate serial interface. To troubleshoot channel groups, first verify configurations and check everything that is normally checked for serial interfaces. You can verify that the time slots and speed are correct for the channel group by checking for CRC errors and aborts on the incoming line.



Note

None of the Cisco channelized interfaces will react to any loop codes. To loop a channelized interface requires that the configuration command be entered manually.

Two loopbacks are available for channel groups and are described in the following sections:

- Interface Local Loopback
- Interface Remote Loopback

Interface Local Loopback

Interface local loopback is a bidirectional loopback, which will loopback toward the router and toward the line. The entire set of time slots for the channel group is looped back. The service provider can use a BERT test set to test the link from the central office to your local router, or the remote router can test using pings to its local interface (which will go from the remote site, looped back at your local site, and return to the interface on the remote site).

To place the serial interface (channel group) into local loopback, use the following command in interface configuration mode:

Command	Purpose
<code>loopback local</code>	Places the serial interface (channel group) in local loopback.

Interface Remote Loopback

Remote loopback is the ability to put the remote DDS CSU/DSU in loopback. It will work only with channel groups that have a single DS0 (1 time slot), and with equipment that works with a latched CSU loopback as specified in AT&T specification TR-TSY-000476, "OTGR Network Maintenance Access and Testing." To place the serial interface (channel group) in remote loopback, use the following command in interface configuration mode:

Command	Purpose
<code>loopback remote interface</code>	Places the serial interface (channel group) in remote loopback.

Using the **loopback remote** interface command sends a latched CSU loopback command to the remote CSU/DSU. The router must detect the response code, at which time the remote loopback is verified.

Channelized E1 and Channelized T1 Configuration Examples

- Channelized E1 Controller
- Channelized T1 Controller
- ISDN PRI Examples
- PRI Groups and Channel Groups on the Same Channelized T1 Controller
- Robbed-Bit Signaling Examples
- Switched 56K Configuration Examples
- ISDN CAS Examples
- E1 R2 Signaling Procedure
- R1 Modified Signaling Configuration—Cisco AS5200
- R1 Modified Signaling Configuration—Cisco AS5800

Channelized E1 Controller

The following example configures a Cisco 7500 series router to acknowledge an E1 line:

```
controller e1 3/0
channel-group 0 timeslots 1
channel-group 8 timeslots 5-15, 20-30
channel-group 12 timeslots 2
channel-group 29 timeslots 31
```

Channelized T1 Controller

The following example applies only to a Cisco 7500 series router. It configures the router to acknowledge a T1 line and its circuits. Four different circuits (and their corresponding serial interfaces) are defined for the second CxCT1 attached to the MIP in slot 4.

```
controller t1 4/1
  framing esf
  linecode b8zs
  channel-group 0 timeslots 1
  channel-group 8 timeslots 5,7,12-15, 20 speed 64
  channel-group 12 timeslots 2
  channel-group 23 timeslots 24
```

The following example configures circuit 0 for PPP encapsulation:

```
interface serial 4/1:0
  ip address 131.108.13.1 255.255.255.0
  encapsulation ppp
```

The following example configures circuit 8 for IP routing and disables IP route cache:

```
interface serial 4/1:8
  ip address 131.108.1.1 255.255.255.0
  no ip route-cache
```

The following example configures circuit 12 for Frame Relay encapsulation and subinterface support:

```
interface serial 4/1:12
  encapsulation frame-relay
  !
  interface serial 4/1:12.1
    ip address 1.1.1.1 255.0.0.0
  !
  interface serial 4/1:12.2
    ip address 2.2.2.2 255.0.0.0
```

The following example configures circuit 23 for IP routing and enables autonomous switching:

```
interface serial 4/1:23
  ip address 3.3.3.3 255.0.0.0
  ip route-cache cbus
```

ISDN PRI Examples

This section contains the following ISDN PRI examples:

- Global ISDN, BRI, and PRI Switch
- Global ISDN and Multiple BRI and PRI Switch Using TEI Negotiation
- NSF Call-by-Call Support
- PRI on a Cisco AS5200 Access Server
- Multiple ISDN Switch Types
- Outgoing B-Channel Ascending Call Order

Global ISDN, BRI, and PRI Switch

The following example shows BRI interface 0 configured for a NET3 ISDN switch type (**basic-net3** keyword) that will override the National ISDN switch type configured globally. The PRI interface (channelized T1 controller) is configured for ISDN switch type Primary-Net5 and is applied only to the PRI.

```
isdn switch-type basic-ni
!
interface BRI0
 isdn switch-type basic-net3
interface serial0:23
! Apply the primary-net5 switch to this interface only.
 isdn switch-type primary-net5
```

Global ISDN and Multiple BRI and PRI Switch Using TEI Negotiation

In the following example, the global ISDN switch type setting is NET3 ISDN (**basic-net3** keyword) and the PRI interface (channelized T1 controller) is configured to use **isdn switch-type primary-net5**. BRI interface 0 is configured for **isdn switch-type basic-ni** and **isdn tei first-call**. TEI first-call negotiation configured on BRI interface 0 overrides the default value (**isdn tei powerup**).

```
isdn switch-type basic-net
!
interface serial0:23
 isdn switch-type primary-net5
 ip address 172.21.24.85 255.255.255.0
!
interface BRI0
 isdn switch-type basic-ni
 isdn tei first-call
```

NSF Call-by-Call Support

The following example configures NSF, which is needed for an AT&T 4ESS switch when it is configured for call-by-call support. In call-by-call support, the PRI 4ESS switch expects some AT&T-specific information when placing outgoing ISDN PRI voice calls. The options are **accunet**, **sdn**, and **megacom**.

This example shows both the controller and interface commands required to make the ISDN interface operational and the DDR commands, such as the **dialer map**, **dialer-group**, and **map-class dialer** commands, that are needed to configure the ISDN interface to make outgoing calls.

```
! The following lines configure the channelized T1 controller; all timeslots are
! configured for ISDN PRI.
!
controller t1 1/1
 framing esf
 linecode b8zs
 pri-group timeslots 1-23
 isdn switchtype primary-4ess
!
! The following lines configure the D channel for DDR. This configuration applies
! to all B channels on the ISDN PRI interface.
!
```

```

interface serial 1/1:23
  description Will mark outgoing calls from AT&T type calls.
  ip address 7.1.1.1 255.255.255.0
  encapsulation ppp
  dialer map ip 7.1.1.2 name tommyjohn class sdnplan 14193460913
  dialer map ip 7.1.1.3 name angus class megaplan 14182616900
  dialer map ip 7.1.1.4 name angus class accuplan 14193453730

dialer-group 1
  ppp authentication chap

map-class dialer sdnplan
  dialer outgoing sdn

map-class dialer megaplan
  dialer voice-call
  dialer outgoing mega

map-class dialer accuplan
  dialer outgoing accu

```

PRI on a Cisco AS5200 Access Server

The following example configures ISDN PRI on the appropriate interfaces for IP dial-in on channelized T1:

```

! T1 PRI controller configuration

controller T1 0
  framing esf
  linecode b8zs
  clock source line primary
  pri-group timeslots 1-24
!
controller T1 1
  framing esf
  linecode b8zs
  clock source line secondary
  pri-group timeslots 1-24
!
interface Serial0:23
  isdn incoming-voice modem
  dialer rotary-group 1
!
interface Serial1:23
  isdn incoming-voice modem
  dialer rotary-group 1
!
interface Loopback0
  ip address 172.16.254.254 255.255.255.0
!
interface Ethernet0
  ip address 172.16.1.1 255.255.255.0
!
interface Group-Async1
  ip unnumbered Loopback0
  ip tcp header-compression passive
  encapsulation ppp
  async mode interactive

```

```

peer default ip address pool default
dialer-group 1
ppp authentication chap pap default
group-range 1 48
!
interface Dialer1
ip unnumbered Loopback0
encapsulation ppp
peer default ip address pool default
ip local pool default 172.16.254.1 172.16.254.48
dialer in-band
dialer-group 1
dialer idle-timeout 3600
ppp multilink
ppp authentication chap pap default

```

The following example configures ISDN PRI on the appropriate interfaces for IP dial-in on channelized E1:

```

! E1 PRI controller configuration

controller E1 0
framing crc4
linecode hdb3
clock source line primary
pri-group timeslots 1-31
!
controller E1 1
framing crc4
linecode hdb3
clock source line secondary
pri-group timeslots 1-31

interface serial0:15
isdn incoming-voice modem
dialer rotary-group 1
!
interface serial1:15
isdn incoming-voice modem
dialer rotary-group 1
!
interface loopback0
ip address 172.16.254.254 255.255.255.0
!
interface ethernet0
ip address 172.16.1.1 255.255.255.0
!
! The following block of commands configures DDR for all the ISDN PRI interfaces
! configured above. The dialer-group and dialer rotary-group commands tie the
! interface configuration blocks to the DDR configuration.
!
interface dialer1
ip unnumbered loopback0
encapsulation ppp
peer default ip address pool default
ip local pool default 172.16.254.1 172.16.254.60
dialer in-band
dialer-group 1
dialer idle-timeout 3600
ppp multilink
ppp authentication chap pap default

```

Multiple ISDN Switch Types

The following example configures ISDN switch type keyword **primary-4ess** on channelized T1 controller 0 and a switch type keyword **primary-net5** for channelized T1 controller 1.

```
controller t1 0
  framing esf
  linecode b8zs
  isdn switchtype primary-4ess
!
controller t1 1
  framing esf
  linecode b8zs
  isdn switchtype primary-net5
```

The following example shows BRI interface 0 configured for switch type keyword **basic-net3** (NET3 ISDN) that will override the global switch type keyword **basic-ni** (National ISDN). The PRI interface (channelized T1 controller), is configured for ISDN switch type keyword **primary-net5** and is applied only to the PRI interface.

```
isdn switch-type basic-ni
!
interface BRI0
  isdn switch-type basic-net3
interface serial0:23
! Apply the primary-net5 switch to this interface only.
  isdn switch-type primary-net5
```

Outgoing B-Channel Ascending Call Order

The following example configures the router to use global ISDN switch-type keyword **primary-ni** and configures the ISDN outgoing call channel selection to be made in ascending order:

```
isdn switch-type primary-ni
!
interface serial0:23
  isdn bchan-number-order ascending
```

PRI Groups and Channel Groups on the Same Channelized T1 Controller

The following example shows a channelized T1 controller configured for PRI groups and for channel groups. The **pri-group** command and the **channel-group** command cannot have overlapping time slots; note the correct time slot configuration in this example.

```
controller t1 0
  channel-group 0 timeslot 1-6
  channel-group 1 timeslot 7
  channel-group 2 timeslot 8
  channel-group 3 timeslot 9-11
  pri-group timeslot 12-24
```

The same type of configuration also applies to channelized E1.

Robbed-Bit Signaling Examples

This section provides example configurations for the T1 controllers on the Cisco AS5200 access server. You can configure the 24 channels of a channelized T1 to support ISDN PRI, robbed-bit signaling, channel grouping, or a combination of all three. It provides the following sections:

- Allocating All Channels for Robbed-Bit Signaling
- Mixing and Matching Channels—Robbed-Bit Signaling and Channel Grouping

Allocating All Channels for Robbed-Bit Signaling

The following example configures all 24 channels to support robbed-bit signaling feature group B on a Cisco AS5200 access server:

```
controller T1 0
cas-group 1 timeslots 1-24 type e&m-fgb
```

Mixing and Matching Channels—Robbed-Bit Signaling and Channel Grouping

The following example shows you how to configure all 24 channels to support a combination of ISDN PRI, robbed-bit signaling, and channel grouping. The range of time slots that you allocate must match the time slot allocations that your central office chooses to use. This is a rare configuration due to the complexity of aligning the correct range of time slots on both ends of the connection.

The following configuration creates serial interfaces 0 to 9, which correspond to ISDN PRI time slots 1 to 10 (shown as serial 1:0 through serial 1:9). The serial line 1:23 is the D channel, which carries the analog signal bits that dial the phone number of the modem and determine if a modem is busy or available. The D channel is automatically created and assigned to time slot 24.

```
controller T1 0
! ISDN PRI is configured on time slots 1 through 10.
pri-group timeslots 1-10
! Channelized T1 data is transmitted over time slots 11 through 16.
channel-group 11 timeslots 11-16
! The channel-associated signal ear and mouth feature group B is configured on
! virtual signal group 17 for time slots 17 to 23, which are used for incoming
! and outgoing analog calls.
cas-group 17 timeslots 17-23 type e&m-fgb
```

There is no specific interface, such as the serial interface shown in the earlier examples, that corresponds to the time slot range.

Switched 56K Configuration Examples

The following switched 56K configuration examples are provided:

- Switched 56K T1 Controller Procedure
- Mixture of Switched 56K and Modem Calls over CT1 CAS
- Switched 56K and Analog Modem Calls over Separate T1 CAS Lines
- Comprehensive Switched 56K Startup Configuration

Switched 56K T1 Controller Procedure

The following procedure shows how to configure one T1 controller on a Cisco AS5300 to support switched 56K digital calls. The Cisco AS5300 has four controllers, which are numbered 0 to 3. If you want all four T1 controllers to support switched 56K calls, then repeat this procedure on each controller.



Note Use this same procedure for configuring a Cisco AS5200 access server.

Step 1 Enter global configuration mode using the **configure terminal** command:

```
router# configure terminal
Enter configuration commands, one per line. End with CNTL/Z.
```

Step 2 Specify a T1 controller with the **controller t1 number** command. Replace the *number* variable with a controller number from 0 to 3.

```
router(config)# controller t1 1
```

Step 3 Configure robbed-bit signaling on a range of time slots, then specify switched 56K digital services using the **cas-group** command. In this example, all calls coming into controller T1 1 are expected to be switched 56K data calls, not analog modem calls.

```
router(config-controller)# cas-group 1 timeslots 1-24 type e&m-fgb service data
```



Note Be sure your signaling type matches the signaling type specified by the central office or telco on the other end. For a list of supported signaling types and how to collect DNIS, see the **cas-group** command reference page for the E1 controller card in the *Cisco IOS Dial Services Command Reference* publication.

Step 4 Set the framing for your network environment. You can choose ESF (enter **framing esf**) or SF (enter **framing sf**).

```
router(config-controller)# framing esf
```

Step 5 Set the line-code type for your network environment. You can choose AMI encoding (enter **linecode ami**) or B8ZS encoding (enter **linecode b8zs**).

```
router(config-controller)# linecode b8zs
```

Mixture of Switched 56K and Modem Calls over CT1 CAS

The following example configures one T1 controller to accept incoming switched 56K digital calls and analog modem calls over the same T1 CAS line. Time slots 1 through 10 are provisioned by the telco to support switched 56K digital calls. Time slots 11 through 24 are provisioned to support analog modem calls. Due to the DS0s provisioning, it is impossible for analog modems calls to be sent over the DS0s that map to time slots 1 through 10.

```
controller T1 0
cas-group 1 timeslots 1-10 type e&m-fgb service data
cas-group 1 timeslots 11-24 type e&m-fgb service voice
framing esf
clock source line primary
linecode b8zs
exit
```

Switched 56K and Analog Modem Calls over Separate T1 CAS Lines

The following example configures one Cisco AS5300 access server to accept 50 percent switched 56K digital calls and 50 percent analog modem calls. The controllers T1 0 and T1 1 are configured to support the switched 56K digital calls using the **cas-group 1 timeslots 1-24 type e&m-fgb service digital** command. The controllers T1 2 and T1 3 are configured to support analog modem calls.

```
controller T1 0
  cas-group 1 timeslots 1-24 type e&m-fgb service data
  framing esf
  clock source line primary
  linecode b8zs
  exit
controller T1 1
  cas-group 1 timeslots 1-24 type e&m-fgb service data
  framing esf
  clock source line secondary
  linecode b8zs
  exit
controller T1 2
  cas-group 1 timeslots 1-24 type e&m-fgb service voice
  framing esf
  clock source internal
  linecode b8zs
  exit
controller T1 3
  cas-group 1 timeslots 1-24 type e&m-fgb service voice
  framing esf
  clock source internal
  linecode b8zs
  exit
copy running-config startup-config
```

Comprehensive Switched 56K Startup Configuration

The startup configuration in this section runs on the Cisco AS5300 access server, as shown in Figure 41. This configuration is for an IP dial-in scenario with a mix of switched 56K calls and modem calls. Switched 56K digital calls come into controllers T1 0 and T1 1. Analog modem calls come into controllers T1 2 and T1 3.

In this example, the switched 56K clients are single endpoints in a remote node configuration. If each switched 56K client were instead a router with a LAN behind it without port address translation (PAT) turned on, then a static address, subnet mask, and route must be configured for each remote endpoint. This configuration would best be done through RADIUS.

After a T1 time slot is configured with robbed-bit signaling using the **cas-group** command with the **service data** option, a logical serial interface is instantly created for each switched 56K channel. For example, signaling configured on all 24 time slots of controller T1 1 dynamically creates serial interfaces S0:0 through S0:23. You must then configure protocol support on each serial interface. No **interface group** command exists for serial interfaces, unlike asynchronous interfaces via the **interface group-async** command. Each serial interface must be individually configured. In most cases, the serial configurations will be identical. To streamline or shorten this configuration task, you might consider using a dialer interface, as shown in the following example.

**Note**

In this example, only analog modem calls encounter the group asynchronous and line interfaces. Switched 56K calls encounter the logical serial interfaces and dialer interface.

```

!
version 11.3
service timestamps debug datetime msec
service timestamps log datetime msec
service password-encryption
no service udp-small-servers
no service tcp-small-servers
!
hostname 5300
!
aaa new-model
aaa authentication login default local
aaa authentication login console enable
aaa authentication login vty local
aaa authentication login dialin radius
aaa authentication ppp default local
aaa authentication ppp dialin if-needed radius
aaa authorization exec local radius
aaa authorization network radius
aaa accounting network start-stop radius
aaa accounting exec start-stop radius
!
enable secret cisco
!
username admin password cisco
async-bootp dns-server 10.1.3.1 10.1.3.2
!
!
! Switched 56K calls come into controllers T1 0 and T1 1. Take note of the keywords !
"service data" in the cas-group command.
!
controller T1 0
 framing esf
 clock source line primary
 linecode b8zs
 cas-group 0 timeslots 1-24 type e&m-fgb service data
!
controller T1 1
 framing esf
 clock source line secondary
 linecode b8zs
 cas-group 1 timeslots 1-24 type e&m-fgb service data
!
! Analog modem calls come into controllers T1 2 and T1 3.
!
controller T1 2
 framing esf
 clock source line internal
 linecode b8zs
 cas-group 2 timeslots 1-24 type e&m-fgb
!
controller T1 3
 framing esf
 clock source line internal
 linecode b8zs
 cas-group 3 timeslots 1-24 type e&m-fgb
!

```

```
interface loopback0
 ip address 10.1.2.62 255.255.255.192
!
interface Ethernet0
 no ip address
 shutdown
!
interface FastEthernet0
 ip address 10.1.1.11 255.255.255.0
 ip summary address eigrp 10.10.1.2.0 255.255.255.192
!
! Interface serial0:0 maps to the first switched 56K channel. The dialer pool-member
! command connects this channel to dialer interface 1.
!
interface Serial0:0
 dialer rotary-group 1
!
interface Serial0:1
 dialer rotary-group 1
!
interface Serial0:2
 dialer rotary-group 1
!
interface Serial0:3
 dialer rotary-group 1
!
interface Serial0:4
 dialer rotary-group 1
!
interface Serial0:5
 dialer rotary-group 1
!
interface Serial0:6
 dialer rotary-group 1
!
interface Serial0:7
 dialer rotary-group 1
!
interface Serial0:8
 dialer rotary-group 1
!
interface Serial0:9
 dialer rotary-group 1
!
interface Serial0:10
 dialer rotary-group 1
!
interface Serial0:11
 dialer rotary-group 1
!
interface Serial0:12
 dialer rotary-group 1
!
interface Serial0:13
 dialer rotary-group 1
!
interface Serial0:14
 dialer rotary-group 1
!
interface Serial0:15
 dialer rotary-group 1
!
interface Serial0:16
 dialer rotary-group 1
```

```
!
interface Serial0:17
  dialer rotary-group 1
!
interface Serial0:18
  dialer rotary-group 1
!
interface Serial0:19
  dialer rotary-group 1
!
interface Serial0:20
  dialer rotary-group 1
!
interface Serial0:21
  dialer rotary-group 1
!
interface Serial0:22
  dialer rotary-group 1
!
! Interface serial 0:23 is the last switched 56K channel for controller T1 0.
!
interface Serial0:23
  dialer rotary-group 1
!
! The switched 56K channels for controller T1 1 begin with interface serial 1:0 and end !
with interface serial 1:23.
!
interface Serial1:0
  dialer rotary-group 1
!
interface Serial1:1
  dialer rotary-group 1
!
interface Serial1:2
  dialer rotary-group 1
!
interface Serial1:3
  dialer rotary-group 1
!
interface Serial1:4
  dialer rotary-group 1
!
interface Serial1:5
  dialer rotary-group 1
!
interface Serial1:6
  dialer rotary-group 1
!
interface Serial1:7
  dialer rotary-group 1
!
interface Serial1:8
  dialer rotary-group 1
!
interface Serial1:9
  dialer rotary-group 1
!
interface Serial1:10
  dialer rotary-group 1
!
interface Serial1:11
  dialer rotary-group 1
!
interface Serial1:12
```

```
dialer rotary-group 1
!
interface Serial1:13
  dialer rotary-group 1
!
interface Serial1:14
  dialer rotary-group 1
!
interface Serial1:15
  dialer rotary-group 1
!
interface Serial1:16
  dialer rotary-group 1
!
interface Serial1:17
  dialer rotary-group 1
!
interface Serial1:18
  dialer rotary-group 1
!
interface Serial1:19
  dialer rotary-group 1
!
interface Serial1:20
  dialer rotary-group 1
!
interface Serial1:21
  dialer rotary-group 1
!
interface Serial1:22
  dialer rotary-group 1
!
interface Serial1:23
  dialer rotary-group 1
!
interface Group-Async1
  ip unnumbered Loopback0
  encapsulation ppp
  async mode interactive
  peer default ip address pool dialin_pool
  no cdp enable
  ppp authentication chap pap dialin
  group-range 1 96
!
interface Dialer1
  ip unnumbered Loopback0
  no ip mroute-cache
  encapsulation ppp
  peer default ip address pool dialin_pool
  no fair-queue
  no cdp enable
  ppp authentication chap pap dialin
!
router eigrp 10
  network 10.0.0.0
  passive-interface Dialer0
  no auto-summary
!
ip local pool dialin_pool 10.1.2.1 10.1.2.96
ip default-gateway 10.1.1.1
ip classless
!
```

```

dialer-list 1 protocol ip permit
radius-server host 10.1.1.23 auth-port 1645 acct-port 1646
radius-server host 10.1.1.24 auth-port 1645 acct-port 1646
radius-server key cisco
!
line con 0
  login authentication console
line 1 96
  autoselect ppp
  autoselect during-login
  login authentication dialin
  modem DialIn
line aux 0
  login authentication console
line vty 0 4
  login authentication vty
  transport input telnet rlogin
!
end

```

ISDN CAS Examples

This section provides channelized E1 sample configurations for the Cisco AS5200 access server. You can configure the 30 available channels with CAS, channel grouping, or a combination of the two. It includes the following sections:

- Allocating All Channels for CAS
- Mixing and Matching Channels—CAS and Channel Grouping

Allocating All Channels for CAS

The following interactive example configures channels (also known as time slots) 1 to 30 with ear and mouth channel signaling and feature group B support on a Cisco AS5200; it also shows that the router displays informative messages about each time slot. signaling messages are sent in the 16th time slot; therefore, that time slot is not brought up.

```

Router#
%SYS-5-CONFIG_I: Configured from console by console
Router# configure terminal
Enter configuration commands, one per line. End with CNTL/Z.
Router(config)# controller e1 0
Router(config-controller)# cas-group 1 timeslots 1-31 type e&m-fgb
Router(config-controller)#
%DSX0-5-RBSLINEUP: RBS of controller 0 timeslot 1 is up
%DSX0-5-RBSLINEUP: RBS of controller 0 timeslot 2 is up
%DSX0-5-RBSLINEUP: RBS of controller 0 timeslot 3 is up
%DSX0-5-RBSLINEUP: RBS of controller 0 timeslot 4 is up
%DSX0-5-RBSLINEUP: RBS of controller 0 timeslot 5 is up
%DSX0-5-RBSLINEUP: RBS of controller 0 timeslot 6 is up
%DSX0-5-RBSLINEUP: RBS of controller 0 timeslot 7 is up
%DSX0-5-RBSLINEUP: RBS of controller 0 timeslot 8 is up
%DSX0-5-RBSLINEUP: RBS of controller 0 timeslot 9 is up
%DSX0-5-RBSLINEUP: RBS of controller 0 timeslot 10 is up
%DSX0-5-RBSLINEUP: RBS of controller 0 timeslot 11 is up
%DSX0-5-RBSLINEUP: RBS of controller 0 timeslot 12 is up
%DSX0-5-RBSLINEUP: RBS of controller 0 timeslot 13 is up

```

```

%DSX0-5-RBSLINEUP: RBS of controller 0 timeslot 14 is up
%DSX0-5-RBSLINEUP: RBS of controller 0 timeslot 15 is up
%DSX0-5-RBSLINEUP: RBS of controller 0 timeslot 17 is up
%DSX0-5-RBSLINEUP: RBS of controller 0 timeslot 18 is up
%DSX0-5-RBSLINEUP: RBS of controller 0 timeslot 19 is up
%DSX0-5-RBSLINEUP: RBS of controller 0 timeslot 20 is up
%DSX0-5-RBSLINEUP: RBS of controller 0 timeslot 21 is up
%DSX0-5-RBSLINEUP: RBS of controller 0 timeslot 22 is up
%DSX0-5-RBSLINEUP: RBS of controller 0 timeslot 23 is up
%DSX0-5-RBSLINEUP: RBS of controller 0 timeslot 24 is up
%DSX0-5-RBSLINEUP: RBS of controller 0 timeslot 25 is up
%DSX0-5-RBSLINEUP: RBS of controller 0 timeslot 26 is up
%DSX0-5-RBSLINEUP: RBS of controller 0 timeslot 27 is up
%DSX0-5-RBSLINEUP: RBS of controller 0 timeslot 28 is up
%DSX0-5-RBSLINEUP: RBS of controller 0 timeslot 29 is up
%DSX0-5-RBSLINEUP: RBS of controller 0 timeslot 30 is up
%DSX0-5-RBSLINEUP: RBS of controller 0 timeslot 31 is up

```

Mixing and Matching Channels—CAS and Channel Grouping

The following interactive example shows you how to configure an E1 controller to support a combination of CAS and channel grouping. The range of time slots that you allocate must match the time slot allocations that your central office chooses to use. This configuration is rare because of the complexity of aligning the correct range of time slots on both ends of the connection.

Time slots 1 through 15 are assigned to channel group 1. In turn, these time slots are assigned to serial interface 0 and virtual channel group 1 (shown as serial 0:1).

```

AS5200(config)# controller e1 0
Router(config-controller)# channel-group 1 timeslots 1-15
Router(config-controller)#
%LINEPROTO-5-UPDOWN: Line protocol on Interface Serial0:1, changed state to down
%LINK-3-UPDOWN: Interface Serial0:1, changed state to up
%LINEPROTO-5-UPDOWN: Line protocol on Interface Serial0:1, changed state to up

```

Time slots 17 to 31 are configured with CAS:

```

Router(config-controller)# cas-group 2 timeslots 17-31 type e&m-fgb
%LINEPROTO-5-UPDOWN: Line protocol on Interface Serial0:1, changed state to down
Router(config-controller)#
%DSX0-5-RBSLINEUP: RBS of controller 0 timeslot 17 is up
%DSX0-5-RBSLINEUP: RBS of controller 0 timeslot 18 is up
%DSX0-5-RBSLINEUP: RBS of controller 0 timeslot 19 is up
%DSX0-5-RBSLINEUP: RBS of controller 0 timeslot 20 is up
%DSX0-5-RBSLINEUP: RBS of controller 0 timeslot 21 is up
%DSX0-5-RBSLINEUP: RBS of controller 0 timeslot 22 is up
%DSX0-5-RBSLINEUP: RBS of controller 0 timeslot 23 is up
%DSX0-5-RBSLINEUP: RBS of controller 0 timeslot 24 is up
%DSX0-5-RBSLINEUP: RBS of controller 0 timeslot 25 is up
%DSX0-5-RBSLINEUP: RBS of controller 0 timeslot 26 is up
%DSX0-5-RBSLINEUP: RBS of controller 0 timeslot 27 is up
%DSX0-5-RBSLINEUP: RBS of controller 0 timeslot 28 is up
%DSX0-5-RBSLINEUP: RBS of controller 0 timeslot 29 is up
%DSX0-5-RBSLINEUP: RBS of controller 0 timeslot 30 is up
%DSX0-5-RBSLINEUP: RBS of controller 0 timeslot 31 is up
Router(config-controller)#

```

E1 R2 Signaling Procedure

The following procedure configures R2 signaling and customizes R2 parameters on controller E1 2 of a Cisco AS5300 access server. In most cases, the same R2 signaling type is configured on each E1 controller.

- Step 1** Enter global configuration mode using the **configure terminal** command:

```
as5300# configure terminal
Enter configuration commands, one per line. End with CNTL/Z.
```

- Step 2** Specify the E1 controller that you want to configure with R2 signaling using the **controller e1 number** global configuration command. A controller informs the access server how to distribute or provision individual time slots for a connected channelized E1 line. You must configure one E1 controller for each E1 line.

```
as5300(config)# controller e1 2
```

- Step 3** Configure CAS with the **cas-group channel timeslots range type signal** command. The signaling type forwarded by the connecting telco switch must match the signaling configured on the Cisco AS5300 access server. The Cisco IOS configuration options are **r2-analog**, **r2-digital**, or **r2-pulse**.

```
as5300(config-controller)# cas-group 1 timeslots 1-31 type ?
e&m-fgb          E & M Type II FGB
e&m-fgd          E & M Type II FGD
e&m-immediate-start E & M Immediate Start
fxs-ground-start FXS Ground Start
fxs-loop-start   FXS Loop Start
p7              P7 Switch
r2-analog       R2 ITU Q411
r2-digital      R2 ITU Q421
r2-pulse        R2 ITU Supplement 7
sas-ground-start SAS Ground Start
sas-loop-start  SAS Loop Start
```

The following example specifies R2 ITU Q421 digital line signaling (**r2-digital**). This example also specifies R2 compelled register signaling and provisions the ANI ADDR option.

```
as5300(config-controller)# cas-group 1 timeslots 1-31 type r2-digital r2-compelled ani
as5300(config-controller)#
%D SX0-5-RBSLINEUP: RBS of controller 0 timeslot 1 is up
%D SX0-5-RBSLINEUP: RBS of controller 0 timeslot 2 is up
%D SX0-5-RBSLINEUP: RBS of controller 0 timeslot 3 is up
%D SX0-5-RBSLINEUP: RBS of controller 0 timeslot 4 is up
%D SX0-5-RBSLINEUP: RBS of controller 0 timeslot 5 is up
%D SX0-5-RBSLINEUP: RBS of controller 0 timeslot 6 is up
%D SX0-5-RBSLINEUP: RBS of controller 0 timeslot 7 is up
%D SX0-5-RBSLINEUP: RBS of controller 0 timeslot 8 is up
%D SX0-5-RBSLINEUP: RBS of controller 0 timeslot 9 is up
%D SX0-5-RBSLINEUP: RBS of controller 0 timeslot 10 is up
%D SX0-5-RBSLINEUP: RBS of controller 0 timeslot 11 is up
%D SX0-5-RBSLINEUP: RBS of controller 0 timeslot 12 is up
%D SX0-5-RBSLINEUP: RBS of controller 0 timeslot 13 is up
%D SX0-5-RBSLINEUP: RBS of controller 0 timeslot 14 is up
%D SX0-5-RBSLINEUP: RBS of controller 0 timeslot 15 is up
%D SX0-5-RBSLINEUP: RBS of controller 0 timeslot 17 is up
%D SX0-5-RBSLINEUP: RBS of controller 0 timeslot 18 is up
%D SX0-5-RBSLINEUP: RBS of controller 0 timeslot 19 is up
%D SX0-5-RBSLINEUP: RBS of controller 0 timeslot 20 is up
%D SX0-5-RBSLINEUP: RBS of controller 0 timeslot 21 is up
%D SX0-5-RBSLINEUP: RBS of controller 0 timeslot 22 is up
```

```
%DSX0-5-RBSLINEUP: RBS of controller 0 timeslot 23 is up
%DSX0-5-RBSLINEUP: RBS of controller 0 timeslot 24 is up
%DSX0-5-RBSLINEUP: RBS of controller 0 timeslot 25 is up
%DSX0-5-RBSLINEUP: RBS of controller 0 timeslot 26 is up
%DSX0-5-RBSLINEUP: RBS of controller 0 timeslot 27 is up
%DSX0-5-RBSLINEUP: RBS of controller 0 timeslot 28 is up
%DSX0-5-RBSLINEUP: RBS of controller 0 timeslot 29 is up
%DSX0-5-RBSLINEUP: RBS of controller 0 timeslot 30 is up
%DSX0-5-RBSLINEUP: RBS of controller 0 timeslot 31 is up
```



Note The actual R2 CAS is configured on the 16th time slot, which is why the time slot does not come up in the example output. For a description of the supported R2 signaling options, see the **cas-group** command for the E1 controller in the *Cisco IOS Dial Services Command Reference* publication.

Step 4 Customize some of the E1 R2 signaling parameters with the **cas-custom** *channel* controller configuration command. This example specifies the default R2 settings for Argentina. For custom options, see the **cas-custom** command in the *Cisco IOS Dial Services Command Reference* publication.

```
as5300(config-controller)# cas-custom 1
as5300(config-ctrl-cas)# ?
CAS custom commands:
  ani-digits          Expected number of ANI digits
  answer-signal      Answer signal to be used
  caller-digits       Digits to be collected before requesting CallerID
  category           Category signal
  country            Country Name
  default            Set a command to its defaults
  dnis-digits        Expected number of DNIS digits
  exit               Exit from cas custom mode
  invert-abcd        invert the ABCD bits before tx and after rx
  ka                 KA Signal
  kd                 KD Signal
  metering           R2 network is sending metering signal
  nc-congestion      Non Compelled Congestion signal
  no                 Negate a command or set its defaults
  request-category   DNIS digits to be collected before requesting category
  unused-abcd        Unused ABCD bit values

as5300(config-ctrl-cas)# country ?
  argentina          Argentina
  australia          Australia
  brazil             Brazil
  china              China
  colombia           Colombia
  .
  .
  .
as5300(config-ctrl-cas)# country argentina ?
  use-defaults      Use Country defaults
  <cr>

as5300(config-ctrl-cas)# country argentina use-defaults
```



Note We highly recommend that you specify the default settings of your country. To display a list of supported countries, enter the **country?** command. The default setting for all countries is ITU.

R1 Modified Signaling Configuration—Cisco AS5200

The following example shows a configuration sample for R1 modified signaling on a Cisco AS5200 access sever, using an E1 interface:

```

version 11.3
service timestamps debug datetime msec
no service password-encryption
!
hostname router
!
enable secret 5 $1$YAaG$L0jTcQ.nMH.gpFYXaOU5c.
!
no modem fast-answer
ip host dirt 223.255.254.254
ip multicast rpf-check-interval 0
isdn switch-type primary-dms100
!
!
controller E1 0
  clock source line primary
  cas-group 1 timeslots 1-15,17-31 type r1-modified ani-dnis
!
controller E1 1
  clock source line secondary
  cas-group 1 timeslots 1-15,17-31 type r1-modified ani-dnis
!
controller E1 2
  clock source internal
!
controller E1 3
  clock source internal
!
interface Ethernet0
  ip address 1.19.36.7 255.255.0.0
  no ip mroute-cache
!
interface FastEthernet0
  no ip address
  no ip route-cache
  no ip mroute-cache
  shutdown
!
interface Group-Async1
  ip unnumbered Ethernet0
  encapsulation ppp
  dialer in-band
  dialer idle-timeout 480
  dialer-group 1
  async dynamic address
  async mode interactive

```

```

peer default ip address pool DYNAMIC
no fair-queue
no cdp enable
group-range 1 108
!
router igrp 200
network 1.0.0.0
network 223.255.254.0
!
no ip classless
ip route 0.0.0.0 0.0.0.0 Ethernet0
logging source-interface Ethernet0
!
line con 0
exec-timeout 0 0
line 1 108
exec-timeout 0 0
modem InOut
transport input all
line aux 0
line vty 0 4
!
end

```

R1 Modified Signaling Configuration—Cisco AS5800

The following is a sample R1 modified signaling configuration in Taiwan:

```

service timestamps debug datetime msec
no service password-encryption
!
hostname router
!
enable secret 5 $1$YaaG$L0jTcQ.nMH.gpFYXaOU5c.
!
no modem fast-answer
ip host dirt 223.255.254.254
ip multicast rpf-check-interval 0
isdn switch-type primary-dms100
!
!
controller T1 1/1/0
framing esf
linecode b8zs
cablelength short 133
pri-group timeslots 1-24
fdl att
!
controller T1 1/1/1
framing esf
linecode b8zs
cablelength short 133
cas-group 1 timeslots 1-24 type r1-modified
fdl att
!

```

```
controller T1 1/1/2
  framing esf
  linecode b8zs
  cablelength short 133
  pri-group timeslots 1-24
  fdl att
!
controller T1 1/1/3
  framing esf
  linecode b8zs
  cablelength short 133
  pri-group timeslots 1-24
  fdl att
!
```