



Configuring AppleTalk Remote Access

This chapter describes how to configure your router to act as an AppleTalk Remote Access (ARA) server. It includes the following main sections:

- ARA Overview
- ARA Configuration Task List
- Making ARA Connections
- Monitoring an ARA Server
- Monitoring the AppleTalk Network
- Troubleshooting ARA Connections
- ARA Configuration and Connection Examples

This chapter does not describe how to configure or use the client Macintosh. See the Apple Computer, Inc. *Apple Remote Access Client User's Guide* and the *Apple Remote Access Personal Server User's Guide* for information about how to set up and use the ARA software on your Macintosh.

For a complete description of the commands in this chapter, see the *Cisco IOS Dial Services Command Reference* publication. To locate documentation of other commands that appear in this chapter, use the command reference master index or search online.

ARA Overview

The Cisco implementation of ARA gives Macintosh users direct access to information and resources in remote AppleTalk networks over standard telephone lines. For example, if you have a PowerBook at home and need to get a file from your Macintosh at the office, ARA software can make the connection between your home and office computers over telephone lines.

You can configure your router to act as an ARA server by enabling AppleTalk and ARA protocol on physical terminal (TTY) or virtual terminal lines. Configuring your router to act as an ARA server allows remote Macintosh users to dial in, become a network node, and connect to devices on other networks. ARA protocol support is transparent to the Macintosh end user. Macintosh users can also use Serial Line Internet Protocol (SLIP) to access remote IP network resources and PPP to access both AppleTalk and IP resources.

The following Macintosh and Cisco IOS software support is required for ARA connectivity:

- Macintosh running ARA software and a connection control language (CCL) script.
- Router configured as an ARA server.

Figure 107 shows how your router can act as an ARA server between remote Macintosh computers (in Figure 107, a Power Macintosh and a PowerBook) and devices on another network.

Figure 107 ARA Configuration Overview

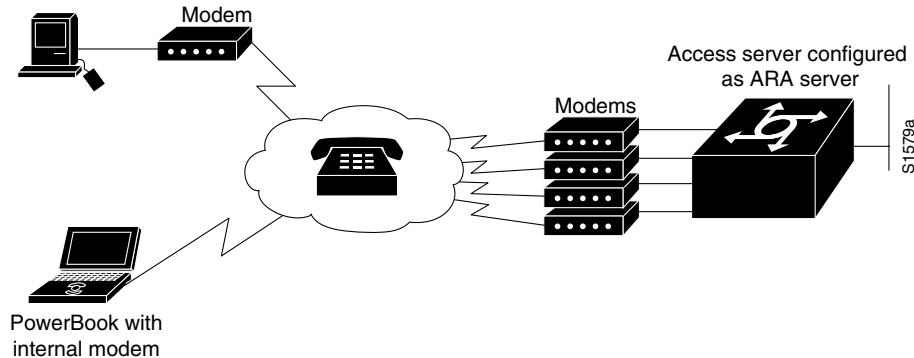

ARA Configuration Task List

To set up the Cisco IOS software to act as an ARA server, perform the following tasks:

- Connecting Cables (Required)
- Configuring the Line and the Modem (Required)
- Configuring ARA (Required)
- Configuring ARA to Automatically Start Up (Optional)
- Configuring ARA Security (Optional)
- Connecting to an AppleTalk Network from a Client Running a Different Virtual Terminal Protocol (Optional)

To enable asynchronous callback to ARA clients, see the section “Call Back ARA Clients” in the “Configuring Asynchronous Callback” chapter in this publication.

To enable remote clients running PPP to dial in and access AppleTalk resources on a network, you must configure AppleTalk Control Protocol. Protocol (ATCP). To configure ATCP, see the section “Configure AppleTalk-PPP” in the chapter “Configuring Asynchronous PPP and SLIP” in this publication.

The section “Making ARA Connections” later in this chapter provides connection examples. The section “Troubleshooting ARA Connections” provides troubleshooting help. The section “ARA Configuration and Connection Examples” provides configuration examples.

Connecting Cables

Figure 108 shows how to connect a Macintosh using internal and external modems.

Figure 108 ARA Server Cabling and Connections

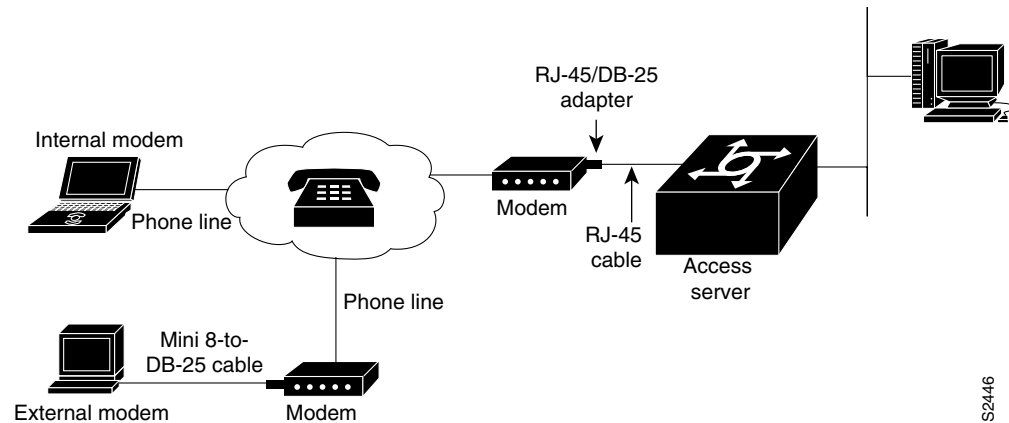

Use the MMOD version of the RJ-45-to-DB-25 adapter (labeled “Modem” if the adapter is from Cisco) to connect a “rolled” RJ-45 cable from the router to the modem. Use a high-speed modem cable with hardware flow control to connect a modem to your Macintosh (see the user documentation for your modem for more specific information).

Some Cisco access servers have internal modems, such as the Cisco AS5800 and Cisco AS5300. Therefore there are no modem cables for you to connect.

For more information about connecting cables, see the installation and configuration or product user guide that came with your router.

Configuring the Line and the Modem

To configure the line, perform the following steps:

- Step 1** Specify the maximum common line speed for the modem and the access server. The access server supports 4x compression of data, so you can typically use the speeds shown in the following list:
- 115200 bits per second (bps) for use with modems that support a transmission rate of 28800
 - 57600 bps for use with modems that support a transmission rate of 14400
 - 38400 bps for use with modems that support a transmission rate of 9600



Note See your modem guide to ensure that the modem can support these maximum line speeds.

- Step 2** Set hardware flow control—Use the **flowcontrol hardware** command to enable hardware flow control.



Note The Cisco IOS software does not support modems that do not support hardware flow control.

Step 3 Specify your modem control parameters—Use the **modem inout** command to configure the line for both incoming and outgoing calls, or use the **modem dialin** command to configure the line for incoming calls only.

Step 4 Configure security on your dial-in lines—Use the **aaa new-model** command to enable the authentication, authorization, and accounting (AAA) process on the router, the **aaa authentication arap** command to create an authentication list, and the **arap authentication** command to apply the authentication list to a line or set of lines configured for ARA.

For more information about configuring lines and modem control, see the chapter “Configuring Modem Support and Asynchronous Devices” in this publication. For information about configuring security, see the *Cisco IOS Security Configuration Guide*.



Note The **autobaud** command is not supported with ARA and should never be used.

Configuring ARA

To allow ARA connections to pass through the access server or router, use the following commands, beginning in global configuration mode:

	Command	Purpose
Step 1	appletalk routing	Enables AppleTalk. ¹
Step 2	arap network <i>[network-number]</i> <i>[zone-name]</i>	Creates a new network or zone for ARA clients when they dial in. The <i>network-number</i> argument must be a unique network number.
Step 3	appletalk send-rtmps	In interface configuration mode, ensures that a new internal network is advertised by enabling the Routing Table Maintenance Protocol (RTMP).
Step 4		You need to configure an AppleTalk interface using the discovery mode in the Cisco IOS software. To do so, an interface on the router must be connected to a network that has at least one other router configured for AppleTalk.
Step 5	appletalk routing	Returns to global configuration mode and turns on AppleTalk routing.
Step 6	line [tty aux vty] <i>line-number</i> <i>[ending-line-number]</i>	Enters line configuration mode.
Step 7	arap enable	Enables ARA on a line.

1. For more information about configuring AppleTalk, see the chapter “Configuring AppleTalk” in the *Cisco IOS AppleTalk and Novell IPX Configuration Guide*.

If you discover that the AppleTalk network already exists when you get to Step 4, the zone and cable range must match the existing configuration. To identify existing cable ranges and zone names, configure the Cisco IOS software for discovery mode. You must manually configure an AppleTalk interface on a segment for which there are no AppleTalk routers. For more information, see the chapter “Configuring AppleTalk” in the *Cisco IOS AppleTalk and Novell IPX Configuration Guide*.

Configuring ARA to Automatically Start Up

Refer to this section after you have configured AppleTalk routing, created an internal ARA network or zone, and enabled ARA. At this point, you can enable optional tasks.

To configure the Cisco IOS software to allow an ARA session to start automatically, use the following commands beginning in global configuration mode:

	Command	Purpose
Step 1	<code>autoselect {arap ppp slip during-login}</code>	Configures a line to automatically start an ARA session.
Step 2	<code>line x</code>	Enters line configuration mode; (x = the line you want to configure is Step 3).
Step 3	<code>arap dedicated</code>	Enters line configuration mode and dedicate a line to function only as an ARA connection.
Step 4	<code>arap timelimit [minutes]</code>	Sets the maximum length of an ARA session for a line. The default is to have unlimited length connections.
Step 5	<code>arap warningtime [minutes]</code>	Sets when a disconnect warning message is displayed, in number of minutes before the line is disconnected. This command is valid only when a session time limit is set.

The **autoselect** command permits the router to start an ARA session automatically when it detects the start character for an ARAP packet. The Cisco IOS software detects either a Return character, which is the start character for an EXEC session, or the start character for the ARA protocol. By entering the **autoselect** command with the **during-login** keyword, you can display the username or password prompt without pressing the Return key. While the username or password prompts are displayed, you can choose to answer these prompts or to start sending packets from an autoselected protocol.

Normally a router avoids line and modem noise by clearing the initial data received within the first 1 or 2 seconds. However, when the autoselect PPP feature is configured, the router flushes characters initially received and then waits for more traffic. This flush causes timeout problems with applications that send only one carriage return. To ensure that the input data sent by a modem or other asynchronous device is not lost after line activation, enter the **flush-at-activation** line configuration command.

For information about using ARA with TACACS, Extended TACACS, and AAA/TACACS+, see the section “Configuring ARA Security” in this chapter, and the *Cisco IOS Security Configuration Guide*.



Note

When you use the autoselect function, the activation character should be set to the default, Return, and exec-character-bits to 7. If you change these defaults, the application cannot recognize the activation request.

To customize the AppleTalk configuration even further, you can perform the following additional tasks:

- Disable checksum generation and verification
- Configure MacIP

For more information about these and other tasks you can perform to customize your AppleTalk configuration, see the chapter “Configuring AppleTalk” in the *Cisco IOS AppleTalk and Novell IPX Configuration Guide*.

Configuring ARA Security

The following three types of security can be used with ARA:

- ARA Server Security, including required manual password entry, limited network visibility, and no guest access.
- Local or Remote Security Database, including username and password authentication and access lists.
- TACACS and TACACS+ Security for ARA, including TACACS, TACACS+/AAA, and Kerberos.

The following sections describe these tasks. See the *Cisco IOS Security Command Reference* for information about commands listed in these tasks.

ARA Server Security

This section describes the following security features that are specific to the ARA protocol:

- Requiring Manual Password Entry
- Limiting Network Visibility
- Disallowing Guests

Requiring Manual Password Entry

You can control access by requiring users to enter their password manually at the time they log in. To force manual password entry, use the following command in line configuration mode:

Command	Purpose
<code>arap require-manual-password</code>	Requires manual password entry.

Limiting Network Visibility

You can control Macintosh access to zones and networks by using **arap** commands to reference Access Control Lists configured using AppleTalk **access-list** commands.

To control which zones the Macintosh user can see, use the following command in line configuration mode:

Command	Purpose
<code>arap zonelist zone-access-list-number</code>	Limits the zones the Macintosh user sees.

To control traffic from the Macintosh to networks, use the following command in line configuration mode:

Command	Purpose
<code>arap net-access-list <i>net-access-list-number</i></code>	Controls access to networks.

Disallowing Guests

A guest is a user that connects to the network without the need to give a name or a password. To prohibit Macintosh guests from logging in through the router, use the following command in line configuration mode. Use the optional **if-needed** argument to allow users to log in as guests if they are already authenticated with a username or password.

Command	Purpose
<code>arap noguest [<i>if-needed</i>]</code>	Prohibits guests from logging in to the ARA network.



Caution

Do not use the **arap noguest** command if you are using modified CCL scripts and the **login tacacs** command.

Local or Remote Security Database

To prevent unauthenticated users from accessing your network resources, you configure a username and password database. This database can be local on the router or can be stored on a remote security server (a PC or UNIX computer set up with a security database). Perform the tasks in the following sections to configure the Cisco IOS software to support either local or remote authentication:

- Configuring Local Username Authentication (As Required)
- Enabling Remote TACACS or TACACS+ Server Authentication (As Required)

Configuring Local Username Authentication

To configure internal username authentication, use the following command in global configuration mode. Enter this information for each supported user.

Command	Purpose
<code>username <i>name</i> [<i>user-maxlinks link-number</i>] <i>password secret</i></code>	<p>Specifies a username and password. Optionally, you can specify the maximum number of connections a user can establish.</p> <p>To use the user-maxlinks keyword, you must also use the aaa authorization network default local command, and PPP encapsulation and name authentication on all the interfaces the user will be accessing.</p>

When users try to log in to the access server, username and password prompts require them to authenticate themselves before they can have access to the router or the network.

Enabling Remote TACACS or TACACS+ Server Authentication

To enable the Cisco IOS software to use a remote TACACS or TACACS+ authentication database, use the following commands in global configuration mode:

	Command	Purpose
Step 1	<code>tacacs-server host {hostname ip-address}</code>	Specifies the IP address or the host name of the remote TACACS+ server host. This host is typically a UNIX system running TACACS+ software.
Step 2	<code>tacacs-server key shared-secret-text-string</code>	Specifies a shared secret text string used between the router and the TACACS+ server. The router and TACACS+ server use this text string to encrypt passwords and exchange responses.

After you specify these commands in the Cisco IOS software, you must populate the remote username database to all users to whom you want to provide network access. When users try to log in to the router, username and password prompts require them to authenticate themselves before they can have access to the router or the network.

TACACS and TACACS+ Security for ARA

You can prevent unauthenticated users from accessing your network resources using the following security mechanisms:

- TACACS and AAA/TACACS+ user authentication, with username and password information stored on a TACACS or TACACS+ server
- Kerberos, which is configured through the AAA facility

For more information about each of these security mechanisms, see the *Cisco IOS Security Configuration Guide*.

Perform the tasks in the following sections to configure TACACS and TACACS+ security to authenticate clients that are using ARA to dial in:

- Enabling Standard and Extended TACACS for ARA Authentication (Required)
- Enabling AAA/TACACS+ for ARA Authentication (Required)
- Modifying Scripts to Support a Standard EXEC Security Dialog (Optional)—This modification is only necessary if you are running Standard TACACS on both your router and your TACACS server.

Enabling Standard and Extended TACACS for ARA Authentication

To use extended TACACS, you must already have set up an extended TACACS server using the Cisco extended TACACS server software, available from the ftp.cisco.com directory. Refer to the README file in this directory for more information. The following two authentication methods are used with standard TACACS:

- You issue the **arap use-tacacs** command. The remote user logs in by entering the appropriate username at the ARA username prompt and password at the password prompt.
- You issue the **arap use-tacacs** command and the **single-line** keyword. The remote user logs in by entering *username*password* at the ARA username prompt, and **arap** at the password prompt.

**Note**

The **arap use-tacacs** command provides TACACS security without the need to modify CCL scripts and respond to dialog boxes. The use of scripts is still a supported feature, and is described in the section “Modifying Scripts to Support a Standard EXEC Security Dialog” later in this chapter.

To configure the router to authenticate using TACACS, use the following commands in line configuration mode:

	Command	Purpose
Step 1	arap use-tacacs [single-line]	Enables TACACS under ARA.
Step 2	login tacacs	Enables login authentication using TACACS.

For an example of enabling TACACS for ARA authentication, see the section “ARA Configuration and Connection Examples” at the end of this chapter.

Enabling AAA/TACACS+ for ARA Authentication

To enable TACACS+ authentication for ARA sessions, use the following commands beginning in global configuration mode:

	Command	Purpose
Step 1	aaa new-model	Enables the AAA function in the Cisco IOS software.
Step 2	aaa authentication arap login { default <i>list-name</i> } <i>method1</i> [...] <i>method4</i> }	Creates an authentication list that you later apply to lines configured for ARA sessions or log in to the router.
Step 3	line [tty] <i>line-number</i> [<i>ending-line-number</i>]	Enters line configuration mode.
Step 4	arap authentication { default <i>list-name</i> }	Applies an ARA authentication list to lines configured for ARA.
Step 5	login authentication { default <i>list-name</i> }	Applies a login authentication list to lines that users can log in to.

Modifying Scripts to Support a Standard EXEC Security Dialog

This section describes how to modify your CCL script to work with TACACS security and how to configure a line to use a TACACS server for user authentication.

**Caution**

Because of the underlying structure of the ARA protocol, modem-layer error control is disabled during the exchange of username and password. This condition makes the exchange highly susceptible to line noise, especially at higher baud rates enabled by V.34 modems. For this reason, Cisco does not recommend the use of modified scripts and encourage users to either upgrade to later versions of TACACS or to use the **arap use-tacacs single-line** command.

For information on how to use TACACS without modifying scripts, see the section “Enabling Standard and Extended TACACS for ARA Authentication” earlier in this chapter. For information about the **arap** commands, see the *Cisco IOS Dial Services Command Reference* publication.

If you are currently using modified CCL scripts and want to migrate to nonmodified scripts, see the section “Modified and Unmodified CCL Scripts” later in this chapter for information on how to use both in the same environment.

For several popular modems, Cisco provides CCL files that you can use as examples to modify your CCL scripts to support TACACS security. This section explains how to use the CCL files provided by Cisco with TACACS security.

For more information about standard modem initialization scripts, see the appendix “Configuring Modem Support and Chat Scripts” in the *Cisco IOS Dial Services Command Reference* publication. Cisco recommends using the ARA Modem Toolkit provided through the AppleTalk Programmers and Developers Association (APDA); it provides both syntax checking and a script tester.

The Macintosh client uses ARA CCL scripts to establish point-to-point links with the modem to the AppleTalk network. When the connection has been established, the script ends and ARA is activated. TACACS authentication occurs after the connection is established and the ARA script ends, but before the ARAP protocol becomes active.

Insert TACACS logic just before the end of a script. The CCL TACACS logic performs the following user authentication tasks:

1. When the “Username:” prompt is received from the router, the TACACS server queries the user for a username, as shown in Figure 109.

Figure 109 TACACS Login Screen on the Macintosh Computer

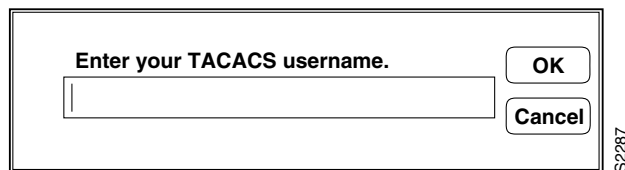

2. When the “Password:” prompt is received from the router, the TACACS server queries the user for a password, as shown in Figure 110.

Figure 110 TACACS Password Screen on the Macintosh Computer

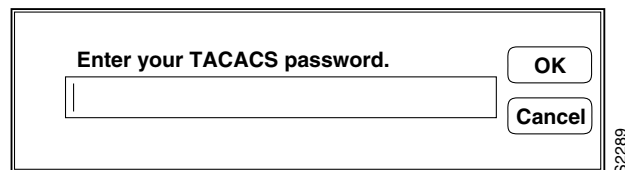

3. After a successful login, indicated by an EXEC prompt, the **arap** EXEC command is executed.
4. The script ends and ARA is activated on the client.

CCL scripts control logical flow by jumping to labels. The labels are the numbers 1 through 128 and are not necessarily in sequential order in script files. The TACACS logic in the Cisco IOS software CCL files has label numbers from 100 through 127. In most environments, you can copy the complete TACACS logic from a sample file.

To create a new TACACS CCL file, perform the following steps:

Step 1 Copy the TACACS logic from a sample CCL script into the new CCL script.

In most cases, you can insert the TACACS logic at the appropriate place in your CCL script. The one case that requires extra attention is when the original CCL script has labels that conflict with the logic in the new file. The labels must be resolved on a case-by-case basis, usually by changing the label numbers used in the original CCL script. Be sure to read the manual that comes with the ARA Modem Toolkit before beginning.

Step 2 Locate the logical end of the CCL script and insert the **jump 100** command.

You can locate the logical end of the script by following its flow. Most scripts have the following basic structure:

- Initialize the modem
- Dial the number
- Exit

The characteristic logical end of the script is as follows:

```
@label N
! N is any integer between 1 and 128.
if ANSWER N+1
! If we're answering the phone, jump directly
! to the label N+1.
pause 30
! We're not answering the phone, therefore we
! must be calling. Wait three seconds for the
! modems to sync up.
@label N+1
exit 0
! Quit and start up ARA.
```

It is common in this case to replace “pause 30” with “jump 100.” In fact, this replacement is usually the only change made to the logic of the original CCL script.

See the chapter “Configuring Modem Support and Asynchronous Devices” in this publication for information about configuring a line to support your modem.

Enabling Kerberos Security for ARA Authentication

You can use Kerberos as an authentication method within ARA sessions. To do so, you configure Kerberos using the AAA/TACACS+ facility in the Cisco IOS software.

To enable Kerberos security, use the following commands in global configuration mode:

	Command	Purpose
Step 1	<code>kerberos local-realm {kerberos-realm}</code>	Defines the name of the Kerberos realm in which the router is located.
Step 2	<code>kerberos realm {dns-domain dns-host} kerberos-realm</code>	Defines the DNS domain of the Kerberos realm in which the router is located.
Step 3	<code>show kerberos creds</code>	Displays the contents of your credentials cache.
Step 4	<code>clear kerberos creds</code>	Deletes the contents of your credentials cache.

For more information about Kerberos authentication, see the *Cisco IOS Security Configuration Guide*.

Using Access Lists to Control Access to AppleTalk Networks

An access list is a list of AppleTalk network numbers or zones that is maintained by the Cisco IOS software and used to control access to or from specific zones or networks. For more information about AppleTalk access lists, see the section “Control Access to AppleTalk Networks” in the chapter “Configuring AppleTalk” in the *Cisco IOS AppleTalk and Novell IPX Configuration Guide*.

Connecting to an AppleTalk Network from a Client Running a Different Virtual Terminal Protocol

ARA can run on any point-to-point link, such as a Public Switched Telephone Network (PSTN) or an X.25 WAN. This permits remote Macintosh users to dial in to a remote network and access AppleTalk services (such as file sharing and printing). For example, you can enable a Macintosh client on the remote side of an X.25 WAN to connect to an AppleTalk network through the router. To do so, you configure a virtual terminal line on the router so that the client sees one of two scenarios:

- A client clicks **Connect** in an ARA application dialog box and connects to a virtual terminal line on the router. ARA automatically starts up on the outgoing virtual terminal line, and the client is connected to the AppleTalk network. This section describes how to configure the Cisco IOS software for this process.
- A client clicks **Connect** in an ARA application dialog box and connects directly through the router to the AppleTalk network. This process is described in the section “Configure Tunneling of SLIP, PPP, or ARA” in the chapter “Configuring Protocol Translation and Virtual Asynchronous Devices” in this publication.

To enable ARA on virtual terminal lines and enable clients running different virtual terminal protocols to connect to an AppleTalk network through the router, use the following commands beginning in global configuration mode. The first four steps are required. The next eight steps are optional.

	Command	Purpose
Step 1	<code>appletalk routing</code>	Turns on AppleTalk routing.
Step 2	<code>arap network [network-number] [zone-name]</code>	Creates an internal AppleTalk network.
Step 3	<code>line vty line-number [ending-line-number]</code>	Enters line configuration mode.
Step 4	<code>arap enable</code>	Enables ARA on a line.

	Command	Purpose
Step 5	<code>autocommand arap</code>	Configures automatic protocol startup.
Step 6	<code>arap dedicated</code>	Sets a dedicated ARA line.
Step 7	<code>arap timelimit [minutes]</code>	Sets the session time limit.
Step 8	<code>arap warningtime [minutes]</code>	Sets the disconnect warning time.
Step 9	<code>arap noguest</code>	Disallows guests.
Step 10	<code>arap require-manual-password</code>	Requires manual password entry.
Step 11	<code>arap zonelist zone-access-list-number</code>	Limits the zones the Macintosh user sees.
Step 12	<code>arap net-access-list net-access-list number</code>	Controls access to networks.

Making ARA Connections

If you are a Macintosh user, you can use ARA to connect to an AppleTalk network through a Cisco access server. The Cisco IOS Release 10.2 and later software support ARA 2.0 and ARA 1.0 so that you can remotely dial in through asynchronous network devices using ARA to access AppleTalk services (such as file sharing and printing) elsewhere on the network. For example, you can dial in from an X.25 network and connect to an AppleTalk network through a router. To enable ARA and dial-in access, configure a virtual terminal line on the router. You can also configure ARA on TTY lines.

Because there are no user commands for connecting to the network from your Macintosh client, the process is not described in this publication. To start a connection in most ARA client packages, you click the **Connect** button from within the client software.

Monitoring an ARA Server

To display information about a running ARA connection, use the following command in EXEC mode (reached by entering the **enable** command and a password):

Command	Purpose
<code>show arap [line-number]</code>	Displays information about a running ARA connection.

The **show arap** command with no arguments displays a summary of ARA traffic since the router was last booted. The **show arap** command with a specified line number displays information about the connection on that line.

Monitoring the AppleTalk Network

The Cisco IOS software provides several commands that you can use to monitor an AppleTalk network. In addition, you can use Apple Computer's Inter-Poll, which is a tool to verify that a device is configured and operating properly. Use the commands described in this section to monitor an AppleTalk network using both Cisco IOS software commands and Inter-Poll.

To monitor the AppleTalk network, use any of the the following commands in EXEC mode:

Command	Purpose
<code>show appletalk arp</code>	Lists the entries in the AppleTalk ARP table.
<code>show appletalk interface [brief] [type number]</code>	Displays AppleTalk-related interface settings.
<code>show appletalk macip-clients</code>	Displays the status of all known MacIP clients.
<code>show appletalk macip-servers</code>	Displays the status of MacIP servers.
<code>show appletalk macip-traffic</code>	Displays statistics about MacIP traffic.
<code>show appletalk traffic</code>	Displays the statistics about AppleTalk protocol traffic, including MacIP traffic.
<code>show appletalk zone [zone-name]</code>	Displays the contents of the zone information table.

Troubleshooting ARA Connections

Use ARA debugging enhancements to troubleshoot one or more asynchronous lines on an access server. These enhancements are supported on all Macintosh terminals and all Cisco routers and access servers that support the AppleTalk software feature set.

Allowing users to specify a single line via an additional parameter for troubleshooting produces the following benefits:

- Focused results—Users get only the information they need.
- Reduced server load—Heavily loaded servers are subject to developing ARAP problems which need to be fixed by debugging. However, debugging itself increases the server work load. By focusing on specific lines, the impact of debugging activity on the server is minimized.
- Targeting flexibility—By being able to debug on just the lines in a group of lines, users can solve problems in rotary groups in which there is no way to specify which line or group of lines a remote user will be assigned.

To enable ARAP debugging, use the following commands, beginning in EXEC mode:

	Command	Purpose
Step 1	<code>debug arap {internal memory mnp4 v42bis}</code>	Enters debug mode and specifies the type of the debug. To debug internal ARA packets, specify internal . To debug the memory allocated to ARA, specify memory . To debug the serial protocol, specify mnp4 . To debug compression, specify v42bis .
Step 2	<code>debug arap internal [linenum [aux console tty vty]]</code>	Replaces the <i>linenum</i> variable with a single line number. Specifies the target for the debug. Specify aux to debug an auxiliary line, console to debug a primary terminal line, tty to debug a physical terminal asynchronous line, or vty to debug a virtual terminal line.

To verify if the debug level and target are set correctly, enter the **show debug** command:

```
router# show debug
router# show debug
AppleTalk Remote Access:
ARAP MNP4 debugging is on for line 7
```

ARAP Debugging Examples

The following example sets ARAP debugging in memory mode on line 7. The **show debug** command confirms the configuration.

```
router# debug arap mn 7
  ARAP MNP4 debugging is on for line 7
router# debug arap mn 8
  ARAP MNP4 debugging is on for line 8
router# debug arap mn 9
  ARAP MNP4 debugging is on for line 9
router# show debug
AppleTalk Remote Access:
  ARAP MNP4 debugging is on for line 7
  ARAP MNP4 debugging is on for line 8
  ARAP MNP4 debugging is on for line 9
```

**Note**

You can debug several lines (for example, lines in a rotary), but you must turn on debugging one line at a time.

The following example sets ARAP debugging in internal mode on line 6, memory mode on line 10, and V.42bis compression mode on line 6. The **show debug** command confirms the configuration.

```
router# debug arap in 6
  ARAP internal packet debugging is on for line 6
router# debug arap me 10
  ARAP memory debugging is on for line 10
router# debug arap v 6
  ARAP V.42bis debugging is on for line 6
router# show debug
AppleTalk Remote Access:
  ARAP V.42bis debugging is on for line 6
  ARAP internal packet debugging is on for line 6
  ARAP memory debugging is on for line 10
```

The following example sets ARAP debugging for each mode in succession and for all lines. The **show debug** command confirms the configuration.

```
router# debug arap mnp4
  ARAP MNP4 debugging is on
router# debug arap internal
  ARAP internal packet debugging is on
router# debug arap v42bis
  ARAP V.42bis debugging is on
router# debug arap memory
  ARAP memory debugging is on
router# show debug
AppleTalk Remote Access:
  ARAP MNP4 debugging is on
  ARAP V.42bis debugging is on
  ARAP internal packet debugging is on
  ARAP memory debugging is on
router#
```

The following example sets all debugging (including ARAP debugging) for all modes and for all lines. The **show debug** command confirms the configuration. Note that turning on all debugging utilities can slow down performance.

```
router# debug all
This may severely impact network performance. Continue? [confirm]y
All possible debugging has been turned on
router# show debug
"debug all" is in effect.
```

The following example turns off ARAP debugging. The **show debug** command confirms the configuration.

```
router#
router# undebg all
All possible debugging has been turned off
router# show debug
router#
```

The following example shows debug output for two lines, 2 and 4:

```
ARAP MEM TTY 4: arap_getbuffer 94745C
ARAP MEM TTY 4: arap_datagram_done 7BD324
MNP4 TTY 4:mnp4_input()
MNP4 TTY 2:mnp4_input()
ARAP MEM TTY 2: arap_getbuffer 7BD158
MNP4 TTY 2:Rcv LA Nr[31] Nk[08]
ARAP MEM TTY 2: arap_datagram_done 7BD6BC
MNP4 TTY 4:mnp4_input()
ARAP SMARTBUF TTY 2: ring end 936C62, start 934ED4, need 58 bytes
ARAP SMARTBUF TTY 2: new seq 161

ARAP TTY 4: Received TICKLE
ARAP TTY 4: ----- ACKing 125 -----
ARAP SMARTBUF TTY 2: ring end 936C28, start 934ED4, need 58 bytes
ARAP SMARTBUF TTY 2: new seq 160
ARAP SMARTBUF TTY 2: ring end 9342B4, start 9322EC, need 64 bytes
ARAP SMARTBUF TTY 2: new seq 144
ARAP SMARTBUF TTY 2: search...
ARAP SMARTBUF TTY 2: search...
0 ddp; trailing; 1 ddp; trailing; 2 ddp; trailing; 3 ddp; trailing; 4 ddp; trailing; 5
ddp; 6 offset; 7 ddp; trailing; 8 ddp; 9 offset; 10 ddp; trailing; 11 ddp; trailing; 12
ddp; trailing; 13 ddp; trailing; 14 ddp; 15 ddp; trailing; 16 ddpARAP SMAR
@TBUF TTY 2: ring end 936C62, start 934ED4, need 58 bytes
ARAP SMARTBUF TTY 2: new seq 161

ARAP TTY 4: Received TICKLE
ARAP TTY 4: ----- ACKing 125 -----
ARAP TTY 2: Received TICKLE
ARAP TTY 2: ----- ACKing 114 -----

V42bis TTY 4: OUT uncomp (12): 0 10 16 33 0 9 1 195 255 255 255 255
V42bis TTY 4: OUT comp (6): 10 38 229 203 3 0
V42bis TTY 4: IN comp (6): 205 145 196 79 2 0
V42bis TTY 4: IN uncomp (12): 0 10 16 143 0 9 0 0 255 255 255 255
V42bis TTY 4: OUT uncomp (6): 0 4 16 143 0 0
V42bis TTY 4: OUT comp (6): 182 244 235 0 2 0
V42bis TTY 4: IN comp (6): 217 111 250 0 2 0
V42bis TTY 4: IN uncomp (6): 0 4 16 33 0 0
V42bis TTY 2: IN comp (5): 247 225 15 102 0
V42bis TTY 2: IN uncomp (12): 0 10 16 132 0 9 255 219 255 255 255 255
```

```
V42bis TTY 2: OUT uncomp (6): 0 4 16 132 0 0
V42bis TTY 2: OUT comp (6): 126 63 196 65 2 0
.....
.....
```

The boldfaced portion of this example shows that for line 2, **LA** is the MNP4 acknowledge frame, **31** is the sequence number of the last frame, and **08** is the window size.

ARA Configuration and Connection Examples

This section contains the following examples of and procedures for ARA configuration:

- ARA Server Configuration Procedure
- Dedicated ARA Line with User Authentication
- Autostart Multiple ARA Lines with User Authentication
- Telebit T-3000 Modem Setup Procedure
- Modified and Unmodified CCL Scripts
- ARA Router Support
- Extended AppleTalk Network
- Cable Range Expansion
- Extended Network in Discovery Mode
- TACACS Username Authentication
- TACACS Enabled for ARA Authentication
- AppleTalk Network Connection over a Foreign Protocol

ARA Server Configuration Procedure

The following sample procedure shows how to set up ARA functionality.

Log in to the router, use the **enable** command to enter your password if one is set, use the **configure** command to enter configuration mode, and add the following commands to your configuration:

```
appletalk routing
arap network 104 ARAP Dialin Zone
interface ethernet 0
  appletalk cable-range 0-0 0.0
! Puts router in discovery mode.
line 5 6
  modem inout
  speed 38400
  arap enabled
  autoselect
```

If you already know the cable range and the zone names you need, include the information in the configuration file. If you do not know this information, perform the following steps to use the discovery mode to allow the Cisco IOS software to learn about the AppleTalk network:

-
- Step 1** Permit the Cisco IOS software to monitor the line for a few minutes.
- Step 2** Log in and enter configuration mode.

- Step 3** Show the configuration again (using the **more nvram:startup-config** command).
- Step 4** Note the **appletalk cable-range** and **appletalk zone** variables.
- Step 5** Manually add the information in those two entries and add any user accounts:
- ```
appletalk cable-range 105-105 105.222
appletalk zone Marketing Lab
username arouser password arapasswd
! Add as many users as you need.
```
- Step 6** Save the configuration.
- Step 7** Show the configuration again (using the **more nvram:startup-config** command) to make sure the configuration is correct.
- 

## Dedicated ARA Line with User Authentication

The following example configures line 2 as a dedicated ARA line with user authentication information on the ARA server; guests are not allowed to make ARA sessions:

```
username jsmith password woof
line 2
 arap dedicated
 arap noguest
```

## Autostart Multiple ARA Lines with User Authentication

The following example enables ARA on lines 2 through 16 username authentication is configured on the ARA server, and the lines are configured to automatically start an ARA session when an ARA user on a Macintosh attempts a connection.

```
username jsmith password woof
line 2 16
 autoselect
 arap enabled
 arap noguest
```

## Telebit T-3000 Modem Setup Procedure

The following procedure sets up a Telebit T-3000 modem that attaches to a router, which supports hardware flow control. The Macintosh will use a CCL script to configure the attached modem.



### Note

When you configure modems for ARA, turn off MNP4 error correction because it can cause connection failures for ARA 1.0 clients. For dedicated ARA lines, it is sufficient to turn off error correction completely in the modem; for multiuse lines it is preferable to leave all forms of non-MNP4 error correction enabled so that users of other protocols can achieve error-corrected connections. This restriction does not apply to installations that only receive calls from ARAP 2.0 clients.

---

- 
- Step 1** Start with the modem at factory defaults. (The preferred configuration for hardware flow control is AT&F9.) Use the **direct** command if you have a terminal attached to the modem, or use the T/D Reset sequence described in the Telebit T-3000 manual to reset the modem to the &F9 defaults.
- Step 2** Attach a hardware flow control-capable cable between the modem and the device with which you are configuring the modem. (At this point, the modem is in hardware flow control mode, with autobaud-rate-recognition, and can detect your speed from 300 to 38,400 bps at 8-N-1. However, the modem must receive the flow control signals from the device to which you have the modem attached.)
- Step 3** Send the modem the following AT commands:

```
ATS51=6 E0 Q1 S0=2 &D3 &R3 S58=2 &W
```

This sequence directs the modem to perform the following tasks:

- Lock your DTE interface speed to 38,400 bps.
  - Turn “command echo” off.
  - Do not send any result codes.
  - Auto-answer on the second ring (Germany requires this setting, but elsewhere you can set it to answer on the first ring with “s0=1”).
  - When data terminal ready (DTR) is toggled, reset to the settings in NVRAM.
  - CTS is always enabled if hardware flow control is disabled.
  - Use full-duplex request to send/clear to send (RTS/CTS) flow control.
  - Write these settings to NVRAM.
- Step 4** At this point, if you press the Return key or enter characters, no characters appear on your screen because the result codes are turned off. You can determine whether the modem is working by getting a list of its configuration registers using the following AT command:

```
AT&V
```

- Step 5** After the modem is configured, connect it to the router with a modem-to-RJ-45 adapter and an RJ-45 cable to the lines(s) that you plan to use.

The following Cisco IOS commands are compatible with the Telebit 3000 settings described in this section:

```
line 1 8
 arap enable
 autoselect
 no escape-character
 flowcontrol hardware
 modem dialin
 speed 38400
```

---

## Modified and Unmodified CCL Scripts

If you are currently using modified CCL scripts and want to migrate to nonmodified scripts, you can set your system to accept logins using both modified CCL and unmodified scripts. Use the following commands in line configuration mode:

```
autoselect arap
autoselect during-login
arap noquest if-needed
```

## ARA Router Support

The following example configures the router for ARA support, as described in the comments (lines beginning with an exclamation point [!]).

```
! Enable AppleTalk on the router
appletalk routing
!
interface Ethernet 0
 ip address 172.30.1.1 255.255.255.0
!
! On interface Ethernet 0, assign network number 103 to the physical cable and
! assign zone name "Marketing Lab" to the interface. Assign a zone name if
! you are creating a new AppleTalk internet. If the internet already exists,
! the zone and cable range must match exactly, or you can leave the cable
! range at 0 to enter discovery mode. The suggested AppleTalk address for the interface in
! this example is 103.1
interface Ethernet 0
 appletalk cable-range 103-103 103.1
 appletalk zone Marketing Lab
! Configure a username and password for the router.
username jake password sesame
! On lines 4 through 8, InOut modems are specified, the lines are configured
! to automatically start an EXEC session or enable AppleTalk, AppleTalk Remote
! Access Protocol is enabled, the modem speed is specified as 38400 bps, and
! hardware flow control is enabled.
line 4 8
 modem InOut
 autoselect
 arap enabled
 speed 38400
 flowcontrol hardware
```



### Note

---

You must set your terminal emulator to match the speed that you set for the line.

---

## Extended AppleTalk Network

The following example configures the interface for an extended AppleTalk network. It defines the zones Orange and Brown. The cable range of one allows compatibility with nonextended AppleTalk networks.

```
appletalk routing
interface ethernet 0
 appletalk cable-range 1-1
 appletalk zone Orange
 appletalk zone Brown
```

## Cable Range Expansion

The following example changes the cable range and reenters the zone name. The initial configuration is as follows:

```
appletalk cable-range 100-103
appletalk zone Twilight Zone
```

The cable range is expanded as follows:

```
appletalk cable-range 100-109
```

At this point, you must reenter the zone name as follows:

```
appletalk zone Twilight Zone
```

## Extended Network in Discovery Mode

The following example configures an extended network in discovery mode. In Figure 111, access Server A provides the zone and network number information to the interface when it starts.

**Figure 111** *Discovery Mode*

The following example configures an extended network in discovery mode:

```
appletalk routing
interface ethernet 0
 appletalk cable-range 0-0 0.0
```

## TACACS Username Authentication

The following example for TACACS and Extended TACACS configures line 1 for ARA and username authentication on a TACACS server:

```
line 1
 login tacacs
 arap enable
```

The following example configures AAA/TACACS+ on line 1 for ARA and username authentication on a TACACS server:

```
line 1
 login authentication
 arap authentication
```

## TACACS Enabled for ARA Authentication

The following example shows regular TACACS enabled for ARA authentication:

```
line 3
 arap use-tacacs
```

The following example shows AAA/TACACS+ enabled for ARA authentication:

```
line 3
 aaa authentication arap
```

## AppleTalk Network Connection over a Foreign Protocol

The following example enables a Macintosh client running ARA on a remote network to connect across an X.25 network, through the router, to an AppleTalk network. In this example, virtual terminal lines 0 through 19 are configured for ARA:

```
appletalk routing
line vty 0 19
 arap enable
 autocommand arap
 arap dedicated
 arap timelimit 45
 arap warningtime 5
 arap noguest
 arap require-manual-password
 arap net-access-list 611
```

The Macintosh client connects to any virtual terminal line from 0 through 19. When the EXEC prompt appears, ARA begins automatically on the line (because of the **autocommand arap** command). The virtual terminal lines 0 through 19 are dedicated to ARA dial-in clients, and those clients have a 45-minute time limit. Five minutes before the line is disconnected, a warning message appears, indicating that the session will be disconnected in five minutes. Guest access is denied, and manual password entry is required. The AppleTalk access list 611 has been applied to the virtual terminal lines, meaning that access to other networks through these virtual terminal lines has been limited.