



# Configuring Token Ring LAN Emulation for Multiprotocol over ATM

---

This chapter describes the required and optional tasks for configuring the Multiprotocol over ATM (MPOA) for Token Ring Networks feature. For a complete description of the MPOA Client commands used in this chapter, refer to the “MPOA Commands” chapter in the *Cisco IOS Switching Services Command Reference*. For documentation of other commands that appear in this chapter, you can use the command reference master index or search online.

The MPOA for Token Ring Networks feature allows Token Ring hosts on an ATM network to communicate over direct paths (called shortcuts) through the ATM network. These shortcuts bypass the intermediate router hops that otherwise would be encountered in the default path.

## How Token Ring MPOA Works

Token Ring MPOA is an extension to LAN Emulation (LANE). It allows Token Ring LANE clients to forward IP packets between subnets to other Token Ring LANE clients through a shortcut in the ATM network. The Token Ring LANE clients have an MPOA client (MPC) communicating with an MPOA server (MPS) to establish this shortcut.

## Token Ring LANE for MPOA Configuration Task List

To configure Token Ring LANE for MPOA, complete the following tasks:

- Configuring a Token Ring LEC
- Configuring the LECS Database
- Configuring the LES/BUS

## Configuring a Token Ring LEC

For MPOA operation, a LEC must be associated with an MPS, an MPC, or both. Once a LEC is bound to a particular MPS/MPC, it cannot be bound to another MPS/MPC at the same time.

The LEC must also be associated with a physical interface or subinterface, which may be different from the physical interface associated with the MPS or MPC. For proper operation, all interfaces must belong to the same ATM network.

To configure a Token Ring LEC, use the following commands in global configuration mode:

	Command	Purpose
Step 1	<code>interface atm</code> { <i>slot/port.subinterface-number</i>   <i>number.subinterface-number</i> }	Specifies the ATM interface to be associated with the LEC.
Step 2	<code>lane client tokenring</code> [ <i>elan-name</i> ]	Defines a Token Ring LEC on a specified ELAN name.
Step 3	<code>lane client mpoa server</code> <i>mps-name</i>	(Optional) Binds a Token Ring LEC to an MPS.
Step 4	<code>lane client mpoa client</code> <i>mpc-name</i>	(Optional) Binds a Token Ring LEC to an MPC.

## Configuring the LECS Database

To configure the LECS database, use the following commands in global configuration mode:

	Command	Purpose
Step 1	<code>lane database</code> <i>database-name</i>	Creates a named database for the LECS.
Step 2	<code>name</code> <i>elan-name</i> <code>server-atm-address</code> <i>atm-address</i>	Binds the name of the ELAN to the ATM address of the LES.
Step 3	<code>name</code> <i>elan-name</i> <code>elan-id</code> <i>id</i>	Defines the ELAN ID in the LECS database to participate in MPOA.
Step 4	<code>name</code> <i>elan-name</i> <code>local-seg-id</code> <i>id</i>	Configures the local segment ID number.

## Configuring the LES/BUS

To configure the LES/BUS, use the following commands in global configuration mode:

	Command	Purpose
Step 1	<code>interface atm</code> { <i>slot/port.subinterface-number</i>   <i>number.subinterface-number</i> }	Specifies the ATM subinterface to be associated with the LES/BUS.
Step 2	<code>lane server-bus tokenring</code> <i>elan-name</i> [ <i>elan-id elan-id</i> ]	Defines a Token Ring LES/BUS on the named ELAN. The ELAN ID is optional.

## Token Ring LANE Configuration Examples

This section provides the following sample configurations of MPOA in a Token Ring LANE environment:

- MPOA Token Ring LANE Configuration in an IP-Routed Domain Example
- MPOA Token Ring LANE Configuration in an IP SRB-Routed Domain Example

## MPOA Token Ring LANE Configuration in an IP-Routed Domain Example

Figure 60 illustrates MPOA in a Token Ring LANE environment where MPC-to-MPC shortcuts are established between Token Ring LANE edge routers that reside in different IP-routed domains.

Figure 60 Token Ring MPOA—MPC to MPC Shortcut in an IP Routed Environment

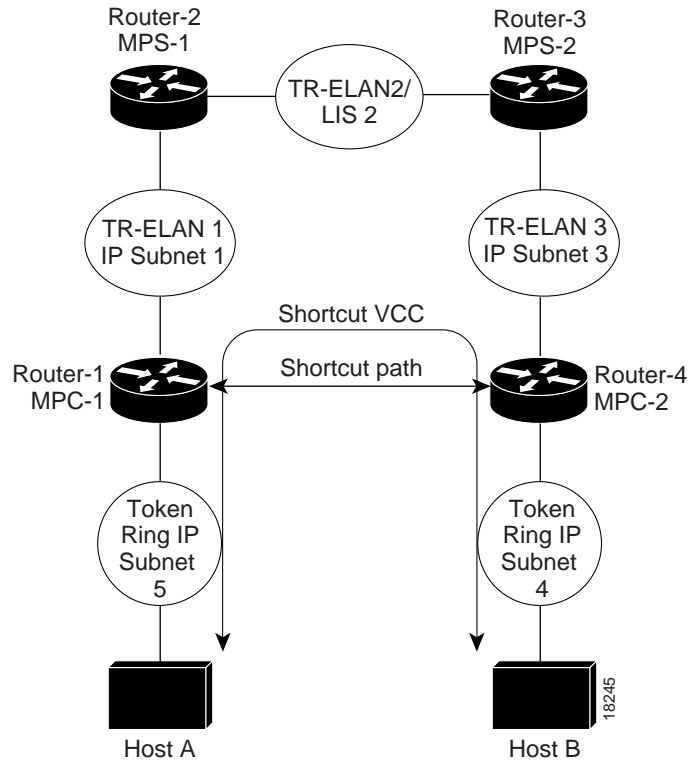

The following commands show a sample configuration for Router-1 in Figure 60:

```
hostname Router-1
!
ip routing
!
! Define the MPOA Client (mpc-1) configuration.
!
mpoa client config name mpc-1
!
! Configure an IP address on the Token Ring interface.
!
interface TokenRing1/0
 ip address 5.5.5.2 255.255.255.0
 ring-speed 16
!
! Configure a config-server and bind it to its database (mpoa-db).
! Attach the MPOA client mpc-1 to its ATM interface.
!
interface ATM2/0
 no ip address
 atm pvc 1 0 5 qsaal
 atm pvc 2 0 16 ilmi
 lane config auto-config-atm-address
 lane config database mpoa-db
 mpoa client name mpc-1
!
! Configure a LANE server-bus and LANE client on ELAN 1. Bind the
! LANE client to its MPOA Client (mpc-1).
!
interface ATM2/0.1 multipoint
 ip address 1.1.1.1 255.255.255.0
 lane server-bus tokenring 1
 lane client mpoa client name mpc-1
 lane client tokenring 1
!
router eigrp 1
 network 1.0.0.0
 network 5.0.0.0
!
end
```

The following commands show a sample configuration for Router-2 in Figure 60:

```
hostname Router-2
!
ip routing
!
! Configure the config-server database mpoa-db with configuration
! for ELANs 1 to 3
!
lane database mpoa-db
name 1 server-atm-address 47.0091810000000060705BFA01.00000CA05F41.01
name 1 local-seg-id 1000
name 1 elan-id 100
name 2 server-atm-address 47.0091810000000060705BFA01.00000CA05B41.01
name 2 local-seg-id 2000
name 2 elan-id 200
name 3 server-atm-address 47.0091810000000060705BFA01.00000CA05B41.03
name 3 local-seg-id 3000
name 3 elan-id 300
!
! Define the MPOA Server (mps-1) configuration.
mpoa server config name mps-1
!
! Configure the signalling and ILMI PVCs. Also configure a config-server
! and attach the MPOA server (mps-1) to its ATM interface.
!
interface ATM4/0
no ip address
atm pvc 1 0 5 qsaal
atm pvc 2 0 16 ilmi
lane config auto-config-atm-address
lane config database mpoa-db
mpoa server name mps-1
!
! Configure a Token Ring LANE client on ELAN 1 and bind the LANE
! client to its MPOA server (mps-1).
!
interface ATM4/0.1 multipoint
ip address 1.1.1.2 255.255.255.0
lane client mpoa server name mps-1
lane client tokenring 1
!
! Configure a Token Ring LANE client on ELAN 2 and bind the LANE
! client to its MPOA server (mps-1)
!
interface ATM4/0.2 multipoint
ip address 2.2.2.1 255.255.255.0
lane client mpoa server name mps-1
lane client tokenring 2
!
router eigrp 1
network 1.0.0.0
network 2.0.0.0
!
end
```

The following commands show a sample configuration for Router-3 in Figure 60:

```
hostname Router-3
!
ip routing
!
! Defines the MPOA Server (mps-2) configuration.
mpoa server config name mps-2
!
! Configure the signalling and ILMI PVCs and attach the MPOA
! server (mps-2) to its ATM interface.
!
interface ATM2/0
  no ip address
  atm pvc 1 0 5 qsaal
  atm pvc 2 0 16 ilmi
  mpoa server name mps-2
!
! Configure a Token Ring LANE client and LANE server-bus on ELAN 2
! and bind the LANE client to its MPOA server (mps-2)
!
interface ATM2/0.1 multipoint
  ip address 2.2.2.2 255.255.255.0
  lane server-bus tokenring 2
  lane client mpoa server name mps-2
  lane client tokenring 2
!
! Configure a Token Ring LANE client on ELAN 3 and bind the LANE
! client to its MPOA server (mps-2)
!
interface ATM2/0.3 multipoint
  ip address 3.3.3.1 255.255.255.0
  lane server-bus tokenring 3
  lane client mpoa server name mps-2
  lane client tokenring 3
!
router eigrp 1
  network 2.0.0.0
  network 3.0.0.0
!
end
```

The following commands show a sample configuration for Router-4 in Figure 60:

```
hostname Router-4
!
ip routing
!
! Define the MPOA client (mpc-2) configuration.
!
mpoa client config name mpc-2
!
! Configure the Token Ring interface
!
interface TokenRing1/0
 ip address 4.4.4.1 255.255.255.0
 ring-speed 16
!
! Configure the signalling and ILMI PVCs and attach the MPOA
! client to its ATM interface.
!
interface ATM2/0
 atm pvc 1 0 5 qsaal
 atm pvc 2 0 16 ilmi
 mpoa client name mpc-2
!
! Configure a Token Ring LANE client on ELAN 3 and bind the LANE
! client to its MPOA client (mpc-2).
!
interface ATM2/0.1 multipoint
 ip address 3.3.3.2 255.255.255.0
 lane client mpoa client name mpc-2
 lane client tokenring 3
!
router eigrp 1
 network 3.0.0.0
 network 4.0.0.0
!
end
```

## MPOA Token Ring LANE Configuration in an IP SRB-Routed Domain Example

Figure 61 illustrates MPOA in a Token Ring LANE environment where MPC-to-MPC shortcuts are established between a Token Ring LANE edge device and a Token Ring LANE router that reside in an IP SRB domain and IP-routed domains.

Figure 61 Token Ring MPOA—MPC to MPC Shortcut in an IP SRB-Routed Environment

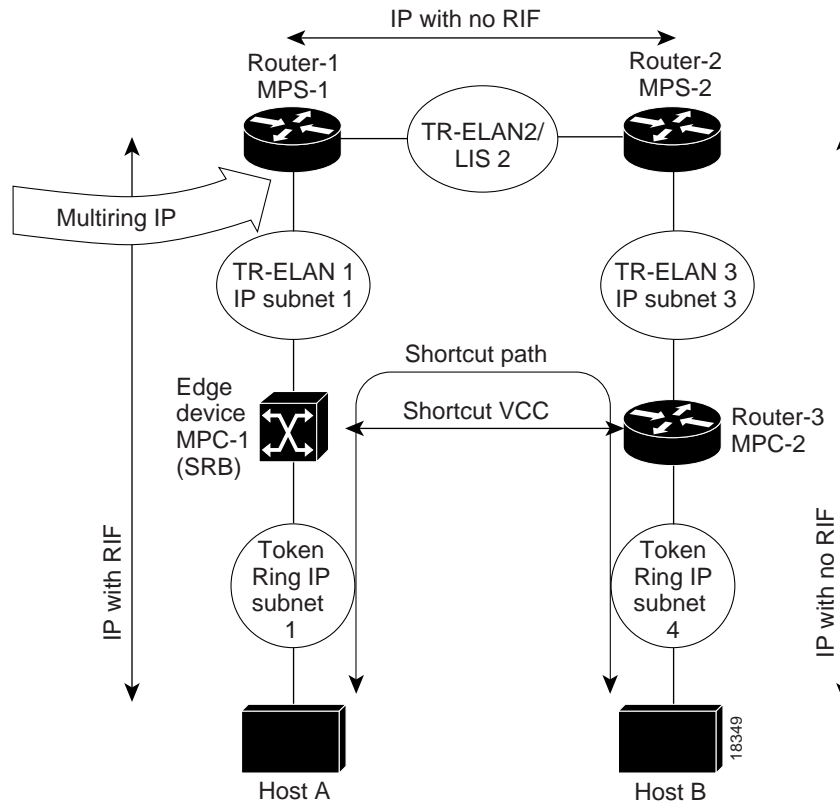

**Note** MPC support for the Cisco Catalyst 5000 ATM modules is planned for a future release.

The following commands show a sample configuration for Router-1 in Figure 61:

```
hostname Router-1
!
ip routing
!
! Configure the config-server database mpoa-db with configuration
! for ELANs 1 to 3
lane database mpoa-db
  name 1 server-atm-address 47.0091810000000060705BFA01.00000CA05F41.01
  name 1 local-seg-id 1000
  name 1 elan-id 100
  name 2 server-atm-address 47.0091810000000060705BFA01.00000CA05B41.01
  name 2 local-seg-id 2000
  name 2 elan-id 200
  name 3 server-atm-address 47.0091810000000060705BFA01.00000CA05B41.03
  name 3 local-seg-id 3000
  name 3 elan-id 300
!
! Define the MPOA Server (mps-1) configuration.
mpoa server config name mps-1
!
! Configure the signalling and ILMI PVCs. Also configure a config-server
! and attach the MPOA server (mps-1) to its ATM interface.
interface ATM4/0
  no ip address
  atm pvc 1 0 5 qsaal
  atm pvc 2 0 16 ilmi
  lane config auto-config-atm-address
  lane config database mpoa-db
  mpoa server name mps-1
!
! Configure a Token Ring LANE client on ELAN 1 and bind the LANE
! client to its MPOA server (mps-1). The multiring ip configuration
! is required to terminate the RIF for IP packets on the ELAN.
interface ATM4/0.1 multipoint
  ip address 1.1.1.2 255.255.255.0
  lane client mpoa server name mps-1
  lane client tokenring 1
  multiring ip
!
! Configure a Token Ring LANE client on ELAN 2 and bind the LANE
! client to its MPOA server (mps-1)
!
interface ATM4/0.2 multipoint
  ip address 2.2.2.1 255.255.255.0
  lane client mpoa server name mps-1
  lane client tokenring 2
!
!
router eigrp 1
  network 1.0.0.0
  network 2.0.0.0
!
end
```

The following commands show a sample configuration for Router-2 in Figure 61:

```
hostname Router-2
!
ip routing
!
! Defines the MPOA Server (mps-2) configuration.
mpoa server config name mps-2
!
!
! Configure the signalling and ILMI PVCs and attach the MPOA
! server (mps-2) to its ATM interface.
interface ATM2/0
  no ip address
  atm pvc 1 0 5 qsaal
  atm pvc 2 0 16 ilmi
  mpoa server name mps-2
!
! Configure a Token Ring LANE client and LANE server-bus on ELAN 2
! and bind the LANE client to its MPOA server (mps-2)
!
interface ATM2/0.1 multipoint
  ip address 2.2.2.2 255.255.255.0
  lane server-bus tokenring 2
  lane client mpoa server name mps-2
  lane client tokenring 2
!
! Configure a Token Ring LANE client on ELAN 3 and bind the LANE
! client to its MPOA server (mps-2)
!
interface ATM2/0.3 multipoint
  ip address 3.3.3.1 255.255.255.0
  lane server-bus tokenring 3
  lane client mpoa server name mps-2
  lane client tokenring 3
!
router eigrp 1
  network 2.0.0.0
  network 3.0.0.0
!
end
```

The following commands show a sample configuration for Router-3 in Figure 61:

```
hostname Router-3
!
ip routing
!
! Define the MPOA client (mpc-2) configuration.
mpoa client config name mpc-2
!
!
! Configure the Token Ring interface
interface TokenRing1/0
 ip address 4.4.4.1 255.255.255.0
 ring-speed 16
!
! Configure the signalling and ILMI PVCs and attach the MPOA
! client to its ATM interface.
!
interface ATM2/0
 atm pvc 1 0 5 qsaal
 atm pvc 2 0 16 ilmi
 mpoa client name mpc-2
!
! Configure a Token Ring LANE client on ELAN 3 and bind the LANE
! client to its MPOA client (mpc-2).
!
interface ATM2/0.1 multipoint
 ip address 3.3.3.2 255.255.255.0
 lane client mpoa client name mpc-2
 lane client tokenring 3
!
router eigrp 1
 network 3.0.0.0
 network 4.0.0.0
!
end
```

