



Configuring the Multiprotocol over ATM Client

This chapter describes the required and optional tasks for configuring the Multiprotocol over ATM (MPOA) Client. For a complete description of the MPOA Client commands used in this chapter, refer to the “MPOA Commands” chapter in the *Cisco IOS Switching Services Command Reference*. For documentation of other commands that appear in this chapter, you can use the command reference master index or search online.

The MPOA Client functionality involves ingress/egress cache management, data-plane and control-plane virtual circuit connection (VCC) management, MPOA frame processing, and participation in MPOA protocol and MPOA flow detection.

How MPC Works

The MPC software module implements the functionality of the MPC in compliance with the ATM Forum MPOA specification. An MPOA Client (MPC) identifies packets sent to an MPOA-capable router over the nonbroadcast multi-access (NBMA) network and establishes a shortcut VCC to the egress MPC, if possible. The MPC then routes these packets directly over this shortcut VCC, bypassing the intermediate routers and enabling the fast routing of internetwork-layer packets across an NBMA network.

The Catalyst 5000 series switch can be designated as an MPC. If the Catalyst 5000 series switch is configured with an RSM/VIP2 (with an ATM interface) it can be configured as an MPC or an MPS.

A router is usually designated as an MPOA Server (MPS), but can also be designated as an MPC. MPC on the router is primarily meant to provide router-initiated and router-terminated shortcuts for non-NBMA networks. For this reason, MPC information in this publication primarily refers to the Catalyst 5000 series switch, and MPS information refers to the router or the RSM/VIP2 with an ATM interface in a Catalyst 5000 series switch.

MPC Configuration Task List

To configure an MPC on your network, perform the following tasks:

- Configuring the ELAN ID (Required)
- Configuring the MPC (Required)
- Configuring the MPC Variables (Optional)
- Monitoring and Maintaining the MPC (Optional)

Configuring the ELAN ID

For MPOA to work properly, a LEC must belong to an ELAN that has a defined ELAN ID. To obtain an ELAN ID, use either of the following commands:



Note

To configure an MPC on a Catalyst 5000 series ATM module, establish connection with the ATM module, enter privileged mode, and then enter configuration mode. For information on performing these tasks, refer to the *Catalyst 5000 Series Software Configuration Guide*.

Command	Purpose
<code>name elan-name elan-id id</code>	Defines an ELAN ID for the LEC (in LANE database configuration mode).
<code>lane server-bus ethernet elan-name [elan-id id]</code>	Configures the LEC with the ELAN ID (in interface configuration mode).



Caution

If an ELAN ID is supplied, make sure both commands use the same elan-id value.

Configuring the MPC

To configure an MPC on your network, use the following commands in the appropriate configuration modes:

	Command	Purpose
Step 1	<code>mpoa client config name mpc-name</code>	In global configuration mode, defines an MPC with a specified name.
Step 2	<code>interface atm {mod-num/port-num number}</code>	In interface configuration mode, specifies the ATM interface to which the MPC is associated.
Step 3	<code>mpoa client name mpc-name</code>	In interface configuration mode, attaches an MPC to the ATM interface.
Step 4	<code>interface atm-num.sub-interface-num</code>	In interface configuration mode, specifies the ATM interface that contains the LEC to which you will bind the MPC.
Step 5	<code>lane client mpoa client name mpc-name</code>	In interface configuration mode, binds a LANE client to the specified MPC.
	Repeat Steps 4 and 5 for every LEC to be served by the MPC/MPS.	



Note

In Step 4, if you do not specify the **mul** keyword when entering a subinterface number, the CLI does not accept the command.

Configuring the MPC Variables

An MPC has to be defined with a specified name before you can change its variables.

To change the variables for an MPC, use the following commands, beginning in MPC configuration mode:

	Command	Purpose
Step 1	<code>mpoa client config name <i>mps-name</i></code>	Defines an MPC with the specified name.
Step 2	<code>atm-address <i>atm-address</i></code>	(Optional) Specifies the control ATM address that the MPC should use (when it is associated with a hardware interface).
Step 3	<code>shortcut-frame-count <i>count</i></code>	(Optional) Specifies the maximum number of times a packet can be routed to the default router within shortcut-frame time before an MPOA resolution request is sent.
Step 4	<code>shortcut-frame-time <i>time</i></code>	(Optional) Sets the shortcut-setup frame time for the MPC.

Monitoring and Maintaining the MPC

To monitor and maintain the configuration of an MPC, use any of these commands in EXEC mode:

Command	Purpose
<code>show mpoa client [<i>name mpc-name</i>]</code>	Displays information about a specified MPC or all MPCs.
<code>show mpoa client [<i>name mpc-name</i>] cache [<i>ingress</i> <i>egress</i>] [<i>ip-addr ip-addr</i>]</code>	Displays ingress and egress cache entries associated with an MPC.
<code>show mpoa client [<i>name mpc-name</i>] statistics</code>	Displays all the statistics collected by an MPC.
<code>clear mpoa client [<i>name mpc-name</i>] cache [<i>ingress</i> <i>egress</i>] [<i>ip-addr ip-addr</i>]</code>	Clears cache entries.
<code>show mpoa client [<i>name mpc-name</i>] [<i>remote-device</i>]</code>	Displays all the MPOA devices that this MPC has learned.
<code>show mpoa default-atm-addresses</code>	Displays the default ATM addresses for the MPC.

MPC Configuration Example

This section contains an example of the commands needed to configure an MPC. The lines beginning with exclamation points (!) are comments explaining the command shown on the subsequent line. Figure 58 shows an example of how you can configure your system to use MPOA.

Figure 58 Example of an MPOA Configuration

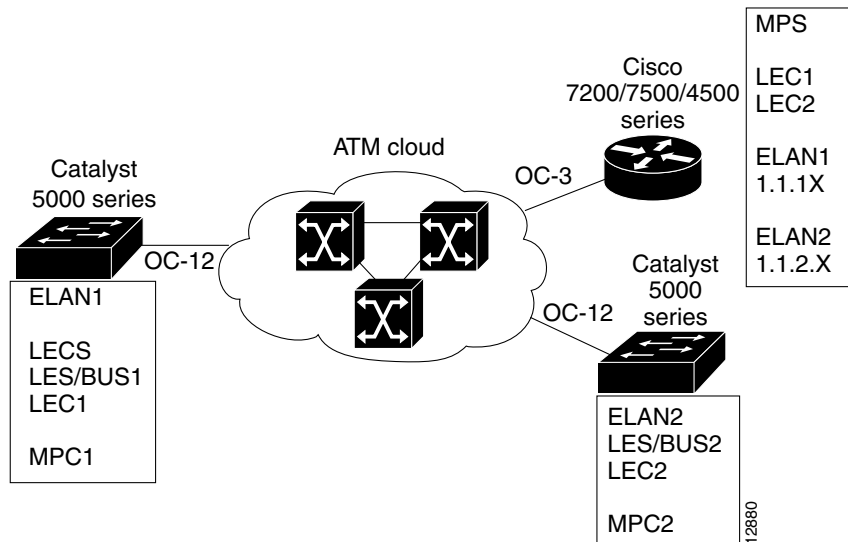

The following example configures the MPC and attaches the MPC to a hardware interface.

```
! Define the MPC "MYMPC"
mpoa client config name MYMPC
! Leave everything as default
exit
! Specify the ATM interface to which the MPC is attached
interface ATM 1/0
! Attach MPC MYMPC to the HW interface
mpoa client name MYMPC
! Specify the ATM interface that contains the LEC to which you will bind the MPC
interface atm 1/0.1
! Bind a LANE client to the specified MPC
lane client mpoa client name MYMPC
! Go back up to global config mode
exit
```

The following example shows a typical configuration file for the first MPC:

```
Current configuration:
!
version 11.3
! Go to LANE database config mode
  exit
lane database mpoa-test
hostname mpc-1
! Define the ELAN ID and ATM address
name elan1 server-atm-address 47.00918100000000613E5A2F01.006070174821.01
name elan1 elan-id 101
name elan2 server-atm-address 47.00918100000000613E5A2F01.006070174821.02
name elan2 elan-id 102
! Define the MPC "mpc-1"
mpoa client config name mpc-1
  interface Ethernet0
! Go back up to global config mode
  exit
! Specify the ATM interface to which the MPC is attached
interface ATM0
  atm pvc 1 0 5 qsaal
  atm pvc 2 0 16 ilmi
  lane config auto-config-atm-address
  lane config database mpoa-test
! Attach MPC mpc-1 to the HW interface
  mpoa client name mpc-1
! Specify the ATM interface that contains the LEC to which you will bind the MPC
interface ATM0.1 multipoint
  lane server-bus ethernet elan1
! Bind a LANE client to the specified MPC
  lane client mpoa client name mpc-1
  lane client ethernet 1 elan1
! Go back up to global config mode
  exit
```

The following example shows a typical configuration file for the second MPC:

```
Current configuration:
!
version 11.3
hostname mpc-2
! Go back up to global config mode
  exit
! Define the MPC "mpc-2"
mpoa client config name mpc-2
! Specify the ATM interface to which the MPC is attached
interface ATM0
  atm pvc 1 0 5 qsaal
  atm pvc 2 0 16 ilmi
  mpoa client name mpc-2
! Specify the ATM interface that contains the LEC to which you will bind the MPC
interface ATM0.1 multipoint
  lane server-bus ethernet elan2
  lane client mpoa client name mpc-2
  lane client ethernet 2 elan2
! Go back up to global config mode
  exit
```

