



Configuring LAN Interfaces

Use the information in this chapter to configure LAN interfaces supported on Cisco routers and access servers.

This chapter describes the processes for configuring LAN interfaces in the following sections:

- Configuring an Ethernet or Fast Ethernet Interface
- Configuring Fast EtherChannel
- Configuring a Fiber Distributed Data Interface
- Configuring a Hub Interface
- Configuring a LAN Extender Interface
- Configuring a Token Ring Interface

For examples of configuration tasks, see the “LAN Interface Configuration Examples” section.

For hardware technical descriptions and information about installing interfaces, refer to the hardware installation and configuration publication for your product. For a complete description of the LAN interface commands used in this chapter, refer to the “Interface Commands” chapter of the *Cisco IOS Interface Command Reference*. To locate documentation of other commands that appear in this chapter, use the command reference master index or search online.

Configuring an Ethernet or Fast Ethernet Interface

Cisco supports both 10-Mbps Ethernet and 100-Mbps Fast Ethernet.

Support for the 10-Mbps and 100-Mbps Ethernet interface is supplied on various Ethernet network interface cards or systems.

The Fast Ethernet NP-1FE module, for example, provides the following benefits:

- **VLAN routing**—Virtual LAN (VLAN) support enables network managers to group users logically rather than by physical location. The high performance of the underlying Cisco 4700, combined with the feature-rich NP-1FE, makes it an ideal combination for a low-density, higher-performance application such as inter-VLAN routing.
- **High-speed interconnections**—The Fast Ethernet interface enables network managers to implement Fast-Ethernet routing solutions for optimal cost and performance across a wide range of applications, including campus or enterprise backbones and data centers. It is also a low-cost way to provide Fast-Ethernet access to traditional low-speed WAN services.
- **Local area network aggregation**—The Cisco 4500 or the Cisco 4700 series routers can support as many as 12 Ethernet, 4 Token Ring, or 1 FDDI segment. ISDN interfaces are also supported.

With the Catalyst 3000 or Catalyst 5000 system, the Fast Ethernet processor can be used to aggregate up to twelve 10-Mbps LANs and give them high-speed access to such Layer 3 routing services as providing firewalls and maintaining access lists.

Cisco 7200 series routers support an I/O controller with an RJ-45 interface. You can configure the optional Fast Ethernet port for use at 100-Mbps full-duplex or half-duplex operation (half duplex is the default). The Fast Ethernet port is equipped with either a single MII receptacle or an MII receptacle and an RJ-45 receptacle. To support this new feature, the **media-type** interface command has been modified. The **media-type** interface command now supports two options:

- **100basex**—Specifies an RJ-45 100BASE-X physical connection.
- **mii**—Specifies a media-independent interface.

Second-generation Fast Ethernet Interface Processors (FEIP2-DSW-2TX and FEIP2-DSW-2FX) are available on Cisco 7500 series routers and on Cisco 7000 series routers with the 7000 Series Route Switch Processor (RSP7000) and 7000 Series Chassis Interface (RSP7000CI). The FEIP2-DSW is a dual-port, fixed-configuration interface processor that provides two 100-Mbps Fast Ethernet (FE) interfaces. Each interface on the FEIP2-DSW supports half-duplex only for a maximum aggregate bandwidth of 200 Mbps.

Refer to the *Cisco Product Catalog* for specific platform and hardware compatibility information.

Use the **show interfaces**, **show controllers mci**, and **show controllers cbus EXEC** commands to display the Ethernet port numbers. These commands provide a report for each interface supported by the router or access server.

Use the **show interface fastethernet** command to display interface statistics, and use the **show controller fastethernet** to display the information about the Fast Ethernet controller chip. The output shows statistics, including information about initialization block information, transmit ring, receive ring and errors.

For information on how to configure Fast EtherChannel, see the tasks listed in the “Configuring Fast EtherChannel” section.

Ethernet and Fast Ethernet Interface Configuration Task List

Perform the tasks in the following sections to configure features on an Ethernet or Fast Ethernet interface:

- Specifying an Ethernet or Fast Ethernet Interface (Required)
- Specifying an Ethernet Encapsulation Method (Optional)
- Specifying Full-Duplex Operation (Optional)
- Specifying the Media and Connector Type (Optional)
- Extending the 10BASE-T Capability (Optional)
- Configuring Fast Ethernet 100BASE-T (Optional)
- Configuring PA-12E/2FE Port Adapter (Optional)
- Configuring the 100VG-AnyLAN Port Adapter (Optional)

Specifying an Ethernet or Fast Ethernet Interface

To specify an Ethernet interface and enter interface configuration mode, use one of the following commands in global configuration mode:

Command	Purpose
<code>interface ethernet <i>number</i></code>	Begins interface configuration.
<code>interface ethernet <i>slot/port</i></code>	Begins interface configuration for the Cisco 7200 and Cisco 7500 series routers.
<code>interface ethernet <i>slot/port-adapter/port</i></code>	Begins interface configuration for Cisco 7500 series routers.
<code>interface fastethernet <i>number</i></code>	Begins interface configuration for the Cisco 4000 series with a Fast Ethernet NIM installed.
<code>interface fastethernet <i>slot/port</i></code>	Specifies a Fast Ethernet interface and enters interface configuration mode on the Cisco 7200 series routers.
<code>interface fastethernet <i>slot/port-adapter/port</i></code>	Specifies a Fast Ethernet interface and enters interface configuration mode on the Cisco 7500 series routers.

Use the **show interfaces fastethernet** command to display the Fast Ethernet slots and ports. The Fast Ethernet NIM and the FEIP default to half-duplex mode.

Specifying an Ethernet Encapsulation Method

Currently, there are three common Ethernet encapsulation methods:

- The standard ARPA Ethernet Version 2.0 encapsulation, which uses a 16-bit protocol type code (the default encapsulation method)
- SAP IEEE 802.3 encapsulation, in which the type code becomes the frame length for the IEEE 802.2 LLC encapsulation (destination and source Service Access Points, and a control byte)
- The SNAP method, as specified in RFC 1042, “Standard for the Transmission of IP Datagrams Over IEEE 802 Networks,” which allows Ethernet protocols to run on IEEE 802.2 media

The encapsulation method you use depends upon the routing protocol you are using, the type of Ethernet media connected to the router or access server, and the routing or bridging application you configure.

Establish Ethernet encapsulation of IP packets by using one of the following commands in interface configuration mode:

Command	Purpose
<code>encapsulation arpa</code>	Selects ARPA Ethernet encapsulation.
<code>encapsulation sap</code>	Selects SAP Ethernet encapsulation.
<code>encapsulation snap</code>	Selects SNAP Ethernet encapsulation.

For an example of selecting Ethernet encapsulation for IP, see the “Ethernet Encapsulation Enablement Example” section.

Specifying Full-Duplex Operation

The default is half-duplex mode on the FEIP2-DSW-2FX. To enable full-duplex mode on the FEIP2-DSW-2FX (for a maximum aggregate bandwidth of 200 Mbps), use either of the following commands in interface configuration mode:

Command	Purpose
<code>full-duplex</code>	Enables full-duplex on the Fast Ethernet interface of the FEIP2-DSW-2FX.
or <code>no half-duplex</code>	

For an example to enable full-duplex mode on Fast Ethernet, see the “Full Duplex Enablement Operation Example” section.



Caution

To prevent system problems, do not configure both FEIP2-DSW-2FX interfaces for full-duplex operation at the same time.



Note

The FEIP2-DSW-2TX supports half-duplex only and should not be configured for full-duplex.

Specifying the Media and Connector Type

You can specify that the Ethernet network interface module (NIM) on the Cisco 4000 series routers use either the default of an AUI and a 15-pin connector, or 10BASE-T and an RJ-45 connector. To do so, use one of the following commands in interface configuration mode:

Command	Purpose
<code>media-type aui</code>	Selects a 15-pin Ethernet connector.
<code>media-type 10baset</code>	Selects an RJ-45 Ethernet connector.

The default media connector type is an RJ-45 or SC (fiber-optic) connector. You can specify that the interface uses either an MII connector, or an RJ-45 or SC (fiber-optic) connector (this is the default). To do so, use one of the following commands in interface configuration mode:

Command	Purpose
<code>media-type mii</code>	Selects an MII Ethernet connector.
<code>media-type 100basex</code>	Selects an RJ-45 Ethernet connector for the FEIP2-DSW-2TX or an SC connector for the FEIP2-DSW-2FX.



Note

When using the I/O controller that is equipped with an MII receptacle and an RJ-45 receptacle, only one receptacle can be configured for use at a time.

Extending the 10BASE-T Capability

On a Cisco 4000 series or Cisco 4500 series routers, you can extend the twisted-pair 10BASE-T capability beyond the standard 100 meters by reducing the *squelch* (signal cutoff time). This feature applies only to the LANCE controller 10BASE-T interfaces. LANCE is the AMD controller chip for the Cisco 4000 and Cisco 4500 Ethernet interface.



Note Does not apply to the Fast Ethernet interface.

To reduce squelch, use the first command in the following table in interface configuration mode. You can later restore the squelch by using the second command.

Command	Purpose
<code>squelch reduced</code>	Reduces the squelch.
<code>squelch normal</code>	Returns squelch to normal.

Configuring Fast Ethernet 100BASE-T

You must configure the Fast Ethernet 100BASE-T interface on a Cisco AS5300 so that it can be recognized as a device on the Ethernet LAN. The Fast Ethernet interface supports 10- and 100-Mbps speeds with the 100BASE-T and 10BASE-T routers, hubs, and switches.

To configure the interface, use the following commands beginning in privileged EXEC mode:

	Command	Purpose
Step 1	<code>configure terminal</code>	Enters global configuration mode.
Step 2	<code>interface fastethernet number</code>	Enters Fast Ethernet interface configuration mode.
Step 3	<code>ip address address subnet-mask</code>	Assigns an IP address and subnet mask to the interface.
Step 4	<code>speed {10 100 auto}</code>	Assigns a speed to the interface. The default is 100 Mbps. ¹ For relationship between duplex and speed command options, see Table 3.
Step 5	<code>duplex {full half auto}</code>	Sets up the duplex configuration on the Fast Ethernet interface. The default is half duplex. ¹ For relationship between duplex and speed command options, see Table 3.

1. The **auto** option automatically negotiates the speed based on the speed and the peer router, hub, or switch media.

To use the auto-negotiation capability (that is, to detect speed and duplex modes automatically), you must set both **speed** and **duplex** to **auto**. Setting the **speed** to **auto** negotiates speed only, and setting **duplex** to **auto** negotiates duplex only. Table 3 describes the access server's performance for different combinations of the **duplex** and **speed** command options. The specified **duplex** command option plus the specified **speed** command option produces the resulting system action.

Table 3 Relationship Between Duplex and Speed Command Options

Duplex Command	Speed Command	Resulting System Actions
<code>duplex auto</code>	<code>speed auto</code>	Autonegotiates both speed and duplex modes.
<code>duplex auto</code>	<code>speed 100</code> or <code>speed 10</code>	Autonegotiates both speed and duplex modes.
<code>duplex half</code> or <code>duplex full</code>	<code>speed auto</code>	Autonegotiates both speed and duplex modes.
<code>duplex half</code>	<code>speed 10</code>	Forces 10 Mbps and half duplex.
<code>duplex full</code>	<code>speed 10</code>	Forces 10 Mbps and full duplex.
<code>duplex half</code>	<code>speed 100</code>	Forces 100 Mbps and half duplex.
<code>duplex full</code>	<code>speed 100</code>	Forces 100 Mbps and full duplex.

Configuring PA-12E/2FE Port Adapter

The PA-12E/2FE Ethernet switch port adapter provides Cisco 7200 series routers with up to twelve 10-Mbps and two 10/100-Mbps switched Ethernet (10BASE-T) and Fast Ethernet (100BASE-TX) interfaces for an aggregate bandwidth of 435 Mbps, full-duplex. The PA-12E/2FE port adapter supports the Ethernet, IEEE 802.3, and IEEE 802.3u specifications for 10-Mbps and 100-Mbps transmission over UTP cables.

The PA-12E/2FE port adapter offloads Layer 2 switching from the host CPU by using store-and-forward or cut-through switching technology between interfaces within the same virtual LAN (VLAN) on the PA-12E/2FE port adapter. The PA-12E/2FE port adapter supports up to four VLANs (bridge groups).



Note

The PA-12E/2FE port adapter is a dual-width port adapter, which means it occupies two horizontally aligned port adapter slots when installed in a Cisco 7200 series router. (Single-width port adapters occupy individual port adapter slots in a Cisco 7200 series router.)

All interfaces on the PA-12E/2FE port adapter support autosensing and autonegotiation of the proper transmission mode (half-duplex or full-duplex) with an attached device. The first two PA-12E/2FE interfaces (port 0 and port 1) also support autosensing and autonegotiation of the proper connection speed (10-Mbps or 100-Mbps) with an attached device. If an attached device does not support autosensing and autonegotiation of the proper transmission mode, the PA-12E/2FE interfaces attached to the device automatically enter half-duplex mode. Use the **show system:running-config** command to determine if a PA-12E/2FE interface is autosensing and autonegotiating the proper transmission mode with an attached device. Use the **full-duplex** and the **half-duplex** commands to change the transmission mode of a PA-12E/2FE interface. After changing the transmission mode, use the **show interfaces** command to verify the interface's transmission mode.

**Note**

If you use the **full-duplex** and the **half-duplex** commands to change the transmission mode of the first two PA-12E/2FE interfaces (port 0 and port 1), the transmission speed of the two PA-12E/2FE interfaces automatically defaults to 100-Mbps. The first two PA-12E/2FE interfaces only operate at 10-Mbps when the interfaces are autosensing and autonegotiating the proper connection speed (10-Mbps or 100-Mbps) with an attached device.

To configure the PA-12E/2FE port adapter, perform the tasks in the following sections:

- Configuring the PA-12E/2FE Port Adapter (Required)
- Monitoring and Maintaining the PA-12E/2FE Port Adapter (Optional)
- Configuring Bridge Groups Using the 12E/2FE VLAN Configuration WebTool (Optional)

**Note**

If you plan to use a PA-12E/2FE interface to boot from a network (using TFTP), ensure that the interface is configured for a loop-free environment, an IP address is configured for the interface's bridge-group virtual interface, and system boot image 11.2(10)P is installed on your router (use the **show version** command to view your router's system boot image). Then, *before* booting from the network server, use the **bridge-group** *bridge-group number* **spanning-disabled** command to disable the Spanning-Tree Protocol configured on the interface to keep the TFTP server from timing out and closing the session.

For detailed information about booting from a network using TFTP, loading a system image from a network server, and configuring the Spanning-Tree Protocol on your Cisco 7200 series router, refer to the *PA-12E/2FE Ethernet Switch Port Adapter* book that accompanies the hardware and to the *Cisco IOS Bridging and IBM Networking Configuration Guide*.

For information on other commands that can be used to configure a PA-12E/2FE port adapter, refer to the “Interfaces Commands” chapter in the *Cisco IOS Interface Command Reference*. For information on bridging, refer to the “Configuring Transparent Bridging” chapter in the *Cisco IOS Bridging and IBM Networking Configuration Guide*.

For PA-12E/2FE port adapter configuration examples, see the “PA-12E/2FE Port Configuration Examples” section.

Configuring the PA-12E/2FE Port Adapter

This section provides instructions for a basic configuration. You might also need to enter other configuration commands depending on the requirements for your system configuration and the protocols you plan to route on the interface. For complete descriptions of configuration commands and the configuration options available, refer to the other configuration guides in the Cisco IOS documentation set.

To configure the interfaces on the PA-12E/2FE port adapter, use the following commands in global configuration mode:

	Command	Purpose
Step 1	<code>bridge bridge-group protocol ieee</code>	Specifies the type of Spanning-Tree Protocol. The PA-12E/2FE port adapter supports DEC and IEEE Spanning-Tree Protocols; however, we recommend using the IEEE protocol when configuring bridge groups.
Step 2	<code>interface fastethernet slot/port</code> (ports 0 and 1) <code>interface ethernet slot/port</code> (ports 2 through 13)	Enters the interface you want to configure.
Step 3	<code>bridge-group bridge-group</code>	Assigns a bridge group to the interface.
Step 4	<code>cut-through [receive transmit]</code>	(Optional) Configures the interface for cut-through switching technology. The default is store-and-forward (that is, no cut-through).
Step 5	<code>full-duplex</code>	(Optional) Configures the transmission mode for full-duplex, if an attached device does not support autosensing or autonegotiation. The default is half-duplex.
Step 6	<code>no shutdown</code>	Restarts the interface.
Step 7	<code>exit</code>	Returns to configuration mode.
Step 8		Repeat Steps 1 through 7 for each interface.
Step 9	<code>copy system:running-config nvram:startup-config</code>	Saves the new configuration to memory.

To enable integrated routing and bridging on the bridge groups, use the following commands beginning in global configuration mode:

	Command	Purpose
Step 1	<code>bridge irb</code>	Enables integrated routing and bridging.
Step 2	<code>interface bvi bridge-group</code>	Enables a virtual interface on a bridge group.
Step 3	<code>ip address address mask</code>	Assigns an IP address and subnet mask to the bridge-group virtual interface.
Step 4	<code>no shutdown</code>	Restarts the interface.
Step 5	<code>exit</code>	Returns to configuration mode.
Step 6		Repeat Steps 1 through 5 for each bridge group.
Step 7	<code>bridge bridge-group route protocol</code>	Specifies the protocol for each bridge group.
Step 8	<code>exit</code>	Exits configuration mode.
Step 9	<code>copy system:running-config nvram:startup-config</code>	Saves the new configuration to memory.

Monitoring and Maintaining the PA-12E/2FE Port Adapter

After configuring the new interface, you can display its status and verify other information. To display information about the PA-12E/2FE port adapter, use the following commands in EXEC mode:

Command	Purpose
<code>show version</code>	Displays the configuration of the system hardware, the software version, the names and sources of configuration files, and the boot image.
<code>show controllers</code>	Displays all current port adapters and their interfaces
<code>show interface fastethernet slot/port</code> (ports 0 and 1) or <code>show interface ethernet slot/port</code> (ports 2 through 13)	Displays the interfaces so you can verify that they have the correct slot number and that the interface and line protocol are in the correct state.
<code>show bridge group</code>	Displays all bridge groups and their interfaces.
<code>show interface ethernet slot/port irb</code> (ports 2 through 13) or <code>show interface fastethernet slot/port irb</code> (ports 0 and 1)	Displays the routed protocol so you can verify that it is configured correctly for each interface.
<code>show protocols</code>	Displays the protocols configured for the entire system and specific interfaces.
<code>show pas eswitch addresses fastethernet slot/port</code> (ports 0 and 1) or <code>show pas eswitch addresses ethernet slot/port</code> (ports 2 through 13)	Displays the Layer 2 learned addresses for each interface.
<code>more system:running-config</code>	Displays the running configuration file.
<code>more nvram:startup-config</code>	Displays the configuration stored in NVRAM.

Configuring Bridge Groups Using the 12E/2FE VLAN Configuration WebTool

The 12E/2FE VLAN Configuration WebTool, shown in Figure 2, is a web browser-based Java applet that displays configured interfaces and bridge groups for PA-12E/2FE port adapters installed in Cisco routers. With the WebTool you can perform the following tasks:

- Create and delete bridge groups (also referred to as VLANs)
- Add and remove PA-12E/2FE interfaces from bridge groups
- Assign colors to bridge groups and PA-12E/2FE interfaces
- Administratively shut down (disable) and bring up (enable) PA-12E/2FE interfaces
- View the bridge-group status of each PA-12E/2FE interface

You can access the 12E/2FE VLAN Configuration WebTool from your router's home page. For complete procedures on how to use the VLAN Configuration WebTool, refer to the *PA-12E/2FE Ethernet Switch Port Adapter* book that accompanies the hardware.

Figure 2 Example Home Page for a Cisco 7200 Series Router (Cisco 7206 Shown)

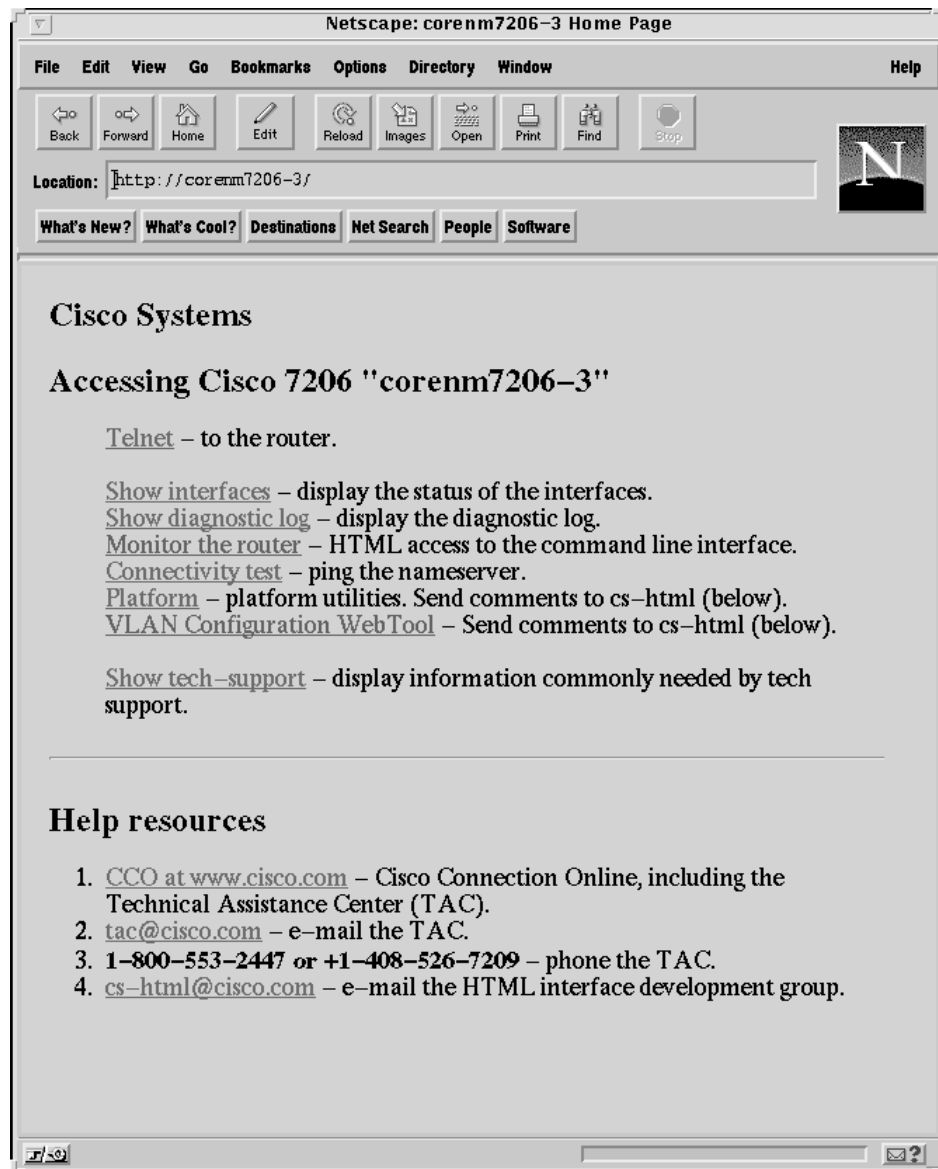

All Cisco routers running Cisco IOS Release 11.0 or later have a home page. All Cisco router home pages are password protected. Contact your network administrator if you do not have the name or password for your Cisco 7200 series router.

If your router has an installed PA- 12E/2FE port adapter, the 12E/2FE VLAN Configuration WebTool shown in Figure 2 can be accessed from the router's home page using a Java-enabled web browser.

Configuring the 100VG-AnyLAN Port Adapter

The 100VG-AnyLAN port adapter (PA-100VG) is available on Cisco 7200 series routers and on Cisco 7500 series routers.

The PA-100VG provides a single interface compatible with and specified by IEEE 802.12 to support 100 Mbps over Category 3 or Category 5 unshielded twisted-pair (UTP) cable with RJ-45 terminators. The PA-100VG supports 802.3 Ethernet packets and can be monitored with the IEEE 802.12 Interface MIB.

To configure the PA-100VG port adapter, use the following commands beginning in global configuration mode:

	Command	Purpose
Step 1	<code>interface vg-anylan</code> <i>slot/port-adapter/port</i> (Cisco 7500) or <code>interface vg-anylan slot/port</code> (Cisco 7200)	Specifies a 100VG-AnyLAN interface and enters interface configuration.
Step 2	<code>ip address ip-address mask</code>	Specifies the IP address and subnet mask to the interface.
Step 3	<code>frame-type ethernet</code>	Configures the frame type. Currently, only Ethernet frames are supported. The frame type defaults to Ethernet.



Note

The port number for the 100VG-AnyLAN port adapter is always 0.

Configuring the PA-100VG interface is similar to configuring an Ethernet or Fast Ethernet interface. To display information about the 100VG-AnyLAN port adapter, use the **show interfaces vg-anylan EXEC** command.

Configuring Fast EtherChannel

The Fast EtherChannel feature allows multiple Fast Ethernet point-to-point links to be bundled into one logical link to provide bidirectional bandwidth of up to 800 Mbps. Fast EtherChannel builds on standards-based 802.3 full-duplex Fast Ethernet to provide fault-tolerant, high-speed links between switches, routers, and servers. This feature can be configured between Cisco 7500 series routers and Cisco 7000 series routers with the 7000 Series Route Switch Processor (RSP7000) and 7000 Series Chassis Interface (RSP7000CI) or between a Cisco 7500 series router or a Cisco 7000 series router with the RSP7000 and RSP7000CI and a Catalyst 5000 switch.



Note

Using the Fast EtherChannel feature on a Catalyst 5000 switch requires a hardware upgrade. Contact your local sales representative for upgrade details.

Fast EtherChannel provides higher bidirectional bandwidth, redundancy, and load sharing. Up to four Fast Ethernet interfaces can be bundled in a port-channel, and the router or switch can support up to four port-channels. The Fast EtherChannel feature is capable of load balancing traffic across the Fast Ethernet

links. Unicast, broadcast, and multicast traffic is distributed across the links providing higher performance and redundant parallel paths. In the event of a link failure, traffic is redirected to remaining links within the Fast EtherChannel without user intervention.

In this release of the Fast EtherChannel feature, IP traffic is distributed over the port-channel interface while traffic from other routing protocols is sent over a single link. Bridged traffic is distributed based on the Layer 3 information in the packet. If the Layer 3 information does not exist in the packet, the traffic is sent over the first link.

Fast EtherChannel supports all features currently supported on the Fast Ethernet interface. You must configure these features on the port-channel interface rather than on the individual Fast Ethernet interfaces. Fast EtherChannel connections are fully compatible with Cisco IOS virtual LAN (VLAN) and routing technologies. The Inter-Switch Link (ISL) VLAN trunking protocol can carry multiple VLANs across a Fast EtherChannel, and routers attached to Fast EtherChannel links can provide full multiprotocol routing with support for host standby using Host Standby Router Protocol (HSRP).

The port-channel (consisting of up to four Fast Ethernet interfaces) is treated as a single interface. Port-channel is used in the Cisco IOS software to maintain compatibility with existing commands on the Catalyst 5000 switch. You create the Fast EtherChannel by using the **interface port-channel** interface configuration command. You can assign up to four Fast Ethernet interfaces to a port-channel by using the **channel-group** interface configuration command.

Fast EtherChannel also supports the following two features:

- Support for host standby using Host Standby Router Protocol (HSRP)
For more information about configuring HSRP, refer to the “Configuring IP Services” chapter in the *Cisco IOS IP and IP Routing Configuration Guide*.
- Support for Cisco Express Forwarding (CEF) and distributed CEF (dCEF)
For more information about configuring CEF, refer to the “Cisco Express Forwarding” chapter in the *Cisco IOS Switching Services Configuration Guide*.

For information on how to configure Ethernet or Fast Ethernet, see the tasks listed in the “Configuring an Ethernet or Fast Ethernet Interface” section.

Fast EtherChannel Configuration Task List

Perform the tasks in the following sections to configure Fast EtherChannel. To configure Fast EtherChannel, perform the following required steps:

1. Create a port-channel interface and assign an IP address.
2. Assign the Fast Ethernet interfaces (up to four) to the port-channel interface.

For information on other configuration tasks for the Fast EtherChannel, see the “Configuring an Ethernet or Fast Ethernet Interface” section.

For information on other commands that can be used by the Fast EtherChannel, refer to the other configuration guides in the Cisco IOS documentation set.

Configuring the Port-Channel Interface

To configure the port-channel interface, use the following commands beginning in global configuration mode:

	Command	Purpose
Step 1	<code>interface port-channel channel-number</code>	Creates the port-channel interface and enters interface configuration mode. The channel number can be 1 to 4.
Step 2	<code>ip address ip-address mask</code>	Assigns an IP address and subnet mask to the Fast EtherChannel. If you configure ISL, you must assign the IP address to the subinterface (for example, interface port-channel 1.1—an IP address per VLAN) and you must specify the encapsulation with VLAN number under that subinterface (for example, encapsulation isl 100).
Step 3	<code>mac-address ieee-address</code>	(Optional) Assigns a static MAC address to the Fast EtherChannel. If you do not assign a static MAC address on the port-channel interface, the Cisco IOS software automatically assigns a MAC address. If you assign a static MAC address and then later remove it, the Cisco IOS software automatically assigns a MAC address.
Step 4	<code>end</code>	(Optional) Enables other supported interface commands to execute, and exits when they have finished.
Step 5	<code>show interface port-channel</code>	Displays information about the port-channel interface so you can verify the configuration.



Note

If you want to use the Cisco Discovery Protocol (CDP), you must configure it on the physical Ethernet, Fast Ethernet, or GigabitEthernet interface, not on the port-channel interface.



Caution

With Release 11.1(20)CC and later, Fast EtherChannel supports CEF/dCEF. We recommend that you clear all explicit **ip route-cache distributed** commands from the Fast Ethernet interfaces before enabling dCEF on the port-channel interface. Doing this gives the port-channel interface proper control of its physical Fast Ethernet links. When you enable CEF/dCEF globally, all interfaces that support CEF/dCEF are enabled. When CEF/dCEF is enabled on the port-channel interface, it is automatically enabled on each of the Fast Ethernet interfaces in the channel group. However, if you have previously disabled CEF/dCEF on the Fast Ethernet interface, CEF/dCEF is not automatically enabled. In this case, you must enable CEF/dCEF on the Fast Ethernet interface.

Configuring the Fast Ethernet Interfaces

To assign the Fast Ethernet interfaces to the Fast EtherChannel, use the following commands beginning in global configuration mode:

	Command	Purpose
Step 1	interface fastethernet <i>slot/port-adapter/port</i>	Creates or modifies an existing Fast Ethernet interface and enters interface configuration mode.
Step 2	no ip address	Disables the IP address before performing the next step, if the Fast Ethernet interface already exists and has an IP address assigned.
Step 3	channel-group <i>channel-number</i>	Assigns the Fast Ethernet interfaces to the Fast EtherChannel. The channel number is the same as the channel number you specified when you created the port-channel interface.
Step 4	exit	Exits interface configuration mode. Repeat Steps 1 through 4 to add up to four Fast Ethernet interfaces to the Fast EtherChannel.
Step 5	end	(Optional) Enables other supported interface commands to execute, and exits when they have finished.
Step 6	show interface port-channel	Displays information about the Fast Ethernet interface so you can verify the configuration.



Caution

The port-channel interface is the routed interface. Do not enable Layer 3 addresses on the physical Fast Ethernet interfaces. Do not assign bridge groups on the physical Fast Ethernet interfaces because it creates loops. Also, you must disable spanning tree.

To remove a Fast Ethernet interface from a Fast EtherChannel, use the following commands beginning in global configuration mode:

	Command	Purpose
Step 1	interface fastethernet <i>slot/port-adapter/port</i>	Specifies the Fast Ethernet interface and enters interface configuration mode.
Step 2	no channel-group	Removes the Fast Ethernet interface from the channel group.
Step 3	end	(Optional) Enables other supported interface commands to execute, and exits when they have finished.

The Cisco IOS software automatically removes a Fast Ethernet interface from the Fast EtherChannel if the interface goes down, and the software automatically adds the Fast Ethernet interface to the Fast EtherChannel when the interface is back up.

Currently, Fast EtherChannel relies on keepalives to detect whether the line protocol is up or down. Keepalives are enabled by default on the Fast Ethernet interfaces. If the line protocol on the interface goes down because it did not receive a keepalive signal, the Fast EtherChannel detects that the line protocol is down and removes the interface from the Fast EtherChannel. However, if the line protocol remains up because keepalives are disabled on the Fast Ethernet interface, the Fast EtherChannel cannot detect this link failure (other than a cable disconnect) and does not remove the interface from the Fast

EtherChannel even if the line protocol goes down. This can result in unpredictable behavior. The implementation of the Port Aggregation Protocol in a subsequent release of this feature will remove the dependency on keepalives.

See the “LAN Interface Configuration Examples” section for configuration examples.

You can monitor the status of the Fast EtherChannel interface by using the **show interfaces port-channel EXEC** command.

Configuring a Fiber Distributed Data Interface

The Fiber Distributed Data Interface (FDDI) is an ANSI-defined standard for timed 100-Mbps token passing over fiber-optic cable. FDDI is not supported on access servers.

An FDDI network consists of two counter-rotating, token-passing fiber-optic rings. On most networks, the primary ring is used for data communication and the secondary ring is used as a hot standby. The FDDI standard sets a total fiber length of 200 kilometers. (The maximum circumference of the FDDI network is only half the specified kilometers because of the *wrapping* or looping back of the signal that occurs during fault isolation.)

The FDDI standard allows a maximum of 500 stations with a maximum distance between active stations of two kilometers when interconnecting them with multimode fiber or ten kilometers when interconnected via single mode fiber, both of which are supported by our FDDI interface controllers. The FDDI frame can contain a minimum of 17 bytes and a maximum of 4500 bytes. Our implementation of FDDI supports Station Management (SMT) Version 7.3 of the X3T9.5 FDDI specification, offering a single MAC dual-attach interface that supports the fault-recovery methods of the dual attachment stations (DASS). The mid-range platforms also support single attachment stations (SASs).

Refer to the *Cisco Product Catalog* for specific information on platform and interface compatibility. For installation and configuration information, refer to the installation and configuration publication for the appropriate interface card or port adapter.

Source-Route Bridging over FDDI on Cisco 4000-M, Cisco 4500-M, and Cisco 4700-M Routers

Source-route bridging (SRB) is supported on the FDDI interface to the Cisco 4000-M, Cisco 4500-M, and Cisco 4700-M routers. For instructions on configuring autonomous FDDI SRB or fast-switching SRB over FDDI, refer to the “Configuring Source-Route Bridging” chapter of the *Cisco IOS Bridging and IBM Networking Configuration Guide*.

Particle-Based Switching of Source-Route Bridge Packets on Cisco 7200 Series Routers

Source-route bridging (SRB) is supported over Fiber Distributed Data Interface (FDDI).

Particle-based switching is supported for SRB packets (over FDDI and Token Ring) by default.

Particle-based switching adds scatter-gather capability to SRB to improve performance. Particles represent a communications data packet as a collection of noncontiguous buffers. The traditional Cisco IOS packet has a packet type control structure and a single contiguous data buffer. A particle packet has the same packet type control structure, but also maintains a queue of particle type structures, each of which manages its own block.

The scatter-gather architecture used by particle-based switching provides the following advantages:

- Allows drivers to use memory more efficiently (especially when using media that has a large maximum transmission unit [MTU]). For example, Token Ring buffers could be 512 bytes rather than 16 KB.
- Allows concurrent use of the same region of memory. For example, on IP multicast a single packet is received and sent out on multiple interfaces simultaneously.
- Allows insertion or deletion of memory at any location in a packet (not just at the beginning or end).

For information about configuring SRB over FDDI, refer to the “Configuring Source-Route Bridging” chapter of the *Cisco IOS Bridging and IBM Networking Configuration Guide*.

Using Connection Management Information

Connection management (CMT) is an FDDI process that handles the transition of the ring through its various states (off, on, active, connect, and so on) as defined by the X3T9.5 specification. The FIP provides CMT functions in microcode.

A partial sample output of the **show interfaces fddi** command follows, along with an explanation of how to interpret the CMT information in the output.

```
Phy-A state is active, neighbor is B, cmt signal bits 08/20C, status ALS
Phy-B state is active, neighbor is A, cmt signal bits 20C/08, status ILS
CFM is thru A, token rotation 5000 usec, ring operational 0:01:42
Upstream neighbor 0800.2008.C52E, downstream neighbor 0800.2008.C52E
```

The **show interfaces fddi** example shows that Physical A (Phy-A) completed CMT with its neighbor. The state is active and the display indicates a Physical B-type neighbor.

The sample output indicates CMT signal bits 08/20C for Phy-A. The transmit signal bits are 08. Looking at the PCM state machine, 08 indicates that the port type is A, the port compatibility is set, and the LCT duration requested is short. The receive signal bits are 20C, which indicate the neighbor type is B, port compatibility is set, there is a MAC on the port output, and so on.

The neighbor is determined from the received signal bits, as follows:

Bit Positions	9	8	7	6	5	4	3	2	1	0
Value Received	1	0	0	0	0	0	1	1	0	0

Interpreting the bits in the diagram above, the received value equals 0x20C. Bit positions 1 and 2 (0 1) indicate a Physical B-type connection.

The transition states displayed indicate that the CMT process is running and actively trying to establish a connection to the remote physical connection. The CMT process requires state transition with different signals being transmitted and received before moving on to the state ahead as indicated in the PCM state machine. The ten bits of CMT information are transmitted and received in the Signal State. The NEXT state is used to separate the signaling performed in the Signal State. Therefore, in the preceding sample output, the NEXT state was entered 11 times.



Note

The display line showing transition states is not generated if the FDDI interface has been shut down, or if the **cmt disconnect** command has been issued, or if the **fddi if-cmt** command has been issued. (The **fddi if-cmt** command applies to the Cisco 7500 series routers only.)

The CFM state is through A in the sample output, which means this interface's Phy-A has successfully completed CMT with the Phy-B of the neighbor and Phy-B of this interface has successfully completed CMT with the Phy-A of the neighbor.

The display (or nondisplay) of the upstream and downstream neighbor does not affect the ability to route data. Since the upstream neighbor is also its downstream neighbor in the sample, there are only two stations in the ring: the network server and the router at address 0800.2008.C52E.

FDDI Configuration Task List

Perform the tasks in the following sections to configure an FDDI interface:

- Specifying a FDDI (Required)
- Enabling FDDI Bridging Encapsulation (Optional)
- Enabling Full-Duplex Mode on the FDDI (Optional)
- Setting the Token Rotation Time (Optional)
- Setting the Transmission Valid Timer (Optional)
- Controlling the Transmission Timer (Optional)
- Modifying the C-Min Timer (Optional)
- Modifying the TB-Min Timer (Optional)
- Modifying the FDDI Timeout Timer (Optional)
- Controlling SMT Frame Processing (Optional)
- Enabling Duplicate Address Checking (Optional)
- Setting the Bit Control (Optional)
- Controlling the CMT Microcode (Optional)
- Starting and Stopping FDDI (Optional)
- Setting FDDI Frames Per Token Limit (Optional)
- Controlling the FDDI SMT Message Queue Size (Optional)
- Preallocating Buffers for Bursty FDDI Traffic (Optional)

Specifying a FDDI

To specify an FDDI interface and enter interface configuration mode, use one of the following commands in global configuration mode:

Command	Purpose
<code>interface fddi <i>number</i></code>	Begins interface configuration.
<code>interface fddi <i>slot/port</i></code>	Begins interface configuration for the Cisco 7200 or Cisco 7500 series routers.

Enabling FDDI Bridging Encapsulation

Cisco FDDI by default uses the SNAP encapsulation format defined in RFC 1042. It is not necessary to define an encapsulation method for this interface when using the FIP.

FIP fully supports transparent and translational bridging for the following configurations:

- FDDI-to-FDDI
- FDDI-to-Ethernet
- FDDI-to-Token Ring

Enabling FDDI bridging encapsulation places the FIP into encapsulation mode when doing bridging. In transparent mode, the FIP interoperates with earlier versions of encapsulating interfaces when performing bridging functions on the same ring. When using the FIP, you can specify the encapsulation method by using the following command in interface configuration mode:

Command	Purpose
<code>fddi encapsulate</code>	Specifies the encapsulation method for the FIP.

When you are doing translational bridging, use routing for routable protocols and use translational bridging for the rest (such as LAT).



Note

Bridging between dissimilar media presents several problems that can prevent communications. These problems include bit-order translation (using MAC addresses as data), maximum transfer unit (MTU) differences, frame status differences, and multicast address usage. Some or all of these problems might be present in a multimedia-bridged LAN and might prevent communication. These problems are most prevalent in networks that bridge between Token Rings and Ethernet networks or between Token Rings and FDDI because of the different ways Token Ring is implemented by the end nodes.

We are currently aware of problems with the following protocols when bridged between Token Ring and other media: AppleTalk, DECnet, IP, Novell IPX, Phase IV, VINES, and XNS. Further, the following protocols might have problems when bridged between FDDI and other media: Novell IPX and XNS. We recommend that these protocols be routed whenever possible.

Enabling Full-Duplex Mode on the FDDI

To enable full-duplex mode on the PA-F/FD-SM and PA-F/FD-MM port adapters, use one of the following commands in interface configuration mode:

Command	Purpose
<code>full-duplex</code>	Enables full-duplex on the FDDI interface of the PA-F/FD-SM and PA-F/FD-MM port adapter.
or	
<code>no half-duplex</code>	

Setting the Token Rotation Time

You can set the FDDI token rotation time to control ring scheduling during normal operation and to detect and recover from serious ring error situations. To do so, use the following command in interface configuration mode:

Command	Purpose
<code>fddi token-rotation-time <i>microseconds</i></code>	Sets the FDDI token rotation time.

The FDDI standard restricts the allowed time to be greater than 4000 microseconds and less than 165,000 microseconds. As defined in the X3T9.5 specification, the value remaining in the token rotation timer (TRT) is loaded into the token holding timer (THT). Combining the values of these two timers provides the means to determine the amount of bandwidth available for subsequent transmissions.

Setting the Transmission Valid Timer

You can set the transmission timer to recover from a transient ring error by using the following command in interface configuration mode:

Command	Purpose
<code>fddi valid-transmission-time <i>microseconds</i></code>	Sets the FDDI valid transmission timer.

Controlling the Transmission Timer

You can set the FDDI control transmission timer to control the FDDI TL-Min time, which is the minimum time to transmit a Physical Sublayer or PHY line state before advancing to the next Physical Connection Management or PCM state as defined by the X3T9.5 specification. To do so, use the following command in interface configuration mode:

Command	Purpose
<code>fddi t1-min-time <i>microseconds</i></code>	Sets the FDDI control transmission timer.

Modifying the C-Min Timer

You can modify the C-Min timer on the PCM from its default value of 1600 microseconds by using the following command in interface configuration mode:

Command	Purpose
<code>fddi c-min <i>microseconds</i></code>	Sets the C-Min timer on the PCM.

Modifying the TB-Min Timer

You can change the TB-Min timer in the PCM from its default value of 100 ms. To do so, use the following command in interface configuration mode:

Command	Purpose
<code>fddi tb-min milliseconds</code>	Sets TB-Min timer in the PCM.

Modifying the FDDI Timeout Timer

You can change the FDDI timeout timer in the PCM from its default value of 100 ms. To do so, use the following command in interface configuration mode:

Command	Purpose
<code>fddi t-out milliseconds</code>	Sets the timeout timer in the PCM.

Controlling SMT Frame Processing

You can disable and enable SMT frame processing for diagnostic purposes. To do so, use one of the following commands in interface configuration mode:

Command	Purpose
<code>no fddi smt-frames</code>	Disables SMT frame processing.
<code>fddi smt-frames</code>	Enables SMT frame processing.

Enabling Duplicate Address Checking

You can enable the duplicate address detection capability on the FDDI. If the FDDI finds a duplicate address, it displays an error message and shuts down the interface. To enable duplicate address checking, use the following command in interface configuration mode:

Command	Purpose
<code>fddi duplicate-address-check</code>	Enables duplicate address checking capability.

Setting the Bit Control

You can set the FDDI bit control to control the information transmitted during the Connection Management (CMT) signaling phase. To do so, use the following command in interface configuration mode:

Command	Purpose
<code>fddi cmt-signal-bits signal-bits [phy-a phy-b]</code>	Sets the FDDI bit control.

Controlling the CMT Microcode

You can control whether the CMT onboard functions are on or off. The FIP provides CMT functions in microcode. These functions are separate from those provided on the processor card and are accessed through EXEC commands.

The default is for the FIP CMT functions to be on. A typical reason to disable is when you work with new FDDI equipment and have problems bringing up the ring. If you disable the CMT microcode, the following actions occur:

- The FIP CMT microcode is disabled.
- The main system code performs the CMT function while debugging output is generated.

To disable the CMT microcode, use the following command in interface configuration mode:

Command	Purpose
<code>no fddi if-cmt</code>	Disables the FCIT CMT functions.

Starting and Stopping FDDI

In normal operation, the FDDI interface is operational once the interface is connected and configured. You can start and stop the processes that perform the CMT function and allow the ring on one fiber to be stopped. To do so, use either of the following commands in EXEC mode:

Command	Purpose
<code>cmt connect [interface-name [phy-a phy-b]]</code>	Starts CMT processes on FDDI ring.
<code>cmt disconnect [interface-name [phy-a phy-b]]</code>	Stops CMT processes on FDDI ring.

Do not use either of the preceding commands during normal operation of FDDI; they are used during interoperability tests.

Setting FDDI Frames Per Token Limit

The FDDI interface is able to transmit multiple frames per token on a Cisco 4000, Cisco 4500, and a Cisco 4700 series routers, instead of only a single frame at a time. You can specify the maximum number of frames to be transmitted with each token capture. This significantly improves your throughput, when you have heavy or very bursty traffic.

To configure the FDDI interface to transmit a maximum number of frames per token capture, use the following commands:

	Command	Purpose
Step 1	<code>configure terminal</code>	Enters global configuration mode.
Step 2	<code>interface fddi0</code>	Enters interface configuration mode.
Step 3	<code>fddi ?</code>	Shows fddi command options.
Step 4	<code>fddi frames-per-token ?</code>	Shows fddi frames-per-token command options.
Step 5	<code>fddi frames-per-token number</code>	Specifies the maximum number of frames to be transmitted per token capture.

Controlling the FDDI SMT Message Queue Size

You can set the maximum number of unprocessed FDDI Station Management (SMT) frames that will be held for processing. Setting this number is useful if the router you are configuring gets bursts of messages arriving faster than the router can process them. To set the number of frames, use the following command in global configuration mode:

Command	Purpose
<code>smt-queue-threshold</code> <i>number</i>	Sets SMT message queue size.

Preallocating Buffers for Bursty FDDI Traffic

The FCI card preallocates three buffers to handle bursty FDDI traffic (for example, NFS bursty traffic). You can change the number of preallocated buffers by using the following command in interface configuration mode:

Command	Purpose
<code>fddi burst-count</code>	Preallocates buffers to handle bursty FDDI traffic.

Configuring a Hub Interface

The Cisco 2500 series routers includes routers that have hub functionality for an Ethernet interface. The hub is a multiport repeater. The advantage of an Ethernet interface over a hub is that the hub provides a star-wiring physical network configuration while the Ethernet interface provides 10BASE-T physical network configuration. The router models with hub ports and their configurations are as follows:

- Cisco 2505—1 Ethernet (8 ports) and 2 serial
- Cisco 2507—1 Ethernet (16 ports) and 2 serial
- Cisco 2516—1 Ethernet (14 ports), 2 serial, and 1 ISDN BRI

We provide SNMP management of the Ethernet hub as specified in RFC 1516, “Definitions of Managed Objects for IEEE 802.3 Repeater Devices.”

To configure hub functionality on an Ethernet interface, perform the tasks in the following sections:

- Enabling a Hub Port (Required)
- Disabling or Enabling Automatic Receiver Polarity Reversal (Optional)
- Disabling or Enabling the Link Test Function (Optional)
- Enabling Source Address Control (Optional)
- Enabling SNMP Illegal Address Trap (Optional)

For configuration examples, see the “Hub Configuration Examples” section.

Enabling a Hub Port

To enable a hub port, use the following commands in global configuration mode:

	Command	Purpose
Step 1	<code>hub ethernet number port [end-port]</code>	Specifies the hub number and the hub port (or range of hub ports) and enters hub configuration mode.
Step 2	<code>no shutdown</code>	Enables the hub ports.

Disabling or Enabling Automatic Receiver Polarity Reversal

On Ethernet hub ports only, the hub ports can invert, or correct, the polarity of the received data if the port detects that the received data packet waveform polarity is reversed due to a wiring error. This receive circuitry polarity correction allows the hub to repeat subsequent packets with correct polarity. When enabled, this function is executed once after reset of a link fail state.

Automatic receiver polarity reversal is enabled by default. To disable this feature on a per-port basis, use the following command in hub configuration mode:

Command	Purpose
<code>no auto-polarity</code>	Disables automatic receiver polarity reversal.

To enable automatic receiver polarity reversal on a per-port basis, use the following command in hub configuration mode:

Command	Purpose
<code>auto-polarity</code>	Enables automatic receiver polarity reversal.

Disabling or Enabling the Link Test Function

The link test function applies to Ethernet hub ports only. The Ethernet ports implement the link test function as specified in the 802.3 10BASE-T standard. The hub ports will transmit link test pulses to any attached twisted pair device if the port has been inactive for more than 8 to 17 ms.

If a hub port does not receive any data packets or link test pulses for more than 65 to 132 ms and the link test function is enabled for that port, that port enters link fail state and cannot transmit or receive. The hub port is enabled again when it receives four consecutive link test pulses or a data packet.

The link test function is enabled by default. To allow the hub to interoperate with 10BASE-T twisted-pair networks that do not implement the link test function, the hub's link test receive function can be disabled on a per-port basis. To do so, use the following command in hub configuration mode:

Command	Purpose
<code>no link-test</code>	Disables the link test function.

To enable the link test function on a hub port connected to an Ethernet interface, use the following command in hub configuration mode:

Command	Purpose
<code>link-test</code>	Enables the link test function.

Enabling Source Address Control

On an Ethernet hub port only, you can configure a security measure such that the port accepts packets only from a specific MAC address. For example, suppose your workstation is connected to port 3 on a hub, and source address control is enabled on port 3. Your workstation has access to the network because the hub accepts any packet from port 3 with your workstation's MAC address. Any packets arriving with a different MAC address cause the port to be disabled. The port is enabled again after 1 minute and the MAC address of incoming packets is checked again.

To enable source address control on a per-port basis, use the following command in hub configuration mode:

Command	Purpose
<code>source-address</code> [<i>mac-address</i>]	Enables source address control.

If you omit the optional MAC address, the hub remembers the first MAC address it receives on the selected port, and allows only packets from the learned MAC address.

See the examples of establishing source address control in the “Hub Configuration Examples” section.

Enabling SNMP Illegal Address Trap

To enable the router to issue an SNMP trap when an illegal MAC address is detected on an Ethernet hub port, use the following commands in hub configuration mode:

	Command	Purpose
Step 1	<code>hub ethernet</code> <i>number port</i> [<i>end-port</i>]	Specifies the hub number and the hub port (or range of hub ports) and enters hub configuration mode.
Step 2	<code>snmp trap illegal-address</code>	Enables the router to issue an SNMP trap when an illegal MAC address is detected on the hub port.

You may need to set up a host receiver for this trap type (snmp-server host) for a Network Management System (NMS) to receive this trap type. The default is no trap. For an example of configuring a SNMP trap for an Ethernet hub port, see the “Hub Configuration Examples” section.

Configuring a LAN Extender Interface

The Cisco 1001 and Cisco 1002 LAN Extenders are two-port chassis that connect a remote Ethernet LAN to a core router at a central site (see Figure 3). The LAN Extender is intended for small networks at remote sites. Overview information for LAN extender interfaces is provided in these sections:

- Connecting a LAN Extender to a Core Router
- Installing a LAN Extender at a Remote Site
- Discovering the MAC Address
- Upgrading Software for the LAN Extender
- Configuring the LAN Extender

For examples of LAN Extender interface configuration tasks, see the “LAN Extender Interface Configuration Task List” section.

Connecting a LAN Extender to a Core Router

The remote site can have one Ethernet network. The core router can be a Cisco 2500 series, Cisco 4000 series, Cisco 4500 series, Cisco 4700 series, Cisco 7500 series, or AGS+ router running Cisco IOS Release 10.2(2) and later, which support the LAN Extender host software.

Figure 3 shows the connection between the LAN Extender and the core router via a short leased serial line, typically a 56-kbps or 64-kbps line. However, the connection can also be via T1 or E1 lines.

Figure 3 Cisco 1000 Series LAN Extender Connection to a Core Router

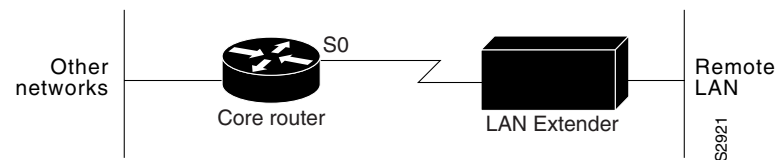

Expanded View of the Connection to a Core Router

Figure 4 is an expanded view of Figure 3 that shows all the components of the LAN Extender connection to a core router. On the left is the core router, which is connected to the LAN Extender as well as to other networks. In the core router, you configure a LAN Extender interface, which is a logical interface that connects the core router to the LAN Extender chassis. In the core router, you also configure a serial interface, which is the physical interface that connects the core router to the LAN Extender. You then bind, or associate, the LAN Extender interface to the physical serial interface.

Figure 4 shows the actual physical connection between the core router and the LAN Extender. The serial interface on the core router is connected by a leased serial line to a serial port on the LAN Extender. This creates a virtual Ethernet connection, which is analogous to having inserted an Ethernet interface processor into the core router.

Figure 4 Expanded View of Cisco 1000 Series LAN Extender Connection

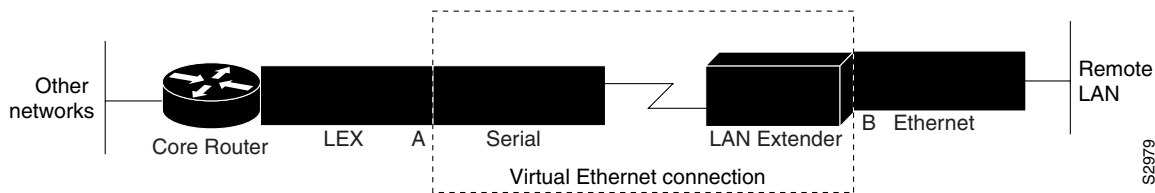

Management of the LAN Extender Interface

Although there is a physical connection between the core router and the LAN Extender, what you actually manage is a remote Ethernet LAN. Figure 5 shows the connection you are managing, which is a LAN Extender interface connected to an Ethernet network. The virtual Ethernet connection (the serial interface and LAN Extender) has been removed from the figure, and points A and B, which in Figure 4 were separated by the virtual Ethernet connection, are now adjacent. All LAN Extender interface configuration tasks described in this chapter apply to the interface configuration shown in Figure 5.

Figure 5 LAN Extender Interface Connected to an Ethernet Network



Installing a LAN Extender at a Remote Site

To install a LAN Extender at a remote site, refer to the *Cisco 1000 Series Hardware Installation* publication.

Discovering the MAC Address

After the LAN Extender has been installed at the remote site, you need to obtain its MAC address. Each LAN Extender is preconfigured with a permanent (burned-in) MAC address. The address is assigned at the factory; you cannot change it. The MAC address is printed on the LAN Extender's packing box. (If necessary, you can also display the MAC address with the **debug ppp negotiation** command.) The first three octets of the MAC address (the vendor code) are always the hexadecimal digits 00.00.0C.

Upgrading Software for the LAN Extender

You can upgrade software for the LAN Extender on the host router with a TFTP server that is local to the host router.

The LAN Extender and core router communicate using the Point-to-Point Protocol (PPP). Before you can configure the LAN Extender from the core router, you must first enable PPP encapsulation on the serial interface to which the LAN Extender is connected.

Configuring the LAN Extender

You configure the LAN Extender from the core router—either a Cisco 4000 series or Cisco 7000 series router—as if it were simply a network interface board. The LAN Extender cannot be managed or configured from the remote Ethernet LAN or via a Telnet session.

To configure the LAN Extender, you configure a logical LAN Extender interface on the core router and assign the MAC address from your LAN Extender to that interface. Subsequently, during the PPP negotiation on the serial line, the LAN Extender sends its preconfigured MAC address to the core router. The core router then searches for an available (preconfigured) LAN Extender interface, seeking one to which you have already assigned that MAC address. If the core router finds a match, it binds, or associates, that LAN Extender interface to the serial line on which that MAC address was negotiated. At this point, the LAN Extender interface is created and is operational. If the MAC address does not match one that is configured, the connection request is rejected. Figure 6 illustrates this binding process.

Figure 6 Binding a Serial Line to a LAN Extender Interface

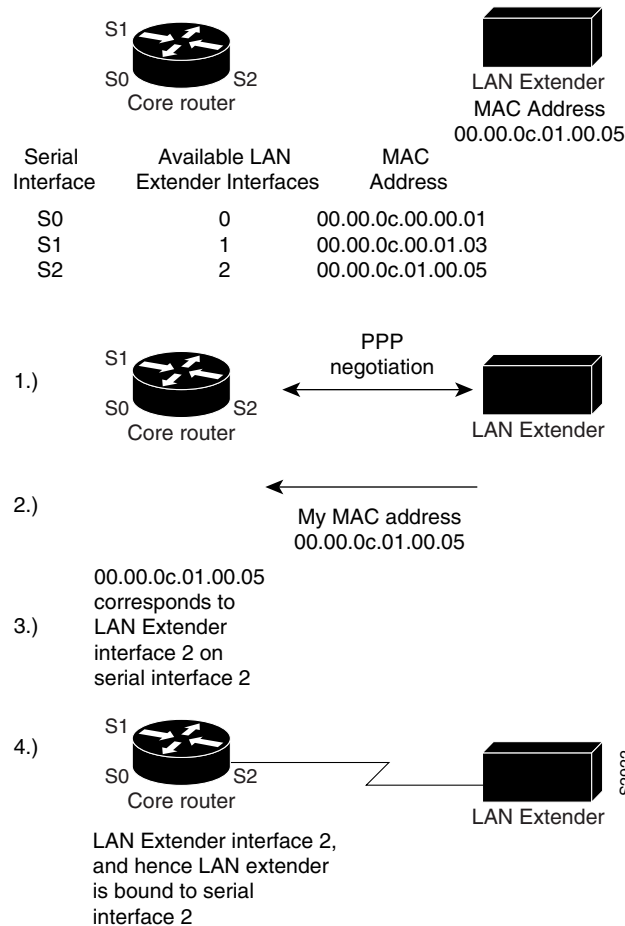

LAN Extender Interface Configuration Task List

To configure a LAN Extender interface, perform the tasks described in the following sections:

- Configuring and Creating a LAN Extender Interface (Required)
- Defining Packet Filters (Optional)
- Controlling Priority Queueing (Optional)
- Controlling the Sending of Commands to the LAN Extender (Optional)
- Shutting Down and Restarting the LAN Extender's Ethernet Interface (Optional)
- Restarting the LAN Extender (Optional)
- Downloading a Software Image to the LAN Extender (Optional)
- Troubleshooting the LAN Extender (Optional)

To monitor the LAN Extender interface, see the “Monitoring and Maintaining the Interface” section in the “Interface Configuration Overview” chapter. For configuration examples, see the “LAN Extender Enablement Interface Example” and the “LAN Extender Interface Access List Examples” sections.

Configuring and Creating a LAN Extender Interface

To configure and create a LAN Extender interface, you configure the LAN Extender interface itself and the serial interface to which the LAN Extender is physically connected. The order in which you configure these two interface interfaces does not matter. However, you must first configure both interfaces in order for the LAN Extender interface to bind (associate) to the serial interface.

To create and configure a LAN Extender interface, use the following commands starting in interface configuration mode:

	Command	Purpose
Step 1	<code>interface lex number</code> <code>interface lex slot/port</code>	Configures a LAN Extender interface in global configuration mode and enters interface configuration mode. or Configures a LAN Extender on a Cisco 7000 series routers.
Step 2	<code>lex burned-in-address ieee-address</code>	Assigns the burned-in MAC address from your LAN Extender to the LAN Extender interface.
Step 3	<code>ip address ip-address mask</code>	Assigns a protocol address to the LAN Extender interface.
Step 4	<code>exit</code>	Returns to global configuration mode.
Step 5	<code>interface serial number</code>	Configures a serial interface in global configuration mode and enters interface configuration mode.
Step 6	<code>encapsulation ppp</code>	Enables PPP encapsulation on the serial interface in interface configuration mode.
Step 7	<code>Ctrl-Z</code>	Exits interface configuration mode.
Step 8	<code>copy system:running-config nvram:startup-config</code>	Saves the configuration to memory.

Note that there is no correlation between the number of the serial interface and the number of the LAN Extender interface. These interfaces can have the same or different numbers.



Note

Do not configure the MTU to a value other than the default value when you are configuring a LAN Extender interface.

Defining Packet Filters

You can configure specific administrative filters that filter frames based on their source MAC address. The LAN Extender forwards packets between a remote LAN and a core router. It examines frames and transmits them through the internetwork according to the destination address, and it does not forward a frame back to its originating network segment.

You define filters on the LAN Extender interface in order to control which packets from the remote Ethernet LAN are permitted to pass to the core router (see Figure 7). These filters are applied only on traffic passing from the remote LAN to the core router. Filtering on the LAN Extender interface is actually performed in the LAN Extender, not on the core router. This means that the filtering is done using the LAN Extender CPU, thus offloading the function from the core router. This process also saves bandwidth on the WAN, because only the desired packets are forwarded from the LAN Extender to the core router. Whenever possible, you should perform packet filtering on the LAN Extender.

Figure 7 Packet Filtering on the LAN Extender

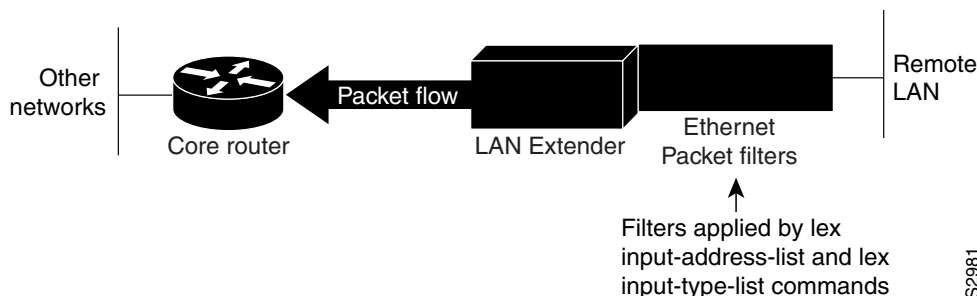

You can also define filters on the core router to control which packets from the LAN Extender interface are permitted to pass to other interfaces on the core router (see Figure 8). You do this using the standard filters available on the router. This means that all packets are sent across the WAN before being filtered and that the filtering is done using the core router’s CPU.

Figure 8 Packet Filtering on the Core Router

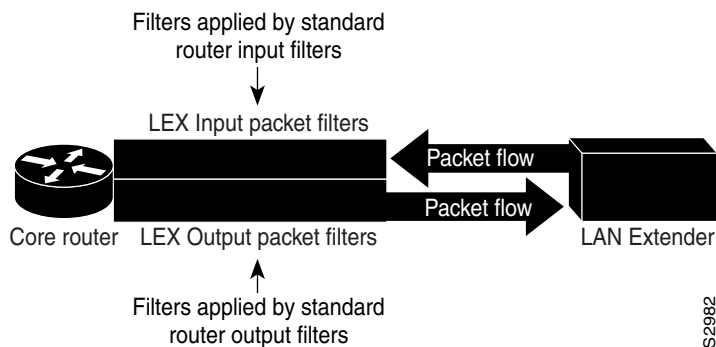

The major reason to create access lists on a LAN Extender interface is to prevent traffic that is local to the remote Ethernet LAN from traversing the WAN and reaching the core router. You can filter packets by MAC address, including vendor code, and by Ethernet type code. To define filters on the LAN Extender interface, perform the tasks described in one or both of the following sections:

- Filtering by MAC Address and Vendor Code
- Filtering by Protocol Type

**Note**

When setting up administrative filtering, remember that there is virtually no performance penalty when filtering by vendor code, but there can be a performance penalty when filtering by protocol type.

When defining access lists, keep the following points in mind:

- You can assign only one vendor code access list and only one protocol type access list to an interface.
- The conditions in the access list are applied to all outgoing packets from the LAN Extender.
- The entries in an access list are scanned in the order you enter them. The first entry that matches the outgoing packet is used.
- An implicit “deny everything” entry is automatically defined at the end of an access list unless you include an explicit “permit everything” entry at the end of the list. This means that unless you have an entry at the end of an access list that explicitly permits all packets that do not match any of the other conditions in the access list, these packets will not be forwarded out the interface.
- All new entries to an existing list are placed at the end of the list. You cannot add an entry to the middle of a list.
- If you do not define any access lists on an interface, it is as if you had defined an access list with only a “permit all” entry. All traffic passes across the interface.

Filtering by MAC Address and Vendor Code

You can create access lists to administratively filter MAC addresses. These access lists can filter groups of MAC addresses, including those with particular vendor codes. There is no noticeable performance loss in using these access lists, and the lists can be of indefinite length.

You can filter groups of MAC addresses with particular vendor codes by creating a vendor code access list and then by applying an access list to an interface.

To create a vendor code access list, use the following command in global configuration mode:

Command	Purpose
<code>access-list <i>access-list-number</i> {permit deny} <i>address mask</i></code>	Creates an access list to filter frames by canonical (Ethernet-ordered) MAC address.

**Note**

Token Ring and FDDI networks swap their MAC address bit ordering, but Ethernet networks do not. Therefore, an access list that works for one medium might not work for others.

Once you have defined an access list to filter by a particular vendor code, you can assign this list to a particular LAN Extender interface so that the interface will then filter based on the MAC source addresses of packets received on that LAN Extender interface. To apply the access list to an interface, use the following command in interface configuration mode:

Command	Purpose
<code>lex input-address-list access-list-number</code>	Assigns an access list to an interface for filtering by MAC source addresses.

For an example of creating an access list and applying it to a LAN Extender interface, see the “LAN Extender Interface Access List Examples” section.

Filtering by Protocol Type

You can filter by creating a type-code access list and applying it to a LAN Extender interface.

The LAN Extender interface can filter only on bytes 13 and 14 of the Ethernet frame. In Ethernet packets, these two bytes are the type field. For a list of Ethernet type codes, refer to the “Ethernet Type Codes” appendix in the *Cisco IOS Bridging and IBM Networking Command Reference, Volume 1*. In 802.3 packets, these two bytes are the length field.

You can filter by protocol type by creating a protocol-type access list and then applying the access list to an interface.



Note

Type-code access lists can have an impact on system performance; therefore, keep the lists as short as possible and use wildcard bit masks whenever possible.

To create a protocol-type access list, use the following command in global configuration mode:

Command	Purpose
<code>access-list access-list-number {permit deny} type-code wild-mask</code>	Creates an access list to filter frames by protocol type.

To apply an access list to an interface, use the following command in interface configuration mode:

Command	Purpose
<code>lex input-type-list access-list-number</code>	Adds a filter for Ethernet- and SNAP-encapsulated packets on input.

For an example of creating an access list and applying it to a LAN Extender interface, see the “LAN Extender Interface Access List Examples” section.

Controlling Priority Queueing

Priority output queueing is an optimization mechanism that allows you to set priorities on the type of traffic passing through the network. Packets are classified according to various criteria, including protocol and subprotocol type. Packets are then queued on one of four output queues.

To control priority queueing on a LAN Extender interface, perform the following tasks:

- Set the priority by protocol type.
- Assign a priority group to an interface.

To establish queueing priorities based on the protocol type, use one of the following commands in global configuration mode:

Command	Purpose
<code>priority-list list protocol protocol</code> {high medium normal low}	Establishes queueing priorities based on the protocol type.
or <code>priority-list list protocol bridge {high medium normal low} list list-number</code>	

You then assign a priority list to an interface. You can assign only one list per interface. To assign a priority list to a LAN Extender interface, use the following command in interface configuration mode:

Command	Purpose
<code>lex priority-group group</code>	Assigns a priority list to a LAN Extender interface, which activates priority output queueing on the LAN Extender.

Controlling the Sending of Commands to the LAN Extender

Each time the core router sends a command to the LAN Extender, the LAN Extender responds with an acknowledgment. The core router waits for the acknowledgment for a predetermined amount of time. If it does not receive an acknowledgment in this time period, the core router sends the command again.

By default, the core router waits 2 seconds for an acknowledgment from the LAN Extender. You might want to change this interval if your connection to the LAN Extender requires a different amount time. To determine whether commands to the LAN Extender are timing out, use the **debug lex rcmd** privileged EXEC command. To change this interval, use the following command in interface configuration mode:

Command	Purpose
<code>lex timeout milliseconds</code>	Sets the amount of time that the core router waits to receive an acknowledgment from the LAN Extender.

By default, the core router sends each command ten times before giving up. The core router displays an error message when it gives up sending commands to the LAN Extender. To change this default, use the following command in interface configuration mode:

Command	Purpose
<code>lex retry-count number</code>	Sets the number of times the core router sends a command to the LAN Extender before giving up.

Shutting Down and Restarting the LAN Extender's Ethernet Interface

From the core router, you can shut down the LAN Extender's Ethernet interface. This stops traffic on the remote Ethernet LAN from reaching the core router, but leaves the LAN Extender interface that you created intact.



Note

There are no commands that allow you to shut down the serial interface on the LAN Extender.

To shut down the LAN Extender's Ethernet interface, use the following command in interface configuration mode:

Command	Purpose
<code>shutdown</code>	Shuts down the LAN Extender's Ethernet interface.

To restart the LAN Extender's Ethernet interface, use the following command in interface configuration mode:

Command	Purpose
<code>no shutdown</code>	Restarts the LAN Extender's Ethernet interface.

Restarting the LAN Extender

To reboot the LAN Extender and reload the software, use one of the following commands in privileged EXEC mode:

Command	Purpose
<code>clear controller lex <i>number</i> [prom]</code>	Halts operation of the LAN Extender and initiates a cold restart.
<code>clear controller lex <i>slot/port</i> [prom]</code>	Halts operation of the LAN Extender on a Cisco 7000 series routers.

Downloading a Software Image to the LAN Extender

When the LAN Extender is powered on, it runs the software image that is shipped with the unit. You can download a new software image from a TFTP server or from Flash memory on the core router to the LAN Extender.

To download a software image to the LAN Extender, use one of the following commands in privileged EXEC mode:

Command	Purpose
<code>copy tftp lex <i>number</i></code>	Downloads a software image from a TFTP server.
<code>copy flash lex <i>number</i></code>	Downloads a software image from Flash memory.

Troubleshooting the LAN Extender

The primary means of troubleshooting the LAN Extender is by using the light emitting diodes (LEDs) that are present on the chassis. This section will help you assist the remote user at the LAN Extender site who can observe the LEDs.

The key to problem solving is to try to isolate the problem to a specific subsystem. By comparing what the system is doing to what it should be doing, the task of isolating a problem is greatly simplified.

The Cisco 1000 series LAN Extender uses multiple LEDs to indicate its current operating condition. By observing the LEDs, any fault conditions that the unit is encountering can be observed. The system LEDs are located on the front panel of your LAN Extender (see Figure 9).

Figure 9 LAN Extender LEDs

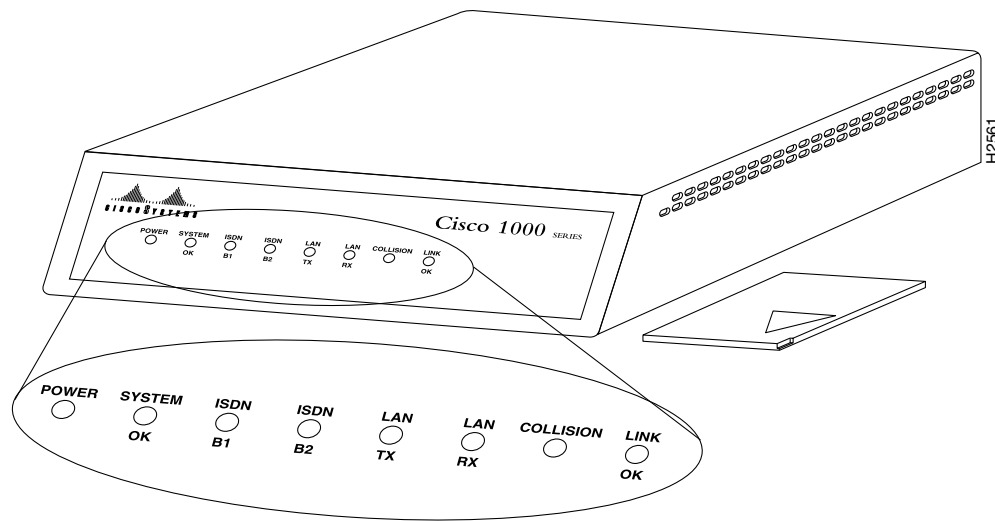

When there is a problem with the LAN Extender, a user at the remote site should contact you and report the condition of the LEDs located on the front panel of the LAN Extender. You can then use this information to diagnose or verify the operation of the system. Table 4 explains the LEDs.

Table 4 LED Trouble Indicators

LED	Condition	Meaning
POWER	On Steady	Indicates that 12 V DC is being supplied to the LAN Extender.
	Off	Indicates that power is not reaching the unit. To correct the problem, make sure the power supply is plugged into the wall receptacle and that the cable from the power supply is connected to the unit.

Table 4 LED Trouble Indicators (continued)

SYSTEM OK	On Steady	Lights when the unit passes the power on diagnostics. This indicates proper operation.
	Blinking	Blinks while running startup diagnostics, then goes on steady. Blinking after the start-up diagnostics indicates that a system error has been encountered. Contact your system administrator who will have you disconnect and then reconnect the power to recycle your LAN Extender. If the blinking continues, check your WAN connection and the RX and TX LEDs.
	Off	An error condition has occurred. Contact your system administrator who will ask you to disconnect the power cord and then reconnect it to re-establish power to your LAN Extender.
LED	Condition	Meaning
ISDN B1 and ISDN B2	Flicker	The serial line is transmitting and receiving packets normally.
	Blinking	A line fault has been detected. The LEDs will go on for several seconds and then they will blink a certain number of times to indicate a particular error. The LEDs will blink at a rate of one to two blinks per second. The following are the errors that can be encountered: 1 blink = The serial line is down. 2 blinks = No clock signal was received. 3 blinks = An excessive number of cyclic redundancy check (CRC) errors has been received. 4 blinks = The line is noisy. 5 blinks = A loopback condition has occurred. 6 blinks = The PPP link has failed. Contact your system administrator.
LAN TX and LAN RX	Flicker	The Ethernet LAN connection is transmitting and receiving data normally.
COLLISION		Detects data collisions.
LINK OK	Steady	Indicates that the serial link is up and functioning.

For more complete network troubleshooting information, refer to the *Troubleshooting Internetworking Systems* publication.

Configuring a Token Ring Interface

Cisco supports various Token Ring interfaces. Refer to the *Cisco Product Catalog* for information about platform and hardware compatibility.

The Token Ring interface supports both routing (Layer 3 switching) and source-route bridging (Layer 2 switching) on a per-protocol basis. For example, IP traffic could be routed while SNA traffic is bridged. Routing features enhance source-route bridges.

The Token Ring MIB variables support the specification in RFC 1231, “IEEE 802.5 Token Ring MIB.” The mandatory Interface Table and Statistics Table are implemented, but the optional Timer Table of the Token Ring MIB is not. The Token Ring MIB has been implemented for the Token Ring Interface Processor (TRIP).

Use the **show interfaces**, **show controllers token**, and **show controllers cbus EXEC** commands to display the Token Ring numbers. These commands provide a report for each ring that Cisco IOS software supports.

**Note**

If the system receives an indication of a cabling problem from a Token Ring interface, it puts that interface into a reset state and does not attempt to restart it. It functions this way because periodic attempts to restart the Token Ring interface drastically affect the stability of routing tables. Once you have again plugged the cable into the MAU, restart the interface by using the **clear interface tokenring** command, where the *number* argument is the interface number.

By default, the Token Ring interface uses the SNAP encapsulation format defined in RFC 1042. It is not necessary to define an encapsulation method for this interface.

Particle-Based Switching of Source-Route Bridge Packets on Cisco 7200 Series Routers

Particle-based switching is supported for SRB packets (over FDDI and Token Ring) by default.

Particle-based switching adds scatter-gather capability to SRB to improve performance. Particles represent a communications data packet as a collection of noncontiguous buffers. The traditional Cisco IOS packet has a packet type control structure and a single contiguous data buffer. A particle packet has the same packet type control structure, but it also maintains a queue of particle type structures, each of which manages its own block.

The scatter-gather architecture used by particle-based switching provides the following advantages:

- Allows drivers to use memory more efficiently (especially when using media that has a large maximum transmission unit [MTU]). For example, Token Ring buffers could be 512 bytes rather than 16 KB.
- Allows concurrent use of the same region of memory. For example, on IP multicast a single packet is received and sent out on multiple interfaces simultaneously.
- Allows insertion or deletion of memory at any location in a packet (not just at the beginning or end).

For information about configuring SRB over FDDI, refer to the “Configuring Source-Route Bridging” chapter of the *Cisco IOS Bridging and IBM Networking Configuration Guide*.

Dedicated Token Ring Port Adapter

The Dedicated Token Ring port adapter (PA-4R-DTR) is available on Cisco 7500 series routers, Cisco 7200 series routers, and Cisco 7000 series routers with the 7000 Series Route Switch Processor (RSP7000) and 7000 Series Chassis Interface (RSP7000CI).

The PA-4R-DTR provides up to four IBM Token Ring or IEEE 802.5 Token Ring interfaces. Each Token Ring interface can be set for 4 Mbps or 16 Mbps half-duplex or full-duplex operation and can operate as a standard Token Ring station or as a concentrator port. The default for all interfaces is Token Ring station mode with half-duplex 16-Mbps operation. The PA-4R-DTR connects over Type 1 lobe or Type 3 lobe cables, with each interface providing an RJ-45 receptacle.

Token Ring Interface Configuration Task List

Perform the tasks in the following sections to configure a Token Ring interface:

- Specifying a Token Ring Interface (Required)
- Enabling Early Token Release (Optional)
- Configuring PCbus Token Ring Interface Management (Optional)
- Enabling Token Ring Concentrator Port (Optional)
- Monitoring and Maintaining the Port (Optional)

Specifying a Token Ring Interface

To specify a Token Ring interface and enter interface configuration mode, use one of the following commands in global configuration mode:

Command	Purpose
<code>interface tokenring number</code>	Begins interface configuration.
<code>interface tokenring slot/port</code>	Begins interface configuration for the Cisco 7200 or Cisco 7500 series routers.
<code>interface tokenring slot/port-adapter/port</code>	Begins interface configuration for the Cisco 7500 series routers.

Enabling Early Token Release

Cisco Token Ring interfaces support early token release, a method whereby the interface releases the token back onto the ring immediately after transmitting rather than waiting for the frame to return. This feature can help to increase the total bandwidth of the Token Ring. To configure the interface for early token release, use the following command in interface configuration mode:

Command	Purpose
<code>early-token-release</code>	Enables early token release.

Configuring PCbus Token Ring Interface Management

The Token Ring interface on the AccessPro PC card can be managed by a remote LAN manager over the PCbus interface. Currently, the LanOptics Hub Networking Management software running on an IBM-compatible PC is supported.

To enable LanOptics Hub Networking Management of a PCbus Token Ring interface, use the following command in interface configuration mode:

Command	Purpose
<code>local-lnm</code>	Enables PCbus LAN management.

Enabling Token Ring Concentrator Port

To enable an interface to operate as a concentrator port, use the following command in interface configuration mode:

Command	Purpose
<code>port</code>	Specifies concentrator port operation.

Monitoring and Maintaining the Port

To monitor the Token Ring Concentrator Port, use one or more of the following commands in EXEC mode:

Command	Purpose
<code>show controllers token</code>	Displays internal state information about the Token Ring interfaces in the system.
<code>show interface token</code>	Displays high-level statistics for a particular interface.

LAN Interface Configuration Examples

This section provides examples to illustrate configuration tasks described in this chapter. The following examples are included:

- Ethernet Encapsulation Enablement Example
- Full Duplex Enablement Operation Example
- PA-12E/2FE Port Configuration Examples
- PA-VG100 Port Adapter Configuration Example
- Fast EtherChannel Configuration Examples
- FDDI Frames Configuration Example
- Hub Configuration Examples
- LAN Extender Enablement Interface Example
- LAN Extender Interface Access List Examples

Ethernet Encapsulation Enablement Example

These commands enable standard Ethernet Version 2.0 encapsulation on the Ethernet interface processor in slot 4 on port 2 of a Cisco 7500 series routers:

```
interface ethernet 4/2
 encapsulation arpa
```

Full Duplex Enablement Operation Example

The following example assigns an IP address and subnet mask, specifies an MII Ethernet connector, and enables full-duplex mode on Fast Ethernet interface port 0 in slot 1 port adapter 0:

```
Router(config)# interface fastethernet 1/0/0
Router(config-if)# ip address 1.1.1.10 255.255.255.0
Router(config-if)# full-duplex
Router(config-if)# media-type mii
Router(config-if)# exit
Router(config)# exit
```

PA-12E/2FE Port Configuration Examples

The following is an example of a configuration for the PA-12E/2FE port adapter interface. Bridge groups 10, 20, and 30 use IEEE Spanning-Tree Protocol. The first four interfaces of a PA-12E/2EF port adapter in port adapter slot 3 use bridge groups 10 and 20. Each interface is assigned to a bridge group and the shutdown state is set to up. The PA-12E/2FE port adapter supports store-and-forward or cut-through switching technology between interfaces within the same bridge group; store-and-forward is the default. In the following example, the **cut-through** command is used to configure each interface for cut-through switching of received and transmitted data:

```
Router# configure terminal
Enter configuration commands, one per line. End with CNTL-Z.
Router(config)# bridge 10 protocol ieee
Router(config)# bridge 20 protocol ieee
Router(config)# bridge 30 protocol ieee

Router(config)# interface fastethernet 3/0
Router(config-if)# bridge-group 10
Router(config-if)# cut-through
Router(config-if)# no shutdown
Router(config-if)# exit
Router(config)#
%LINEPROTO-5-UPDOWN: Line protocol on Interface Fast Ethernet3/0, changed
state to up
%LINK-3-UPDOWN: Interface Fast Ethernet3/0, changed state to up

Router(config)# interface fastethernet 3/1
Router(config-if)# bridge-group 10
Router(config-if)# cut-through
Router(config-if)# no shutdown
Router(config-if)# exit
Router(config)#
%LINEPROTO-5-UPDOWN: Line protocol on Interface Fast Ethernet3/1, changed
state to up
%LINK-3-UPDOWN: Interface Fast Ethernet3/1, changed state to up
```

```

Router(config)# interface ethernet 3/2
Router(config-if)# bridge-group 20
Router(config-if)# cut-through
Router(config-if)# no shutdown
Router(config-if)# exit
Router(config)#
%LINEPROTO-5-UPDOWN: Line protocol on Interface Ethernet3/2, changed state to up
%LINK-3-UPDOWN: Interface Ethernet3/2, changed state to up

Router(config)# interface ethernet 3/3
Router(config-if)# bridge-group 20
Router(config-if)# cut-through
Router(config-if)# no shutdown
Router(config-if)# exit
Router(config)#
%LINEPROTO-5-UPDOWN: Line protocol on Interface Ethernet3/3, changed state to up
%LINK-3-UPDOWN: Interface Ethernet3/3, changed state to up

```

The following example shows integrated routing and bridging enabled on the bridge groups. Bridge group 10 is assigned an IP address and subnet mask and the shutdown state is changed to up. Bridge group 10 is configured to route IP.

```

Router(config)# bridge irb
Router(config)# interface bvi 10
Router(config-if)# ip address 1.1.15.1 255.255.255.0
Router(config-if)# no shutdown
Router(config-if)# exit
Router(config)#
%LINEPROTO-5-UPDOWN: Line protocol on Interface BVI10, changed state to up

Router(config)# bridge 10 route ip
Router(config)# exit
Router#

```

PA-VG100 Port Adapter Configuration Example

The following is an example of a basic configuration for the PA-VG100 port adapter interface in slot 1 on a Cisco 7500 series router. In this example, IP routing is enabled on the router, so an IP address and subnet mask are assigned to the interface.

```

configure terminal
interface vg-anylan 1/0/0
ip address 1.1.1.10 255.255.255.0
no shutdown
exit
exit

```

Fast EtherChannel Configuration Examples

Figure 10 shows four point-to-point Fast Ethernet interfaces that are aggregated into a single Fast EtherChannel interface.

Figure 10 Fast Ethernet Interfaces Aggregated into a Fast EtherChannel

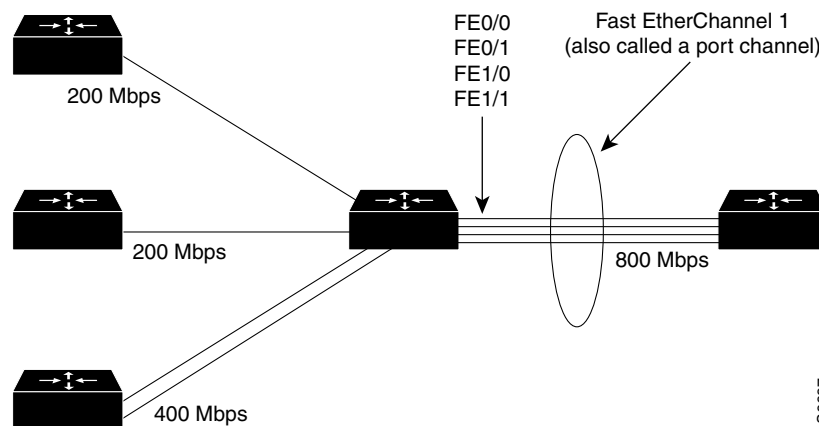

The following is an example of how to create a Fast EtherChannel (port-channel interface) with four Fast Ethernet interfaces. In this example, ISL is enabled on the Fast EtherChannel and an IP address is assigned to the subinterface.

```
Router# configure terminal
Router(config)# interface port-channel 1
Router(config-if)# no shutdown
Router(config-if)# exit
Router(config)# interface port-channel 1.1
Router(config-if)# ip address 1.1.1.10 255.255.255.0
Router(config-if)# encapsulation isl 100
Router(config-if)# exit
Router(config)# interface fastethernet 0/0/0
Router(config-if)# no ip address
Router(config-if)# channel-group 1
Fast Ethernet 0/0 added as member-1 to port-channel1.
Router(config-if)# exit
Router(config)# interface fastethernet 0/1/0
Router(config-if)# no ip address
Router(config-if)# channel-group 1
Fast Ethernet 0/1 added as member-2 to port-channel1.
Router(config-if)# exit
Router(config)# interface fastethernet 1/0/0
Router(config-if)# no ip address
Router(config-if)# channel-group 1
Fast Ethernet 1/0 added as member-3 to port-channel1.
Router(config-if)# exit
Router(config)# interface fastethernet 1/1/0
Router(config-if)# no ip address
Router(config-if)# channel-group 1
Fast Ethernet 1/1 added as member-4 to port-channel1.
Router(config-if)# exit
Router(config)# exit
Router#
```

The following is a partial example of a configuration file. The MAC address is automatically added to the Fast Ethernet interface when the interfaces are added to the Fast EtherChannel.

**Note**

If you do not assign a static MAC address on the port-channel interface, the Cisco IOS software automatically assigns a MAC address. If you assign a static MAC address and then later remove it, the Cisco IOS software automatically assigns a MAC address.

```
interface Port-channel1
 ip address 1.1.1.10 255.255.255.0
!
interface Port-channel1.1
 encapsulation isl 100
!
interface Fast Ethernet0/0/0
 mac-address 00e0.1476.7600
 no ip address
 channel-group 1
!
interface Fast Ethernet0/1/0
 mac-address 00e0.1476.7600
 no ip address
 channel-group 1
!
interface Fast Ethernet1/0/0
 mac-address 00e0.1476.7600
 no ip address
 channel-group 1
!
interface Fast Ethernet1/1/0
 mac-address 00e0.1476.7600
 no ip address
 channel-group 1
```

FDDI Frames Configuration Example

The following example shows how to configure the FDDI interface to transmit four frames per token capture:

```
! Enter global configuration mode.
4700# configure terminal
! Enter interface configuration mode.
4700(config)# interface fddi0
! Show the fddi command options.
4700(config-if)# fddi ?
encapsulate          Enable FDDI Encapsulation bridging
frames-per-token     Maximum frames to transmit per service opportunity
tl-min-time          Line state transmission time
token-rotation-time Set the token rotation timer
valid-transmission-time Set transmission valid timer
! Show fddi frames-per-token command options.
4700(config-if)# fddi frames-per-token ?
<1-10> Number of frames per token, default = 3
! Specify 4 as the maximum number of frames to be transmitted per token.
4700(config-if)# fddi frames-per-token 4
```

Hub Configuration Examples

The following sections provide examples of hub configuration:

- Hub Port Startup Examples
- Source Address for an Ethernet Hub Port Configuration Examples
- Hub Port Shutdown Examples
- SNMP Illegal Address Trap Enablement for Hub Port Example

Hub Port Startup Examples

The following example configures port 1 on hub 0 of Ethernet interface 0:

```
hub ethernet 0 1
no shutdown
```

The following example configures ports 1 through 8 on hub 0 of Ethernet interface 0:

```
hub ethernet 0 1 8
no shutdown
```

Source Address for an Ethernet Hub Port Configuration Examples

The following example configures the hub to allow only packets from MAC address 1111.2222.3333 on port 2 of hub 0:

```
hub ethernet 0 2
source-address 1111.2222.3333
```

The following example configures the hub to remember the first MAC address received on port 2, and allow only packets from that learned MAC address:

```
hub ethernet 0 2
source-address
```

Hub Port Shutdown Examples

The following example shuts down ports 3 through 5 on hub 0:

```
hub ethernet 0 3 5
shutdown
```

The following example shuts down port 3 on hub 0:

```
hub ethernet 0 3
shutdown
```

SNMP Illegal Address Trap Enablement for Hub Port Example

The following example specifies the gateway IP address and enables an SNMP trap to be issued to the host 172.69.40.51 when a MAC address violation is detected on hub ports 2, 3, or 4. It specifies that interface Ethernet 0 is the source for all traps on the router. The community string is defined as the string *public* and the read/write parameter is set.

```
ip route 0.0.0.0 0.0.0.0 172.22.10.1
snmp-server community public rw
snmp-server trap-source ethernet 0
snmp-server host 172.69.40.51 public
hub ethernet 0 2 4
snmp trap illegal-address
```

LAN Extender Enablement Interface Example

The following simple example configures and creates a LAN Extender interface. In this example, the MAC address of the LAN Extender is 0000.0c00.0001.

```
interface serial 4
 encapsulation ppp
interface lex 0
 lex burned-in-address 0000.0c00.0001
 ip address 131.108.172.21 255.255.255.0
```

LAN Extender Interface Access List Examples

This section provides these examples of LAN extender interface configuration:

- MAC Address Filtering Example
- Ethernet Type Code Filtering Example

MAC Address Filtering Example

The following is an example that controls which traffic from Macintosh computers on the remote Ethernet LAN reaches the core router:

```
access-list 710 permit 0800.0298.0000 0000.0000.FFFF
access-list 710 deny 0800.0276.2917 0000.0000.0000
access-list 710 permit 0800.0000.0000 0000.FFFF.FFFF
interface lex 0
 lex input-address-list 710
```

The first line of this access list permits traffic from any Macintosh whose MAC address starts with 0800.0298. The remaining two octets in the MAC address can be any value because the mask for these octets is FFFF (“don’t care” bits).

The second line specifically rejects all traffic originating from a Macintosh with the MAC address of 0800.0276.2917. Note that none of the mask bits are “don’t care” bits.

The third line specifically permits all traffic from other Macintoshes whose MAC addresses start with 0800. Note that in the mask, the “don’t care” bits are the rest of the address.

At the end of the list is an implicit “deny everything” entry, meaning that any address that does not match an address or address group on the list is rejected.

Ethernet Type Code Filtering Example

Using the same configuration as in the previous section, you could allow only the Macintosh traffic by Ethernet type code with the following access list:

```
access-list 220 permit 0x809B 0x0000
interface lex 0
  lex input-type-list 220
```

This access list permits only those messages whose protocol number matches the masked protocol number in the first line. The implicit last entry in the list is a “deny everything” entry.

