



Configuring Token Ring Inter-Switch Link

This chapter explains how to configure Token Ring Inter-Switch Link (TRISL) on Cisco routers. The chapter describes TRISL in the context of the Inter-Switch Link (ISL) protocol and the Token Ring VLAN concept.

For a complete description of the Token Ring Inter-Switch Link commands in this chapter, refer to the “Token Ring Inter-Switch Link Commands” chapter in the *Cisco IOS Bridging and IBM Networking Command Reference, Volume I*. To locate documentation of other commands that appear in this chapter, use the command reference master index or search online. For information on how Token Ring VLANs are implemented on switches, refer to the *Catalyst Token Ring Switching Implementation Guide*, the *Catalyst 5000 Series Token Ring Configuration Notes*, the *Catalyst 3900 Token Ring Switching User Guide*, and the *Catalyst 3920 Token Ring Switching User Guide*.

This chapter contains the following sections:

- Technology Overview, page 147
- TRISL Configuration Tasks, page 150
- Monitoring TRISL Statistics, page 155
- TRISL Configuration Examples, page 156

Technology Overview

Cisco’s TRISL Implementation

This section contains information related to Cisco’s implementation of TRISL that you should understand before you proceed to the “TRISL Configuration Tasks” section.

ISL and TRISL

ISL is a layer 2 protocol that enables switches and routers to transport Ethernet frames from multiple VLANs across Fast Ethernet or Gigabit Ethernet links. Cisco’s TRISL protocol extends the ISL model to include the transport of Token Ring frames from multiple VLANs across these same links.

TRISL support on Cisco routers provides inter-VLAN routing and bridging across a 100-Mb Fast Ethernet link. ISL and TRISL together provide routing and bridging between Token Ring and Ethernet LANs, ELANS, and VLANs.

TRISL is supported on the following platforms with any one of the following port adapters:

- Cisco 7500 or Cisco 7200 series routers
 - Two-port Fast Ethernet/ISL 100BaseTX
 - Two-port Fast Ethernet/ISL 100BaseFX
 - One-port Fast Ethernet 100BaseTX
 - One-port Fast Ethernet 100BaseFX
- Cisco 4500 or 4700 series routers
 - NM-1FE
- Cisco 3600 or 2600 series routers
 - NM-1FE1CE1
 - NM-1FE1CT1
 - NM-1FE1R2W
 - NM-1FE2CE1
 - NM-1FE2CT1
 - NM-1FE2W
 - NM-2FE2W



Note

The two-port Fast Ethernet/ISL port adapters support frame sizes up to 17800 bytes and the one-port Fast Ethernet port adapters support a frame size of up to 1500 bytes.

TRISL provides the following capabilities and features, which will be described in the “TRISL Configuration Tasks” and “TRISL Configuration Examples” sections later in the chapter:

- IP routing for source routed and non-source-routed frames between TRISL VLANs and any LAN, ELAN, or VLAN.
- IPX routing for source routed and non-source-routed frames between TRISL VLANs and any LANs, ELANs, or VLANs.
- Source-Route Bridging (SRB) between TRISL VLANs and SRB-capable LANs, ELANs, or VLANs.
- Source-Route Transparent Bridging (SRT) between TRISL VLANs and SRT-capable LANs, ELANs, or VLANs.
- Source-Route Translational Bridging (SR/TLB) between TRISL VLANs and Ethernet LANs, ELANs, or VLANs.
- Duplicate Ring Protocol (DRiP), which prevents external loops that could result if the router’s virtual ring number were duplicated elsewhere in the network.



Note

VLAN Trunk Protocol (VTP) is currently not supported for TRISL on the routers.

Token Ring VLANs

A VLAN is essentially a broadcast domain. In transparent bridging, there is only one type of broadcast frame and, therefore, only one level of broadcast domain and one level of VLAN. In source routing, however, there are two types of broadcast frames:

- Those that are confined to a single ring
- Those that traverse the bridged domain

Therefore, there are two levels of VLANs in a Token Ring switched network.

The first level is the Token Ring Concentrator Relay Function (TrCRF). At this level, the VLAN is a logical ring and, as such, is assigned a ring number. On a Token Ring switch, the logical ring (TrCRF) contains one or more physical ports. On a router, the logical ring (TrCRF) does not contain any physical ports, but rather is used only in processing source-routed traffic to terminate the routing information field (RIF).

The second level is the Token Ring Bridge Relay Function (TrBRF). This is the parent VLAN to which TrCRF VLANs are assigned. At this level, the VLAN is a logical bridge and, as such, is assigned a bridge number. The logical bridge (TrBRF) contains the virtual ports that establish a connection between the TrBRF and its TrCRFs. The TrBRF can be extended across a network of switches and routers via ISL, as shown in Figure 52.

Figure 52 Physical View of Switches Interconnected via ISL

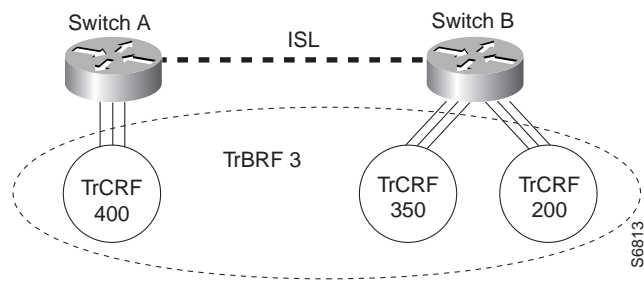

When you extend the TrBRF across an ISL link, you are essentially extending the bridge across devices, as shown in Figure 53.

Figure 53 Logical View of Switches Interconnected via ISL

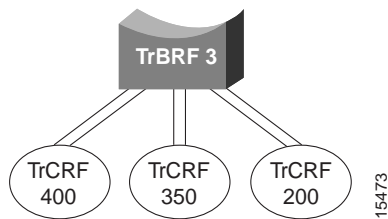

Therefore, if you use source-route bridging between the TrCRFs that belong to the TrBRF, only one hop appears in the RIF.

Traffic is switched between the ports in a TrCRF and bridged via SRB or SRT between the TrCRFs in a TrBRF.

Figure 54 illustrates a TrBRF that contains TrCRFs on both a router and a switch.

Figure 54 TrCRFs in a TrBRF

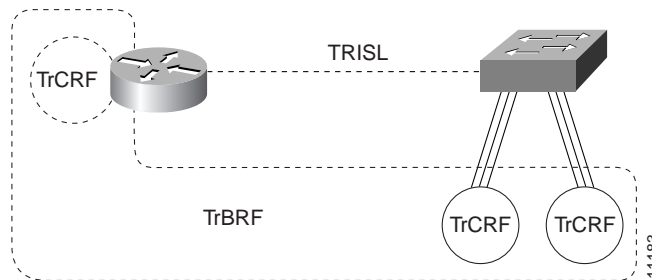

TRISL Configuration Tasks

To configure and monitor TRISL in your network, perform one or more of the following tasks:

- Configuring IP Routing over TRISL, page 150
- Configuring Hot Standby Router Protocol over TRISL, page 151
- Configuring IPX Routing over TRISL, page 152
- Configuring Source-Route Bridging over TRISL, page 153
- Configuring Source-Route Transparent Bridging over TRISL, page 153
- Configuring Source-Route Translational Bridging over TRISL, page 154

Configuring IP Routing over TRISL

The IP routing over TRISL VLANs feature extends IP routing capabilities to include support for routing IP frame types in VLAN configurations. To configure IP routing over TRISL, use the following commands, beginning in global configuration mode:

	Command	Purpose
Step 1	<code>ip routing</code>	Enables IP routing on the router.
Step 2	<code>interface type slot/port.subinterface-number</code>	Specifies the subinterface on which TRISL will be used.
Step 3	<code>encapsulation tr-isl trbrf-vlan vlanid bridge-num bridge-number</code>	Defines the encapsulation format, and specifies the VLAN identifier.
Step 4	<code>ip address ip-address mask</code>	Sets a primary IP address for an interface.

You can configure TRISL to route source-routed traffic by enabling the collection and use of RIF information on a TRISL subinterface. This creates a “pseudo-ring” to terminate the RIF path on a ring. Without RIF information, a packet could not be bridged across a source-route bridged network connected to this interface.

To route source-routed traffic, use the following additional commands in interface configuration mode:

	Command	Purpose
Step 1	<code>multiring trcrf-vlan <i>vlanid</i> ring <i>ring-number</i></code>	Creates a pseudo-ring to terminate the RIF and assigns it to a VLAN.
Step 2	<code>multiring {<i>protocol-keyword</i> [all-routes spanning all other]}</code>	Enables collection and use of RIF information with routed protocols.

**Note**

TRISL encapsulation must be specified for a subinterface before an IP address can be assigned to that subinterface.

Configuring Hot Standby Router Protocol over TRISL

The Hot Standby Router Protocol (HSRP) provides fault tolerance and enhanced routing performance for IP networks. HSRP allows Cisco routers to monitor each other’s operational status and very quickly assume packet forwarding responsibility in the event the current forwarding device in the HSRP group fails or is taken down for maintenance. The standby mechanism remains transparent to the attached hosts and can be deployed on any LAN type. With multiple hot-standby groups, routers can simultaneously provide redundant backup and perform load-sharing across different IP subsets.

To configure HSRP over TRISL between VLANs, use the following commands in interface configuration mode:

	Command	Purpose
Step 1	<code>interface <i>type slot/port subinterface-number</i></code>	Specifies the subinterface on which ISL will be used.
Step 2	<code>encapsulation tr-isl trbrf-vlan <i>vlanid bridge-num bridge-number</i></code>	Defines the encapsulation format, and specify the VLAN identifier.
Step 3	<code>ip address <i>ip-address mask [secondary]</i></code>	Specifies the IP address for the subnet on which ISL will be used.
Step 4	<code>standby [<i>group-number</i>] ip [<i>ip-address [secondary]</i>]</code>	Enables HSRP.

To customize hot standby group attributes, use one or more of the following commands in interface configuration mode:

Command	Purpose
<code>standby [<i>group-number</i>] timers <i>hellotime holdtime</i></code>	Configures the time between hello packets and the hold time before other routers declare the active router to be down.
<code>standby [<i>group-number</i>] priority <i>priority</i></code>	Sets the hot standby priority used to choose the active router.

Command	Purpose
<code>standby [group-number] preempt</code>	Specifies that if the local router has priority over the current active router, the local router should attempt to take its place as the active router.
<code>standby [group-number] track type-number [interface-priority]</code>	Configures the interface to track other interfaces, so that if one of the other interfaces goes down, the hot standby priority for the device is lowered.
<code>standby [group-number] authentication string</code>	Enables the automatic spanning-tree function on a group of bridged interfaces.

Configuring IPX Routing over TRISL

The IPX Routing over ISL VLANs feature extends Novell NetWare routing capabilities to include support for routing all standard IPX encapsulations for Token Ring frame types in VLAN configurations. Users with Novell NetWare environments can configure either SAP or SNAP encapsulations to be routed using the TRISL encapsulation across VLAN boundaries.

Netware users can now configure consolidated VLAN routing over a single VLAN trunking interface. With configurable Token Ring encapsulation protocols on a per VLAN basis, users have the flexibility of using VLANs regardless of their NetWare Token Ring encapsulation. Encapsulation types and corresponding framing types are described in the “Configuring Novell IPX” chapter of the *Cisco IOS AppleTalk and Novell IPX Configuration Guide*.



Note

Only one type of IPX encapsulation can be configured per VLAN (subinterface). The IPX encapsulation used must be the same within any particular subnet. A single encapsulation must be used by all NetWare systems that belong to the same LAN.

To configure Cisco IOS software to route IPX on a router with connected VLANs, use the following commands, beginning in global configuration mode:

	Command	Purpose
Step 1	<code>ipx routing [node]</code>	Enables IPX routing globally.
Step 2	<code>interface type slot/port.subinterface-number</code>	Specifies the subinterface on which TRISL will be used.
Step 3	<code>encapsulation tr-is1 trbrf-vlan vlanid bridge-num bridge-number</code>	Defines the encapsulation for TRISL.
Step 4	<code>ipx encapsulation encapsulation type</code>	Specifies the IPX encapsulation.
Step 5	<code>ipx network network number</code>	Specifies the IPX network.

**Note**

The default IPX encapsulation format for Token Ring in Cisco IOS routers is SAP. Therefore, you only need to explicitly configure the IPX encapsulation type if your Token Ring network requires SNAP encapsulation instead of SAP.

When routing source-routed traffic for specific VLANs, use the following additional commands in interface configuration mode:

	Command	Purpose
Step 1	<code>multiring trcrf-vlan vlanid trcrf-ring ring-number</code>	Creates a pseudo-ring to terminate the RIF and assign it to a VLAN.
Step 2	<code>multiring {protocol-keyword [all-routes spanning all other]}</code>	Enables collection and use of RIF information with routed protocols.

Configuring Source-Route Bridging over TRISL

To configure SRB over TRISL, use the following commands beginning in global configuration mode:

	Command	Purpose
Step 1	<code>source-bridge ring-group vring-num</code>	Configures a virtual ring for the router.
Step 2	<code>interface type slot/port.subinterface-number</code>	Specifies the subinterface on which TRISL will be used.
Step 3	<code>encapsulation tr-isl trbrf-vlan vlanid bridge-num bridge-number</code>	Defines the encapsulation for TRISL.
Step 4	<code>source-bridge trcrf-vlan vlanid ring-group ring-number</code>	Attaches a TrCRF VLAN identifier to the router's virtual ring.

Configuring Source-Route Transparent Bridging over TRISL

To configure transparent bridging over TRISL, use the following command beginning in global configuration mode:

	Command	Purpose
Step 1	<code>interface type slot/port.subinterface-number</code>	Specifies the subinterface on which TRISL will be used.
Step 2	<code>encapsulation tr-isl trbrf-vlan vlanid bridge-num bridge-number</code>	Defines the encapsulation for TRISL.
Step 3	<code>bridge-group bridge-group number</code>	Specifies the bridge group to which the TRISL subinterface belongs.

Configuring Source-Route Translational Bridging over TRISL

To configure source-route translational bridging over TRISL, use the following commands beginning in global configuration mode:

	Command	Purpose
Step 1	<code>source-bridge ring-group vring-num</code>	Configures a virtual ring for the router.
Step 2	<code>source-bridge transparent ring-group pseudo-ring bridge-number tb-group [oui]</code>	Enables bridging between transparent bridging and source-route bridging.
Step 3	<code>interface type slot/port.subinterface-number</code>	Specifies the subinterface on which TRISL will be used.
Step 4	<code>encapsulation tr-isl trbrf-vlan vlanid bridge-num bridge-number</code>	Defines the encapsulation for TRISL.
Step 5	<code>source-bridge trcrf-vlan vlanid ring-group ring-number</code>	Assigns a VLAN ID to the router's virtual ring.



Note For a complete description of SR/TLB, including configuring translation compatibility with IBM 8209 bridges and configuring Token Ring LLC2 to Ethernet Type II (0x80d5) and Token Ring LLC2 to Ethernet 802.3 LLC2 (standard) translations, please refer to the “Configuring Source-Route Bridging” chapter in this publication and “Source-Route Bridging Commands” chapter in the *Cisco IOS Bridging and IBM Command Reference, Volume 1*.

Configuring Automatic Spanning Tree

The automatic spanning-tree function supports automatic resolution of spanning trees in SRB networks, which provides a single path for spanning explorer frames to traverse from a given node in the network to another. Spanning explorer frames have a single-route broadcast indicator set in the routing information field. Port identifiers consist of ring numbers and bridge numbers associated with the ports. The spanning-tree algorithm for SRB does not support Topology Change Notification Bridge Protocol Data Unit (BPDU).

Although the automatic spanning-tree function can be configured with Source-Route Translational Bridging (SR/TLB), the SRB domain and transparent bridging domain have separate spanning trees. Each Token Ring interface can belong to only one spanning tree. Only one bridge group can run the automatic spanning-tree function at a time.

To create a bridge group that runs an automatic spanning-tree function compatible with the IBM SRB spanning-tree implementation, use the following command in global configuration mode:

Command	Purpose
<code>bridge bridge-group protocol ibm</code>	Creates a bridge group that runs the automatic spanning-tree function.

To enable the automatic spanning-tree function for a specified group of bridged interfaces in SRB or SR/TLB, use the following command in interface configuration mode:

Command	Purpose
<code>source-bridge spanning bridge-group</code>	Enables the automatic spanning-tree function on a group of bridged interfaces.

Monitoring TRISL Statistics

You can collect, clear, and display statistical information about the network.

The Duplicate Ring Protocol (DRiP) runs on Cisco routers and switches that support switched VLAN networking and is used to identify active Token Ring VLANs (TrCRFs).

DRiP maintains the status of TrCRFs and uses this information to determine whether there are multiple TrCRFs active in a TrBRF.

DRiP information is used for the following:

- All-routes explorer filtering

DRiP information is used in conjunction with the local configuration to determine which of the TrCRFs configured within a TrBRF have active ports. This information is used on the base switch to correctly filter all-routes explorers and on the ISL module to discard AREs that have already been on an attached ring.

- Detecting the configuration of duplicate TrCRFs across routers and switches, which would cause a TrCRF to be distributed across ISL trunks

DRiP information is used in conjunction with the local configuration information to determine which TrCRFs are already active on the switches. If a TrCRF is enabled on more than one switch or router, the ports associated with the TrCRF are disabled on all switches. A router will not disable the internal ring used for SRB and for routing source-routed traffic. Instead, the router generates the following error message to indicate that two identical TrCRFs exist:

```
DRIP conflict with CRF <vlan-id>
```

To show or clear DRiP or VLAN statistics, use one or all the following command in privileged EXEC mode:

Command	Purpose
<code>clear drip counters</code>	Clears DRiP counters.
<code>clear vlan statistics</code>	Removes VLAN statistics from any statically configured or system configured entries.
<code>show drip</code>	Displays DRiP information.
<code>show vlans</code>	Displays a summary of VLAN subinterfaces.



Note

When DRiP counters are cleared, the counter is reset to 0. Incrementing of DRiP counters indicates that the router is receiving packets across the TrBRF.

TRISL Configuration Examples

The following sections provide TRISL configuration examples:

- IP Routing Non-Source-Routed Frames between a TRISL VLAN and a Token Ring Interface Example, page 157
- IP Routing Source-Routed Frames between a TRISL VLAN and a Token Ring Interface Example, page 158
- IP Routing Source-Route Frames between a TRISL VLAN and an Ethernet ISL VLAN Example, page 159
- IP Routing Source-Routed Frames between TRISL VLANs Example, page 160
- IPX Routing Non-Source-Routed Frames between a TRISL VLAN and a Token Ring Interface Example, page 161
- IPX Routing Source-Routed Frames between a TRISL VLAN and a Token Ring Interface Example, page 162
- IPX Routing Source-Route Frames between a TRISL VLAN and an Ethernet ISL VLAN Example, page 163
- IPX Routing Source-Routed Frames between TRISL VLANs Example, page 164
- SRB between Token Ring and TRISL VLAN Example, page 165
- SRB between TRISL VLANs Example, page 166
- Transparent Bridging between Token Ring and TRISL VLAN Example, page 167
- SR/TLB between a TRISL VLAN and an Ethernet Interface Example, page 168
- SR/TLB between a TRISL VLAN and an Ethernet ISL VLAN Example, page 169
- TRISL with Fast EtherChannel, page 170

**Note**

Because the VLAN Trunk Protocol (VTP) is not supported on the router configured with TRISL, the TrCRF configuration on the router must also be specified in the Catalyst 5000 switch configuration.

IP Routing Non-Source-Routed Frames between a TRISL VLAN and a Token Ring Interface Example

Figure 55 illustrates IP routing between a TRISL VLAN and a Token Ring interface.

Figure 55 IP Routing between a TRISL VLAN and a Token Ring Interface

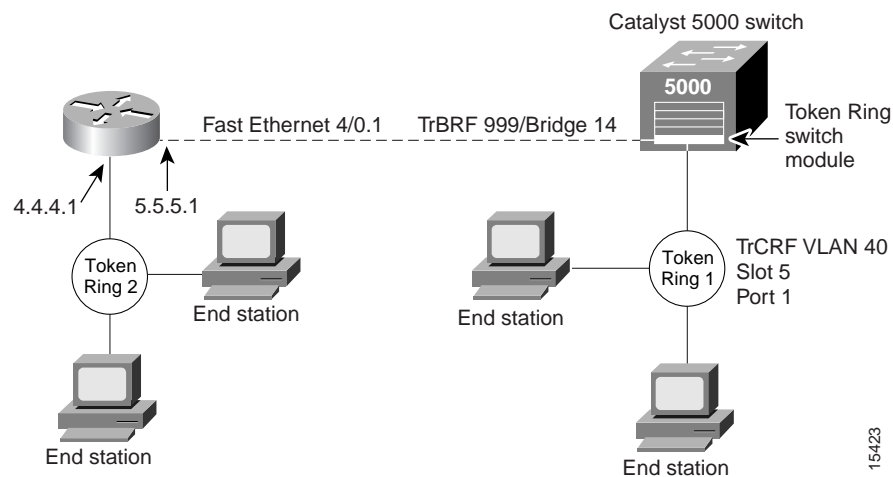

The following is the configuration for the router:

```
ip routing
interface TokenRing 3/1
 ip address 4.4.4.1 255.255.255.0
!
interface FastEthernet4/0.1
 ip address 5.5.5.1 255.255.255.0
 encapsulation tr-isl trbrf 999 bridge-num 14
```

The following is the configuration for the Catalyst 5000 switch with the Token Ring switch module in slot 5. In this configuration, the Token Ring port 1 is assigned to the TrCRF VLAN 40.

```
#vtp
set vtp domain trisl
set vtp mode server
set vtp v2 enable
#drip
set tokenring reduction enable
set tokenring distrib-crf disable
#vlans
set vlan 999 name trbrf type trbrf bridge 0xe stp ieee
set vlan 40 name trcrf40 type trcrf parent 999 ring 0x1 mode srt
#add token port to trcrf 40
set vlan 40 5/1
set trunk 1/2 on
```

IP Routing Source-Routed Frames between a TRISL VLAN and a Token Ring Interface Example

Figure 56 illustrates IP routing source-routed frames between a TRISL VLAN and a Token Ring interface.

Figure 56 Routing Source-Routed Frames between a TRISL VLAN and a Token Ring Interface

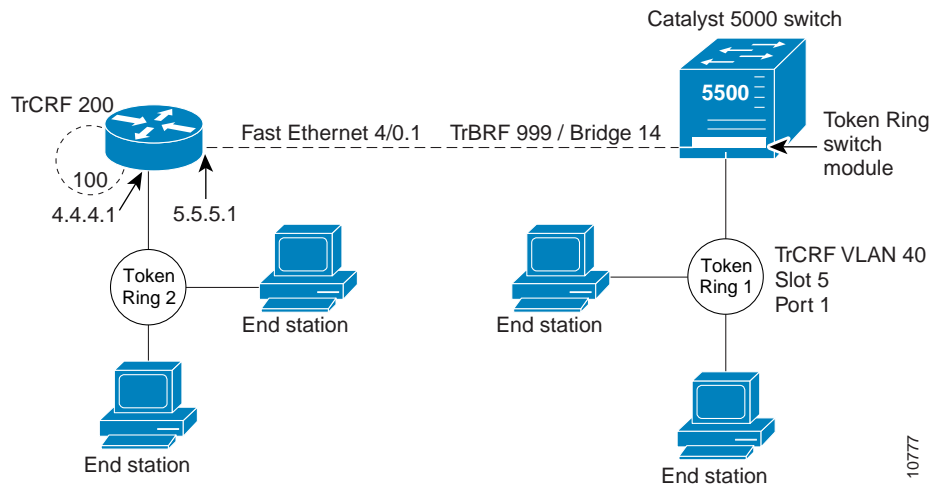

The following is the configuration for the router:

```
ip routing
interface TokenRing 3/1
 ip address 4.4.4.1 255.255.255.0
!
interface FastEthernet4/0.1
 ip address 5.5.5.1 255.255.255.0
 encapsulation tr-isl trbrf 999 bridge-num 14
 multiring trcrf-vlan 200 ring 100
 multiring all
```

The following is the configuration for the Catalyst 5000 switch with the Token Ring switch module in slot 5. In this configuration, the Token Ring port 5/1 is assigned to the TrCRF VLAN 40.

```
#vtp
set vtp domain trisl
set vtp mode server
set vtp v2 enable
#drip
set tokenring reduction enable
set tokenring distrib-crf disable
#vlans
set vlan 999 name trbrf type trbrf bridge 0xe stp ibm
set vlan 200 name trcrf200 type trcrf parent 999 ring 0x64 mode srb
set vlan 40 name trcrf40 type trcrf parent 999 ring 0x1 mode srb
#add token port to trcrf 40
set vlan 40 5/1
set trunk 1/2 on
```

IP Routing Source-Route Frames between a TRISL VLAN and an Ethernet ISL VLAN Example

Figure 57 illustrates IP routing source-route frames between a TRISL VLAN and an Ethernet ISL VLAN.

Figure 57 IP Routing Source-Routed Frames between a TRISL VLAN and an Ethernet ISL VLAN

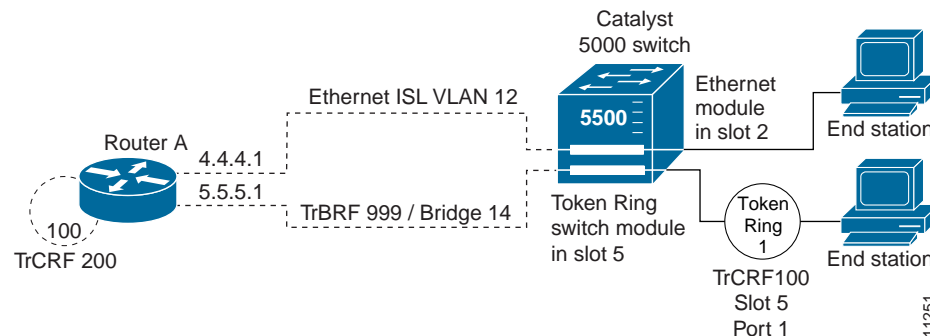

The following is the configuration for the router:

```
interface FastEthernet4/0.1
 ip address 5.5.5.1 255.255.255.0
 encapsulation tr-isl trbrf-vlan 999 bridge-num 14
 multiring trcrf-vlan 200 ring 100
 multiring all
!
interface FastEthernet4/0.2
 ip address 4.4.4.1 255.255.255.0
 encapsulation isl 12
```

The following is the configuration for the Catalyst 5000 switch with the Ethernet module in slot 2 and a Token Ring switch module in slot 5. In this configuration, the Token Ring port is assigned with TrCRF VLAN 100 and the Ethernet port is assigned with VLAN 12.

```
#vtp
set vtp domain trisl
set vtp mode server
set vtp v2 enable
#drip
set tokenring reduction enable
set tokenring distrib-crf disable
#vlans
set vlan 999 name trbrf type trbrf bridge 0xe stp ibm
set vlan 100 name trcrf100 type trcrf parent 999 ring 0x1 mode srb
set vlan 200 name trcrf200 type trcrf parent 999 ring 0x64 mode srb
set vlan 12 name eis12 type ethernet
#add token port to trcrf 100
set vlan 100 5/1
#add ethernet
set vlan 12 2/1
set trunk 1/2 on
```

IP Routing Source-Routed Frames between TRISL VLANs Example

Figure 58 illustrates IP routing source-routed frames between two TrBRF VLANs.

Figure 58 IP Routing Source-Routed Frames between TrBRF VLANs

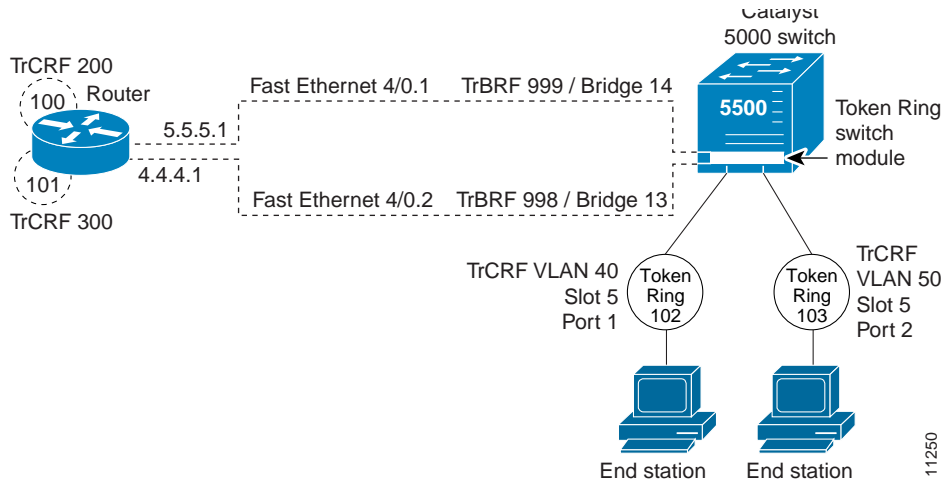

The following is the configuration for the router:

```
interface FastEthernet4/0.1
 ip address 5.5.5.1 255.255.255.0
 encapsulation tr-isl trbrf-vlan 999 bridge-num 14
 multiring trcrf-vlan 200 ring 100
 multiring all
!
interface FastEthernet4/0.2
 ip address 4.4.4.1 255.255.255.0
 encapsulation tr-isl trbrf-vlan 998 bridge-num 13
 multiring trcrf-vlan 300 ring 101
 multiring all
```

The following is the configuration for the Catalyst 5000 switch with the Token Ring switch module in slot 5. In this configuration, the Token Ring port attached to ring 102 is assigned with TrCRF VLAN 40 and the Token Ring port attached to ring 103 is assigned with TrCRF VLAN 50.

```
#vtp
set vtp domain trisl
set vtp mode server
set vtp v2 enable
#drip
set tokenring reduction enable
set tokenring distrib-crf disable
#vlans
set vlan 999 name trbrf type trbrf bridge 0xe stp ibm
set vlan 200 name trcrf200 type trcrf parent 999 ring 0x64 mode srb
set vlan 40 name trcrf40 type trcrf parent 999 ring 0x66 mode srb
set vlan 998 name trbrf type trbrf bridge 0xd stp ibm
set vlan 300 name trcrf300 type trcrf parent 998 ring 0x65 mode srb
set vlan 50 name trcrf50 type trcrf parent 998 ring 0x67 mode srb
#add token port to trcrf 40
set vlan 40 5/1
#add token port to trcrf 50
set vlan 50 5/2
set trunk 1/2 on
```

IPX Routing Non-Source-Routed Frames between a TRISL VLAN and a Token Ring Interface Example

Figure 59 shows IPX routing non-source-routed frames between a TRISL VLAN and a Token Ring interface.

Figure 59 *IPX Routing Non-Source-Routed Frames between a TRISL VLAN and a Token Ring Interface Example*

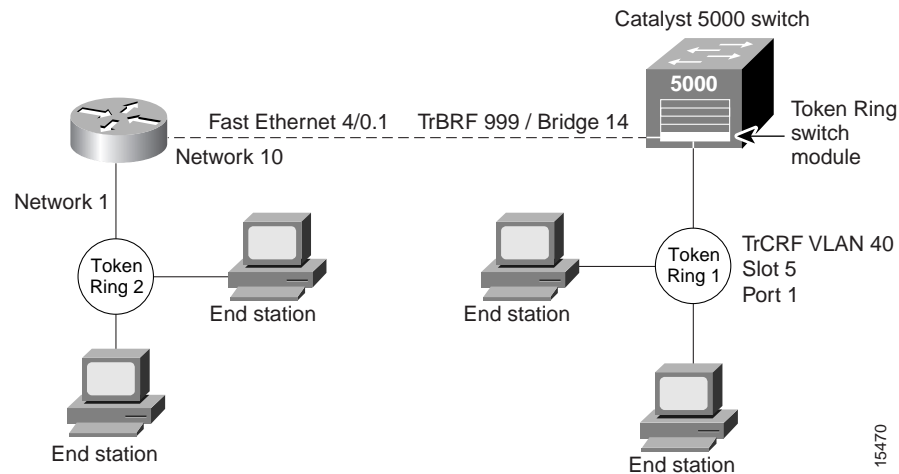

The following is the configuration for the router:

```
ipx routing
interface TokenRing 3/1
 ipx network 1
!
interface FastEthernet4/0.1
 ipx network 10
 encapsulation tr-isl trbrf 999 bridge-num 14
```

The following is the configuration for the Catalyst 5000 switch with the Token Ring switch module in slot 5. In this configuration, the Token Ring port attached to ring 1 is assigned to the TrCRF VLAN 40.

```
#vtp
set vtp domain trisl
set vtp mode server
set vtp v2 enable
#drip
set tokenring reduction enable
set tokenring distrib-crf disable
#vlans
set vlan 999 name trbrf type trbrf bridge 0xe stp ieee
set vlan 40 name trcrf40 type trcrf parent 999 ring 0x1 mode srt
#add token port to trcrf 40
set vlan 40 5/1
set trunk 1/2 on
```

IPX Routing Source-Routed Frames between a TRISL VLAN and a Token Ring Interface Example

Figure 60 shows IPX routing source-routed frames between a TRISL VLAN and a Token Ring interface.

Figure 60 IPX Routing Source-Routed Frames between a TRISL VLAN and a Token Ring Interface

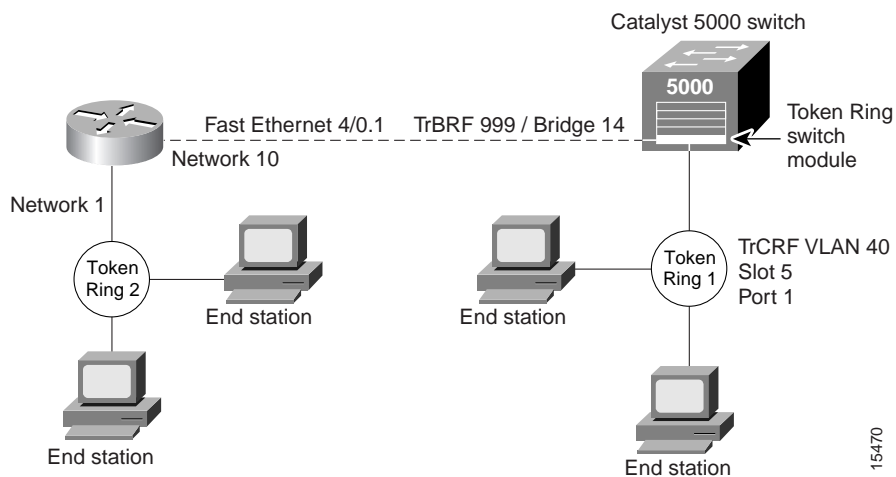

The following is the configuration for the router:

```
ipx routing
!
interface TokenRing 3/1
 ipx network 1
 multiring all
!
interface FastEthernet4/0.1
 ipx network 10
 encapsulation tr-isl trbrf 999 bridge-num 14
 multiring trcrf-vlan 200 ring 100
 multiring all
```

The following is the configuration for the Catalyst 5000 switch with the Token Ring switch module in slot 5. In this configuration, the Token Ring port attached to ring 1 is assigned to the TrCRF VLAN 40.

```
#vtp
set vtp domain trisl
set vtp mode server
set vtp v2 enable
#drip
set tokenring reduction enable
set tokenring distrib-crf disable
#vlans
set vlan 999 name trbrf type trbrf bridge 0xe stp ibm
set vlan 200 name trcrf200 type trcrf parent 999 ring 0x64 mode srb
set vlan 40 name trcrf40 type trcrf parent 999 ring 0x1 mode srb
#add token port to trcrf 40
set vlan 40 5/1
set trunk 1/2 on
```

IPX Routing Source-Route Frames between a TRISL VLAN and an Ethernet ISL VLAN Example

Figure 61 shows IPX routing source-route frames between a TRISL VLAN and an Ethernet ISL VLAN.

Figure 61 IPX Routing Source-Routed Frames between a TRISL VLAN and an Ethernet ISL VLAN

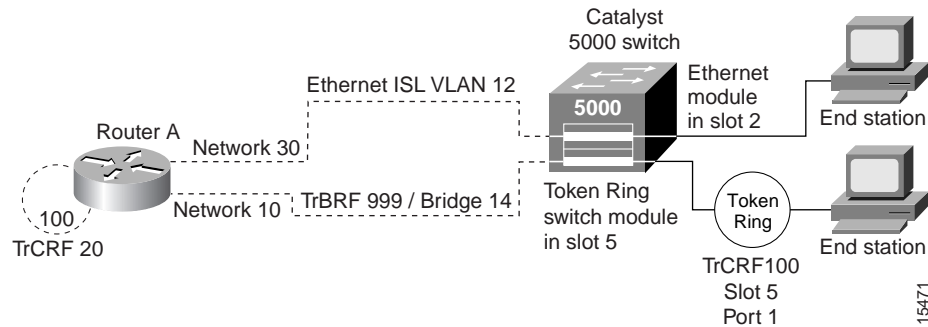

The following is the configuration for the router:

```
ipx routing
interface FastEthernet4/0.1
 ipx network 10
 encapsulation tr-isl trbrf-vlan 999 bridge-num 14
 multiring trcrf-vlan 20 ring 100
 multiring all
!
interface FastEthernet4/0.2
 ipx network 30
 encapsulation isl 12
```

The following is the configuration for the Catalyst 5000 switch with the Ethernet module in slot 2 and a Token Ring switch module in slot 5. In this configuration, the Token Ring port is assigned with TrCRF VLAN 100 and the Ethernet port is assigned with VLAN 12.

```
#vtp
set vtp domain trisl
set vtp mode server
set vtp v2 enable
#drip
set tokenring reduction enable
set tokenring distrib-crf disable
#vlans
set vlan 999 name trbrf type trbrf bridge 0xe stp ibm
set vlan 100 name trcrf100 type trcrf parent 999 ring 0x1 mode srb
set vlan 20 name trcrf20 type trcrf parent 999 ring 0x64 mode srb
set vlan 12 name default type eis12
#add token port to trcrf 100
set vlan 100 5/1
#add ethernet
set vlan 12 2/1
set trunk 1/2 on
```

IPX Routing Source-Routed Frames between TRISL VLANs Example

Figure 62 shows IPX source-routed frames between TRISL VLANs.

Figure 62 IPX Routing Source-Routed Frames between TRISL VLANs

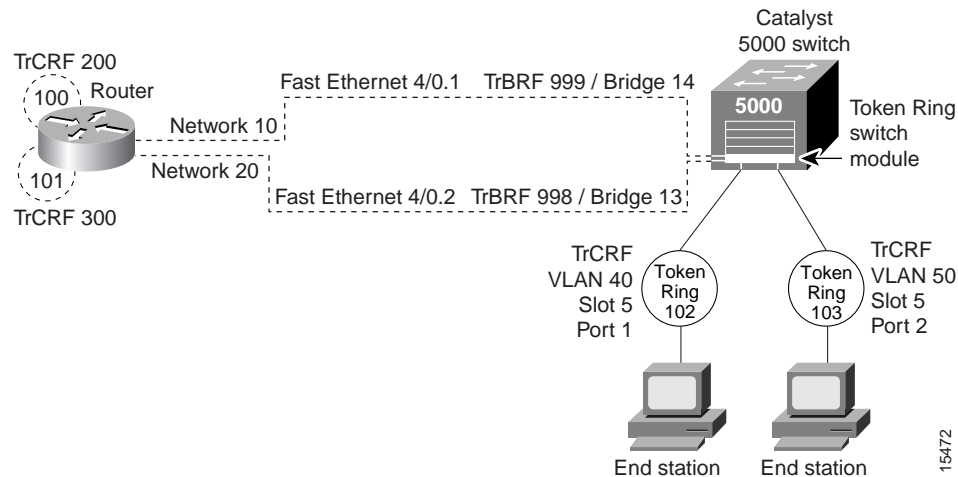

The following is the configuration for the router:

```
ipx routing
interface FastEthernet4/0.1
 ipx network 10
 encapsulation tr-isl trbrf-vlan 999 bridge-num 14
 multiring trcrf-vlan 200 ring 100
 multiring all
!
interface FastEthernet4/0.2
 ipx network 20
 encapsulation tr-isl trbrf-vlan 998 bridge-num 13
 multiring trcrf-vlan 300 ring 101
 multiring all
```

The following is the configuration for the Catalyst 5000 switch with the Token Ring switch module in slot 5. In this configuration, the Token Ring port attached to ring 102 is assigned with TrCRF VLAN 40 and the Token Ring port attached to ring 103 is assigned with TrCRF VLAN 50.

```
#vtp
set vtp domain trisl
set vtp mode server
set vtp v2 enable
#drip
set tokenring reduction enable
set tokenring distrib-crf disable
#vlans
set vlan 999 name trbrf type trbrf bridge 0xe stp ibm
set vlan 200 name trcrf200 type trcrf parent 999 ring 0x64 mode srb
set vlan 40 name trcrf40 type trcrf parent 999 ring 0x66 mode srb
set vlan 998 name trbrf type trbrf bridge 0xd stp ibm
```

15472

```

set vlan 300 name trcrf300 type trcrf parent 998 ring 0x65 mode srb
set vlan 50 name trcrf50 type trcrf parent 998 ring 0x67 mode srb
#add token port to trcrf 40
set vlan 40 5/1
#add token port to trcrf 50
set vlan 50 5/2
set trunk 1/2 on

```

SRB between Token Ring and TRISL VLAN Example

Figure 63 illustrates SRB between a Token Ring interface on a router and a TRISL VLAN.

Figure 63 SRB between a Token Ring Interface and TRISL VLAN

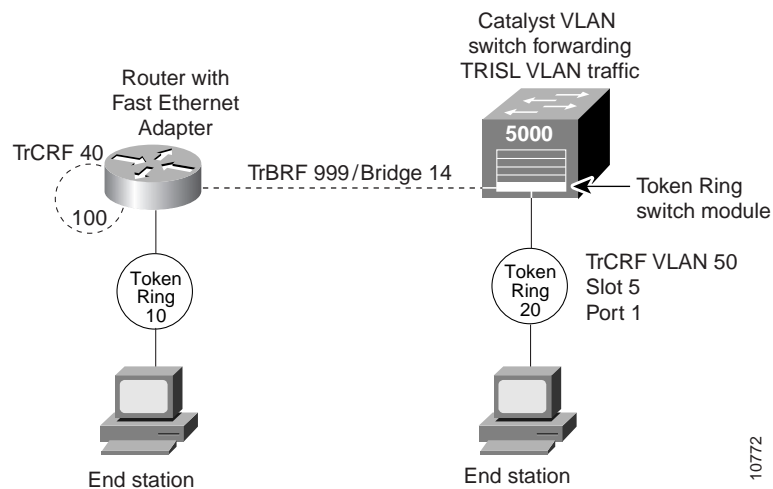

The following is the configuration for the router with the Token Ring interface:

```

source-bridge ring-group 100
!
interface TokenRing3/1
ring speed 16
source-bridge 10 1 100
source-bridge spanning
!
interface FastEthernet4/0.1
encapsulation tr-isl trbrf-vlan 999 bridge-num 14
source-bridge trcrf-vlan 40 ring-group 100
source-bridge spanning
!

```

The following is the configuration for the Catalyst 5000 switch:

```

#vtp
set vtp domain trisl
set vtp mode server
set vtp v2 enable
#drip
set tokenring reduction enable
set tokenring distrib-crf disable

```

```
#vlangs
set vlan 999 name trbrf type trbrf bridge 0xe stp ibm
set vlan 40 name trcrf40 type trcrf parent 999 ring 0x64 mode srb
set vlan 50 name trcrf50 type trcrf parent 999 ring 0x14 mode srb
#add token port to trcrf 50
set vlan 50 5/1
```

SRB between TRISL VLANs Example

Figure 64 illustrates SRB between two TrCRF VLANs.

Figure 64 SRB between TRISL VLANs

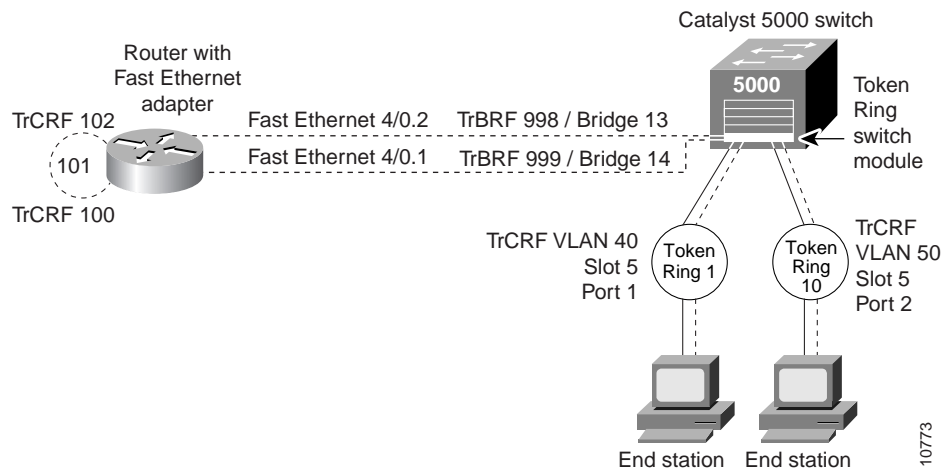

The following is the configuration for the router:

```
source-bridge ring-group 101
!
interface FastEthernet4/0.1
 encapsulation tr-isl trbrf 999 bridge-num 14
 source-bridge trcrf-vlan 100 ring-group 101
 source-bridge spanning
!
interface FastEthernet4/0.2
 encapsulation tr-isl trbrf 998 bridge-num 13
 source-bridge trcrf-vlan 102 ring-group 101
 source-bridge spanning
```

The following is the configuration for the Catalyst 5000 switch with the Token Ring switch module in slot 5. The Token Ring port on 5/1 is assigned to TrCRF VLAN 40 and the Token Ring port on 5/2 is assigned to TrCRF VLAN 50.

In this configuration, the keyword *name* is optional and *srb* is the default mode.

```
#vtp
set vtp domain trisl
set vtp mode server
set vtp v2 enable
#drip
set tokenring reduction enable
set tokenring distrib-crf disable
#vlangs
set vlan 999 name trbrf type trbrf bridge 0xe stp ibm
set vlan 100 name trcrf100 type trcrf parent 999 ring 0x65 mode srb
```

```

set vlan 40 name trcrf40 type trcrf parent 999 ring 0x1 mode srb
set vlan 998 name trbrf type trbrf bridge 0xd stp ibm
set vlan 102 name trcrf102 type trcrf parent 998 ring 0x65 mode srb
set vlan 50 name trcrf50 type trcrf parent 998 ring 0xa mode srb
#add token port to trcrf 40
set vlan 40 5/1
#add token port to trcrf 50
set vlan 50 5/2
#enable trunk
set trunk 1/2 on

```

Transparent Bridging between Token Ring and TRISL VLAN Example

Figure 65 illustrates transparent bridging between a router's Token Ring interface and a TRISL VLAN.

Figure 65 Transparent Bridging between Token Ring and TRISL VLAN

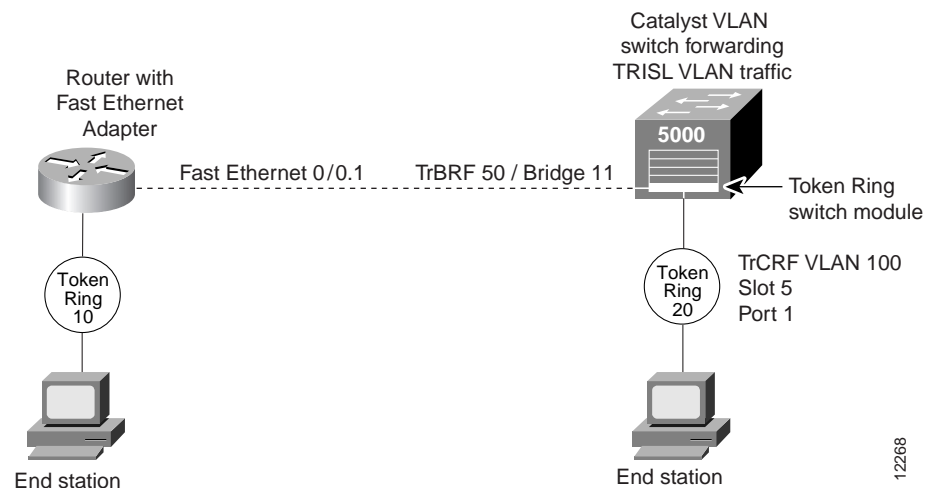

The following is the configuration for the router:

```

bridge 1 protocol ieee
!
interface Tokenring0
 bridge-group 1
!
interface FastEthernet0/0.1
 encapsulation tr-isl trbrf-vlan 50 bridge-num 11
 bridge-group 1

```

The following is the configuration for the Catalyst 5000 switch with a Token Ring switch module in slot 5:

```

#vtp
set vtp domain trisl
set vtp mode server
set vtp v2 enable
#drip
set tokenring reduction enable
set tokenring distrib-crf disable
#vlans
set vlan 50 name trbrf50 type trbrf bridge 0xb stp ieee
set vlan 100 name trcrf100 type trcrf ring 0x14 parent 50 mode srt
#enable trunk

```

```

set trunk 1/2 on
#add token port to trcrf 100
set vlan 100 5/1

```

SR/TLB between a TRISL VLAN and an Ethernet Interface Example

Figure 66 illustrates SR/TLB between a TRISL VLAN and an Ethernet interface.

Figure 66 SR/TLB between a TRISL VLAN and an Ethernet Interface

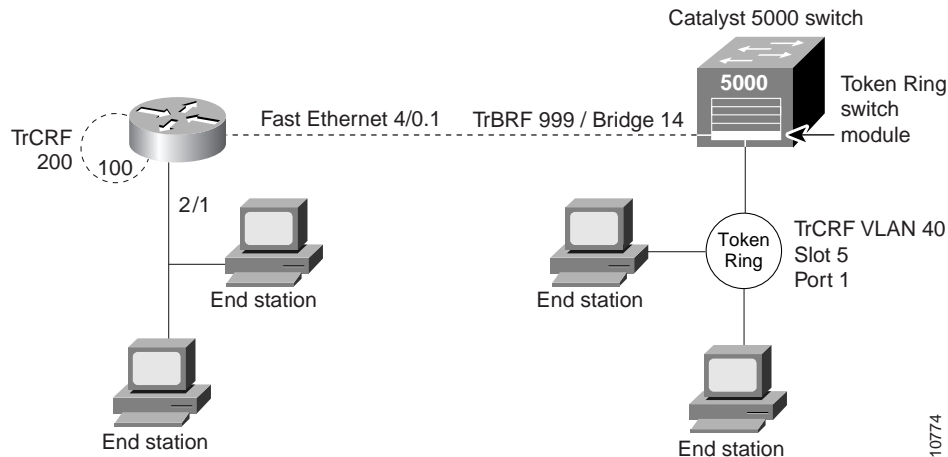

The following is the configuration for the router:

```

source-bridge ring-group 100
source-bridge transparent 100 101 6 1
!
interface Ethernet2/0
 bridge-group 1
!
interface FastEthernet4/0.1
 encapsulation tr-isl trbrf-vlan 999 bridge-num 14
 source-bridge trcrf-vlan 200 ring-group 100
 source-bridge spanning
!
bridge 1 protocol ieee
!

```

The following is the configuration for the Catalyst 5000 switch with an Ethernet card in module 5 and using port 1. The Token Ring port on 5/1 is assigned to TrCRF VLAN 40.

```

#vtp
set vtp domain trisl
set vtp mode server
set vtp v2 enable
#drip
set tokenring reduction enable
set tokenring distrib-crf disable
#vlans
set vlan 999 name trbrf999 type trbrf bridge 0xe stp ibm
set vlan 200 name trcrf200 type trcrf parent 999 ring 0x64 mode srb
set vlan 40 name trcrf40 type trcrf parent 999 ring 0x1 mode srb
#add token port to trcrf 40
set vlan 40 5/1

```

```
#enable trunk
set trunk 1/2 on
```

SR/TLB between a TRISL VLAN and an Ethernet ISL VLAN Example

Figure 67 illustrates SR/TLB between a TRISL VLAN and an Ethernet ISL VLAN.

Figure 67 SR/TLB between a TRISL VLAN and an Ethernet ISL VLAN

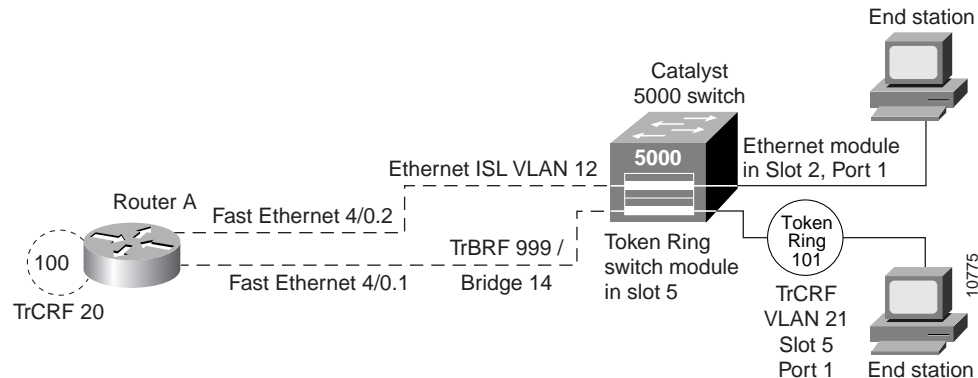

The following is the configuration for the router:

```
source-bridge ring-group 100
source-bridge transparent 100 101 6 1
!
interface FastEthernet4/0.1
 encapsulation tr-isl trbrf-vlan 999 bridge-num 14
 source-bridge trcrf-vlan 20 ring-group 100
 source-bridge spanning
!
interface FastEthernet4/0.2
 encapsulation isl 12
 bridge-group 1
!
bridge 1 protocol ieee
```

The following is the configuration for the Catalyst 5000 switch with an Ethernet module in slot 2 and a Token Ring switch module in slot 5. In this configuration, the Token Ring port attached to ring 101 is assigned to TrCRF VLAN 21, and the router's virtual ring is assigned to TrCRF VLAN 20.

```
#vtp
set vtp domain trisl
set vtp mode server
set vtp v2 enable
#drip
set tokenring reduction enable
set tokenring distrib-crf disable
#vlans
set vlan 999 type trbrf bridge 0xe stp ibm
set vlan 20 type trcrf parent 999 ring 0x64 mode srb
set vlan 21 type trcrf parent 999 ring 0x65 mode srb
#add token port to trcrf 21
set vlan 21 5/1
#add ethernet
```

```

set vlan 12 type ethernet
set vlan 12 2/1
set trunk 1/2 on

```

TRISL with Fast EtherChannel

Figure 68 illustrates TRISL with Fast EtherChannel.

Figure 68 Sample Configuration of TRISL with Fast EtherChannel

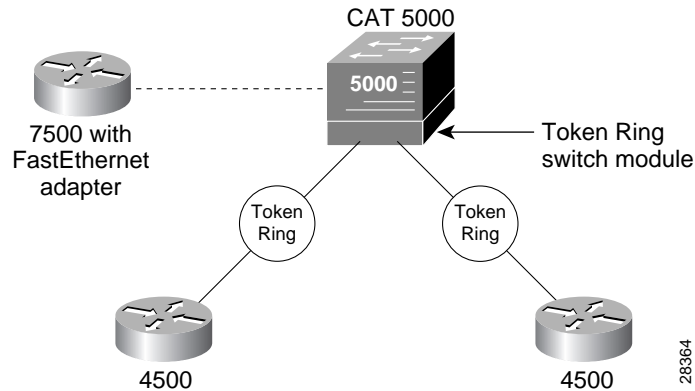

The following is the configuration for the Cisco 7500:

```

source-bridge ring-group 50
interface Port-channel1
  no ip address
  no ip directed-broadcast
  no ip route-cache distributed
  hold-queue 300 in
interface Port-channel1.1
  encapsulation tr-is1 trbrf-vlan 20 bridge-num 1
  ip address 10.131.25.1 255.255.255.0
  no ip redirects
  no ip directed-broadcast
  source-bridge trcrf-vlan 23 ring-group 50
  source-bridge spanning
interface Port-channel1.2
  encapsulation tr-is1 trbrf-vlan 30 bridge-num 2
  ip address 10.131.24.1 255.255.255.0
  no ip redirects
  no ip directed-broadcast
  source-bridge trcrf-vlan 33 ring-group 50
  source-bridge spanning
interface FastEthernet4/1/0
  no ip address
  no ip directed-broadcast
  no ip route-cache distributed
  channel-group 1
interface FastEthernet4/1/1
  no ip address
  no ip directed-broadcast
  no ip route-cache distributed
  channel-group 1

```

The following is the configuration for the Catalyst 5000 Switch:

```
set vlan 10 name VLAN0010 type ethernet mtu 1500 said 100010 state active
set vlan 20 name VLAN0020 type trbrf mtu 4472 said 100020 state active bridge 0x1 stp
ieee
set vlan 30 name VLAN0030 type trbrf mtu 4472 said 100030 state active bridge 0x2 stp
ieee

set vlan 22 name VLAN0022 type trcrf mtu 4472 said 100022 state active parent 20 ring
0x1 mode srt aremaxhop 7 stemaxhop 7
set vlan 23 name VLAN0023 type trcrf mtu 4472 said 100023 state active parent 20 ring
0x32 mode srt aremaxhop 7 stemaxhop 7
set vlan 32 name VLAN0032 type trcrf mtu 4472 said 100032 state active parent 30 ring
0x2 mode srt aremaxhop 7 stemaxhop 7
set vlan 33 name VLAN0033 type trcrf mtu 4472 said 100033 state active parent 30 ring
0x32 mode srt aremaxhop 7 stemaxhop 7

set port channel 1/1-2 on

set trunk 1/1 on isl 1-1005
set trunk 1/2 on isl 1-1005
add token port to crf 22
set vlan 22 5/1
add token port to crf 32
set vlan 32 5/2
```

TRISL with Fast EtherChannel only runs on the Cisco 7500. The MTU size can be set to more than 1500 if all the members of the port channel interface are 2FE/ISL adaptors. If, on the other hand, any member of the port channel interface is a non 2FE/ISL adaptor, then the MTU size is not configurable and defaults to 1500 bytes. Also, only IP utilizes all four links. Spanning-Tree Protocol must be disabled if transparent bridging is configured on the FEC. The port-channel interface is the routed interface. Do not enable layer 3 addresses on the physical Fast Ethernet interfaces. Do not assign bridge groups on the physical Fast Ethernet interfaces because it creates loops. Also, you must disable Spanning-Tree Protocol if transparent bridging is configured on the FEC.

