



# Configuring Token Ring Route Switch Module

---

This chapter describes how to configure Token Ring VLAN on the route switch module (RSM). For a complete description of the commands mentioned in this chapter, refer to the *Cisco IOS Bridging and IBM Networking Command Reference, Volume I*. To locate documentation of other commands that appear in this chapter, use the command reference master index or search online.

The Token Ring VLAN support on the RSM adds the capability to do multiprotocol routing and bridging for Token Ring VLANs on the RSM. The RSM is a router module running Cisco IOS software that plugs into a Token Ring switch backplane. This section provides a brief overview of Token Ring switching.

- Technology Overview, page 173
- Related Documents, page 177
- Prerequisites, page 178
- Configuration Tasks, page 178
- Verifying TRRSM, page 181
- Monitoring Statistics, page 182
- Configuration Examples, page 183

## Technology Overview

The term switching was originally used to describe packet-switch technologies such as Link Access Procedure, Balanced (LAPB), Frame Relay, Switched Multimegabit Data Service (SMDS), and X.25. Today, LAN switching refers to a technology that is similar to a bridge in many ways.

Like bridges, switches connect LAN segments and use information contained in the frame to determine the segment to which a datagram needs to be transmitted. Switches, however, operate at much higher speeds than bridges, and can support new functionality, such as virtual LANs (VLANs). See the “VLAN” and “Token Ring VLANs” sections below.

Token Ring switches first appeared in 1994. The first-generation Token Ring switches can be divided into two basic categories:

- Processor-based switches—These switches use reduced instruction set computer (RISC) processors to switch Token Ring frames. Although they typically have a lot of function, they are slow and relatively expensive. These switches have been deployed mainly as backbone switches because of their high cost.
- Application-specific integrated circuit (ASIC)-based switches with limited functionality—These switches are fast and relatively inexpensive, but have very limited function. Typically, they offer little to no filtering, limited management information, limited support for bridging modes, and limited VLANs. Today, although these switches are less expensive than processor-based switches, they are still too expensive and limited for widespread use of dedicated Token Ring to the desktop.

In 1997, a second generation of Token Ring switches was introduced. Cisco's second-generation Token Ring switches use ASIC-based switching, but they provide increased functionality resulting in a higher speed and lower cost. They also provide a wider variety of function than their predecessors, including support for multiple bridging modes, Dedicated Token Ring (DTR) on all ports, high-port density, high-speed links, filtering, Remote Monitoring (RMON) management, broadcast control, and flexible VLANs.

The family of second-generation Token Ring switches can be used for backbone switching, workgroup microsegmentation, and dedicated Token Ring to the desktop. Token Ring switches currently being offered include:

- The Catalyst 3900, which is a stackable workgroup switch that provides support for all switching modes, filtering, RMON, DTR, and SNMP management, as well as support for Asynchronous Transmission Mode (ATM) and Inter-Switch Link (ISL).
- The Catalyst 3920, which is also a stackable workgroup switch that provides support for all switching modes, filtering, RMON, DTR, and SNMP management.
- The Catalyst 5000, which is a modular switch that supports Ethernet, Fast Ethernet, Fiber Distributed Data Interface (FDDI), ATM, and now Token Ring.

The Catalyst Token Ring switches support the following bridging modes: source-route bridging (SRB), source-route transparent bridging (SRT), and source-route switching.

## Usability of Switching

The traditional method of connecting multiple Token Ring segments is to use a SRB. For example, bridges are often used to link workgroup rings to the backbone ring. However, the introduction of the bridge can significantly reduce performance at the user's workstation. Further problems may be introduced by aggregate traffic loading on the backbone ring.

To maintain performance and avoid overloading the backbone ring, you can locate servers on the same ring as the workgroup that needs to access the server. However, dispersing the servers throughout the network makes them more difficult to back up, administer, and secure than if they are located on the backbone ring. Dispersing the servers also limits the number of servers that particular stations can access.

Collapsed backbone routers may offer greater throughput than bridges, and can interconnect a larger number of rings without becoming overloaded. Routers provide both bridging and routing functions between rings and have sophisticated broadcast control mechanisms. These mechanisms become increasingly important as the number of devices on the network increases.

The main drawback of using routers as the campus backbone is the relatively high price per port and the fact that the throughput typically does not increase as ports are added. A Token Ring switch is designed to provide wire speed throughput regardless of the number of ports in the switch. In addition, the Catalyst 3900 Token Ring switch can be configured to provide very low latency between Token Ring ports by using cut-through switching.

As a local collapsed backbone device, a Token Ring switch offers a lower per-port cost and can incur lower interstation latency than a router. In addition, the switch can be used to directly attach large numbers of clients or servers, thereby replacing concentrators. Typically, a Token Ring switch is used in conjunction with a router, providing a high-capacity interconnection between Token Ring segments while retaining the broadcast control and wide-area connectivity provided by the router.

## VLAN

A VLAN is a logical group of LAN segments, independent of physical location, with a common set of requirements. For example, several end stations might be grouped as a department, such as engineering or accounting. If the end stations are located close to one another, they can be grouped into a LAN segment. If any of the end stations are on a different LAN segment, such as different buildings or locations, they can be grouped into a VLAN that has the same attributes as a LAN even though the end stations are not all on the same physical segment. The information identifying a packet as part of a specific VLAN is preserved across a Catalyst switch connection to a router or another switch if they are connected via trunk ports, such as ISL or ATM.

## Token Ring VLANs

Because a VLAN is essentially a broadcast domain, a Token Ring VLAN is slightly more complex than an Ethernet VLAN. In transparent bridging, there is only one type of broadcast frame and, therefore, only one level of broadcast domain and one level of VLAN. In source routing, however, there are two types of broadcast frames:

- Those that are confined to a single ring
- Those that traverse the bridged domain

Therefore, there are two levels of VLANs in a Token Ring switched network. These two categories of broadcast frames result in a broadcast domain that is hierarchical in nature, just as a local ring domain can exist only within a domain of all the inter-connected rings.

The first level is the Token Ring Concentrator Relay Function (TrCRF). In a Token Ring VLAN, logical ring domains are formed by defining groups of ports that have the same ring number. The IEEE calls such a port group a Concentrator Relay Function (CRF). On Catalyst switches, such a grouping of Token Ring ports is called a Token Ring CRF (TrCRF). At this level, the VLAN is a logical ring and, as such, is assigned a ring number. On a Token Ring switch, the logical ring (TrCRF) contains one or more physical ports. Source Route Switching (SRS) is used to forward frames within a TrCRF based on Media Access Control (MAC) address or Route Descriptor. On an RSM, a logical ring (TrCRF) can be defined that does not contain any physical ports, but rather is used only in processing source-routed traffic to terminate the RIF.

The second level of VLAN is the Token Ring Bridge Relay Function (TrBRF). This is the parent VLAN to which TrCRF VLANs are assigned. The domain of interconnected rings is formed using an internal multipoint bridge function that the IEEE calls a Bridge Relay Function (BRF). On Catalyst switches, such a grouping of logical rings is called a Token Ring BRF (TrBRF). At this level, the VLAN is a logical bridge and, as such, is assigned a bridge number. The TrBRF is responsible for forwarding frames between groups of ports with the same ring number (TrCRFs) via either SRB or SRT.

Figure 69 depicts the relationship between TrCRF and TrBRF VLANs.

**Figure 69** Token Ring VLAN Support on the RSM

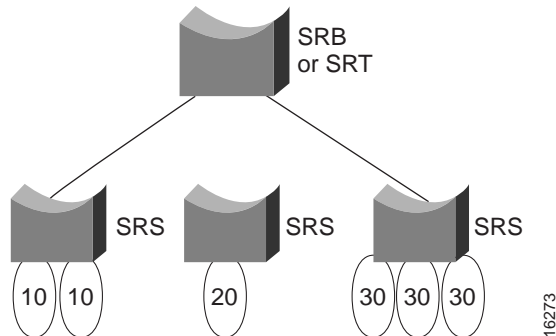

## Token Ring VLAN Support on the RSM

The Token Ring VLAN support on the RSM adds the capability to do multi-protocol routing and bridging for Token Ring VLANs on the RSM. The RSM can be used alone to do inter-VLAN routing, or it can be paired with a Catalyst VIP2 to provide external network connections with the same port adapters used on Cisco 7500 series routers. The RSM/VIP2 combination provides routing between VLANs and Catalyst VIP2 port adapters. A complete description of the RSM can be found in the *Catalyst 5000 Series Route Switch Module Installation and Configuration Note* and the *Route Switch Module Catalyst VIP2-15 and VIP2-40 Installation and Configuration Note*.

The Token Ring VLAN support on the RSM adds the following functionality to the Catalyst 5000 switch:

- IP routing for source-routed and non-source-routed frames between Token Ring (TrBRF) and/or Ethernet VLANs and VIP2 interfaces
- IPX routing for source-routed and non-source-routed frames between Token Ring (TrBRF) and/or Ethernet VLANs and VIP2 interfaces
- Source-route bridging SRB between Token Ring (TrBRF) VLANs and VIP2 interfaces
- Source-route translational bridging (SR/TLB) between Token Ring (TrBRF) VLANs and Ethernet VLANs and VIP2 interfaces
- Source-route transparent bridging (SRT) between Token Ring (TrBRF) VLANs and SRT-capable VLANs and VIP2 interfaces

Both APPN and DLSw+ are supported for Token Ring VLANs on the RSM. However, RSRB is not supported on the RSM.

For information on how Token Ring VLANs are implemented on switches, refer to the *Catalyst Token Ring Switching Implementation Guide*, the *Catalyst 5000 Series Token Ring Configuration Notes*, the *Catalyst 3900 Token Ring Switching User Guide*, and the *Catalyst 3920 Token Ring Switching User Guide*.

The RSM is a router module running Cisco IOS router software that directly interfaces (plugs into) the Catalyst switch backplane. From the Token Ring VLAN perspective, the interface to the RSM is at the Token Ring bridged network (TrBRF) level. With the RSM, it is possible to route or bridge between separate Token Ring and Ethernet domains.

When routing or bridging between TrBRF VLANs that are defined as SRB domains, it is necessary to create a logical ring on the RSM for proper RIF processing. This logical ring is defined as a TrCRF VLAN that does not contain any external Token Ring switch ports. Figure 70 illustrates the logical view of IP routing between two source-route bridged VLANs on the RSM. In this view, the RSM appears to have an interface to both ring 100 and ring 110.

**Figure 70 Logical View of VLAN Support on the RSM**

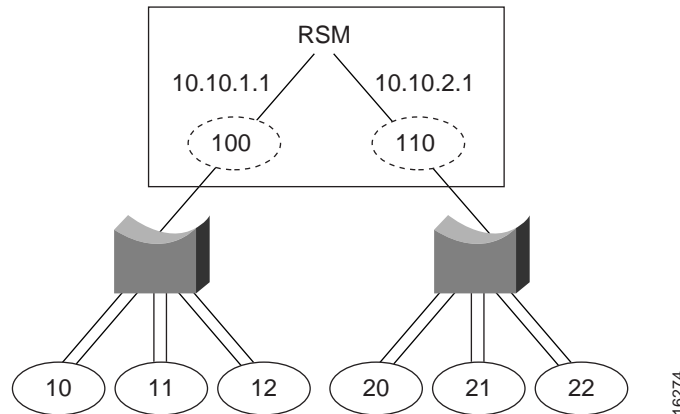

The Token Ring RSM feature is supported on the RSM in the Catalyst 5000 platform. Support for the Token Ring RSM feature was first introduced in the Cisco IOS 11.3(5)T. The Token Ring RSM feature is supported on all RSM IOS 12.0 T software release images. A list of the supported Cisco IOS Releases and software images are located in the *Release Notes for Catalyst 5000 Series RSM/VIP2 Cisco IOS 12.0 T Software Releases* publication. For a complete functional description of the RSM, refer to the *Catalyst 5000 Series RSM Installation and Configuration Note*.

## Related Documents

For related information on this feature, see the following documents:

- *Cisco IOS Bridging and IBM Networking Configuration Guide*
- *Cisco IOS Bridging and IBM Networking Command Reference, Volume I*
- *Catalyst 5000 Series RSM Installation and Configuration Note*
- *Catalyst Token Ring Switching Implementation Guide*
- *Catalyst 5000 Series Token Ring Configuration Notes*
- *Catalyst 3900 Token Ring Switching User Guide*
- *Catalyst 3920 Token Ring Switching User Guide.*
- *Catalyst 5000 Series Route Switch Module Installation and Configuration Note*
- *Route Switch Module Catalyst VIP2-15*
- *Release Notes for Catalyst 5000 Series RSM/VIP2 Cisco IOS 12.0 T Software Releases*
- *VIP2-40 Installation and Configuration Note*

## Prerequisites

Before you configure bridging or routing for Token Ring VLAN interfaces in the RSM, configure the VLANs on the Supervisor engine module.

To configure a VLAN on the Supervisor engine module, use the following command in privileged mode:

Command	Purpose
<pre>set vlan vlan_num [name name] [state {active   suspend}] [mtu mtu] ring ring_number parent vlan_num [mode {srt   srb}] [backupcrf {off   on}] [aremaxhop hopcount] [stemaxhop hopcount]</pre>	Configures a TrCRF or TrBRF on the Supervisor engine module.

## Configuration Tasks

To configure and monitor Token Ring VLAN support on the RSM, perform one or more of the following tasks:

- Configuring IP Routing
- Configuring IPX Routing
- Configuring Source-Route Bridging
- Configuring Source-Route Transparent Bridging
- Configuring Source-Route Translational Bridging
- Configuring Automatic Spanning Tree



### Note

For information on configuring DLSw+, refer to the “Configuring Data-Link Switching Plus” chapter in this publication and the “DLSw+ Commands” chapter in the *Cisco IOS Bridging and IBM Networking Command Reference, Volume I*.

## Configuring IP Routing

The IP routing for Token Ring VLANs feature extends IP routing capabilities to include support for routing IP frame types in Token Ring VLAN configurations. IP can be routed between:

- TrBRF VLANs
- TrBRFs and the VIP2
- TrBRFs and Ethernet VLANs

To configure IP routing on an RSM, use the following commands, beginning in global configuration mode:

	Command	Purpose
Step 1	<code>ip routing</code>	Enables IP routing on the RSM.
Step 2	<code>interface vlan <i>vlanid</i> type [trbrf   ethernet]</code>	Configures a Token Ring or Ethernet interface on the RSM.
Step 3	<code>ip address <i>ip-address mask</i></code>	Sets a primary IP address for an interface.

You can configure an RSM to route source-routed traffic by creating a “pseudo-ring” to terminate the RIF path on a ring and by enabling the collection and use of RIF information.

To route source-routed traffic, use the following additional commands in interface configuration mode

	Command	Purpose
Step 1	<code>multiring trcrf-vlan <i>vlanid</i> ring <i>ring-number</i></code>	Creates a pseudo-ring to terminate the RIF and assigns it to a VLAN.
Step 2	<code>multiring {<i>protocol-keyword</i> [all-routes   spanning   all   other]}</code>	Enables collection and use of RIF information with routed protocols.

## Configuring IPX Routing

The IPX Routing support for Token Ring VLANs extends Novell NetWare routing capabilities to include support for routing IPX on Token Ring VLAN interfaces, as well as Ethernet VLAN interfaces. IPX can be routed between:

- TrBRF VLANs
- TrBRFs and the VIP2
- TrBRFs and Ethernet VLANs

Users with Novell NetWare environments can configure either SAP or SNAP encapsulations to be routed across VLAN boundaries.

To configure Cisco IOS software to route IPX on an RSM with connected Token Ring VLANs, use the following commands, beginning in global configuration mode:

	Command	Purpose
Step 1	<code>ipx routing [<i>node</i>]</code>	Enables IPX routing globally.
Step 2	<code>interface vlan <i>vlanid</i> type [trbrf   ethernet]</code>	Configures a Token Ring or Ethernet interface on the RSM.
Step 3	<code>ipx encapsulation <i>encapsulation type</i></code>	Specifies the IPX encapsulation.
Step 4	<code>ipx network <i>network number</i></code>	Specifies the IPX network.



### Note

The default IPX encapsulation format for Token Ring in the Cisco IOS software is SAP. Therefore, you only need to explicitly configure the IPX encapsulation type if your Token Ring network requires SNAP encapsulation instead of SAP.

When routing source-routed traffic for specific VLANs, use the following additional commands in interface configuration mode:

	Command	Purpose
Step 1	<code>multiring trcrf-vlan <i>vlanid</i> ring <i>ring-number</i></code>	Creates a pseudo-ring to terminate the RIF and assigns it to a VLAN.
Step 2	<code>multiring {<i>protocol-keyword</i> [<i>all-routes</i>   <i>spanning</i>   <i>all</i>   <i>other</i>] }</code>	Enables collection and use of RIF information with routed protocols.

## Configuring Source-Route Bridging

To configure SRB on the RSM, use the following commands beginning in global configuration mode:

	Command	Purpose
Step 1	<code>source-bridge ring-group <i>vring-num</i></code>	Configures a virtual ring for the RSM.
Step 2	<code>interface vlan <i>vlanid</i> type [<i>trbrf</i>   <i>ethernet</i>]</code>	Configures a Token Ring or Ethernet interface on the RSM.
Step 3	<code>source-bridge trcrf-vlan <i>vlanid</i> ring-group <i>ring-number</i></code>	Attaches a TrCRF VLAN identifier to the RSM's virtual ring.

## Configuring Source-Route Transparent Bridging

To configure SRT on the RSM, use the following command beginning in global configuration mode:

	Command	Purpose
Step 1	<code>interface vlan <i>vlanid</i> type [<i>trbrf</i>   <i>ethernet</i>]</code>	Configures a Token Ring or Ethernet interface on the RSM.
Step 2	<code>bridge-group <i>bridge-group number</i></code>	Specifies the bridge group to which the interface belongs.

## Configuring Source-Route Translational Bridging

To configure SR/TLB on the RSM, use the following commands beginning in global configuration mode:

	Command	Purpose
Step 1	<code>source-bridge ring-group <i>vring-num</i></code>	Configures a virtual ring for the RSM.
Step 2	<code>source-bridge transparent ring-group <i>pseudo-ring</i> <i>bridge-number</i> <i>tb-group</i> [<i>oui</i>]</code>	Enables bridging between transparent bridging and source-route bridging.
Step 3	<code>interface vlan <i>vlanid</i> type [<i>trbrf</i>   <i>ethernet</i>]</code>	Configures a Token Ring or Ethernet interface on the RSM.
Step 4	<code>source-bridge trcrf-vlan <i>vlanid</i> ring-group <i>ring-number</i></code>	Assigns a VLAN ID to the RSM's virtual ring.

**Note**

For a complete description of SR/TLB, including configuring translation compatibility with IBM 8209 bridges and configuring Token Ring LLC2 to Ethernet Type II (0x80d5) and Token Ring LLC2 to Ethernet 802.3 LLC2 (standard) translations, refer to the “Configuring Source-Route Bridging” chapter in this publication and the “Source-Route Bridging Commands” chapter in the *Cisco IOS Bridging and IBM Networking Command Reference, Volume I*.

## Configuring Automatic Spanning Tree

The automatic spanning-tree function supports automatic resolution of spanning trees in SRB networks, which provides a single path for spanning explorer frames to traverse from a given node in the network to another. Spanning explorer frames have a single-route broadcast indicator set in the RIF. Port identifiers consist of ring numbers and bridge numbers associated with the ports. The spanning-tree algorithm for SRB does not support Topology Change Notification Bridge Protocol Data Unit (BPDU).

Although the automatic spanning-tree function can be configured with SR/TLB, the SRB domain and transparent bridging domain have separate spanning trees. Each Token Ring interface can belong to only one spanning tree. Only one bridge group can run the automatic spanning-tree function at a time.

To create a bridge group that runs an automatic spanning-tree function compatible with the IBM SRB spanning-tree implementation, use the following command in global configuration mode:

Command	Purpose
<code>bridge bridge-group protocol ibm</code>	Creates a bridge group that runs the automatic spanning-tree function.

To enable the automatic spanning-tree function for a specified group of bridged interfaces in SRB or SR/TLB, use the following command in interface configuration mode:

Command	Purpose
<code>source-bridge spanning bridge-group</code>	Enables the automatic spanning-tree function on a group of bridged interfaces.

## Verifying TRRSM

To verify that Token Ring Route Switch Module (TRRSM) is configured, use the following command in privileged EXEC mode:

Command	Purpose
<code>show running configuration</code>	Displays the running configuration of a device.

The following output indicates this is a Token Ring VLAN because of the trbrf interface:

```
milan# show run
version 12.0
!
hostname Sample
!
interface Vlan61 type trbrf
no ip address
```

```
no ip directed-broadcast
no ip route-cache
ethernet-transit-oui 90-compatible
```

To verify the status of the Token Ring VLAN, use either of the following commands in privileged EXEC mode:

Command	Purpose
<code>show ip interfaces brief</code>	Lists a summary of an interface's IP information and status
<code>show interface</code>	Displays statistics for all interfaces configured on the router or access server

The following output indicates that vlan5 and vlan61 interfaces are up:

```
RSM-A# show ip interface brief
Interface IP-Address OK? Method Status Protocol

Vlan5      unassigned YES  unset   up       up
Vlan61     unassigned YES  NVRAM  up       up
```

The following output shows the statistics for vlan61:

```
RSM-A# show interface vlan61
Vlan61 is up, line protocol is up
  Hardware is Cat5k Virtual Token Ring, address is 0009.d49e.0100 (bia
0009.d49e.0100)
  MTU 4464 bytes, BW 16000 Kbit, DLY 630 usec,
    reliability 255/255, txload 1/255, rxload 1/255
  Encapsulation SNAP, loopback not set
  ARP type:SNAP, ARP Timeout 04:00:00
  Ring speed:16 Mbps
  Duplex:half
  Mode:Classic token ring station
```

## Monitoring Statistics

You can collect, clear, and display statistical information about the network.

The Duplicate Ring Protocol (DRiP) runs on Cisco routers and switches that support switched VLAN networking and is used to identify active Token Ring VLANs (TrCRFs).

DRiP maintains the status of TrCRFs and uses this information to determine whether there are multiple TrCRFs active in a TrBRF.

DRiP information is used for the following:

- All-routes explorer filtering

DRiP information is used in conjunction with the local configuration to determine which of the TrCRFs configured within a TrBRF have active ports. This information is used on the base switch to correctly filter all-routes explorers and on the RSM to discard AREs that have already been on an attached ring.

- Detecting the configuration of duplicate TrCRFs across routers and switches

DRiP information is used in conjunction with the local configuration information to determine which TrCRFs are already active on the switches. If a TrCRF is enabled on more than one switch or router, the ports associated with the TrCRF are disabled on all switches. The RSM will not disable the internal ring used for processing source-routed traffic. Instead, the RSM generates the following error message to indicate that two identical TrCRFs exist:

```
DRIP conflict with CRF <vlan-id>
```

To show or clear DRiP or VLAN statistics, use one or all of the following commands in privileged EXEC mode:

Command	Purpose
<code>clear drip counters</code>	Clears DRiP counters.
<code>show drip</code>	Displays DRiP information.



**Note**

When DRiP counters are cleared, the counter is reset to 0. Incrementing of DRiP counters indicates that the router is receiving packets across the TrBRF.

## Configuration Examples

The following sections provide RSM and Catalyst 5000 switch configuration examples:

- IP Routing Source-Routed Frames between a TrBRF VLAN and a VIP2 Token Ring Interface Example, page 184
- IP Routing Source-Routed Frames between a TrBRF VLAN and a VIP2 Ethernet Interface Example, page 185
- IP Routing Source-Routed Frames between TrBRF VLANs Example, page 186
- IP Routing Source-Routed Frames between a TrBRF VLAN and an Ethernet VLAN Example, page 187
- IP Routing Non-Source-Routed Frames between a TrBRF VLAN and a VIP2 Token Ring Interface Example, page 188
- IP Routing Non-Source-Routed Frames between a TrBRF VLAN and a VIP2 Ethernet Interface Example, page 189
- IP Routing Non-Source-Routed Frames between TrBRF VLANs, page 191
- IP Routing Non-Source-Routed Frames between a TrBRF VLAN and an Ethernet VLAN Example, page 192
- SRB Between a TrBRF VLAN and VIP2 Token Ring Interface Example, page 193



```

set tokenring reduction enable
set tokenring distrib-crf disable
#vlangs
set vlan 998 type trbrf bridge 0xd stp ibm
set vlan 200 type trcrf parent 998 ring 0x64 mode srb
set vlan 201 type trcrf parent 998 ring 0x65 mode srb
#add token port to trcrf 201
set vlan 201 5/1

```

Because the VLANs are defined on a per-port basis, endstations connected to ports that belong to the same VLAN should belong to the same IP subnetwork.

## IP Routing Source-Routed Frames between a TrBRF VLAN and a VIP2 Ethernet Interface Example

Following is the configuration for the RSM as shown in Figure 72:

```

interface Ethernet 2/2
 ip address 4.4.4.1 255.255.255.0
!
interface vlan998 type trbrf
 ip address 5.5.5.1 255.255.255.0
 multiring trcrf-vlan 200 ring 100
 multiring all

```

**Figure 72** IP Routing Source-Routed Frames between a TrBRF VLAN and a VIP2 Ethernet Interface

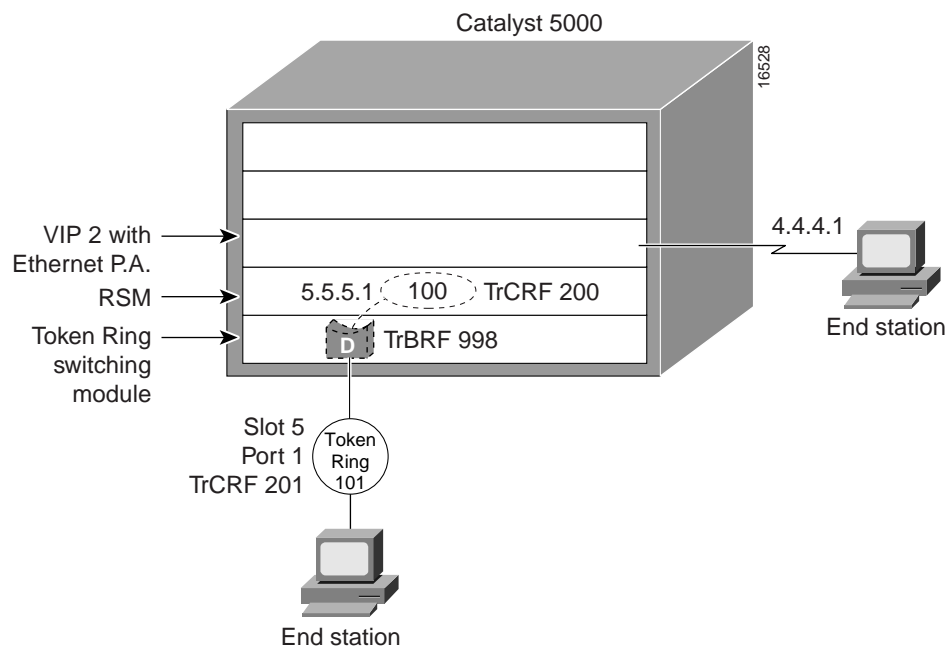

The following is the configuration for the Catalyst 5000 switch with an Ethernet module in slot 2 and a Token Ring switch module in slot 5. In this configuration, the Token Ring port 5/1 is assigned with TrCRF VLAN 201.

```

#vtp
set vtp domain trrsm
set vtp mode server
set vtp v2 enable

```

```
#drip
set tokenring reduction enable
set tokenring distrib-crf disable
#vlans
set vlan 998 type trbrf bridge 0xd stp ibm
set vlan 200 type trcrf parent 998 ring 0x64 mode srb
set vlan 201 type trcrf parent 998 ring 0x65 mode srb
#add token ring port to trcrf 201
set vlan 201 5/1
```

Because the VLANs are defined on a per-port basis, endstations connected to ports that belong to the same VLAN should belong to the same IP subnetwork.

## IP Routing Source-Routed Frames between TrBRF VLANs Example

Following is the configuration for the RSM as shown in Figure 73:

```
interface vlan998 type trbrf
ip address 5.5.5.1 255.255.255.0
multiring trcrf-vlan 200 ring 100
multiring all
interface vlan999 type trbrf
ip address 6.6.6.1 255.255.255.0
multiring trcrf-vlan 201 ring 101
multiring all
```

**Figure 73** IP Routing Source-Routed Frames between TrBRF VLANs

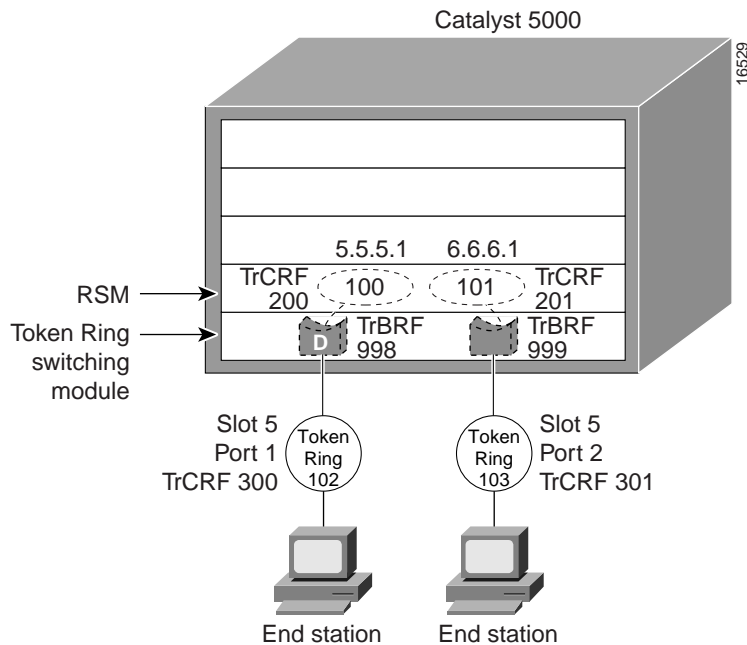

The following is the configuration for the Catalyst 5000 switch with an Ethernet module in slot 2 and a Token Ring switch module in slot 5. In this configuration, the Token Ring port 5/1 is assigned with TrCRF VLAN 300 and the Token Ring port 5/2 is assigned with TrCRF VLAN 301.

```
#vtp
set vtp domain trrsm
set vtp mode server
```

```

set vtp v2 enable
#drip
set tokenring reduction enable
set tokenring distrib-crf disable
#vlans
set vlan 998 type trbrf bridge 0xd stp ibm
set vlan 200 type trcrf parent 998 ring 0x64 mode srb
set vlan 300 type trcrf parent 998 ring 0x66 mode srb
set vlan 999 type trbrf bridge 0xe stp ibm
set vlan 201 type trcrf parent 999 ring 0x65 mode srb
set vlan 301 type trcrf parent 999 ring 0x67 mode srb
#add token port to trcrfs
set vlan 300 5/1
set vlan 301 5/2

```

Because the VLANs are defined on a per-port basis, endstations connected to ports that belong to the same VLAN should belong to the same IP subnetwork.

## IP Routing Source-Routed Frames between a TrBRF VLAN and an Ethernet VLAN Example

Following is the configuration for the RSM as shown in Figure 74:

```

interface vlan998 type trbrf
 ip address 5.5.5.1 255.255.255.0
 multiring trcrf-vlan 200 ring 100
 multiring all
interface vlan500 type ethernet
 ip address 6.6.6.1 255.255.255.0

```

**Figure 74** IP Routing Source-Routed Frames between a TrBRF VLAN and an Ethernet VLAN

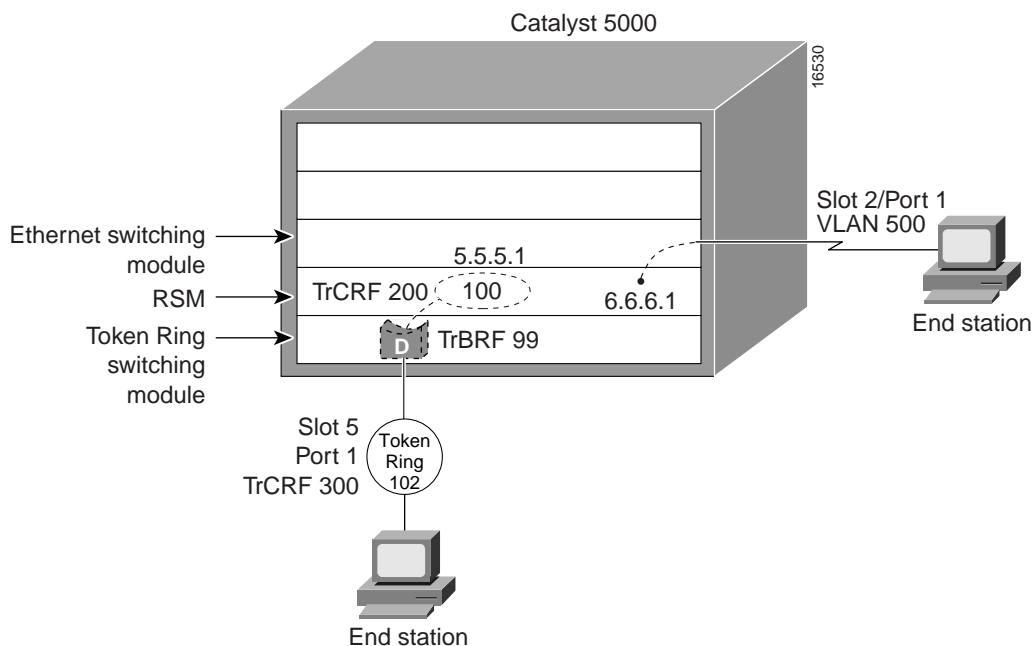

The following is the configuration for the Catalyst 5000 switch with an Ethernet module in slot 2 and a Token Ring switch module in slot 5. In this configuration, the Token Ring port 5/1 is assigned with TrCRF VLAN 300 and the Ethernet port 2/1 is assigned with VLAN 500.

```
#vtp
set vtp domain trrsm
set vtp mode server
set vtp v2 enable
#drip
set tokenring reduction enable
set tokenring distrib-crf disable
#vlans
set vlan 998 type trbrf bridge 0xd stp ibm
set vlan 200 type trcrf parent 998 ring 0x64 mode srb
set vlan 300 type trcrf parent 998 ring 0x66 mode srb
#add token port to trcrf 300
set vlan 300 5/1
#add ether port to 500
set vlan 500 2/1
```

Because the VLANs are defined on a per-port basis, endstations connected to ports that belong to the same VLAN should belong to the same IP subnetwork.

## IP Routing Non-Source-Routed Frames between a TrBRF VLAN and a VIP2 Token Ring Interface Example

Following is the configuration for the RSM as shown in Figure 75:

```
interface TokenRing 3/1
 ip address 4.4.4.1 255.255.255.0
!
interface vlan998 type trbrf
 ip address 5.5.5.1 255.255.255.0
```



### Note

---

The **multiring** command is not needed in this configuration since these are non-source-routed frames.

---

**Figure 75** IP Routing Non-Source-Routed Frames between a TrBRF VLAN and a VIP2 Token Ring Interface

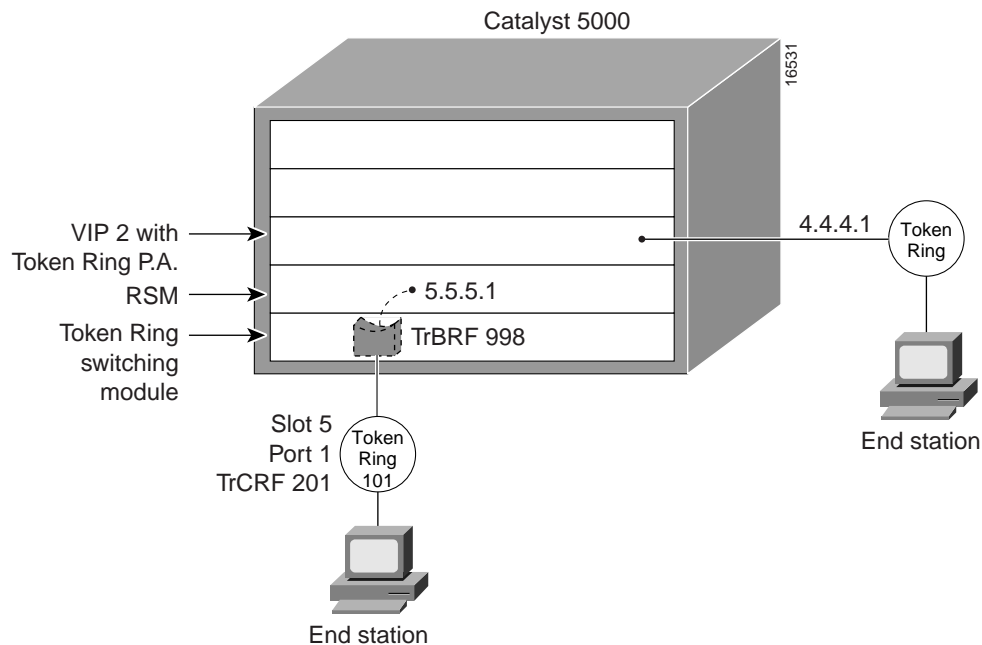

The following is the configuration for the Catalyst 5000 switch with an Ethernet module in slot 2 and a Token Ring switch module in slot 5. In this configuration, the Token Ring port 5/1 is assigned with the TrCRF VLAN 201.

```
#vtp
set vtp domain trrsm
set vtp mode server
set vtp v2 enable
#drip
set tokenring reduction enable
set tokenring distrib-crf disable
#vlans
set vlan 998 type trbrf bridge 0xd stp ieee
set vlan 201 type trcrf parent 998 ring 0x65 mode srt
#add token port to trcrf 201
set vlan 201 5/1
```

Because the VLANs are defined on a per-port basis, endstations connected to ports that belong to the same VLAN should belong to the same IP subnetwork.

## IP Routing Non-Source-Routed Frames between a TrBRF VLAN and a VIP2 Ethernet Interface Example

Following is the configuration for the RSM as shown in Figure 76:

```
interface Ethernet 2/2
ip address 4.4.4.1 255.255.255.0
!
interface vlan998 type trbrf
ip address 5.5.5.1 255.255.255.0
```

**Note**

The **multiring** command is not needed in this configuration because these are non-source-routed frames.

**Figure 76** IP Routing Non-Source-Routed Frames between a TrBRF VLAN and a VIP2 Ethernet Interface

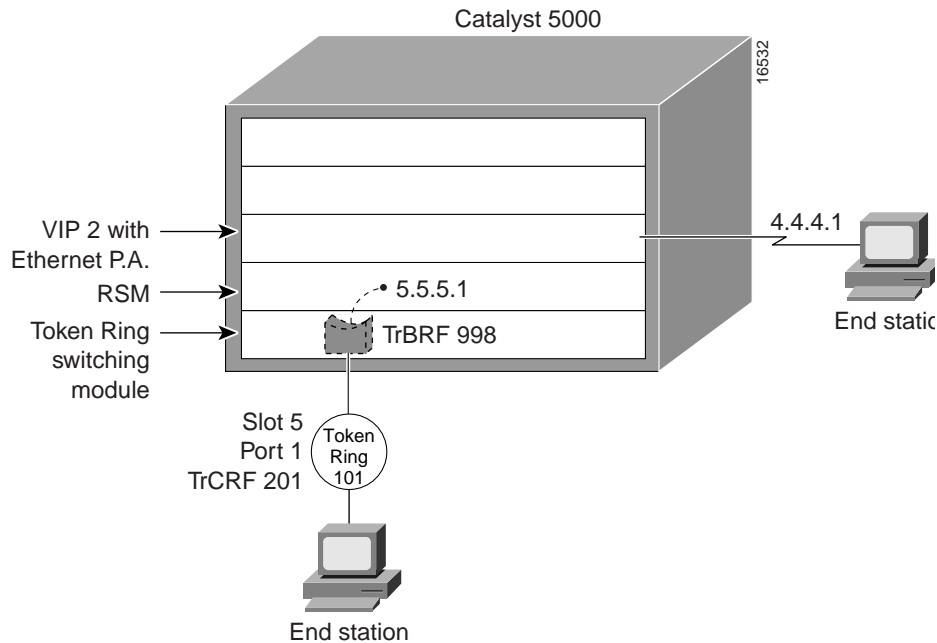

The following is the configuration for the Catalyst 5000 switch with an Ethernet module in slot 2 and a Token Ring switch module in slot 5. In this configuration, the Token Ring port 5/1 is assigned with TrCRF VLAN 201.

```
#vtp
set vtp domain trrsm
set vtp mode server
set vtp v2 enable
#drip
set tokenring reduction enable
set tokenring distrib-crf disable
#vlans
set vlan 998 type trbrf bridge 0xd stp ieee
set vlan 201 type trcrf parent 998 ring 0x65 mode srt
#add token ring port to trcrf 201
set vlan 201 5/1
```

Because the VLANs are defined on a per-port basis, endstations connected to ports that belong to the same VLAN should belong to the same IP subnetwork.

## IP Routing Non-Source-Routed Frames between TrBRF VLANs

Following is the configuration for the RSM as shown in Figure 77:

```
interface vlan998 type trbrf
 ip address 5.5.5.1 255.255.255.0
interface vlan999 type trbrf
 ip address 6.6.6.1 255.255.255.0
```



**Note**

The **multiring** command is not needed in this configuration because these are non-source-routed frames.

**Figure 77** IP Routing Non-Source-Routed Frames between TrBRF VLANs

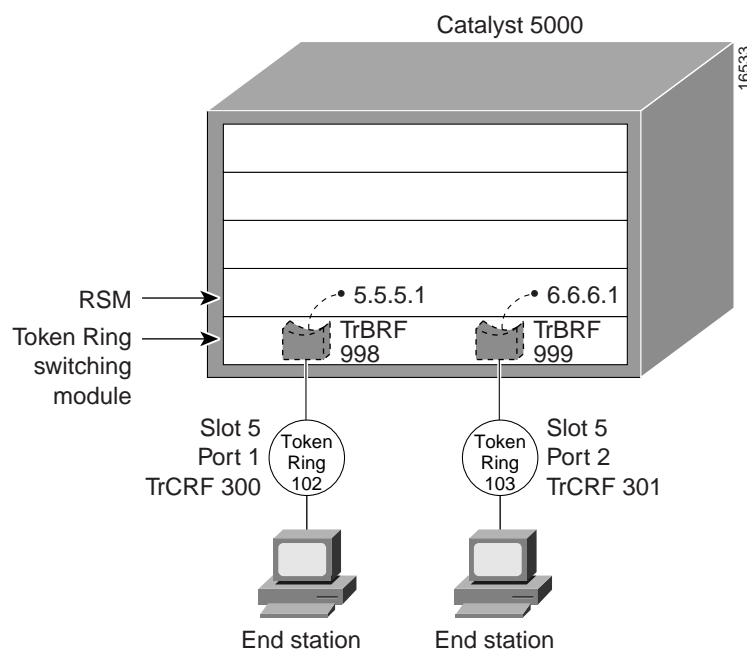

The following is the configuration for the Catalyst 5000 switch with an Ethernet module in slot 2 and a Token Ring switch module in slot 5. In this configuration, the Token Ring port 5/1 is assigned with VLAN 300 and the Token Ring port 5/2 is assigned with VLAN 301.

```
#vtp
set vtp domain trrsm
set vtp mode server
set vtp v2 enable
#drip
set tokenring reduction enable
set tokenring distrib-crf disable
#vlans
set vlan 998 type trbrf bridge 0xd stp ieee
set vlan 300 type trcrf parent 998 ring 0x66 mode srt
set vlan 999 type trbrf bridge 0xd stp ieee
set vlan 301 type trcrf parent 999 ring 0x67 mode srt
#add token port to trcrfs
set vlan 300 5/1
set vlan 301 5/2
```

Because the VLANs are defined on a per-port basis, endstations connected to ports that belong to the same VLAN should belong to the same IP subnetwork.

## IP Routing Non-Source-Routed Frames between a TrBRF VLAN and an Ethernet VLAN Example

Following is the configuration for the RSM as shown in Figure 78:

```
interface vlan998 type trbrf
 ip address 5.5.5.1 255.255.255.0
!
interface vlan500 type ethernet
 ip address 6.6.6.1 255.255.255.0
```



### Note

The **multiring** command is not needed in this configuration since these are non-source-routed frames.

**Figure 78** IP Routing Non-Source-Routed Frames between a TrBRF VLAN and an Ethernet VLAN

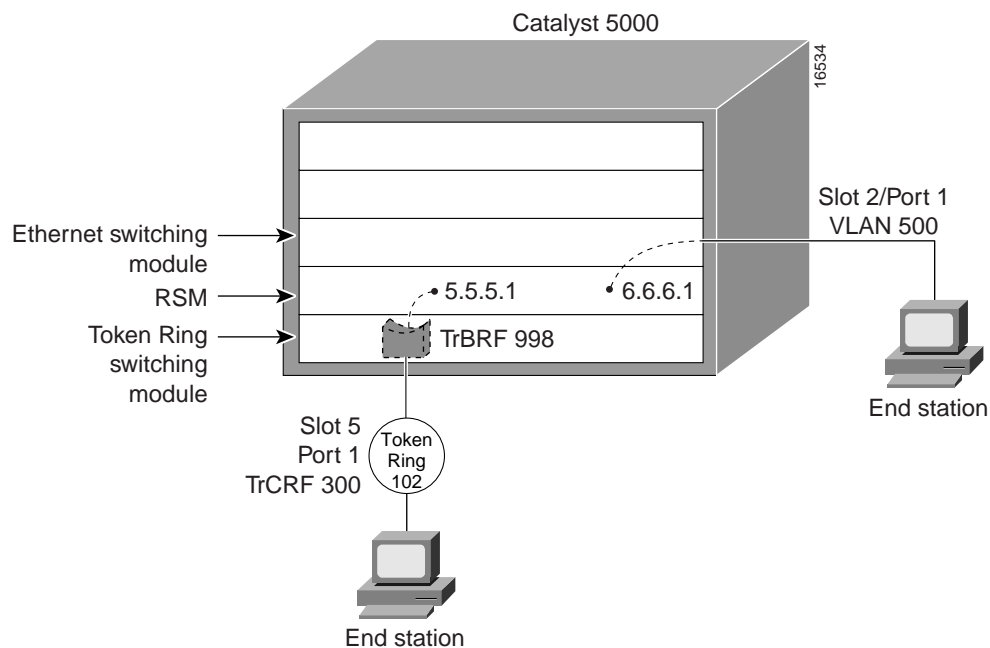

The following is the configuration for the Catalyst 5000 switch with an Ethernet module in slot 2 and a Token Ring switch module in slot 5. In this configuration, the Token Ring port 5/1 is assigned with TrCRF VLAN 300 and the Ethernet port 2/1 is assigned with VLAN 500.

```
#vtp
set vtp domain trrsm
set vtp mode server
set vtp v2 enable
#drip
set tokenring reduction enable
set tokenring distrib-crf disable
#vlans
set vlan 998 type trbrf bridge 0xd stp ieee
set vlan 300 type trcrf parent 998 ring 0x66 mode srt
```

```
#add token port to trcrf 300
set vlan 300 5/1
#add ether port to 500
set vlan 500 2/1
```

Because the VLANs are defined on a per-port basis, endstations connected to ports that belong to the same VLAN should belong to the same IP subnetwork.

## SRB Between a TrBRF VLAN and VIP2 Token Ring Interface Example

The following configuration refers to the RSM as shown in Figure 79:

```
interface TokenRing3/1
  source-bridge 10 1 100
  source-bridge spanning
!
source-bridge ring-group 100
interface vlan999 type trbrf
  source-bridge trcrf-vlan 40 ring-group 100
  source-bridge spanning
```

**Figure 79** SRB Between a TrBRF VLAN and VIP2 Token Ring Interface

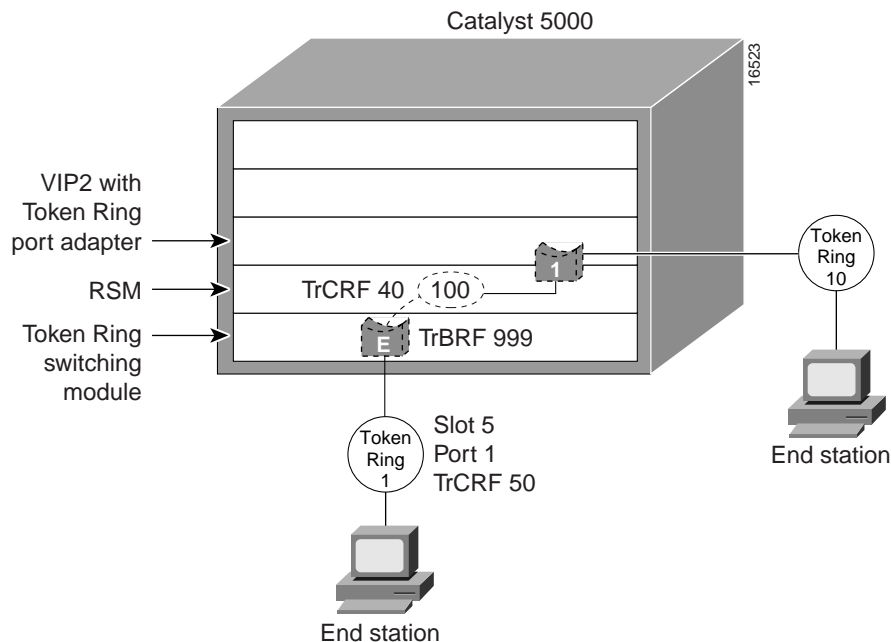

Following is the configuration for the Catalyst 5000 switch which performs simple SRB. In this configuration, the Token Ring switch module exists in slot 5 and is using port 1. The Token Ring port on 5/1 is assigned to TrCRF VLAN 50.

```
#vtp
set vtp domain trrsm
set vtp mode server
set vtp v2 enable
#drip
set tokenring reduction enable
set tokenring distrib-crf disable
```

```
#vlangs
set vlan 999 name trbrf type trbrf bridge 0xe stp ibm
set vlan 40 name trcrf40 type trcrf parent 999 ring 0x64 mode srb
set vlan 50 name trcrf50 type trcrf parent 999 ring 0x1 mode srb
#add token port to trcrf 50
set vlan 50 5/1
```

In this configuration, the keyword **name** is optional and **srb** is the default mode. The ring number on the switch must be specified in decimal by substituting the **decring** keyword for ring.

## SRB Between TrBRF VLANs Example

The following configuration refers to the RSM as shown in Figure 80:

```
source-bridge ring-group 100
!
interface vlan999 type trbrf
 source-bridge trcrf-vlan 40 ring-group 100
 source-bridge spanning
!
interface vlan998 type trbrf
 source-bridge trcrf-vlan 70 ring-group 100
 source-bridge spanning
```

**Figure 80** SRB Between TrBRF VLANs

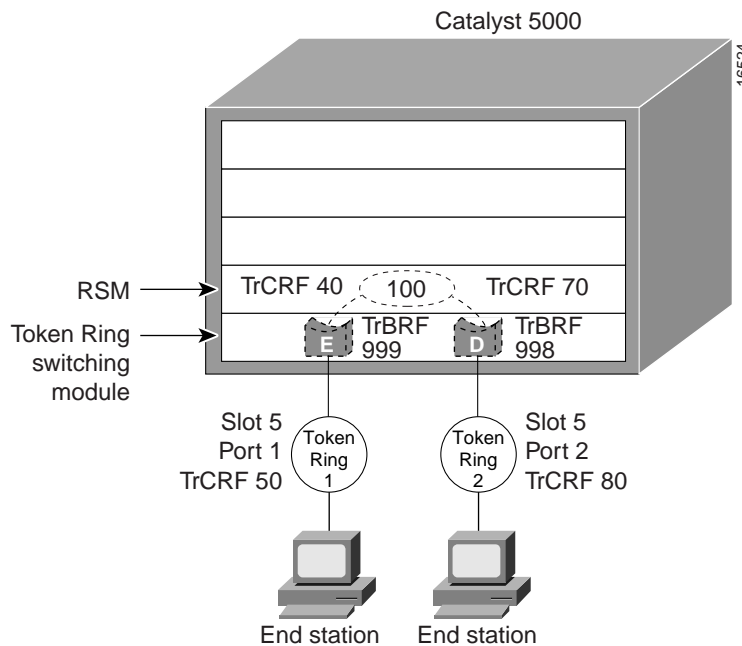

The following is the configuration for the Catalyst 5000 switch with the Token Ring switch module in slot 5. The Token Ring port on 5/1 is assigned to TrCRF VLAN 50 and the Token Ring port on 5/2 is assigned to TrCRF VLAN 80.

```
#vtp
set vtp domain trrsm
set vtp mode server
set vtp v2 enable
```

```

#drip
set tokenring reduction enable
set tokenring distrib-crf disable
#vlans
set vlan 999 name trbrf type trbrf bridge 0xe stp ibm
set vlan 40 name trcrf40 type trcrf parent 999 ring 0x64 mode srb
set vlan 50 name trcrf50 type trcrf parent 999 ring 0x1 mode srb
set vlan 998 name trbrf type trbrf bridge 0xd stp ibm
set vlan 70 name trcrf70 type trcrf parent 998 ring 0x64 mode srb
set vlan 80 name trcrf80 type trcrf parent 998 ring 0x2 mode srb
#add token port to trcrf 50
set vlan 50 5/1
#add token port to trcrf 80
set vlan 80 5/2

```

In this configuration, the keyword *name* is optional and *srb* is the default mode.

## Transparent Bridging between a TrBRF VLAN and a VIP2 Token Ring Interface Example

The following is the configuration for the RSM as shown in Figure 81:

```

bridge 1 protocol ieee
!
interface tokenring0
 bridge-group 1
interface vlan 50 type trbrf
 bridge-group 1

```

**Figure 81** Transparent Bridging between a TrBRF VLAN and a VIP2 Token Ring Interface

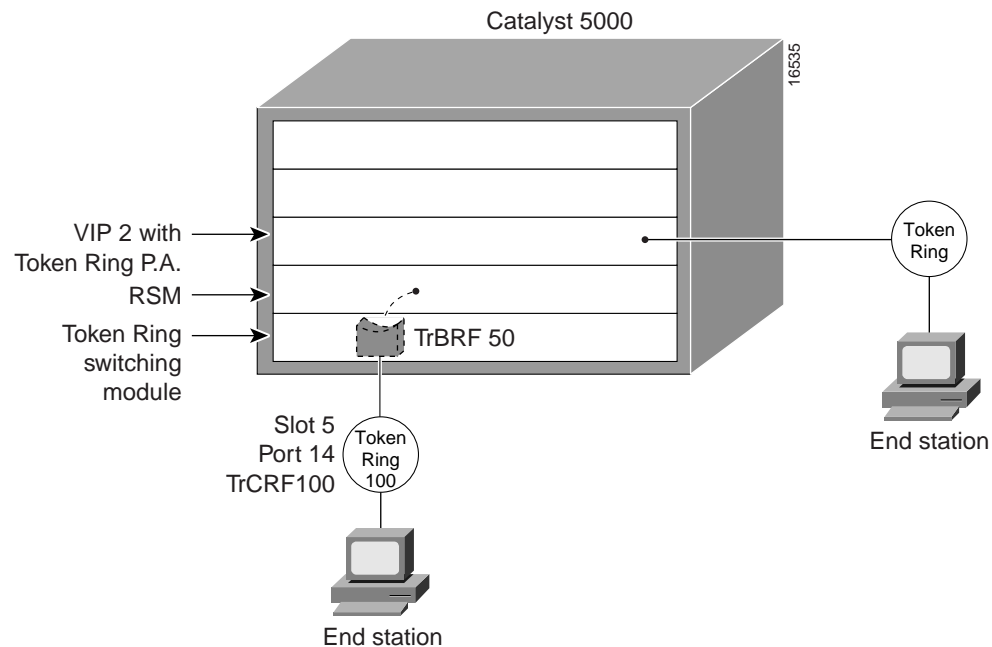

The following is the configuration for the Catalyst 5000 switch with a Token Ring switch module in slot 5:

```
#vtp
set vtp domain trrsm
set vtp mode server
set vtp v2 enable
#drip
set tokenring reduction enable
set tokenring distrib-crf disable
#vlans
set vlan 50 name trbrf50 type trbrf bridge 0xb stp ieee
set vlan 100 name trcrf100 type trcrf ring 0x64 parent 50 mode srt
#add token port to trcrf 100
set vlan 100 5/14
```

## SR/TLB between a TrBRF VLAN and a VIP2 Ethernet Interface Example

The following is the configuration for the RSM as shown in Figure 82:

```
source-bridge ring-group 100
bridge 1 protocol ieee
source-bridge transparent 100 200 10 1
!
interface vlan999 type trbrf
source-bridge trcrf-vlan 20 ring-group 100
source-bridge spanning
!
interface ethernet1/0
bridge-group 1
```

**Figure 82** SR/TLB between a TrBRF VLAN and a VIP2 Ethernet Interface

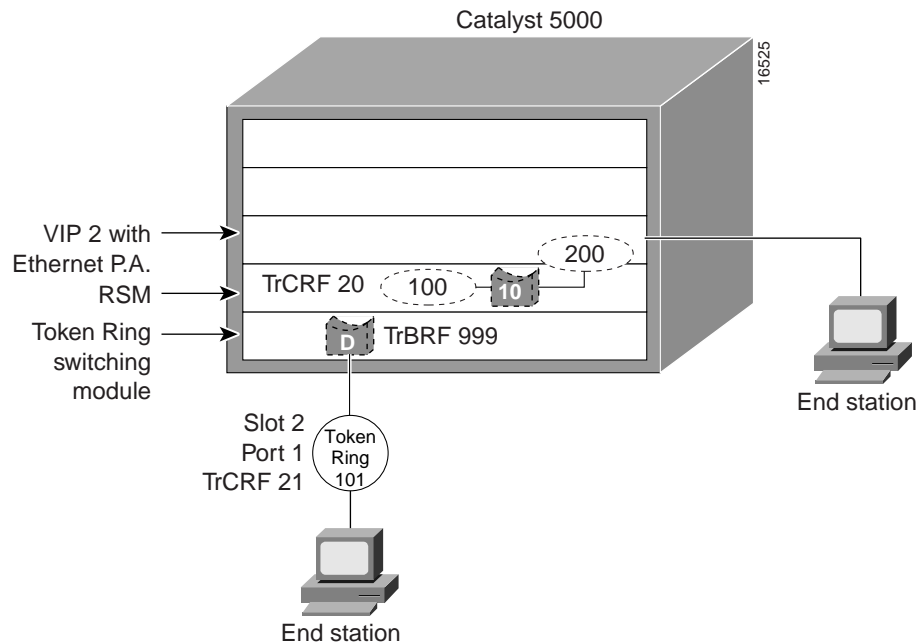

The following is the configuration for the Catalyst 5000 switch with an Ethernet module in slot 2 and a Token Ring switch module in slot 5. In this configuration, the Token Ring port on 2/1 is assigned to VLAN 21.

```
#vtp
set vtp domain trrsm
set vtp mode server
set vtp v2 enable
#drip
set tokenring reduction enable
set tokenring distrib-crf disable
#vlans
set vlan 999 type trbrf bridge 0xd stp ibm
set vlan 20 type trcrf parent 999 ring 0x64 mode srb
set vlan 21 type trcrf parent 999 ring 0x65 mode srb
#add token ring port to trcrf 21
set vlan 21 2/1
```

## SR/TLB between a TrBRF VLAN and Ethernet VLAN Example

The following is the configuration for the RSM as shown in Figure 83:

```
source-bridge ring-group 100
bridge 1 protocol ieee
source-bridge transparent 100 200 10 1
!
interface vlan999 type trbrf
source-bridge trcrf-vlan 20 ring-group 100
source-bridge spanning
!
interface vlan100 type ethernet
bridge-group 1
```

**Figure 83 SR/TLB between a TrBRF VLAN and Ethernet VLAN**

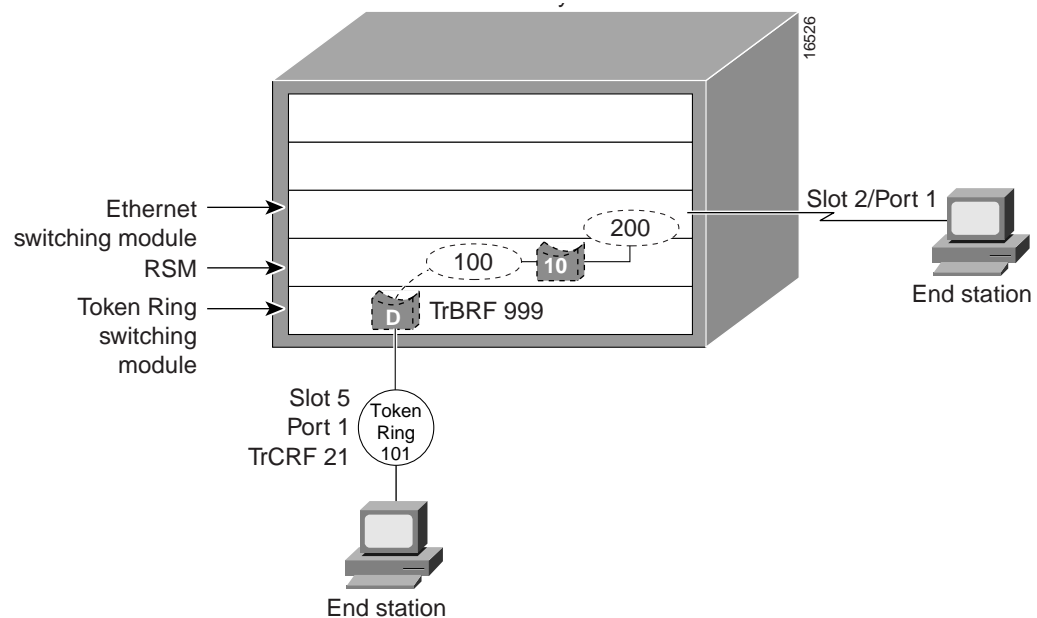

The following is the configuration for the Catalyst 5000 switch with an Ethernet module in slot 2 and a Token Ring switch module in slot 5. In this configuration, the Token Ring port on 5/1 is assigned to TrCRF 21, and the Ethernet port on 2/1 is assigned to VLAN 100.

```
#vtp
set vtp domain trrsm
set vtp mode server
set vtp v2 enable
#drip
set tokenring reduction enable
set tokenring distrib-crf disable
#vlans
set vlan 999 type trbrf bridge 0xd stp ibm
set vlan 20 type trcrf parent 999 ring 0x64 mode srb
set vlan 21 type trcrf parent 999 ring 0x65 mode srb
#add token port to trcrf 21
set vlan 21 5/1
#add ethernet
set vlan 100 type ethernet
set vlan 100 2/1
```

## DLSw+ Example

The following is the configuration for the RSM with a VIP2 serial interface as shown in Figure 84:

```
source-bridge ring-group 100
dlsw local-peer peer-id 10.18.20.8
dlsw remote-peer 0 tcp 10.18.20.6
!
interface Serial1/0
ip address 10.18.20.8 255.255.255.0
no keepalive
clockrate 64000
!
interface Vlan89 type trbrf
no ip address
source-bridge trcrf-vlan 9 ring-group 100
source-bridge spanning
```

Figure 84 Configuration for DLSw+ Example

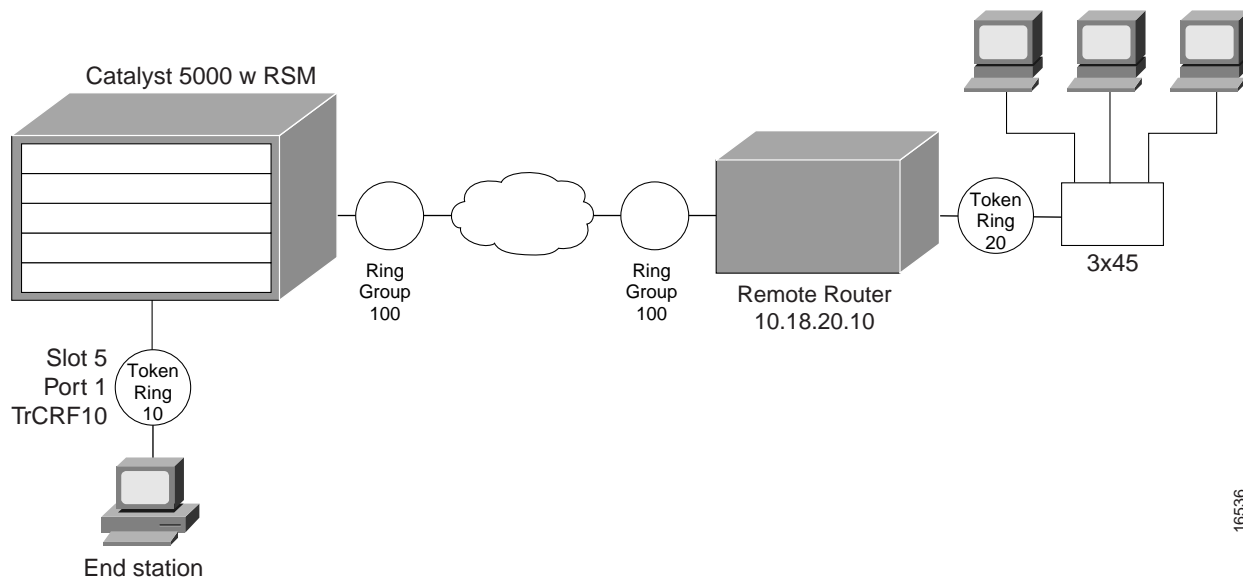

16536

The following is the configuration for a Catalyst 5000 with a Token Ring module in slot 5. In this configuration, the Token Ring port 5/1 is assigned with the TrCRF VLAN 10:

```
#vtp
set vtp domain trrsm
set vtp mode server
set vtp v2 enable
#drip
set tokenring reduction enable
set tokenring distrib-crf disable
#vlans
set vlan 89 type trbrf bridge 0xd stp ibm
set vlan 10 type trcrf parent 89 ring 0xa mode srb
#add token ring port to TrCRF 10
set vlan 10 5/1
set vlan 9 type trcrf parent 89 ring 0x64 mode srb
```

The following is the configuration for the remote router:

```
source-bridge ring group 100
dlsw local-peer peer-id 10.18.20.6
dlsw remote-peer 0 tcp 10.18.20.8
!
interface loopback 0
 ip address 10.18.20.6
!
interface serial1/0
 no ip address
 no keepalive
 clockrate 64000
!
interface tokenring 2/0
 no ip address
 ring-speed 16
 source-bridge 20 1 100
 source-bridge spanning
```

