



Configuring CMPC+

Cisco Multipath Channel+ (CMPC+) is Cisco's implementation of IBM's Multipath Channel+ (MPC+) feature. The CMPC+ feature in Cisco IOS Release 12.0(3)T and later supports the MPC+ features and protocols necessary to support IP. This chapter provides information about configuring CMPC+ support on the Channel Interface Processor (CIP) and Channel Port Adapter (CPA) types of Cisco Mainframe Channel Connection (CMCC) adapters on a Cisco router.

This information is described in the following sections:

- Overview of CMPC+, page 729
- Preparing to Configure CMPC+, page 735
- Configuring CMPC+ Support, page 737
- Monitoring and Maintaining CMPC+, page 760
- Configuration Examples, page 761

For a complete description of the CMPC+ commands in this chapter, refer to the “CSNA, CMPC, and CMPC+ Commands” chapter of the *Cisco IOS Bridging and IBM Networking Command Reference, Volume II*. To locate documentation of other commands that appear in this chapter, use the command reference master index or search online.

Overview of CMPC+

CMPC+ enables High Performance Data Transfer (HPDT). It allows TCP/IP connections to the host through CMCC adapters, using either the TCP/IP stack or the High Speed Access Services (HSAS) IP stack.

CMPC+ offers the following support:

- Support for TCP/IP and HSAS Transmission Group (TG)
- Support for one IP stack per MPC+ group
- Support for one read subchannel and one write subchannel per CMPC+ group. The read subchannel and write subchannel in an MPC+ group can be on different physical channels.
- Support for up to 64 KB per I/O block.
- Supports the CIP and the CPA

Up to 64 MPC+ groups can be configured on a CMCC, depending on memory configuration. CMPC+ can coexist with CMPC, TCP/IP Offload, CLAW, TN3270, and CSNA features.

Figure 278 shows an MVS host with a TCP/IP stack and a Cisco router configured with CMPC+ and IP.

Figure 278 MVS Host with TCP/IP Stack and Cisco Router with CMPC+

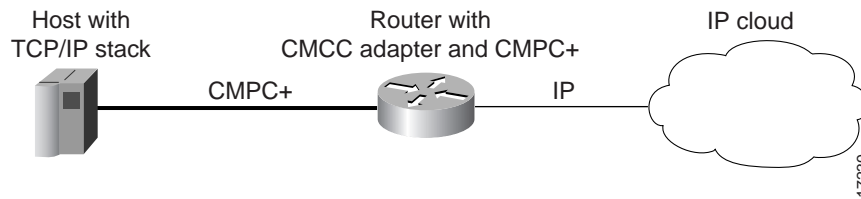
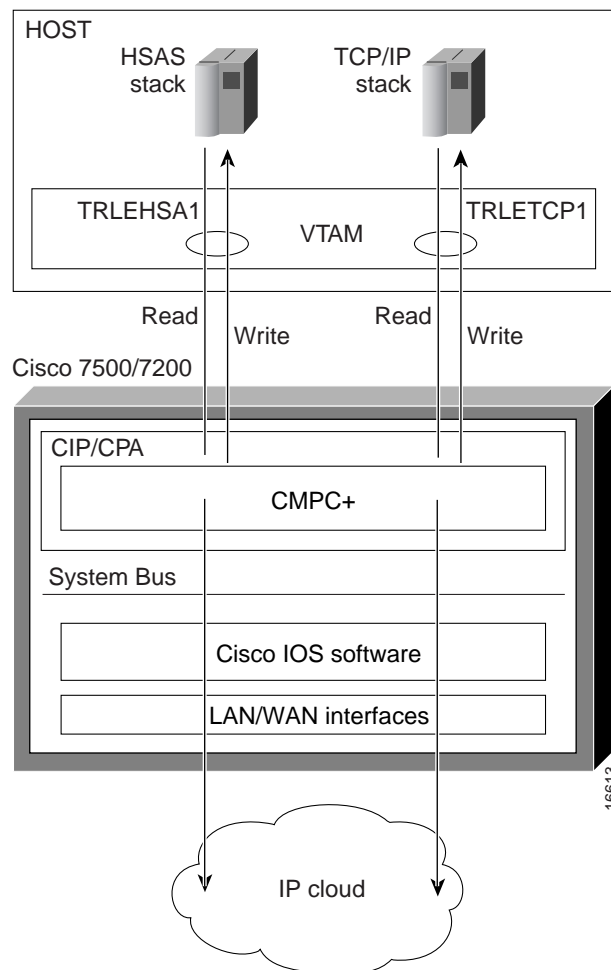

Figure 279 shows a scenario where a VTAM host is configured with both HSAS and TCP/IP stacks. Each stack on the host has a TG with a read and write subchannel. The CMCC adapter can be a CIP or CPA. On the outbound flow coming from the host, the Cisco router receives the MPC+ packets from the channel, removes the MPC+ headers, and transfers the packets as IP packets to the IP cloud. The router sends the packets to the appropriate interface, depending on the destination IP address in the packet.

On the inbound flow coming from the IP cloud via LAN or WAN interfaces, the IP packets are switched from the Cisco IOS software to the CMCC adapter and MPC+ headers are added to the packets. The MPC+ block of packets is then sent to the host.

Figure 279 CMPC+ IP Structure



IP communication from one IBM host to another can also be accomplished through the same CMCC adapter. Figure 280 illustrates IP packets going from Host 1 to Host 2 and from Host 2 to Host 1. These packets are routed through the same Route Switch Processor (RSP) in the Cisco router.

Figure 280 IP Communication Between IBM Hosts Through the Same CMCC

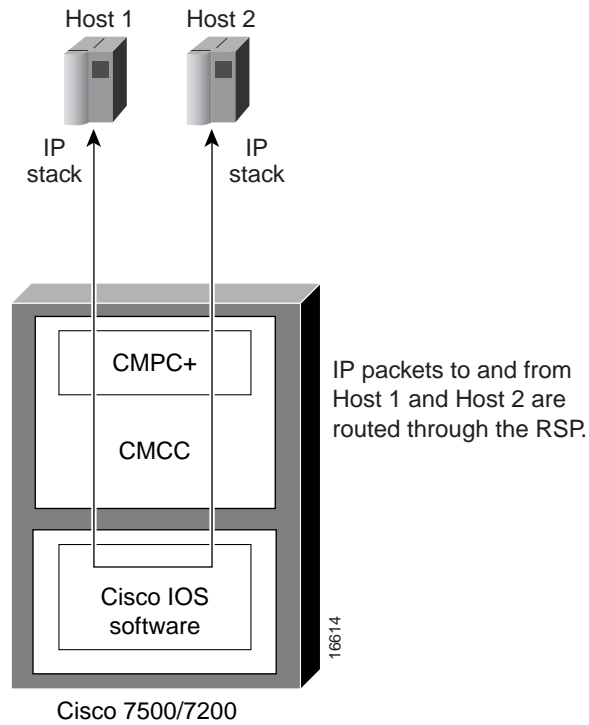

Figure 281 illustrates IP packets flowing between host 1 and host 2. IP packets can also be sent from one host to another host using different CMCC adapters.

Figure 281 IP Communication Between IBM Hosts Using Different CMCC Adapters

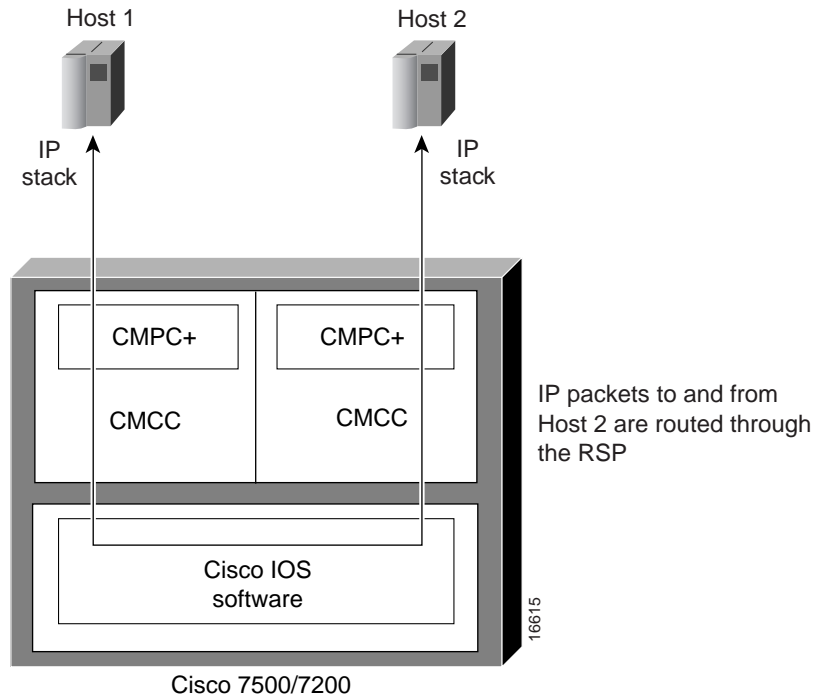

Figure 282 illustrates IP communication flowing between Host 1 and Host 2. IP communication can occur between two different hosts connected through two different routers.

Figure 282 IP Communication Between Hosts Through Different Routers

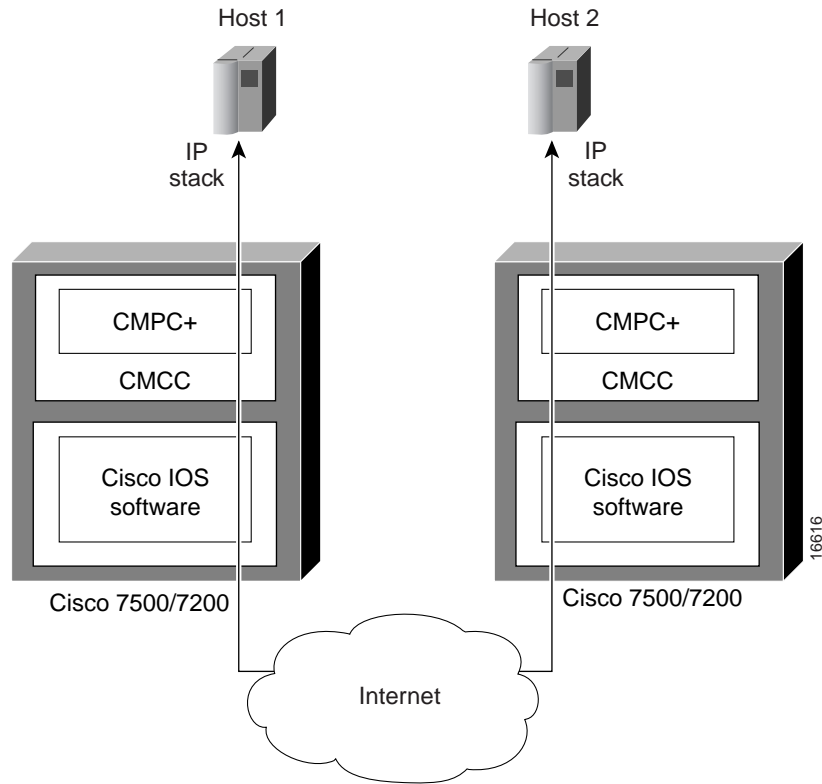
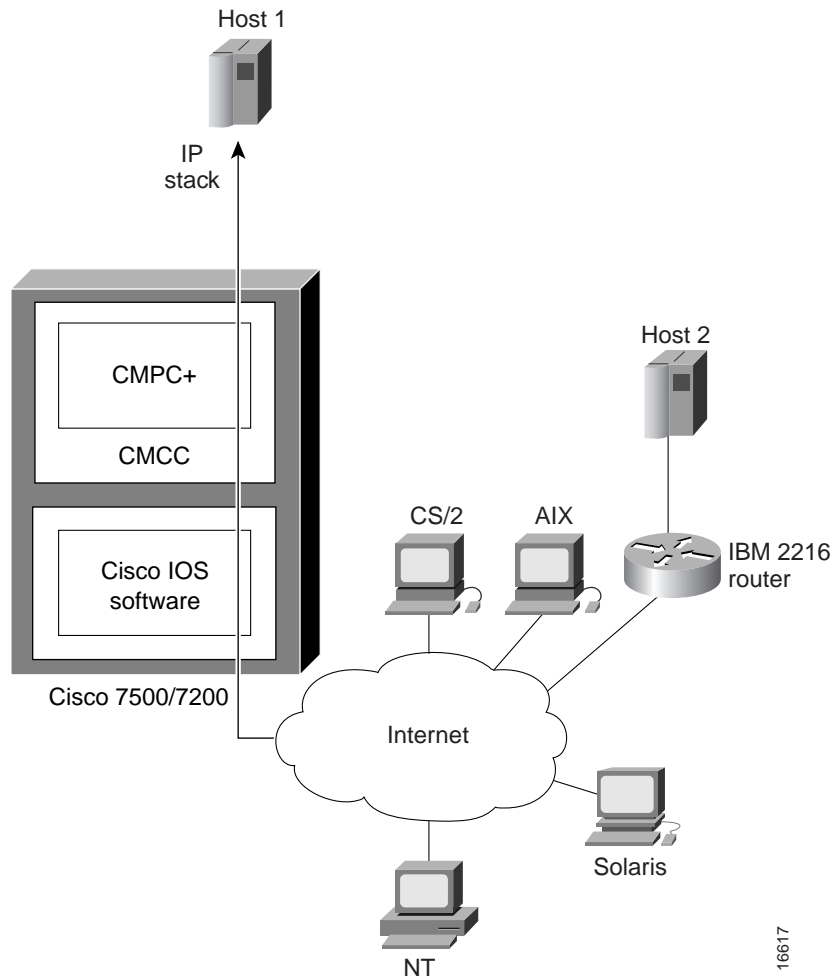

Figure 283 illustrates IP communication between a host and different IP nodes.

Figure 283 IP Communication from a Host to IP Nodes



16617

Benefits of CMPC+

CMPC+ provides the following benefits:

- Support for HPDT
- IP connections to hosts using MPC+
- Coexists with CMPC, CSNA, TN3270, TCP/IP Offload, and CLAW features on a CMCC
- ESCON and Parallel Channel support
- ESCON Director support
- EMIF support

Preparing to Configure CMPC+

The following topics in this section provide information that is useful when you are planning to configure CMPC+ support:

- Hardware and Software Requirements
- Mainframe Host Configuration Considerations

Hardware and Software Requirements

This section provides information about the router and mainframe requirements to support CMPC+.

Router Requirements

The CMPC+ feature is supported on the following router platforms and requires the appropriate CMCC microcode and a minimum of 32 MB DRAM on the CMCC adapter:

- Cisco 7500 series—Supports CIP adapters
- Cisco 7200 series—Supports ECPA and PCPA adapters
- Cisco 7000 series with RSP7000—Supports CIP adapters

You must configure the CMPC+ feature on the physical interface of a CMCC adapter. For a CIP, the physical interface is either 0 or 1. For the CPA adapters, ECPA and PCPA, the physical interface is port 0.

Mainframe Requirements

CMPC+ establishes channel connectivity to a S/390 mainframe host using the Virtual Telecommunications Access Method (VTAM) and IP stacks. The following software versions of S/390, VTAM, and IP stacks are required to configure CMPC+ on a CMCC adapter:

Operating System and VTAM Requirements

- OS/390 1.3 and later
- ACF/VTAM 4.4 and later

IP Stack Requirements

CMPC+ requires one of the following IP stacks on the mainframe:

- TCP/IP 3.3 and later
- HSAS

Mainframe Host Configuration Considerations

Configuring CMPC+ support requires that you perform tasks for configuration of the mainframe and the router sides of the network environment.

Often in the mixed network environment of mainframes and LANs, an MVS systems programmer installs and maintains the mainframe side of the network, while a network engineer manages the routers on the LAN side of the network. In such an environment, the successful configuration of CMPC+ support requires the close coordination between these job functions at a customer site.

This chapter contains information for both the network engineer and the MVS systems programmer to properly configure the network devices for CMPC+ support. The tasks for configuring CMPC+ support are organized by whether they are host-related configuration tasks or router-related configuration tasks. In addition, a topic for correlating the mainframe and router configuration is provided so that you can identify the dependencies between the host and router configuration elements and be sure that they are set up correctly.

Defining the Channel Subsystem for the Router

To establish the path and allocate the range of subchannel addresses that the CMCC adapter can use for the CMPC+ feature, you need to specify the channel subsystem definitions in the Input/Output Control Program (IOCP) or Hardware Configuration Definition (HCD).

For more information about the statements that might be defined in an IOCP file for parallel channels and ESCON channels on the CIP or CPA, see the “Defining the Channel Subsystem for the Router” section in the “Configuring Cisco Mainframe Channel Connection Adapters” chapter of this publication.

Disabling the Missing Interrupt Handler

Because the appropriate configuration of the missing interrupt handler (MIH) varies according to the protocols and software releases used, Cisco offers the following guidance:

- For OS/390 releases Version 2 Release 4 and earlier, set the MIH to zero.
- For OS/390 releases later than Version 2 Release 4 and z/OS releases, refer to the following section of the z/OS Communications Server IP Configuration Reference:
<http://publibfp.boulder.ibm.com/cgi-bin/bookmgr/BOOKS/f1a1b420/1.2.13?SHELF=f1a1bk31&DT=20020604120755#HDRMOLLY>

For information about how to disable the MIH for the unit addresses being used for your CMCC adapter configuration, see the section “Disabling the Missing Interrupt Handler” section in the “Configuring Cisco Mainframe Channel Connection Adapters” chapter of this publication.

Related Publications

The following mainframe-related publications might be useful when configuring the mainframe to support CMPC+ on a CMCC adapter in the router:

- *OS/390 TCP/IP OpenEdition Configuration Guide*, SC31-8304-00
- *OS/390 TCP/IP OpenEdition Planning and Release Guide*, SC31-8303-00
- *OS/390 TCP/IP OpenEdition User's Guide*, GC31-8305-00
- *IP Planning and Migration Guide*, SC31-8512
- *IP User's Guide*, C31-8514-00

- *High Speed Access Services User's Guide*, GC31-8676
- *ES/390 Principles of Operation*, SA22-7201
- *VTAM Network Implementation Guide*, SC31-8370-00
- *VTAM Resource Definition Reference*, SC31-8377-00
- *VTAM V4R4 Resource Definition Samples*, SC31-8378-00

Configuring CMPC+ Support

This section describes the configuration tasks that are required to install CMPC+ support on the mainframe and router and includes the following topics:

- CMPC+ Configuration Guidelines, page 737
- CMPC+ Host Configuration Task List, page 738
- CMPC+ Router Configuration Task List, page 740
- Correlating the Mainframe and Router Configuration, page 744
- Verifying a CMPC+ Configuration Using TCP/IP, page 746
- Verifying a CMPC+ Configuration Using HSAS, page 754

CMPC+ Configuration Guidelines

To configure the CMPC+ feature, you must configure the host VTAM parameters, the TCP/IP or HSAS stacks on the host, and the CMCC adapter. Consider the following guidelines as you prepare to configure CMPC+ support:

- A CMPC+ link uses two subchannels: one read and one write. Some IBM implementations of MPC+ allow multiple read and multiple write subchannels within a link. CMPC+ does not support multiple read and write subchannels. Only one read subchannel and one write subchannel can be configured for each CMPC+ link. A CMPC+ link is also referred to as a CMPC+ transmission group (TG).
- On the router a CMPC+ transmission group consists of one read subchannel definition, one write subchannel definition, and a transmission group definition, associated by a unique *tg-name*.
- A CMCC adapter can have multiple CMPC+ links (TGs), up to a maximum of 64.
- To configure the TCP/IP or HSAS interface for the CMCC adapter, use the **tg** (CMPC+) command.
- To define the host subchannel (or path) and device, use the **cmnpc** command on the router. One **cmnpc** command defines the read subchannel, and one **cmnpc** command defines the write subchannel. The **cmnpc** command is configured on the CMCC adapter's physical interface (port 0 or 1 on a CIP; port 0 on a CPA).
- The two subchannels in a CMPC+ link do not need to be adjacent devices. Either channel can be the read subchannel or the write subchannel. The two subchannels can be on separate channel process IDs (CHPIDs) in the host.
- The two subchannels must be connected to the same CMCC adapter, however they do not have to be connected to the same physical channel interface on a CIP. On a CIP it is possible to connect a read subchannel to channel interface 0, while the write subchannel is connected to channel interface 1.
- The host IOCP or HCD parameters must coordinate with the **cmnpc** command parameters on the router and the transport resource list major node definition to specify the subchannel path, device, and subchannel address.

- To configure MPC+ on the host, define the Transport Resource List (TRL). If you do not plan to support HPR, then you need to disable support in the TRL major node by configuring HPR=NO.
- CMPC+ can coexist with CLAW, TCP/IP offload, IP host backup, CSNA, CMPC, and TN3270 server features on the router.

CMPC+ Host Configuration Task List

This section contains the following host configuration tasks:

- Configuring the VTAM Transport Resource List Major Node
- Configuring the Stacks

Configuring the VTAM Transport Resource List Major Node

The CMPC+ feature supports standard Transport Resource List (TRL) major node configurations, standard TCP Profiles and OE configuration statements. The host configuration must be coordinated with the CMPC+ configuration for IP connectivity to be successful.

To define the TRL, you must have two valid subchannel addresses configured in the IOCP or HCD on the host that can be used for the read and write subchannels. The read/write subchannels that you configure in the TRL should correlate with the unit addresses configured in the *device* argument of the **cmpc** commands. CMPC+ requires a unique TRLE for each CMPC+ TG.

Figure 284 shows an example of a typical TRL configuration.

Figure 284 Sample Transport Resource List Major Node

```
JECTR LG VBUILD TYPE=TRL
JCTR LG74 TRLE LNCTL=MPC, X
          MAXBFRU=16, X
          REPLYTO=25.5, X
          MPCLEVEL=NOHPDT, X
          READ=(274), X
          WRITE=(275)
```

In this example, device 274 has been configured for read and 275 has been configured for write. Devices 274 and 275 must be available subchannels in the IOCP or HCD definition for the CMCC adapter connection.

You should activate the TRL before activating the corresponding local major node. The following example shows the command to activate a TRL, where the ID parameter specifies the name of the TRL:

```
v net,act,id=jectrlg,update=add
```



Note

The argument “update=add” is preferred and is the default for later versions of VTAM. The argument “update=all” can cause inactive TRLEs to be deleted unexpectedly from ISTTRL. However, “update=all” must be used if you change an active TRL data set and want the changes to become active.

The following commands are useful for displaying the current list of TRLEs:

- **d net,trl**
- **d net,id=isttrl,e**
- **d net,trl,trle=trle_name**

For details on how to configure the TRL major node, see the following IBM documents:

- *VTAM Resource Definition Samples*, SC31-6554
- *VTAM Operation*, SC31-6549
- *VTAM Network Implementation Guide*, SC31-6548

Configuring the Stacks

This section provides samples for the following tasks:

- Configuring the IBM TCP/IP Stack
- Configuring the HSAS Stack

Configuring the IBM TCP/IP Stack

Following is an excerpt of a sample TCP/IP profile. The most important configuration commands are in bold:

```

DEVICE JCTRLG74 MPCPTP
LINK JECIP1 MPCPTP JCTRLG74
;
telnetparms
    TIMEMARK 600
    PORT 23
    DBCSTRANSFORM
endtelnetparms
;
ASSORTEDPARMS NOFWD ENDASSORTEDPARMS
;
PORT
    20 TCP OMVS          NOAUTOLOG ; FTP Server
    21 TCP OMVS          ; FTP Server
    23 TCP INTCLIEN      ; TELNET Server 3.4
    25 TCP SMTP          ; SMTP Server
    53 TCP NAMESRV       ; Domain Name Server
    53 UDP NAMESRV       ; Domain Name Server
    111 TCP OMVS         ; OE Portmap Server
    111 UDP OMVS         ; OE PORTmap Server
    135 UDP NCSLLBD      ; NCS Location Broker
    161 UDP SNMPD        ; SNMP Agent
    162 UDP SNMPQE       ; OE SNMPQE Agent
    515 TCP LPSERVE      ; LPD Server
    520 UDP OROUTED      ; OE RouteD Server
    750 TCP MVSKERB      ; Kerberos
    750 UDP MVSKERB      ; Kerberos
    751 TCP ADM@SRV      ; Kerberos Admin Server
    751 UDP ADM@SRV      ; Kerberos Admin Server
    2049 UDP MVS NFS     ; NFS Server
    3000 TCP CICSTCP     ; CICS Socket
HOME
    172.18.20.51 JECIP1
GATEWAY
    172.18.20.49 = JECIP1 32000 HOST
    DEFAULTNET 172.18.20.49 JECIP1 4468 0

```

```

;
; TRANSLATE
BEGINVTAM
  3278-2-E NSX32702 ; 24 line screen
  3279-2-E NSX32702 ; 24 line screen
  3278-3-E NSX32703 ; 32 line screen - default of NSX32702 is 24 lines
  3279-3-E NSX32703 ; 32 line screen - default of NSX32702 is 24 lines
  3278-4-E NSX32704 ; 48 line screen - default of NSX32702 is 24 lines
  3279-4-E NSX32704 ; 48 line screen - default of NSX32702 is 24 lines
  3278-5-E NSX32705 ; 132 column screen - default of NSX32702 is 80
  3279-5-E NSX32705 ; 132 column screen - default of NSX32702 is 80
DEFAULTLUS
  TCP20000..TCP20999 ; allow 1000 LU-LU SESSIONS on this TCPIP
  ENDEFAULTLUS
ALLOWAPPL * ; Allow access to all applications
USSTCP USSTCPMG JECIP1
ENDVTAM
DATASETPREFIX TCPMSG.TCPIP4
START JCTRLG74

```

For the CMCC adapter, the MTU size on the DEFAULTNET statement must be 4468 or less to ensure that the CMCC adapter does not receive packets larger than the CMCC adapter's MTU.

Configuring the HSAS Stack

Following are the sample OE configuration commands for configuring and activating the HSAS stack:

```

oeifconfig trle host-ip-addr router-ip-addr [mtu size] [netmask netmask]
oeifconfig trle [up|down|detach]
oeroute [flags] [add|delete] [default|dest-ip-addr gateway-ip-addr [metric]]
oenetopts [+a [config-file-name]]

```

For HSAS, the MTU size must be set to 4468.

CMPC+ Router Configuration Task List

This section describes the configuration tasks associated with the CMPC+ feature.

- Assigning an IP Address to the Network Interface
- Configuring the CMPC+ Subchannels
- Configuring the CMPC+ Transmission Groups

Assigning an IP Address to the Network Interface

To assign an IP address to the network interface, use the following command in interface configuration mode:

Command	Purpose
Router(config-if)# ip address <i>ip-address</i> <i>mask</i> secondary	Assigns an IP address to the network interface.

Configuring the CMPC+ Subchannels

Configuring the CMPC+ subchannels establishes the physical path between the CMCC interface and the mainframe channel.

To define a CMPC+ read subchannel and CMPC+ write subchannel, use the following commands beginning in global configuration mode:

Command	Purpose
Step 1 Router(config)# interface <i>channel slot/port</i>	Selects the interface on which to configure CMPC. The <i>port</i> value differs by the type of CMCC adapter: <ul style="list-style-type: none"> • CIP—<i>port</i> value corresponds to the physical interface, which is port 0 or 1. • CPA—<i>port</i> value corresponds to port 0.
Step 2 Router(config-if)# cmpc path device tg-name read	Defines the CMPC+ read subchannel device with the following arguments: <ul style="list-style-type: none"> • <i>path</i>—Four-digit value that represents the channel path for the device. The path value is always 0100 for parallel channels. • <i>device</i>—Unit address for the device on the subchannel. • <i>tg-name</i>—Name of the CMPC+ transmission group, up to 8 characters.
Step 3 Router(config-if)# cmpc path device tg-name write	Defines the CMPC+ write subchannel device with the following arguments: <ul style="list-style-type: none"> • <i>path</i>—Four-digit value that represents the channel path for the device. The path value is always 0100 for parallel channels. • <i>device</i>—Unit address for the device on the subchannel. This unit address must be a different address than the unit address for the CMPC+ read subchannel. • <i>tg-name</i>—Name of the CMPC+ transmission group, up to eight characters.

Use the **no cmpc path device** command to remove the definition of a subchannel.

Mainframe Configuration Tips

- Configuring the subchannel information in the router requires that you correlate the *path* and *device* information from the IOCP or HCD file on the host.
 - The *path* argument is a four-digit hexadecimal value that concatenates the path value (two digits), EMIF partition number (one digit), and control unit logical address (one digit).
 - The *device* argument is a valid number in the UNITADD range of the IOCP CNTLUNIT statement for the CMPC internal LAN adapter.

For detailed information about how to determine the *path* and *device* values for the **cmpc** command, see the “Correlating Channel Configuration Parameters” section in the “Configuring Cisco Mainframe Channel Connection Adapters” chapter in this guide.

- The **cmpc** commands on the router define the subchannel addresses that CMPC+ will use to connect to the host, and correspond to the definitions in the TRL major node on the host. Normally, the last two hexadecimal digits in the READ parameter of the TRL match the value of the *device* argument in the corresponding **cmpc read** command. Similarly, the last two hexadecimal digits in the WRITE parameter of the TRL match the value of the *device* argument in the **cmpc write** command.

Configuring the CMPC+ Transmission Groups

To define a CMPC+ TG by name, use the following command in interface configuration mode on a CIP virtual interface or a CPA physical interface:

	Command	Purpose
Step 1	Router(config)# interface <i>channel slot/port</i>	Selects the interface on which to configure the CMPC+ transmission group. The <i>port</i> value differs by the type of CMCC adapter: <ul style="list-style-type: none"> • CIP—<i>port</i> value corresponds to the virtual interface, which is port 2. • CPA—<i>port</i> value corresponds to port 0.
Step 2	Router(config-if)# tg <i>tg-name</i> [ip hsas-ip] <i>host-ip-addr local-ip-addr broadcast</i>	Defines the type of IP stack and the IP addresses for the CMPC+ connection with the following arguments: <ul style="list-style-type: none"> • <i>tg-name</i>—Name (up to 8 characters) of the transmission group. This name must match the name specified in the cmpc commands. • ip—TCP/IP stack connection for the transmission group. • hsas-ip—HSAS IP stack connection for the transmission group. • <i>host-ip-addr</i>—IP address of the channel-attached host using this transmission group. This address must match the IP address in the HOME statement of the host's TCP/IP profile, or the host address in the <i>source-IP-address</i> argument of the oeifconfig command for HSAS on the host. • <i>local-ip-addr</i>—IP address configured on the virtual interface of the CMCC adapter. This address must match the IP address for the router in the DEFAULTNET statement of the host's TCP/IP profile, or the router address in the <i>destination-IP-address</i> argument of the oeifconfig command for HSAS on the host. • broadcast—Routing updates enabled to the host.

Use the **no tg** command to remove a CMPC+ transmission group from the configuration, which will deactivate the named CMPC+ transmission group. To change any parameter of the **tg** statement, the statement must be removed by using the **no tg** *tg-name* command.

Router Configuration Tip

The *name* that you specify for the transmission group must match the name that you specify in the *tg-name* argument of the **cmpe** commands on the physical interface of the same CMCC adapter.

Mainframe Configuration Tips

- The IP address that you specify for the *host-ip-addr* argument must match one of the following host configuration parameters:
 - For TCP/IP profile configurations, the *host-ip-addr* address must match the IP address specified in the HOME statement at the host.
 - For HSAS stack configurations, the *host-ip-addr* address must match the IP address specified in the *source-IP-address* argument of the **oeifconfig** command at the host.
- The IP address that you specify for the *local-ip-addr* argument must match one of the following host configuration parameters:
 - For TCP/IP profile configurations, the *local-ip-addr* address must match the IP address specified in the DEFAULTNET statement at the host.
 - For HSAS stack configurations, the *local-ip-addr* address must match the IP address specified in the *destination-IP-address* argument of the **oeifconfig** command at the host.

Correlating the Mainframe and Router Configuration

Table 16 shows a summary of the configuration elements on the router and host that must be correlated for proper operation of CMPC+. The column labeled “Configuration Element” identifies the type of entity to be configured. The columns labeled “Router Configuration” and “Mainframe Configuration” identify the related parameters on the router and the mainframe whose values must be compatible or match.

Table 16 Relationship of Configuration Elements for CMPC+

Configuration Element	Router Configuration	Mainframe Configuration
Subchannels	<i>path</i> and <i>device</i> arguments of the cmpc command	RESOURCE PARTITION, CHPID, and CNTLUNIT statements of the IOCP definition defining the following parameters for the CMPC+ channel path: <ul style="list-style-type: none"> • LPAR number (if defined) in the RESOURCE PARTITION and CHPID statements—Specify in the 3rd digit of the <i>path</i> argument in the router cmpc command. • CUADD value (if defined) in the CNTLUNIT statement—Specify in the 4th digit of the <i>path</i> argument in the router cmpc command. • Available device address in the UNITADD parameter of the CNTLUNIT statement—Specify in the <i>device</i> argument of the router cmpc command.
Read/write subchannels	<i>device</i> argument for the cmpr command <i>device</i> argument for the cmcw command	Subchannel for the READ parameter of the TRL major node Subchannel for the WRITE parameter of the TRL major node
Host IP address	<i>host-ip-addr</i> argument for the tg (CMPC+) command	<ul style="list-style-type: none"> • For TCP/IP profile configuration—HOME statement • For HSAS configuration—<i>source-IP-address</i> argument of the oeifconfig command
Router IP address	<i>local-ip-addr</i> argument for the tg (CMPC+) command	<ul style="list-style-type: none"> • For TCP/IP profile configuration—DEFAULTNET statement • For HSAS configuration—<i>destination-IP-address</i> argument of the oeifconfig command

Verifying a CMPC+ Configuration Using TCP/IP

Configuring CMPC+ includes tasks for both the mainframe and the router. This section describes the steps to verify that you have successfully configured CMPC+ on a CIP. It provides procedures to verify connectivity from the router perspective and from the host perspective, and includes troubleshooting tips as a guide when the configuration verification fails.

This section includes the following topics:

- Initial Host and Router Configuration Using the TCP/IP Stack, page 746
- Verifying CMPC+ Channel Connectivity, page 748
- Verifying Communication Between the Host and Router Using TCP/IP, page 751

Initial Host and Router Configuration Using the TCP/IP Stack

When using the TCP/IP stack, consider that you begin verification with the following configurations on the host and router:

- TRL major node (Figure 285)
- Host TCP/IP stack configuration (Figure 286)
- Initial router configuration (Figure 287)



Note

The verification procedures assume that the VTAM major node is defined, but not yet activated.

Figure 285 TRL Major Node Definition

```
JECTRIG VBUILD TYPE=TRL
JCTRIG74 TRLE LNCTL=MPC, X
          MAXBFRU=16, X
          REPLYTO=25.5, X
          MPCLEVEL=NOHPDT, X
          READ=(274), X
          WRITE=(275) X
```

Figure 286 Host TCP/IP Stack Configuration in PROFILE.TCPIP

```

DEVICE JCTRLG74 MPCPTP
LINK JECIP1 MPCPTP JCTRLG74
;
telnetparms
    TIMEMARK 600
    PORT 23
    DBCSTRANSFORM
endtelnetparms
;
ASSORTEDPARMS NOFWD ENDASSORTEDPARMS
;
PORT
    20 TCP OMVS          NOAUTOLOG ; FTP Server
    21 TCP OMVS          ; FTP Server
    23 TCP INTCLIEN      ; TELNET Server 3.4
    25 TCP SMTP          ; SMTP Server
    53 TCP NAMESRV       ; Domain Name Server
    53 UDP NAMESRV       ; Domain Name Server
    111 TCP OMVS         ; OE Portmap Server
    111 UDP OMVS         ; OE PORTmap Server
    135 UDP NCSLLBD      ; NCS Location Broker
    161 UDP SNMPD        ; SNMP Agent
    162 UDP SNMPQE       ; OE SNMPQE Agent
    515 TCP LPSERVE      ; LPD Server
    520 UDP OROUTED      ; OE RouteD Server
    750 TCP MVSKERB      ; Kerberos
    750 UDP MVSKERB      ; Kerberos
    751 TCP ADM@SRV      ; Kerberos Admin Server
    751 UDP ADM@SRV      ; Kerberos Admin Server
    2049 UDP MVSNFS      ; NFS Server
    3000 TCP CICSTCP     ; CICS Socket
HOME
    172.18.20.51 JECIP1
GATEWAY
    172.18.20.49 = JECIP1 32000 HOST
    DEFAULTNET 172.18.20.49 JECIP1 4472 0
;
; TRANSLATE
BEGINVTAM
    3278-2-E NSX32702 ; 24 line screen
    3279-2-E NSX32702 ; 24 line screen
    3278-3-E NSX32703 ; 32 line screen - default of NSX32702 is 24 lines
    3279-3-E NSX32703 ; 32 line screen - default of NSX32702 is 24 lines
    3278-4-E NSX32704 ; 48 line screen - default of NSX32702 is 24 lines
    3279-4-E NSX32704 ; 48 line screen - default of NSX32702 is 24 lines
    3278-5-E NSX32705 ; 132 column screen - default of NSX32702 is 80
    3279-5-E NSX32705 ; 132 column screen - default of NSX32702 is 80
DEFAULTLUS
    TCP20000..TCP20999 ; allow 1000 LU-LU SESSIONS on this TCPIP
    ENDDFAULTLUS
ALLOWAPPL * ; Allow access to all applications
USSTCP USSTCPMG JECIP1
ENDVTAM
DATASETPREFIX TCPMSG.TCPIP4
START JCTRLG74

```

Figure 287 Initial Router Configuration on a CIP

```

interface channel 2/1
  no ip address
  no ip directed-broadcast
  no keepalive
!
interface channel 2/2
  ip address 172.18.20.49 255.255.255.248
  no ip redirects
  no ip directed-broadcast
  no keepalive
  tx-queue-limit 100

```

**Note**

The initial router configuration shows the configuration prior to configuring the CMPC+ feature.

Verifying CMPC+ Channel Connectivity

If you have defined the channel paths for the router at the mainframe host in the IOCP or HCD, you can begin to configure the router for CMPC+ support and verify connectivity at the channel level first. Isolating this level of verification is useful when the VTAM configuration is not completed, but you want to establish that the router can successfully communicate with the host.

Verifying channel connectivity confirms the following aspects of the router configuration:

- Microcode is loaded on the CMCC
- CMCC adapter is functional
- CMCC can communicate with the host over the channel path

This section includes the following tasks:

- Verifying CMPC+ Channel Connectivity From the Router, page 748
- Verifying CMPC+ Channel Connectivity From the Host, page 750
- Troubleshooting Tips for Channel Connectivity, page 750

Verifying CMPC+ Channel Connectivity From the Router

The steps in this section show how to verify the CMPC+ channel configuration beginning with configuring the **cmpc** commands on the router's physical interface. The following assumptions are made for the procedure described in this section:

- The router's virtual interface is already configured with the statements as shown in the initial router configuration for a CIP shown in Figure 287.
- The router has the recommended CMCC hardware and microcode versions to support the CMPC feature. You can use the **show version**, **show controllers cbus**, and **show controllers channel** commands to verify the Cisco IOS software and CMCC microcode versions.

**Note**

Before you begin on the router, run the **debug channel events** command so that you can verify the messages on the router console.

To verify CMPC+ channel connectivity, perform the following steps:

- Step 1** From the router, configure the **cmpc** commands on the physical interface according to your site's requirements as shown in the following example:

```
interface channel 2/1
cmpc C190 74 MVSG-TCP READ
cmpc C190 75 MVSG-TCP WRITE
```

Confirm that you receive messages stating "Device Initialized," similar to the following displays:

```
PA1 MPC C190-74 Device initialized
PA1 MPC C190-75 Device initialized
```

- Step 2** Configure the CMPC+ transmission group according to your site's requirements as shown in the following example:

```
interface channel 2/2
tg MVSG-TCP ip 172.18.20.51 172.18.20.49
```

Confirm that you receive a message stating that the CMPC+ transmission group is "Initialized," similar to the following display:

```
CMPC-TG MVSG-TCP initialized
```

- Step 3** To verify that the channel is up and the line protocol is up, go to EXEC command mode and run the **show interfaces channel** command as shown in the following example:

```
show interfaces channel 2/1
```

- Step 4** To verify that the physical channel is up, run the **show extended channel statistics** command as shown in the following example:

```
show extended channel 2/1 statistics
```

Verify that the path field in the output for the CMPC+ devices shows "ESTABLISHED," which means that the physical channel is up.

- Step 5** If your **show** command output matches the values described in Step 3 and Step 4, then the channel connection between the mainframe and the router is established. If you cannot confirm the values, see the "Troubleshooting Tips for Channel Connectivity" section on page 750.

Verifying CMPC+ Channel Connectivity From the Host

After CMPC+ has been configured on the router, you can also verify channel connectivity from the host by performing the following steps:

- Step 1** From the host, verify that the devices are online using the following sample command to display the device 274 for a range of two (or 274-275):

```
d u, , 274, 2
```

- Step 2** If the devices are offline, then vary the devices online according to your site's configuration as shown in the following sample commands:

```
v 274,online
v 275,online
```



Note The CHPID for the device should already be active on the host.

- Step 3** If the devices come online, then the channel connection between the mainframe and the router is established. If the device does not come online, or you receive the message “No paths physically available,” see the “Troubleshooting Tips for Channel Connectivity” section on page 750.

Troubleshooting Tips for Channel Connectivity

There are several indicators on the router and the mainframe that indicate that the channel connection is not available.

- From the router, you might see the following things:
 - The output from the **show interfaces channel** command shows that the channel or line protocol is down.
 - The output from the **show interface channel statistics** command shows that the path is not established (the physical channel is not up).
- From the host, you might see the following things:
 - The device is not online.
 - When you vary the device online, you receive the message “No paths physically available.”

Recommended Actions

If you determine that the channel connection is not available, review the following tasks to be sure that you have performed them correctly:

- Be sure that you enabled the CMPC+ router configuration using the **no shut** command to restart the interface. If you configured both the physical and virtual interface on a CIP, be sure to run the **no shut** command on both interfaces.
- Be sure that the CMPC+ devices (and paths) are online at the host.
- Verify that the *path* and *device* arguments that you specified in your **cmpe** configuration command correlate properly to the host IOCP or HCD configuration.

If none of these recommended actions allow you to establish the channel connection, check your CMCC LED indicators and the physical channel connection.

Verifying Communication Between the Host and Router Using TCP/IP

After the VTAM TRLE major node definition is installed, the TCP/IP stack is configured, and the router is configured, you can verify communication between the host and router.

This section includes the following verification procedures:

- Verifying Communication From the Host Using TCP/IP, page 751
- Verifying Communication From the Router Using TCP/IP, page 752
- Troubleshooting Tips from the Host Using TCP/IP, page 753
- Troubleshooting Tips from the Router Using TCP/IP, page 753

Verifying Communication From the Host Using TCP/IP

This procedure describes how to verify from the host that the VTAM TRLE major node definition is configured and activated.

To verify communication with VTAM using CMPC+, perform the following steps:

Step 1 Activate the TRLE using the following sample command:

```
v net,act,id=JCTRLG74,update=add
```

Verify that you receive the following console messages:

```
IST097I VARY ACCEPTED
IST093I ISTRL ACTIVE
```

Step 2 Display the TRLE status using the following command:

```
d net,trl
```

Verify that the TRLE is present but not active, as shown in the following console message:

```
IST1314I TRLE=JCTRLG74 STATUS=NEVAC CONTROL=MPC
```

Step 3 Start the TCP/IP task using the following sample command:

```
s TCPMVSG4
```

Verify that the TCP/IP task starts, the TRLE device and HSAS stack initializes and the interfaces are active as shown in the following console messages:

```
$HASP100 TCPMVSG4 ON STCINRDR
IEF695I START TCPMVSG4 WITH JOBNAME TCPMVSG4 IS ASSIGNED TO USER
OMVSKERN, GROUP OMVSGRP
$HASP373 TCPMVSG4 STARTED
IEF403I TCPMVSG4 - STARTED - TIME=11.33.21
IEE252I MEMBER CTIEZB00 FOUND IN SYS1.OS390R7.PARMLIB
EPW0250I EPWPITSK: FFST INITIALIZATION FOR TCP COMPLETE
EZZ0300I OPENED PROFILE FILE DD:PROFILE
EZZ0309I PROFILE PROCESSING BEGINNING FOR DD:PROFILE
EZZ0316I PROFILE PROCESSING COMPLETE FOR FILE DD:PROFILE
EZZ0334I IP FORWARDING IS DISABLED
EZZ0335I ICMP WILL NOT IGNORE REDIRECTS
EZZ0337I CLAWUSEDoublENOP IS CLEARED
IEF196I IEF237I 0275 ALLOCATED TO TP0275
EZZ0345I STOPONCLAWERROR IS DISABLED
EZZ4202I OPENEDITION-TCP/IP CONNECTION ESTABLISHED FOR TCPMVSG4
BPXF206I ROUTING INFORMATION FOR TRANSPORT DRIVER TCPMVSG4 HAS BEEN
```

```
INITIALIZED OR UPDATED.
IEF196I IEF237I 0274 ALLOCATED TO TP0274
EZZ4313I INITIALIZATION COMPLETE FOR DEVICE JCTRLG74
EZZ4324I CONNECTION TO 172.18.20.49 ACTIVE FOR DEVICE JCTRLG74
EZB6473I TCP/IP STACK FUNCTIONS INITIALIZATION COMPLETE.
EZAIN11I ALL TCPIP INTERFACES FOR PROC TCPMVSG4 ARE ACTIVE.
```

Verifying Communication From the Router Using TCP/IP

This procedure describes how to verify communication with the VTAM TRL major node and the TCP/IP stack from the router.

To verify communication with VTAM from the router, perform the following steps:

- Step 1** Run the **show extended channel statistics** command as shown in the following example:

```
show extended channel 2/1 statistics
```

Verify that the following is displayed in these fields of the output for the CMPC+ devices:

- Path—The CMPC+ path is “ESTABLISHED,” which means that the physical channel is up.
- Con—The connection value is “Y,” which means that the subchannel is up and the CMPC+ connection is established between the router and the mainframe.

- Step 2** To verify that the CMPC+ subchannels are active, run the **show extended channel cmpc** command as shown in the following example:

```
show extended channel 2/0 cmpc
```

- Step 3** To verify the operational status and configuration of the CMPC+ transmission groups, run the **show extended channel tg** command as shown in the following example:

```
show extended channel 2/2 tg detailed MVSG-TCP
```

- Step 4** When the TCP/IP task has been started at the host, verify that you receive a message stating that the connection is activated as shown in the following example:

```
MVSG-TCP: Tcp/Ip Connection Activated
```

- Step 5** To confirm that you can establish a connection to the host, run the following **ping** command at the router console and specify the IP address that is configured in the HOME statement of the TCP/IP profile (Figure 286):

```
router# ping 172.18.20.51
```

Verify that you receive a successful response to the **ping** command as shown in the following example:

```
Sending 5, 100-byte ICMP Echos to 172.18.20.51, timeout is 2 seconds:
!!!!
Success rate is 100 percent (5/5), round-trip min/avg/max = 12/12/12 ms
```

For information about other commands that are useful when diagnosing or monitoring your CMPC+ connection, see the “Monitoring and Maintaining CMPC+” section on page 760.

Troubleshooting Tips from the Host Using TCP/IP

This section describes recommended actions for the following problems that might occur during verification of communication between the host and router.

From the host, you receive the following messages when you start the TCP/IP task:

```
$HASP100 TCPMVSG4 ON STCINRDR
IEF695I START TCPMVSG4 WITH JOBNAME TCPMVSG4 IS ASSIGNED TO USER
OMVSKERN, GROUP OMVSGRP
$HASP373 TCPMVSG4 STARTED
IEF403I TCPMVSG4 - STARTED - TIME=11.40.57
IEE252I MEMBER CTIEZB00 FOUND IN SYS1.OS390R7.PARMLIB
EPW0250I EPWPITSK: FFST INITIALIZATION FOR TCP COMPLETE
EZZ0300I OPENED PROFILE FILE DD:PROFILE
EZZ0309I PROFILE PROCESSING BEGINNING FOR DD:PROFILE
EZZ0316I PROFILE PROCESSING COMPLETE FOR FILE DD:PROFILE
EZZ0334I IP FORWARDING IS DISABLED
EZZ0335I ICMP WILL NOT IGNORE REDIRECTS
EZZ4308I ERROR: CODE=80103016 DURING ACTIVATION OF DEVICE JCTRLG74.
DIAGNOSTIC CODE: 02
EZZ0337I CLAWUSEDDOUBLENOP IS CLEARED
EZZ0345I STOPONCLAWERROR IS DISABLED
EZZ4202I OPENEDITION-TCP/IP CONNECTION ESTABLISHED FOR TCPMVSG4
BPXF206I ROUTING INFORMATION FOR TRANSPORT DRIVER TCPMVSG4 HAS BEEN
INITIALIZED OR UPDATED.
EZZB6473I TCP/IP STACK FUNCTIONS INITIALIZATION COMPLETE.
EZZAIN11I ALL TCPIP INTERFACES FOR PROC TCPMVSG4 ARE ACTIVE.
EZZ0400I TELNET/VTAM (SECOND PASS) BEGINNING FOR FILE: DD:PROFILE
EZZ6025I TELNET SEARCH OF USSTCPMG FAILED, RC = 00000004 RSN = 00000004
EZZ6003I TELNET LISTENING ON PORT 23
EZZ0403I TELNET/VTAM (SECOND PASS) COMPLETE FOR FILE: DD:PROFILE
EZZ6027I TELNET TRANSFORM INITIALIZATION FAILED, RC: FFFF
EZZ6028I TELNET TRANSFORM HAS ENDED
```

Recommended Action

Verify that the TRL major node is active at the host.

Troubleshooting Tips from the Router Using TCP/IP

This section describes recommended actions for the following problems that might occur during verification of communication between the host and router.

- From the router, the **ping** command to the host fails as shown in the following example:

```
Sending 5, 100-byte ICMP Echos to 172.18.20.51, timeout is 2 seconds:
.....
Success rate is 0 percent (0/5)
```

Recommended Actions

- Verify that the TRL major node is active at the host.
- Verify that the IP address for the router in the TCP/IP profile matches the local IP address that you specified in the router's **tg** configuration command.
- From the router, you receive the following messages when the TCP/IP task is started at the host:

```
%CIP2-6-MSG: slot2 %MPC-6-CMPCP_CV_LOG: MVSG-TCP: Event/State
PRE_VcActInd/PRS_Reset
%CIP2-3-MSG: slot2 %MPC-3-CMPCP_CV_ERR2: Possible Config error:
Rcvd Host Local IP: 172.18.20.51, Expected: 172.18.20.52
```



Note Ignore any other error messages that might follow these errors on the router console until you follow the recommended action to resolve the problem.

Recommended Action

- Verify that the IP address for the host in the TCP/IP profile matches the remote IP address that you specified in the router's **tg** configuration command.
- From the router, you receive the following messages when the TCP/IP task is started at the host:

```
%CIP2-6-MSG: slot2 %MPC-6-CMPCP_CV_LOG: MVSG-TCP: Event/State
PRE_VcActInd/PRS_Reset
%CIP2-3-MSG: slot2 %MPC-3-CMPCP_CV_ERR2: Possible Config error:
Rcvd protocol: TCP/IP, Expected: HSAS/IP
```



Note Ignore any other error messages that might follow these errors on the router console until you follow the recommended action to resolve the problem.

Recommended Action

- Verify that the router's **tg** configuration command specifies the **ip** protocol keyword and not **hsas-ip**.

Verifying a CMPC+ Configuration Using HSAS

Configuring CMPC+ includes tasks for both the mainframe and the router. This section describes the steps to verify that you have successfully configured CMPC+ on a CIP. It provides procedures to verify connectivity from the router perspective and from the host perspective, and includes troubleshooting tips as a guide when the configuration verification fails.

This section includes the following topics:

- Initial Host and Router Configuration Using the HSAS Stack, page 754
- Verifying CMPC+ Channel Connectivity, page 755
- Verifying Communication Between the Host and Router Using HSAS, page 757

Initial Host and Router Configuration Using the HSAS Stack

When using the HSAS stack, consider that you begin verification with the following configurations on the host and router:

- TRL major node (Figure 288)
- Initial router configuration (Figure 289)



Note The verification procedures assume that the VTAM major node is defined, but not yet activated.

Figure 288 TRL Major Node Definition

```

HSASTRLG VBUILD TYPE=TRL
HSASTR72 TRLE LNCTL=MPC,MAXBFRU=16,          X
          READ=(272),                          X
          WRITE=(273)

```

Figure 289 Initial Router Configuration on a CIP

```

interface Channel2/1
  no ip address
  no ip directed-broadcast
  no keepalive
!
interface Channel2/2
  ip address 172.18.20.49 255.255.255.248
  no ip redirects
  no ip directed-broadcast
  no keepalive
  tx-queue-limit 100

```

**Note**

The initial router configuration shows the configuration prior to configuring the CMPC+ feature.

Verifying CMPC+ Channel Connectivity

If you have defined the channel paths for the router at the mainframe host in the IOCP or HCD, you can begin to configure the router for CMPC+ support and verify connectivity at the channel level first. Isolating this level of verification is useful when the VTAM configuration is not completed, but you want to establish that the router can successfully communicate with the host.

Verifying channel connectivity confirms the following aspects of the router configuration:

- Microcode is loaded on the CMCC
- CMCC adapter is functional
- CMCC can communicate with the host over the channel path

Verifying CMPC+ Channel Connectivity From the Router

The steps in this section show how to verify the CMPC+ channel configuration beginning with running the **cmpc** command on the router's physical interface. The following assumptions are made for the procedure described in this section:

- The router's virtual interface is already configured with the statements as shown in the initial router configuration for a CIP shown in Figure 289.
- The router has the recommended CMCC hardware and microcode versions to support the CMPC feature. You can use the **show version**, **show controllers cbus**, and **show controllers channel** commands to verify the Cisco IOS software and CMCC microcode versions.

**Note**

Before you begin on the router, run the **debug channel events** command so that you can verify the messages on the router console.

To verify CMPC+ channel connectivity, perform the following steps:

- Step 1** From the router, configure the **cmpc** commands on the physical interface according to your site's requirements as shown in the following example:

```
interface channel 2/1
cmpc C190 72 MVSG-HSA READ
cmpc C190 73 MVSG-HSA WRITE
```

Confirm that you receive messages stating "Device Initialized," similar to the following displays:

```
PA1 MPC C190-72 Device initialized
PA1 MPC C190-73 Device initialized
```

- Step 2** Configure the CMPC+ transmission group according to your site's requirements as shown in the following example:

```
interface channel 2/2
tg MVSG-HSA ip 172.18.20.50 172.18.20.49
```

Confirm that you receive a message stating that the CMPC+ transmission group is "Initialized," similar to the following display:

```
CMPC-TG MVSG-HSA initialized
```

- Step 3** To verify that the channel is up and the line protocol is up, go to EXEC command mode and run the **show interfaces channel** command as shown in the following example:

```
show interfaces channel 2/1
```

- Step 4** To verify that the physical channel is up, run the **show extended channel statistics** command as shown in the following example:

```
show extended channel 2/1 statistics
```

Verify that the path field in the output for the CMPC+ devices shows "ESTABLISHED," which means that the physical channel is up.

- Step 5** If your **show** command output matches the values described in Step 3 and Step 4, then the channel connection between the mainframe and the router is established. If you cannot confirm the values, see the "Troubleshooting Tips for Channel Connectivity" section on page 757.

Verifying CMPC+ Channel Connectivity From the Host

After CMPC+ has been configured on the router, you can also verify channel connectivity from the host by performing the following steps:

- Step 1** From the host, verify that the devices are online using the following sample command to display the device 272 for a range of two (or 272-273):

```
d u , , 272 , 2
```

- Step 2** If the devices are offline, then vary the devices online according to your site's configuration as shown in the following sample commands:

```
v 272,online
v 273,online
```



Note The CHPID for the device should already be active on the host.

- Step 3** If the devices come online, then the channel connection between the mainframe and the router is established. If the device does not come online, or you receive the message “No paths physically available,” see the “Troubleshooting Tips for Channel Connectivity” section on page 757.

Troubleshooting Tips for Channel Connectivity

There are several indicators on the router and the mainframe that indicate that the channel connection is not available.

- From the router, you might see the following things:
 - The output from the **show interfaces channel** command shows that the channel or line protocol is down.
 - The output from the **show interface channel statistics** command shows that the path is not established (the physical channel is not up).
- From the host, you might see the following things:
 - The device is not online.
 - When you vary the device online, you receive the message “No paths physically available.”

Recommended Actions

If you determine that the channel connection is not available, review the following tasks to be sure that you have performed them correctly:

- Be sure that you enabled the CMPC+ router configuration using the **no shut** command to restart the interface. If you configured both the physical and virtual interface on a CIP, be sure to run the **no shut** command on both interfaces.
- Be sure that the CMPC+ devices (and paths) are online at the host.
- Verify that the *path* and *device* arguments that you specified in your **cmpe** configuration command correlate properly to the host IOCP or HCD configuration.

If none of these recommended actions allow you to establish the channel connection, check your CMCC LED indicators and the physical channel connection.

Verifying Communication Between the Host and Router Using HSAS

After the VTAM TRL major node definition is installed and the router is configured, you can configure the HSAS stack on the host and verify communication between the host and router.

This section includes the following verification procedures:

- Verifying Communication From the Host Using HSAS, page 758
- Verifying Communication From the Router Using HSAS, page 758
- Troubleshooting Tips From the Router Using HSAS, page 759

Verifying Communication From the Host Using HSAS

This procedure describes how to verify from the host that the VTAM TRLE major node definition is configured and activated.

To verify communication with VTAM using CMPC+, perform the following steps:

Step 1 Activate the TRLE using the following sample command:

```
v net,act,id=HSASTR72,update=add
```

Verify that you receive the following console messages:

```
IST097I VARY ACCEPTED
IST093I ISTTRL ACTIVE
```

Step 2 Display the TRLE status using the following command:

```
d net,trl
```

Verify that the TRLE is present but not active, as shown in the following console message:

```
IST1314I TRLE=HSASTR72 STATUS=NEVAC CONTROL=MPC
```

Step 3 From the TSO/ISPF menu at the host, enter Open Edition by typing L8.4.

Step 4 To configure the HSAS stack on the host, type the **oeifconfig** command as shown in the following example:

```
oeifconfig hsastr72 172.18.20.50 172.18.20.49 mtu 4468
```

Step 5 Display the HSAS configuration using the following command:

```
oenetstat -r
```

Verify that you receive a display similar to the following messages:

Destination	Gateway	Flags	Refs	Use	Unreach	Interface
172.18.20.49	172.18.20.49	UH	0	0	0	HSASTR72
172.18.20.50	*	UHL	0	0	0	HSASTR72
127.0.0.0	*	UL	0	0	0	LOO

Verifying Communication From the Router Using HSAS

This procedure describes how to verify communication with the VTAM TRLE major node and the HSAS stack from the router.

To verify communication with VTAM from the router, perform the following steps:

Step 1 Run the **show extended channel statistics** command as shown in the following example:

```
show extended channel 2/1 statistics
```

Verify that the following is displayed in these fields of the output for the CMPC+ devices:

- Path—The CMPC+ path is “ESTABLISHED,” which means that the physical channel is up.
- Con—The connection value is “Y,” which means that the subchannel is up and the CMPC+ connection is established between the router and the mainframe.

- Step 2** To verify that the CMPC+ subchannels are active, run the **show extended channel cmpc** command as shown in the following example:

```
show extended channel 2/0 cmpc
```

- Step 3** To verify the operational status and configuration of the CMPC+ transmission groups, run the **show extended channel tg** command as shown in the following example:

```
show extended channel 2/2 tg detailed MVSG-HSA
```

- Step 4** When the HSAS task is configured at the host, verify that you receive a message stating that the connection is activated as shown in the following example:

```
MVSG-HSA: Hsas/Ip Connection Activated
```

- Step 5** To confirm that you can establish a connection to the host, run the following **ping** command at the router console and specify the IP address that is configured in the **oeifconfig** command at the host:

```
router# ping 172.18.20.50
```

Verify that you receive a successful response to the **ping** command as shown in the following example:

```
Sending 5, 100-byte ICMP Echos to 172.18.20.50, timeout is 2 seconds:
!!!!
Success rate is 100 percent (5/5), round-trip min/avg/max = 12/12/16 ms
```

For information about other commands that are useful when diagnosing or monitoring your CMPC+ connection, see the “Monitoring and Maintaining CMPC+” section on page 760.

Troubleshooting Tips From the Router Using HSAS

This section describes recommended actions for the following problems that might occur during verification of communication between the host and router.

- From the router, the “Hsas/Ip Connection Activated” message does not appear and the **ping** command times out:

Recommended Action

- Verify that the IP address for the host in the **oeifconfig** command at the host matches the remote IP address that you specified in the router’s **tg** configuration command.
- Verify that the TRL activated successfully at the host.
- From the router, you receive the following messages when the **oeifconfig** command is run at the host:

```
%CIP2-6-MSG: slot2 %MPC-6-CMPCP_CV_LOG: MVSG-HSA: Event/State
PRE_VcActInd/PRS_Reset
%CIP2-3-MSG: slot2 %MPC-3-CMPCP_CV_ERR2: Possible Config error:
Rcvd Local Addr: 172.18.20.49, Expected: 172.18.20.51
```



Note Ignore any other error messages that might follow these errors on the router console until you follow the recommended action to resolve the problem.

Recommended Action

Verify that the IP address for the router in the **oeifconfig** command matches the local IP address that you specified in the router’s **tg** configuration command.

- From the router, you receive the following messages when the **oeifconfig** command is run at the host:

```
%CIP2-6-MSG: slot2 %MPC-6-CMPCP_CV_LOG: MVSG-HSA: Event/State
PRE_VcActInd/PRS_Reset
%CIP2-3-MSG: slot2 %MPC-3-CMPCP_CV_ERR2: Possible Config error:
Rcvd protocol: HSAS/IP, Expected: TCP/IP
```



Note Ignore any other error messages that might follow these errors on the router console until you follow the recommended action to resolve the problem.

Recommended Action

Verify that the router's **tg** configuration command specifies the **hsas-ip** protocol keyword and not **ip**.

Monitoring and Maintaining CMPC+

The following topics in this section provide information about the different commands that you can use to monitor and maintain the CMCC interfaces that are configured for CMPC+:

- Monitoring Interface Status
- Clearing Counters for CMPC+

Monitoring Interface Status

To monitor CMCC adapter interface status, you can display information about the interface, including the version of the software and the hardware, the controller status, and statistics about the interfaces. In addition, you can display information about feature-related statistics on the CMCC adapter. This section lists some additional commands that are useful when monitoring CMCC adapter interfaces that are configured for CMPC+.

For a complete list of the **show** commands that are related to monitoring CMCC adapter interfaces, see the “Configuring Cisco Mainframe Channel Connection Adapters” chapter in this guide. To display the full list of **show** commands, enter **show ?** at the EXEC prompt.

To display information related to CMPC+ configurations, use the following commands in EXEC mode:

Command	Purpose
Router# show extended channel slot/port cmgr [<i>tg-name</i>]	Displays information about the MPC+ TG connection manager.
Router# show extended channel slot/port cmpc [<i>path</i> [<i>device</i>]]	Displays information about each CMPC+ (and CMPC) subchannel configured on the specified CMCC adapter interface.
Router# show extended channel slot/port tg [<i>oper</i> <i>stats</i>] [<i>detailed</i>] [<i>tg-name</i>]	Displays configuration, operational, and statistics information for CMPC+ (and CMPC) transmission groups configured on a specified CMCC adapter internal LAN interface.

Clearing Counters for CMPC+

You can reset the statistics counters that are displayed in the output of the **show extended channel** commands. You can reset the counters associated with an interface or a particular feature on the interface. If you are monitoring a particular threshold or statistic for a CMPC+ transmission group and need to reset a related counter, you can clear all those counters related to the transmission group.

For information about clearing other counters on the CMCC adapter interface, see the “Configuring Cisco Mainframe Channel Connection Adapters” chapter in this guide.

To clear the transmission group counters associated with CMPC+ on the CMCC adapters, use the following command in privileged EXEC mode:

Command	Purpose
Router# clear extended counters channel slot/port tg	<p>Clears counters for statistics associated with transmission groups in the CMPC+ (and CMPC) features on the specified <i>slot/port</i>. The port value differs by the type of CMCC adapter:</p> <ul style="list-style-type: none"> • CIP—<i>port</i> value corresponds to the virtual interface, which is port 2. • CPA—<i>port</i> value corresponds to the physical interface, which is port 0.



Note

This command will not clear counters retrieved using Simple Network Management Protocol (SNMP), but only those seen with the EXEC **show extended channel tg** command.

Configuration Examples

Following are the CMPC+ configuration examples shown in this section:

- CMPC+ with TCP/IP Stack Example, page 762
- CMPC+ with HSAS Stack Example, page 763
- CMPC+ with TCP/IP and HSAS Stacks Example, page 765
- CMPC+ TG Using Two Interfaces Example, page 767

CMPC+ with TCP/IP Stack Example

Figure 290 illustrates TCP/IP link for CMPC+ between a Host and a Cisco router with a CMCC adapter. The configurations for this example follow.

Figure 290 CMPC+ IP with TCP/IP

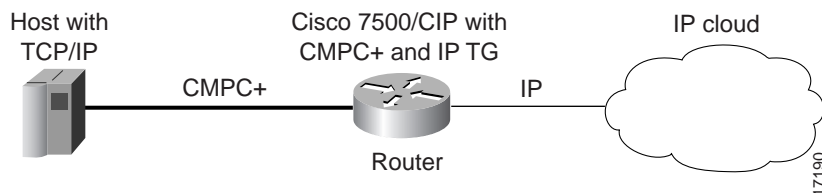

Router

The following configuration is for the CIP in the Cisco 7500 router:

```

hostname ipclust1
!
microcode CIP flash slot0:cip27-4
microcode reload
!
interface Channel0/1
no ip address
no keepalive
cmpc 0170 00 TG00 READ
cmpc 0170 01 TG00 WRITE
!
interface Channel0/2
ip address 80.12.165.1 255.255.255.0
no ip redirects
no ip directed-broadcast
ip route-cache same-interface
no ip mroute-cache
load-interval 30
no keepalive

tg TG00 ip 80.12.165.2 80.12.165.1

```

In this configuration, the CMPC+ configuration is for the TCP/IP stack on the host. The host IP address of 80.12.165.2 in the TG statement corresponds to the IP address for the TCP/IP stack in the TCP/IP profile on the host. The IP address for the CIP is 80.12.165.1.

TCP/IP Profile

The following sample shows the TCP/IP Profile on the Host:

```

ARPAGE 5
telnetparms timemark 600 port 23 dbcstransform endtelnetparms
ASSORTEDPARMS NOFWD ENDASSORTEDPARMS
;
DEVICE mpc4b00 MPCPTP
LINK MPCPLNK2 MPCPTP mpc4b00
;
AUTOLOG
OEF TPE3
ENDAUTOLOG
INCLUDE TODD.MPCP.TCPIP.PROFILES (PORTS)
HOME

```

```

      80.12.165.2   MPCPLNK2
GATEWAY
; NETWORK      FIRST      DRIVER      PACKET      SUBNet mask      subnet value
;              HOP              SIZE
      80.12.165.1   =      mpcplnk2      4468      host
DEFAULTNET 80.12.165.1 mpcplnk2 4468      0
BEGINVTAM
      ; Define logon mode tables to be the defaults shipped with the latest
      ; level of VTAM
      3278-3-E NSX32703 ; 32 line screen - default of NSX32702 is 24 line screen
      3279-3-E NSX32703 ; 32 line screen - default of NSX32702 is 24 line screen
      3278-4-E NSX32704 ; 48 line screen - default of NSX32702 is 24 line screen
      3279-4-E NSX32704 ; 48 line screen - default of NSX32702 is 24 line screen
      3278-5-E NSX32705 ; 132 column screen - default of NSX32702 is 80 columns
      3279-5-E NSX32705 ; 132 column screen - default of NSX32702 is 80 columns
      ; Define the LUs to be used for general users
DEFAULTAPPL ECHOMVSE
; DEFAULTAPPL ECHOMVSE 10.10.1.188
; DEFAULTAPPL NETTMVSE
DEFAULTTLUS
      TCPE0000..TCPE9999
ENDEFAULTLUS
ALLOWAPPL * ; Allow all applications that have not been previously
              ; specified to be accessed
ENDVTAM
DATASETPREFIX TODD.MPCP
start mpc4b00

```

In this TCP/IP profile, the DEVICE specifies the VTAM TRLE mpc4b00 and LINK specifies the link name (MPCPLNK2) associated with the IP address (80.12.165.2) for that link. The host IP address 80.12.165.2 that is specified for the TG in the router configuration must be identical to the IP address specified for the TG in the router configuration.

TRL Major Node

The following sample shows the TRL major node example:

```

TRL4B00 VBUILD TYPE=TRL
MPC4B00 TRLE LNCTL=MPC,MAXBFRU=16,                                X
              READ=(4B00) ,                                       X
              WRITE=(4B01)

```

In this TRL major node example, the parameter *MPC4B00* must be identical to the LINK parameter in the TCP/IP profile.

CMPC+ with HSAS Stack Example

Figure 291 illustrates HSAS for CMPC+ between a host and a Cisco router with a CMCC adapter. The configurations for this example follow.

Figure 291 CMPC+ IP with HSAS

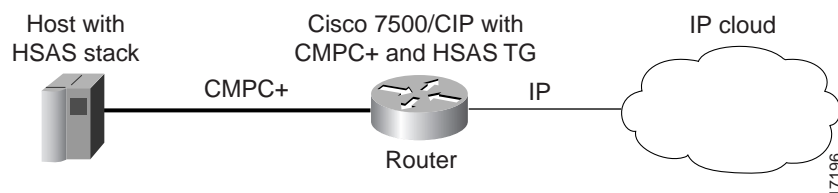

Router

The following sample shows the configuration for the CIP in the Cisco 7500 router:

```
hostname ipclust1
!
microcode CIP flash slot0:cip27-4
microcode reload
!
interface Channel0/1
no ip address
no keepalive
cmpc 0170 02 TG00 READ
cmpc 0170 03 TG00 WRITE
!
interface Channel0/2
ip address 80.12.165.1 255.255.255.0
no ip redirects
no ip directed-broadcast
ip route-cache same-interface
no ip mroute-cache
load-interval 30
no keepalive
tg TG00 hsas-ip 80.12.165.2 80.12.165.1
```

In this configuration, the CMPC + configuration is for the HSAS stack on the host. The IP address of 80.12.165.2 on the CIP corresponds to the HSAS IP address for the HSAS stack on the host.

Stack Definition in the OE Parmlib Member for HSAS

The following example shows the HSAS communications stack defined through the BPXPRMxy member in SYS1.PARMLIB. The most important configuration statement is shown in bold.

```
SYS1.PARMLIB (BPXPRMxy)
.
.
.
FILESYSTYPE      ENTRYPOINT (BPXTCINT)  TYPE (CINET)
NETWORK DOMAINNAME (AF_INET) DOMAINNUMBER (2) MAXSOCKETS (11000)
                  TYPE (CINET) INADDRANYPORT (5000) INADDRANYCOUNT (4000)
SUBFILESYSTYPE NAME (TCPMVSE1) ENTRYPOINT (EZBPFINI) TYPE (CINET)
                  DEFAULT
SUBFILESYSTYPE NAME (TCPMVSE2) ENTRYPOINT (EZBPFINI) TYPE (CINET)
SUBFILESYSTYPE NAME (TCPMVSE3) ENTRYPOINT (EZBPFINI) TYPE (CINET)
SUBFILESYSTYPE NAME (TCPMVSE4) ENTRYPOINT (EZBPFINI) TYPE (CINET)
SUBFILESYSTYPE NAME (TCPMVSE5) ENTRYPOINT (EZBPFINI) TYPE (CINET)
SUBFILESYSTYPE NAME (TCPMVSE6) ENTRYPOINT (EZBPFINI) TYPE (CINET)
SUBFILESYSTYPE NAME (TCPMVSE7) ENTRYPOINT (EZBPFINI) TYPE (CINET)
SUBFILESYSTYPE NAME (TCPMVSE8) ENTRYPOINT (EZBPFINI) TYPE (CINET)
SUBFILESYSTYPE NAME (OESTACK) ENTRYPOINT (BPXUIINT) TYPE (CINET)
```

The OpenEdition Common INET physical file system must be defined to include the HSAS communications stack (OESTACK). Whereas other IP communications stacks require a separate address space, the HSAS communications stack resides within the OpenEdition kernel.

The SUBFILESYSTYPE NAME(OESTACK) statement defines the HSAS stack. This statement must be coded exactly as shown in the example and only one such statement must be coded.

HSAS Configuration

The following sample is the HSAS configuration on the MVS host:

```
oeifconfig mpc4b02 80.80.165.2 80.12.165.1 mtu 4468
oeroute add default 80.12.165.1
```

TRL Major Node

The following sample is the TRL major node configuration:

```

TRL4B02 VBUILD TYPE=TRL
MPC4B02 TRLE LNCTL=MPC,MAXBFRU=16, X
          READ= (4B02) , X
          WRITE= (4B03)

```

In this TRL major node configuration, the parameter *MPC4B02* must be identical to the *trle* parameter in the *oeifconfig* configuration.

CMPC+ with TCP/IP and HSAS Stacks Example

Figure 292 illustrates CMPC+ used between a Cisco router with a CMCC adapter and a host with both TCP/IP and HSAS stacks.

Figure 292 CMPC+ with TCP/IP and HSAS Stacks

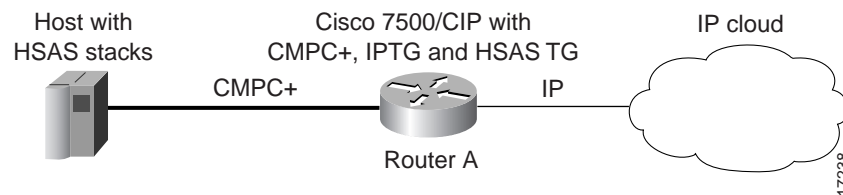

Router

The following is the CMPC+ configuration for TCP/IP and HSAS in the CPA:

```

hostname ipclust2
!
enable secret 5 $1$2Py5$GmguUvRGwLdOj2UCi6cv71
enable password lab
!
microcode ecpa slot0:xcpa216-0.plus110698
microcode reload
ip subnet-zero
ip host bizarre 171.69.160.37
ip domain-name cisco.com
ip name-server 171.69.161.21
!
interface Channel5/0
 ip address 80.80.2.1 255.255.255.0
 no ip directed-broadcast
 ip route-cache same-interface
 no ip mroute-cache
 load-interval 30
 no keepalive
 cmpc 0180 00 TG00 READ
 cmpc 0180 01 TG00 WRITE
 cmpc 0180 02 TG02 READ
 cmpc 0180 03 TG02 WRITE
 tg TG00 ip 80.80.2.2 80.80.2.1
 tg TG02 hsas-ip 80.80.2.3 80.80.2.1

```

In this configuration, the *cmcp* configuration is for the TCP/IP and HSAS stacks on the host. The IP address of 80.80.2.2 corresponds to the IP address for the TCP/IP stack in the TCP/IP profile on the host. The IP address of 80.80.2.3 corresponds to the IP address in the HSAS stack on the host.

TRL Major Node for TCP/IP Stack

The following sample shows the TRL major node configuration for the TCP/IP stack:

```
TRL4900 VBUILD TYPE=TRL
MPC4900 TRLE LNCTL=MPC,MAXBFRU=6,REPLYTO=3,
          READ=(4900),WRITE=(4901)                                x
```

In this TRL major node example, the parameter *MPC4900* must be identical to the TRLE parameter in the LINK statement in the TCP/IP profile.

TRL Major Node for HSAS Stack

The following sample shows the TRL major node configuration for the HSAS stack:

```
TRL4902 VBUILD TYPE=TRL
MPC4902 TRLE LNCTL=MPC,MAXBFRU=9,REPLYTO=3,
          READ=(4902),
          WRITE=(4903)                                            X
                                                                X
```

In this TRL major node example, the parameter *MPC4B02* must be identical to the oeifconfig statement in the TCP/IP profile.

TCP/IP Profile

The following example shows the TCP/IP profile on the host:

```
ARPAGE 5
telnetparms timemark 600 port 23 dbcstransform endtelnetparms
ASSORTEDPARMS NOFWD ENDASSORTEDPARMS
;
DEVICE mpc4900 MPCPTP
LINK MPCPLNK2 MPCPTP mpc4900
;
INCLUDE TODD.MPCP.TCPIP.PROFILES(PORTS)
HOME
  80.80.2.2      MPCPLNK2
GATEWAY
; NETWORK      FIRST      DRIVER      PACKET      SUBNet mask      subnet value
;              HOP        SIZE
80.80.2.1      =          mpcplnk2   4468        host
DEFAULTNET 80.80.2.1 mpcplnk2 4468        0
BEGINVTAM
  ; Define logon mode tables to be the defaults shipped with the latest
  ; level of VTAM
3278-3-E NSX32703 ; 32 line screen - default of NSX32702 is 24 line screen
3279-3-E NSX32703 ; 32 line screen - default of NSX32702 is 24 line screen
3278-4-E NSX32704 ; 48 line screen - default of NSX32702 is 24 line screen
3279-4-E NSX32704 ; 48 line screen - default of NSX32702 is 24 line screen
3278-5-E NSX32705 ; 132 column screen - default of NSX32702 is 80 columns
3279-5-E NSX32705 ; 132 column screen - default of NSX32702 is 80 columns
  ; Define the LUs to be used for general users
DEFAULTAPPL ECHOMVSF
; DEFAULTAPPL NETTMVSE
DEFAULTLUS
  TCPF0000..TCPF9999
ENDDEFAULTLUS
  ALLOWAPPL * ; Allow all applications that have not been previously
              ; specified to be accessed
ENDVTAM
DATASETPREFIX TODD.MPCP

START mpc4900
```

In this TCP/IP profile, the DEVICE specifies the VTAM TRLE `mpc4900` and LINK specifies the link name (MPCPLNK2) associated with the IP address (80.8.2.2) for that link. The IP address 80.80.2.1 must be identical to the IP address specified for the TG in the router configuration.

HSAS Stack Configuration

The following example shows the OE commands for the HSAS stack configuration:

```
oeifconfig mpc4902 80.80.2.3 80.80.2.1 mtu 4468
oeroute add default 80.80.2.1
```

In this configuration, `mpc4902` must be identical to the TRLE parameter in the `oeifconfig` configuration.

CMPC+ TG Using Two Interfaces Example

Figure 293 illustrates CMPC+ used between a Cisco router with a CIP and a host with split TGs.



Note

The split TG configuration is only supported on a CIP with two physical interfaces.

Figure 293 CMPC+ with Split TG

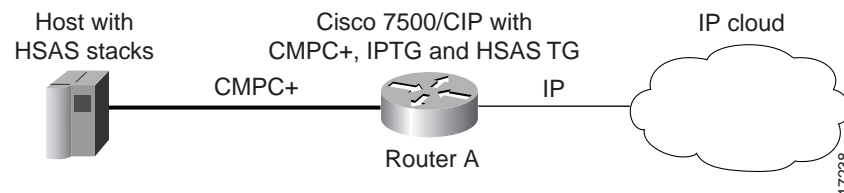

Router

The following example shows the CMPC+ router configuration for a split transmission group:

```
interface Channel0/0
no ip address
no ip directed-broadcast
no keepalive
cmpc 0170 00 TG00 READ
!
interface Channel0/1
no ip address
no ip directed-broadcast
no keepalive
cmpc 0170 00 TG00 WRITE
!
interface Channel0/2
ip address 80.12.165.1 255.255.255.0
no ip redirects
no ip directed-broadcast
ip route-cache same-interface
no ip mroute-cache
load-interval 30
no keepalive
tg TG00      hsas-ip 80.12.165.2 80.12.165.1
!
```

HSAS Configuration

The following example shows the HSAS configuration on the Host:

```
oeifconfig mpcsplit 80.12.165.2 80.12.165.1 mtu 4468
oeroute add default 80.12.165.1
```

TRL Major Node for HSAS Stack

The following example shows the TRL major node configuration for the HSAS stack:

```
TRLSPLIT VBUILD TYPE=TRL
MPCSPLIT TRLE LNCTL=MPC,MAXBFRU=16,REPLYTO=3, X
READ=(5200), X
WRITE=(4B00)
```

In this TRL major node example, the parameter *mpcsplit* must be identical to the TRLE parameter in the LINK statement within the *oeifconfig* statement.