



Managing Dial Shelves

This chapter discusses configuration and monitoring tasks for dial shelves and dial shelf controllers, particularly on Cisco AS5800 Universal Access Servers.

For more information on the Cisco AS5800, go to the Cisco Connection Documentation site on Cisco Connection Online (CCO), or use the Cisco Documentation CD-ROM, and follow this path:

Cisco Product Documentation: Access Servers and Access Routers: Access Servers: Cisco AS5800

For additional information about the technologies in this chapter, see the following publications:

- *Dial and System Management Commands for the Cisco AS5800*
(This document is available online only.)
- *Cisco AS5800 Access Server Software ICG*
- *Cisco IOS Dial Solutions Configuration Guide and Command Reference* (Release 12.1)

For a complete description of dial shelf management commands in this chapter, refer to the “Dial Shelf Management Commands” chapter in the “Cisco IOS System Management Commands” part of the Release 12.1 *Cisco IOS Configuration Fundamentals Configuration Command Reference*. To locate documentation of other commands that appear in this chapter, use the command reference master index or search online.

Dial Shelf Management Task List

Perform the tasks found in the following sections to manage dial shelves:

- Understanding Shelf Architecture and DSIP
- Maintaining Shelves
- Maintaining Dial Shelf Controllers
- Troubleshooting Using DSIP

Understanding Shelf Architecture and DSIP

The Cisco AS5800 is a rack-mounted system consisting of a router shelf and a dial shelf. The dial shelf contains trunk cards, modem cards, and dial shelf controller (DSC) cards. The trunk cards and modem cards are referred to collectively as feature boards. Slots 0 through 11 of the dial shelf are reserved for

feature boards, while slots 12 and 13 are reserved for the DSC cards. The AS5800 series supports the use of a single router shelf or two router shelves (split-shelf configuration), and the use of a single DSC or two DSCs (DSC redundancy) for backup purposes.

Dial Shelf Interconnect Protocol (DSIP) is used for communication between router shelf and dial shelf on an AS5800. Figure 33 diagrams the components of the architecture. DSIP communicates over the packet backplane via the dial shelf interconnect (DSI) cable.

Figure 33 DSIP Architecture in the Cisco AS5800

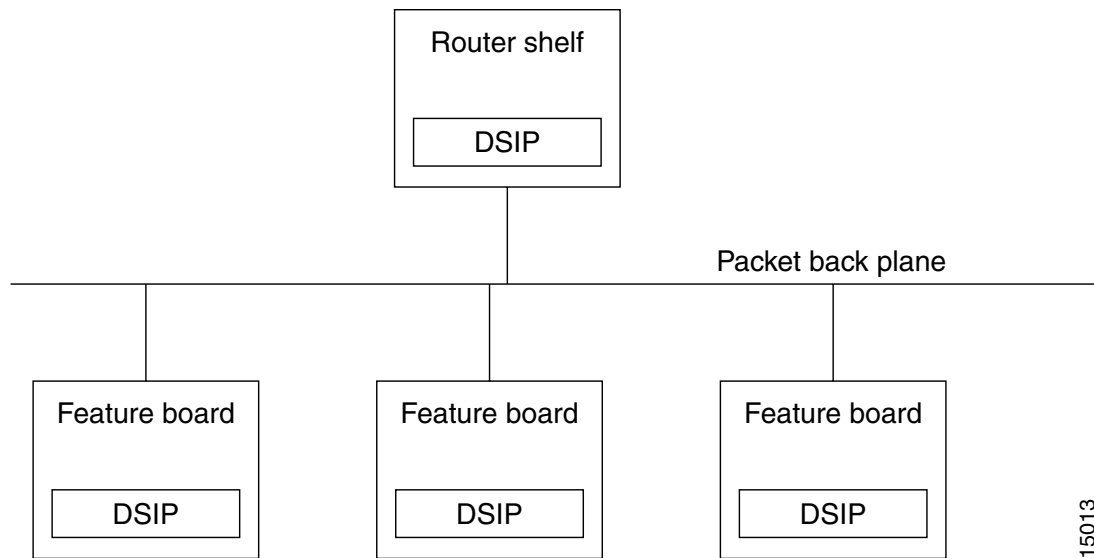

15013

Maintaining Shelves

Perform the tasks described in the following sections to perform the respective configuration tasks:

- Configuring the Shelf IDs
- Executing Commands Remotely

Configuring the Shelf IDs

The Cisco AS5800 consists of one or more router shelves and a dial shelf. Shelf ID numbers and port numbers are used to identify specific components in your system. The default shelf number is 0 for the router shelf and 1 for the dial shelf.

Normally you do not need to change the shelf IDs; however, if you do, we recommend that you change the shelf number when you initially access the setup facility. For information on the setup facility, refer to the *Cisco AS5800 Universal Access Server Software Installation and Configuration Guide*.



Caution

You must reload the Cisco AS5800 for the new shelf number to take effect. Because the shelf number is part of the interface names when you reload, all NVRAM interface configuration information is lost.

If you are booting the router shelf from the network (netbooting), you can change the shelf numbers using the **shelf-id** command. Perform the following tasks beginning in EXEC mode:

	Command	Purpose
Step 1	<code>copy startup-configure tftp</code>	Saves your current configuration. Changing the shelf number removes all interface configuration information when you reload the Cisco AS5800.
Step 2	<code>configure terminal</code>	Enters configuration mode.
Step 3	<code>shelf-id number router-shelf</code>	Specifies the router shelf ID.
Step 4	<code>shelf-id number dial-shelf</code>	Specifies the dial shelf ID.
Step 5	<code>exit</code>	Exits configuration mode.
Step 6	<code>copy running-config startup-config</code>	Saves your configuration. This step is Optional.
Step 7	<code>show version</code>	Verifies that the correct shelf number will be changed after the next reload.
Step 8	<code>reload</code>	Reloads the Cisco AS5800.
Step 9		Type “yes” to the “save config” prompt.
Step 10		Configure one interface so that router shelf has connectivity to the server with the configuration.
Step 11	<code>copy tftp startup-config</code>	Because changing the shelf number removes all interface configuration information when you reload the Cisco AS5800, edit the configuration file saved in step 1 and download it.

If you are booting the router shelf from Flash memory, perform the following tasks beginning in EXEC mode:

	Command	Purpose
Step 1	<code>copy running-config tftp</code> or <code>copy startup-config tftp</code>	Saves your current (latest) configuration to a server.
Step 2	<code>configure terminal</code>	Enters configuration mode.
Step 3	<code>shelf-id number router-shelf</code>	Configures the router shelf ID.
Step 4	<code>shelf-id number dial-shelf</code>	Configures the dial shelf ID.
Step 5	<code>exit</code>	Exits configuration mode.
Step 6	<code>copy running-config startup-config</code>	Saves your configuration. This step is Optional. If this step is skipped, type “No” to the ‘save configuration’ prompt.
Step 7	<code>show version</code>	Allows verification that the correct shelf number will be changed after the next reload.
Step 8		Edit the configuration file saved in Step 1.

	Command	Purpose
Step 9	<code>copy tftp startup-config</code>	Copies the edited configuration to NVRAM on the Cisco AS5800.
Step 10	<code>reload</code>	Reloads the system.

Executing Commands Remotely

It is possible to connect directly to the system console interface on the DSC to execute dial shelf configuration commands, but this is not recommended. All commands necessary for dial shelf configuration, including show and debug tasks, can be executed remotely through the router console. A special command called **execute-on** is provided for this purpose. This command enables a special set of Exec mode commands to be executed on the router or the dial shelf. This command is a convenience that avoids connecting the console to the DSC. For a list of commands you can execute using **execute-on**, see the complete command description in the Release 12.1 *Cisco IOS Configuration Fundamentals Command Reference*.

To enter a command that you wish to execute on a specific card installed in the dial shelf while logged onto the router shelf console, use the following privileged EXEC mode commands:

Command	Purpose
<code>execute-on slot slot command</code>	Executes a command from the router shelf on a specific card in the dial shelf.
<code>execute-on all command</code>	Executes a command from the router shelf on all cards in the dial shelf.

Maintaining Dial Shelf Controllers

The DSC card provides the following:

- Master clock for the dial shelf
- Fast ethernet link to the router shelf
- Environmental monitoring of the feature boards
- Bootstrap images on start-up for the feature boards

The Cisco AS5800 dial shelf can contain two DSC cards. With two DSC cards present, DSC redundancy automatically provides for one DSC to act as a backup to the active one. This redundancy feature is implemented to increase system availability by preventing loss of service in the event of the failure of one of the DSCs. The redundancy is intended to be transparent to most Cisco AS5800 software (redundancy is supported at or below the DSIP layer). Software modules using the DSIP services are generally not aware of nor need to take part in the management of dual DSCs.

Configuring Clocks

The TDM bus in the backplane on the dial shelf must be synchronized to the T1/E1 clocks on the trunk cards. The Dial Shelf Controller (DSC) card on the dial shelf provides hardware logic to accept multiple clock sources as input and use one of them as the primary source to generate a stable, PPL synchronized output clock. The input clock can be any of the following sources:

- Trunk port in slots 0 through 5—up to 12 can be selected (2 per slot)
- An external T1 or E1 clock source fed directly through a connector on the DSC card
- A free-running clock from an oscillator in the clocking hardware on the DSC card

For dual (redundant) DSC cards, the external DSC clocking port should be configured so that the clock signal fed into both DSCs is identical.

To configure the clock source and priority of the clock source used by the TDM bus, perform one or more of the following tasks, beginning in global configuration mode:

	Command	Purpose
Step 1	<code>dial-tdm-clock priority number trunk-slot slot port number</code>	Configure the priority of the trunk card clock.
Step 2	<code>dial-tdm-clock priority number freerun</code>	Configure the priority of the free running clock.
Step 3	<code>dial-tdm-clock priority number external {e1 t1} [120ohm]</code>	Configure the priority of the T1 or E1 external clock.
Step 4	<code>exit</code>	Exit configuration mode.
Step 5	<code>copy running-config startup-config</code>	Save your configuration.
Step 6	<code>show dial-shelf clocks</code>	Verify the clocking priorities.

Monitoring and Maintaining DSCs and Feature Boards

Use the following commands in privileged EXEC mode to swap dial shelf cards or to troubleshoot the dial shelf cards from the router shelf:

Command	Purpose
<code>hw-module slot shelf-id/slot-number {start stop}</code>	Stops a DSC remotely from the router console or restarts the DSC if it has been stopped.
<code>hw-module slot shelf-id/slot-number reload</code>	Reloads the specified feature board. This command can be used instead of a manual online insertion and removal (OIR) to reload and powercycle a feature board. Note that this command cannot be applied to DSCs.
<code>show redundancy [history]</code>	Displays the current or history status for redundant DSC.
<code>debug redundancy {all ui clk hub}</code>	Use this debug command if you need to collect events for troubleshooting, selecting the appropriate required key word.
<code>show debugging</code>	Lists the debug commands that are turned on, including that for redundant DSC.

Troubleshooting Using DSIP

There are a number of show commands available to aid in troubleshooting Dial Shelves. Use any of the following EXEC mode commands to monitor DSI and DSIP activity:

Command	Purpose
<code>clear dsip tracing</code>	Used to clear tracing statistics for the Distributed System Interconnect Protocol (DSIP).
<code>show dsip</code>	Displays all information about the Distributed System Interconnect Protocol (DSIP).
<code>show dsip clients</code>	Displays information about Distributed System Interconnect Protocol (DSIP) clients.
<code>show dsip nodes</code>	Displays information about the processors running the Distributed System Interconnect Protocol (DSIP).
<code>show dsip ports</code>	Displays information about local and remote ports.
<code>show dsip queue</code>	Displays the number of messages in the retransmit queue waiting for acknowledgment.
<code>show dsip tracing</code>	Displays Distributed System Interconnect Protocol (DSIP) tracing buffer information.
<code>show dsip transport</code>	Displays information about the Distributed System Interconnect Protocol (DSIP) transport statistics for the control/data and IPC packets and registered addresses.
<code>show dsip version</code>	Displays Distributed System Interconnect Protocol (DSIP) version information.

The privileged EXEC mode **show dsi** command can also be used to troubleshoot, as it displays the status of the DSI adapter, which is used to physically connect the router shelf and the dial shelf to enable DSIP communications.

The following is an example troubleshooting scenario:

Problem: The router shelf boots, but there is no communication between the router and dial shelves.

-
- Step 1** Run the **show dsip transport** command.
 - Step 2** Check the “DSIP registered addresses” column. If there are zero entries here, there is some problem with the Dial Shelf Interconnect (DSI). Check if the DSI is installed in the router shelf.
 - Step 3** If there is only one entry and it is our own local address, then first sanity check the physical layer. Make sure that there is a physical connection between the RS and DS. If everything is fine from cabling point of view, go to step 3.
 - Step 4** Check the DSI health by issuing the **show dsi** command. This gives a consolidated output of DSI controller and interface. Check for any errors like runts, giants, throttles and other usual FE interface errors.
-

Diagnosis: If an entry for a particular dial shelf slot is not found among the registered addresses, but most of other card entries are present, the problem is most likely with that dial shelf slot. The DSI hardware on that feature board is probably bad.