



# MGCP CAS PBX and AAL2 PVC

---

## Feature History

Release	Modification
12.1(5)XM	This feature was introduced on the Cisco 1750 modular access router, Cisco 2600 series access routers, Cisco 3600 series multiservice platforms, Cisco AS5300 universal access server, Cisco MC3810 series multiservice access concentrators, and Cisco uBR924 cable access router.

This feature module describes the Media Gateway Control Protocol (MGCP) CAS PBX and AAL2 PVC software features, and includes:

- [Feature Overview, page 2](#)
- [Supported Platforms, page 6](#)
- [Supported Standards, MIBs, and RFCs, page 7](#)
- [Prerequisites, page 7](#)
- [Configuration Tasks, page 8](#)
- [Configuration Examples, page 12](#)
- [Command Reference, page 45](#)
- [Glossary, page 100](#)

# Feature Overview

The MGCP CAS PBX and AAL2 PVC features extend the earlier Simple Gateway Control Protocol (SGCP) Channel Associated Signaling (CAS) and AAL2 support onto the merged SGCP/MGCP software base to enable various service provider solutions.

## MGCP CAS PBX and AAL2 PVC Features

- CAS termination and translation to MGCP on Business Gateways (BGWs) and Trunking Gateways (TGWs).

Digital CAS (E&M) interfaces are supported in addition to the analog (FXO, FXS, and E&M) interfaces.

- Support for CAS PBX and Feature Group D CAS Functions.

MGCP 0.1 has been expanded to support CAS packages that handle CAS PBX and Feature Group D CAS functions, including Barge-In/Busy Line Verify, and 911 capabilities on the TGW.

- Expanding MGCP 0.1 to control AAL2 voice transport.

The earlier version of the merged SGCP/MGCP stack supported only Voice over IP. The merged stack will now support both VoIP and VoAAL2.

Only the Cisco MC3810 series platforms supports this feature in this release.

- Addition of SGCP CAS PBX support to the existing merged SGCP/MGCP software stack.

The CAS PBX gateway features include CAS PBX trunks, digit maps, CAS events, and quarantine buffer software. These features were available in the existing standalone SGCP software; now they are supported in the merged stack.

- Consolidation of various SGCP and MGCP feature sets onto one software image for Residential Gateways (RGWs), BGWs, and TGWs.

The essential difference for current SGCP users is that support for the SGCP application has been replaced with the MGCP application. The MGCP application supports both SGCP commands and MGCP commands, permitting access to a larger feature set than with the SGCP application alone. The MGCP CAS PBX and AAL2 PVC software assumes the MGCP mode as the default environment. This allows the gateway to recognize both MGCP and SGCP messages sent by the call agent. However, the user can specify SGCP mode for certain messages that will be sent by the gateway (by using the **sgcp** option as the service type in the **mgcp call-agent** command).

**Examples of Service Provider Solutions**

MGCP CAS PBX and AAL2 PVC features support several types of service provider solutions:

- Residential cable access

A CLEC can use residential cable access to provide residential customers with basic telephony and data services. Figure 1 illustrates a possible residential cable access solution:

**Figure 1 Residential Cable Access Solution**

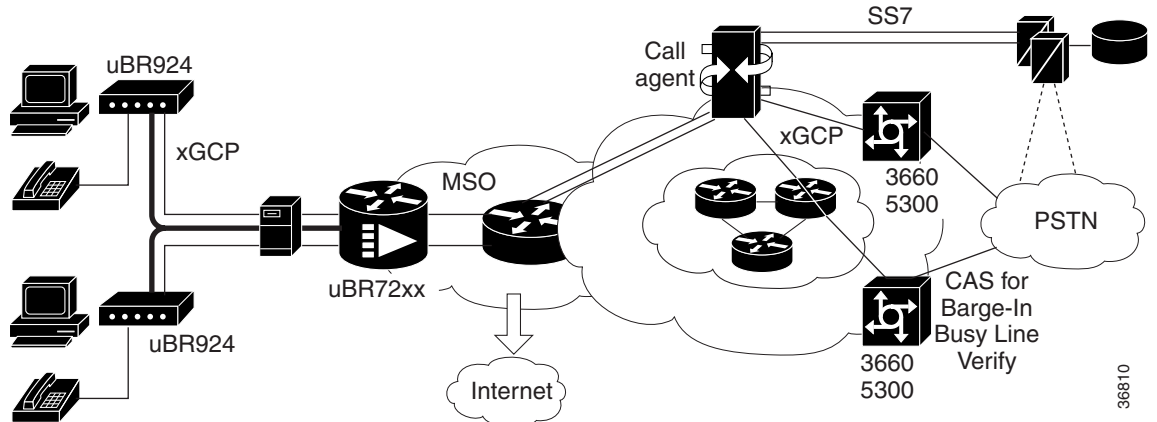

Note that in Figure 1, the trunking gateway (the Cisco 3660 platform) requires support of incoming and outgoing MF signaling for the Barge-In and Busy-Line Verify features. The residential gateway (the Cisco uBR924 cable access router) must support the CLASS features and 911 capability.

- IP Centrex and IP PBX

In these solutions, a call agent provides business voice services traditionally offered by a circuit-based PBX. Figure 2 illustrates an IP Centrex solution:

**Figure 2 IP Centrex Solution**

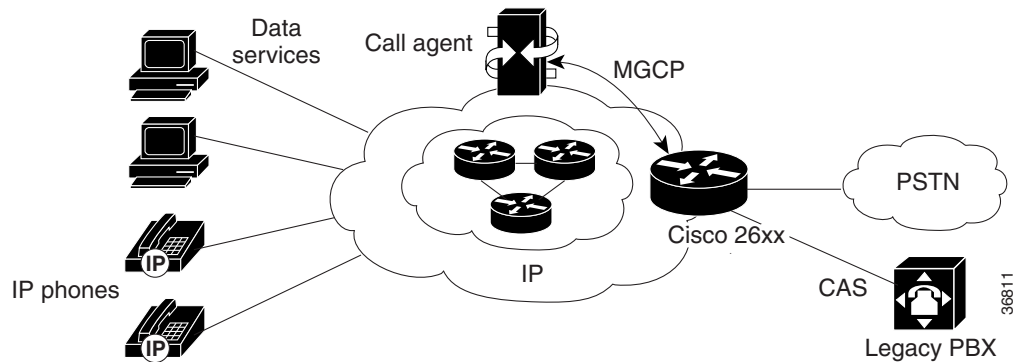

In Figure 2, the BGW (the Cisco 2600 platform) requires PBX connectivity to interface with the legacy PBX.

- Integrated Access

A CLEC or IXC can provide small, medium, and large businesses with integrated voice and data access services. The integrated access device can be located at the central office or on the customer's premises. Access to the subscriber can be analog or digital T1 interfaces in addition to DSL. Transport of voice and data can be over IP, Frame Relay, or ATM. Figure 3 illustrates an integrated access solution:

**Figure 3 Integrated Access Solution**

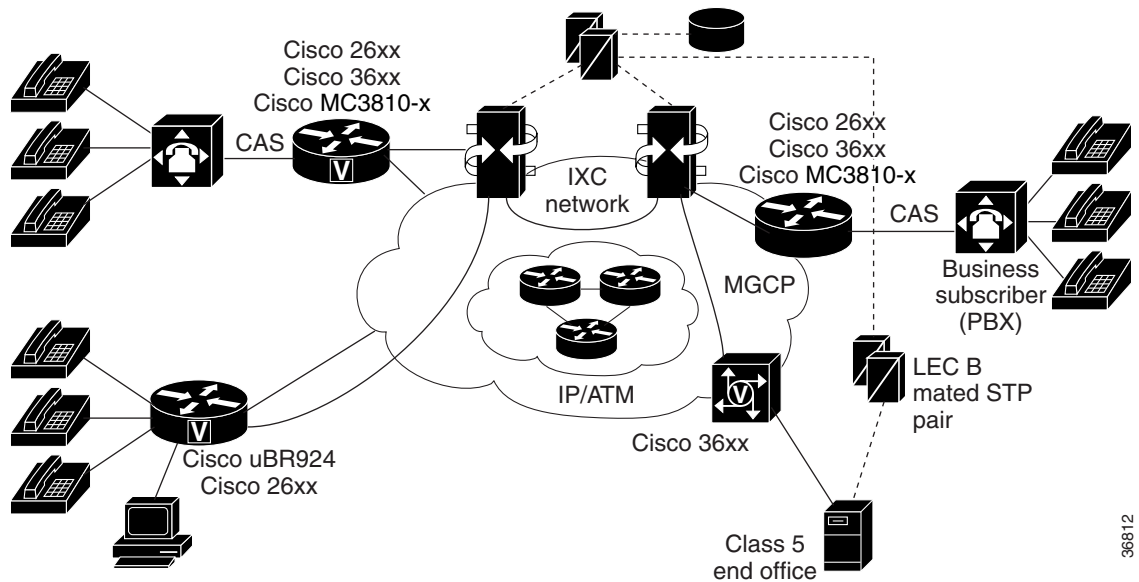

In Figure 3, MGCP control of calls over the AAL2 PVCs is required on the BGWs (the Cisco 2600 series, Cisco 3600, and Cisco 3810 series platforms) to connect into the ATM network for VToA.

- Telecommuter or Small Office-Home Office (SOHO)

Figure 4 illustrates a telecommuter/small office-home office solution:

**Figure 4 Telecommuter or Small Office-Home Office Solution**

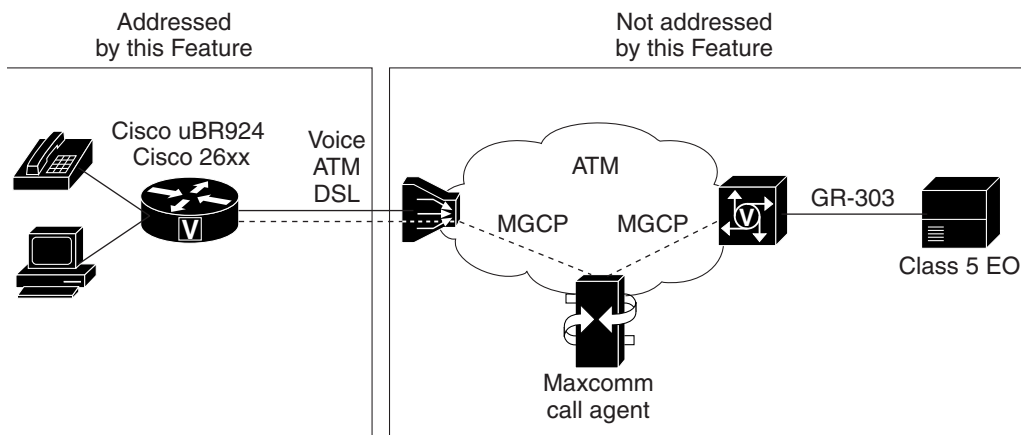

In Figure 4, MGCP must control the calls over AAL2 PVCs, and an analog FXS interface is required.

36812

36813

## Benefits

- The merged SGCP/MGCP software for RGWs, BGWs, and TGWs enables easier development and growth of Cisco and customer solutions.
- MGCP CAS PBX and AAL2 PVC software meets customer requirements for CAS connectivity to traditional PBXs and regulatory requirements for support of 911, Barge In, and Busy Line Verify features.

## Restrictions

### MGCP CAS PBX and AAL2 PVC Software Caveats

- Only the Cisco MC3810 series platform supports MGCP 0.1 control of AAL2 voice transport in this Cisco IOS release.
- For the Cisco MC3810 series platform, the AAL2 PVC functionality is supported on the HCM version of the DSP card; it is not supported on the VCM version.

To check the type of DSP card, enter a **show version** command at the EXEC prompt. For example:

```
Router# show version
```

- If you have an HCM card, the following line appears as part of the **show version** information:

```
1 6-DSP (slot 2) High Performance Compression Module(v01.A0)
```

- If you have a VCM card, the following line appears as part of the **show version** information:

```
1 6-DSP (slot 2) Voice Compression Module(v255.V7)
```

If you have the HCM card, the MGCP BCOS features will function correctly. If you have the VCM card, the AAL2 PVC feature is not supported.

- The Cisco AS5300 multiservice platform supports only the FGD-OS Barge-In/Busy Line Verify and 911 features of the MGCP CAS PBX and AAL2 PVC software.

### Features Not Supported

Basic CLASS and Operator features are covered in the MGCP Basic CLASS and Operator Services software. For more information on these capabilities, refer to *MGCP Basic CLASS and Operator Services* at

[http://www.cisco.com/univercd/cc/td/doc/product/software/ios121/121newft/121limit/121x/121xm/121xm\\_5/ftmgcpga.htm](http://www.cisco.com/univercd/cc/td/doc/product/software/ios121/121newft/121limit/121x/121xm/121xm_5/ftmgcpga.htm)

- The MGCP CAS PBX and AAL2 PVC software has not implemented DSP clock slotting changes, Comfort Noise Indication, ATM SVCs, TGCP, AAL1, FXO support in SGCP, ATM on the Cisco 3660 platform, and VoIP Call Admission Control (CAC). These capabilities are part of other Cisco development efforts.

## Related Features and Technologies

Voice over IP (VoIP)

## Related Documents

General reference documents:

- Cisco IOS Multiservice Applications Command Reference  
[http://www.cisco.com/univercd/cc/td/doc/product/software/ios121/121cgcr/multi\\_r/index.htm](http://www.cisco.com/univercd/cc/td/doc/product/software/ios121/121cgcr/multi_r/index.htm)
- *Cisco IOS Multiservice Applications Configuration Guide*  
[http://www.cisco.com/univercd/cc/td/doc/product/software/ios121/121cgcr/multi\\_c/index.htm](http://www.cisco.com/univercd/cc/td/doc/product/software/ios121/121cgcr/multi_c/index.htm)

Feature documents:

- *MGCP Basic CLASS and Operator Services*  
[http://www.cisco.com/univercd/cc/td/doc/product/software/ios121/121newft/121limit/121x/121xm/121xm\\_5/ftmgcpga.htm](http://www.cisco.com/univercd/cc/td/doc/product/software/ios121/121newft/121limit/121x/121xm/121xm_5/ftmgcpga.htm)
- *Media Gateway Control Protocol Residential Gateway Support*  
<http://www.cisco.com/univercd/cc/td/doc/product/software/ios121/121newft/121t/121t3/mgcp1213.htm>
- *Voice Over ATM with AAL2 Trunking on Cisco MC3810 Series Concentrators*  
[http://www.cisco.com/univercd/cc/td/doc/product/software/ios121/121newft/121limit/121x/121xa/121xa\\_1/aal2\\_fm.htm](http://www.cisco.com/univercd/cc/td/doc/product/software/ios121/121newft/121limit/121x/121xa/121xa_1/aal2_fm.htm)
- *Simple Gateway Control Protocol Support for the Cisco MC3810 and Cisco 3600 Series Routers*  
[http://www.cisco.com/univercd/cc/td/doc/product/software/ios120/120newft/120limit/120xk/1207xk/sgcp\\_6xk.htm](http://www.cisco.com/univercd/cc/td/doc/product/software/ios120/120newft/120limit/120xk/1207xk/sgcp_6xk.htm)

Product documents:

- *Cisco uBR924 Software Configuration Guide*  
[http://www.cisco.com/univercd/cc/td/doc/product/cable/cab\\_modm/ubr924/scg924/index.htm](http://www.cisco.com/univercd/cc/td/doc/product/cable/cab_modm/ubr924/scg924/index.htm)
- *Software Configuration Documents for the Cisco 2600*  
[http://www.cisco.com/univercd/cc/td/doc/product/access/acs\\_mod/cis2600/sw\\_conf/index.htm](http://www.cisco.com/univercd/cc/td/doc/product/access/acs_mod/cis2600/sw_conf/index.htm)
- *Software Configuration Documents for the Cisco 3600*  
[http://www.cisco.com/univercd/cc/td/doc/product/access/acs\\_mod/cis3600/sw\\_conf/index.htm](http://www.cisco.com/univercd/cc/td/doc/product/access/acs_mod/cis3600/sw_conf/index.htm)
- *Cisco 1750 Voice-Over-IP Software Configuration Guide*  
[http://www.cisco.com/univercd/cc/td/doc/product/access/acs\\_mod/1700/1750/1750voip/index.htm](http://www.cisco.com/univercd/cc/td/doc/product/access/acs_mod/1700/1750/1750voip/index.htm)
- *Cisco AS5300 Software Configuration Guide*  
[http://www.cisco.com/univercd/cc/td/doc/product/access/acs\\_serv/5300/53swcf2/index.htm](http://www.cisco.com/univercd/cc/td/doc/product/access/acs_serv/5300/53swcf2/index.htm)

## Supported Platforms

- Cisco 1750 Modular Access Router
- Cisco 2600 Series Modular Access Routers
- Cisco 3620, 3640, and 3660 Multiservice Platforms
- Cisco AS5300 Multiservice Platform
- Cisco MC3810 Series Multiservice Access Concentrator
- Cisco uBR924 Cable Access Router

Supported codecs:

- G711alaw
- G711ulaw

- G723a
- G723r
- G726r
- G729a
- G729b
- G729r

## Supported Standards, MIBs, and RFCs

### Standards

- RTP and RTCP 1889 and 1890
- IETF MGCP draft version 0.1 dated November 9, 1998

### MIBs

#### XGCP-MIB

To obtain lists of supported MIBs by platform and Cisco IOS release, and to download MIB modules, go to the Cisco MIB website on Cisco.com at the following URL:

<http://www.cisco.com/public/sw-center/netmgmt/cmtk/mibs.shtml>

### RFCs

SDP 2327 is not completely implemented.

## Prerequisites

Complete the following tasks before configuring this feature:

- Configure IP routing

For more information on IP routing, refer to *Cisco IOS IP and IP Routing Configuration Guide* at:

[http://www.cisco.com/univercd/cc/td/doc/product/software/ios121/121cgcr/ip\\_c/index.htm](http://www.cisco.com/univercd/cc/td/doc/product/software/ios121/121cgcr/ip_c/index.htm)

- Configure voice ports

For more information on configuring voice ports, refer to *Cisco IOS Multiservice Applications Configuration Guide* at:

[http://www.cisco.com/univercd/cc/td/doc/product/software/ios121/121cgcr/multi\\_c/index.htm](http://www.cisco.com/univercd/cc/td/doc/product/software/ios121/121cgcr/multi_c/index.htm)

- Configure Voice over IP

For more information, refer to *Cisco IOS Multiservice Applications Configuration Guide* at:

[http://www.cisco.com/univercd/cc/td/doc/product/software/ios121/121cgcr/multi\\_c/index.htm](http://www.cisco.com/univercd/cc/td/doc/product/software/ios121/121cgcr/multi_c/index.htm)

- Set up the call agent or call agents

For more information on setting up call agents, refer to the documentation that accompanies the call agents used in your network configuration.

Refer to “Restrictions” section on page 5 for additional prerequisite activities for the platforms in your configurations.

# Configuration Tasks

See the following sections for configuration tasks for the MGCP CAS PBX and AAL2 PVC feature. Each task in the list indicates if the task is optional or required.

- [Configuring the Gateway, page 8](#)
- [Configuring Subcell Multiplexing for AAL2 Voice, page 11](#)
- [Configuring the Cisco uBR924 Cable Access Router for SGCP and MGCP Functionality, page 11](#)

Some tasks indicate one or more configuration examples affected by the command. Refer to the specific configuration example listing for the parameter values.

## Configuring the Gateway

	Command	Purpose
Step 1	Router(config)# <b>mgcp</b>	<i>(Required)</i> Starts the MGCP daemon.
Step 2	Router(config)# <b>mgcp call-agent</b> {ipaddr   hostname} [port] [ <b>service-type</b> type] <b>version</b> version-number	<i>(Required)</i> Configures the MGCP call agent and service type. If you want SGCP mode, use <b>sgcp</b> as the service type.
Step 3	Router(config)# <b>mgcp dtmf-relay voip codec</b> {all   low-bit-rate} <b>mode</b> {cisco   nse   out-of-band}	<i>(Optional. See Configuration Example 2.)</i> Specifies compressed codecs for digit forwarding.
Step 4	Router(config)# <b>mgcp package-capability</b> {as-package   atm-package   dtmf-package   gm-package   hs-package   nas-package   rtp-package   script-package   trunk-package}	<i>(Optional. See Configuration Example 2.)</i> Assigns packages to the gateway. Also refer to the <b>mgcp default-package</b> command.
Step 5	Router(config-if)# <b>mgcp sgcp restart notify</b>	<i>(Required only for SGCP mode with a call agent supporting RSIP. See Configuration Examples 4 through 9.)</i> Causes MGCP to send SGCP RSIP messages.
Step 6	Router(config-if)# <b>mgcp modem passthrough</b> [voip   voaal2] <b>mode</b> [cisco   nse]	<i>(Optional for nse mode)</i> Enables the gateway to process fax or modem messages. VoAAL2 does not support <b>cisco</b> .
Step 7	Router(config)# <b>mgcp tse payload</b> type	<i>(Required for nse mode. See Step 6.)</i> Enables the TSE payload for fax and modem messages.
Step 8	Router(config)# <b>mgcp rtp unreachable timeout</b> timer-value	<i>(Optional)</i> Enables detection of unreachable remote VoIP endpoints.
Step 9	Router(config)# <b>no mgcp timer receive-rtcp</b>	<i>(Required for non-RGWs. See Configuration Examples 2 through 9.)</i> Turns off the RTP RTCP receive timeout interval at the gateway.
Step 10	Router(config)# <b>mgcp timer net-cont-test</b> timer	<i>(Optional for non-RGWs. See Configuration Examples 2 through 9.)</i> Turns on the continuity test timeout interval at the gateway.
Step 11	Router(config)# <b>controller T1 0</b>	<i>(Required for ATM mode. See Configuration Examples 2 through 9.)</i> Selects the T1 controller 0.

	Command	Purpose
Step 12	Router(config-controller)# <b>mode atm</b>	<p>(Required for ATM mode. See Configuration Examples 2 through 9.) Specifies that the controller will support ATM encapsulation and create ATM interface 0.</p> <p>When the controller is set to ATM mode, the following takes place:</p> <ul style="list-style-type: none"> <li>• Controller framing is automatically set to Extended SuperFrame (ESF).</li> <li>• The linecode is automatically set to B8ZS.</li> </ul>
Step 13	Router(config-controller)# <b>no shutdown</b>	(Optional for ATM mode. See Configuration Examples 2 through 9.) Ensures that the controller is activated.
Step 14	Router(config-controller)# <b>exit</b>	(Required for ATM mode. See Configuration Examples 2 through 9.) Exits the controller configuration mode.
Step 15	Router(config)# <b>mgcp quarantine mode process</b>	(Optional) Turns on processing for SGCP quarantine mode.
Step 16	Router(config)# <b>controller T1 1</b>	(Required for CAS PBX. See Configuration Examples 3, 4, and 5.) Select the T1 controller 1.
Step 17	Router(config-controller)# <b>mode cas</b>	(Required for CAS PBX. See Configuration Examples 3, 4, and 5.) Specify that the controller will support CAS.
Step 18	Router(config-controller)# <b>ds0-group channel-number timeslots range type signaling-type tone type addr info service service-type</b>	<p>(Required for CAS PBX. See Configuration Examples 3, 4, and 5.) Configure the T1 timeslots for CAS calls. The scenarios use the following three DS-0 definitions:</p> <ul style="list-style-type: none"> <li>• ds0-group 1 timeslots 1-8 type e&amp;m-immediate-start</li> <li>• ds0-group 2 timeslots 9-16 type e&amp;m-wink-start</li> <li>• ds0-group 3 timeslots 17-24 type fxs-ground-start</li> </ul>
Step 19	Router(config-controller)# <b>exit</b>	(Required for CAS PBX. See Configuration Examples 3, 4, and 5.) Exit controller configuration mode.
Step 20	Router(config)# <b>interface atm0</b> [subinterface-number [multipoint   point-to-point]]	<p>(Required for ATM mode. See Configuration Examples 2 through 9.) Enter interface configuration mode to configure ATM interface 0 or an ATM subinterface.</p> <p>The default for subinterfaces is <b>multipoint</b>.</p> <p>For all Scenarios: Set up three subinterfaces for point-to-point.</p>
Step 21	Router(config-if)# <b>pvc</b> [name] vpi/vci	<p>(Required for ATM mode. See Configuration Examples 2 through 9.) Create an ATM PVC for voice traffic and enter ATM virtual circuit configuration mode.</p> <p><b>Note</b> The <b>ilmi</b> and <b>qsaal</b> options are not supported for AAL2.</p>

Command	Purpose
<b>Step 22</b> Router(config-if-atm-vc) # <b>encapsulation aal-encap</b>	<p>(Required for ATM mode. See Configuration Examples 2 through 9.) Set the encapsulation of the PVC for voice traffic. <b>aal2</b> automatically creates channel identifiers (CIDs) 1 through 255.</p> <p>Some of the Scenarios use <b>aal5snap</b> for ATM0.1 and ATM0.3. Use <b>aal2</b> for ATM0.2.</p>
<b>Step 23</b> Router(config-if-atm-vc) # <b>vbr-rt peak-rate average-rate [burst]</b>	<p>(Required for ATM mode. See Configuration Examples 2 through 9.) Configures the PVC for the variable-bit-rate real-time (voice) traffic. Guidelines for setting the peak rate, average rate, and burst size are as follows:</p> <ul style="list-style-type: none"> <li>• Peak rate: If it does not exceed your carrier's allowable rate, set to the line rate (for example, 1536 kbps for T1-ATM).</li> <li>• Average rate: Calculate according to the maximum number of calls the PVC will carry times the bandwidth per call. The following formulas give you the average rate in kbps: <ul style="list-style-type: none"> <li>for VoIP: <ul style="list-style-type: none"> <li>– G.711 with 40 or 80 byte sample size: max calls x 128K</li> <li>– G.726 with 40 byte sample size: max calls x 85K</li> <li>– G.729a with 10 byte sample size: max calls x 85K</li> </ul> </li> <li>for VoAAL2: <ul style="list-style-type: none"> <li>– G.711 with 40 byte sample size: max calls x 85K</li> <li>– G.726 with 40 byte sample size: max calls x 43K</li> <li>– G.729a with 10 byte sample size: max calls x 43K</li> </ul> </li> </ul> </li> </ul> <p>If voice activity detection (VAD) is enabled, the bandwidth usage is reduced by as much as 12 percent with the maximum number of calls in progress. With fewer calls in progress, bandwidth savings are less.</p> <ul style="list-style-type: none"> <li>• Burst size: Set the burst size as large as possible, and never less than the minimum burst size. Guidelines are as follows: <ul style="list-style-type: none"> <li>– The minimum burst size is 4 x the number of voice calls.</li> <li>– The maximum burst size is the maximum allowed by the carrier.</li> </ul> </li> </ul>

	Command	Purpose
Step 24	Router(config-if-atm-vc)# <b>vcci pvc-identifier</b>	(Optional for ATM mode. See Configuration Examples 2 through 9.) Assigns a unique identifier to the PVC.
Step 25	Router(config-if-atm-vc)# <b>exit</b>	(Required for ATM mode. See Configuration Examples 2 through 9.) Exits ATM virtual circuit configuration mode.
Step 26	Router(config-if)# <b>exit</b>	(Required for ATM mode. See Configuration Examples 2 through 9.) Exits interface configuration mode.
Step 27	Router(config)# <b>dial-peer voice number pots</b>	(Required) Enter dial peer configuration mode for the POTS dial peer.
Step 28	Router(config-dial-peer)# <b>application MGCPAPP</b>	(Required) Initiates the MGCP protocol for the voice ports.
Step 29	Router(config-dial-peer)# <b>exit</b>	(Required) Exits dial-peer configuration mode.

## Configuring Subcell Multiplexing for AAL2 Voice

This section describes the configuration tasks necessary to enable AAL2 common part sublayer (CPS) subcell multiplexing when the Cisco MC3810 series platform interoperates with a voice interface service module (VISM) in an MGX switch. For an explanation of these commands, see *Voice over ATM with AAL2 Trunking on Cisco MC3810 Series Concentrators* in Cisco IOS Release 12.1(1)XA at:

[http://www.cisco.com/univercd/cc/td/doc/product/software/ios121/121newft/121limit/121x/121xa/121xa\\_1/aal2\\_fm.htm](http://www.cisco.com/univercd/cc/td/doc/product/software/ios121/121newft/121limit/121x/121xa/121xa_1/aal2_fm.htm)

	Command	Purpose
Step 1	Router(config)# <b>voice service voatm</b>	(Required) Enters voice-service configuration mode.
Step 2	Router(config-voice-service)# <b>session protocol aal2</b>	(Required) Enters voice-service-session configuration mode and specifies AAL2 trunking.
Step 3	Router(config-voice-service-session)# <b>subcell-mux</b>	(Required) Enables subcell multiplexing. By default, subcell multiplexing is not enabled.
Step 4	Router(config-voice-service-session)# <b>end</b>	(Required) Exits configuration mode.

## Configuring the Cisco uBR924 Cable Access Router for SGCP and MGCP Functionality

The Cisco uBR924 cable access router requires standard per-port provisioning to work with MGCP CAS PBX and AAL2 PVC:

To access SGCP functionality, use the command:

```
S|0|ca1@call-agent.abc.com:2427|S|1|ca2@call-agent.abc.com:2427
```

To access MGCP functionality, use the command:

```
M|0|ca1@call-agent.abc.com:2427|M|1|ca2@call-agent.abc.com:2427
```

For either functionality type, port 0 points to call agent 1 and port 1 points to call agent 2. If needed, both ports can point to the same call agent.

## Verifying the MGCP CAS PBX and AAL2 PVC Configurations

Use these commands to verify the configuration settings:

	Command	Purpose
Step 1	Router# <b>show dial-peer voice sum</b>	Displays the status of the dial peer. The dial peer should be active. If it is not, enter the command: Router(config-dial-peer)# <b>no shutdown</b>
Step 2	Router# <b>show running-config</b>	Displays the current configuration settings.

## Monitoring and Maintaining MGCP CAS PBX and AAL2 PVC Configurations

Use these commands at any time to monitor the MGCP configuration:

Command	Purpose
Router# <b>show mgcp</b> [connection   endpoint   statistics]	Displays all active MGCP connections on the router.
Router# <b>debug mgcp</b> [all   errors   events   packets   parser]	Turns on debugging for the gateway.
Router# <b>clear mgcp statistics</b>	Resets the MGCP statistical counters.

## Configuration Examples

This section provides the following configuration diagrams and software examples:

- [Example 1: MGCP Residential Gateway, page 12](#)
- [Example 2: MGCP Gateway using Voice over ATM AAL2, page 14](#)
- [Example 3: MGCP/SGCP E&M Wink-Start, page 15](#)
- [Example 4: SGCP 1.5 CAS PBX using Voice over ATM AAL2, page 17](#)
- [Example 5: SGCP 1.5 CAS PBX using Voice over IP over ATM AAL5, page 22](#)
- [Example 6: SGCP 1.5 Analog E&M PBX using Voice over ATM AAL2, page 27](#)
- [Example 7: SGCP 1.5 Analog E&M PBX using Voice over IP over ATM AAL5, page 32](#)
- [Example 8: SGCP 1.5 RGW using Voice over ATM AAL2, page 36](#)
- [Example 9: SGCP 1.5 RGW using Voice over IP over ATM AAL5, page 40](#)

### Example 1: MGCP Residential Gateway

The following example illustrates the configuration for a Cisco MC3810 series platform with CAS running the MGCP application:

```

version 12.1
no service pad
service timestamps debug datetime msec
service timestamps log uptime
!
```

```
hostname Router
!
logging buffered
!
ip subnet-zero
ip host first 192.168.254.254
!
mgcp
mgcp call-agent 172.16.90.1
!
!
voice-card 0
    codec complexity high
!
!
controller T1 0
    framing esf
    linecode b8zs
!
!
interface Ethernet0
    ip address 172.16.92.3 255.255.0.0
!
interface Serial0
    shutdown
!
interface Serial1
    no ip address
    no ip route-cache
    no ip mroute-cache
    shutdown
!
interface FR-ATM20
    no ip address
    shutdown
!
ip default-gateway 172.16.0.1
ip route 198.168.254.0 255.255.255.0 172.16.0.1
!
!
voice-port 1/1
!
dial-peer voice 1 pots
    application MGCPAPP
    port 1/1
!
!
line con 0
    exec-timeout 0 0
    transport input none
line aux 0
line 2 3
line vty 0 4
    login
!
end
```

## Example 2: MGCP Gateway using Voice over ATM AAL2

The following configuration illustrates a Cisco MC3810 series platform running the MGCP application using ATM AAL2 to carry voice traffic:

```

version 12.1
service timestamps debug uptime
service timestamps log uptime
no service password-encryption
!
hostname main.office
!
network-clock base-rate 56k
ip subnet-zero
no ip domain-lookup
ip host second 192.168.254.254
ip host first 192.168.254.253
!
mgcp
mgcp call-agent 172.16.117.4 service-type mgcp version 0.1
mgcp dtmf-relay voip codec all mode nse
mgcp dtmf-relay voaal2 codec all
mgcp package-capability rtp-package
mgcp tse payload 100
mgcp timer receive-rtcp 100
mgcp timer net-cont-test 3000
isdn voice-call-failure 0
!
!
voice-card 0
!
controller T1 0
mode atm
framing esf
linecode b8zs
!
interface Ethernet0
ip address 171.16.121.1 255.255.0.0
!
interface Serial0
no ip address
no ip mroute-cache
shutdown
no fair-queue
!
interface Serial1
no ip address
shutdown
!
interface ATM0
no ip address
ip mroute-cache
no atm ilmi-keepalive

interface ATM0.2 point-to-point
pvc 2/200
vbr-rt 760 760 100
encapsulation aal2
vcci 2
!
interface FR-ATM20
no ip address
shutdown

```

```

!
router group1 1
  redistribute connected
  network 172.0.0.0
!
ip default-gateway 172.16.0.1
no ip http server
ip classless
ip route 192.168.254.0 255.255.255.0 172.16.0.1
!
dialer-list 1 protocol ip permit
dialer-list 1 protocol ipx permit
voice-port 1/1
  codec g711ulaw
!
voice-port 1/2
  shutdown
!
voice-port 1/6
  shutdown
!
dial-peer voice 1 pots
  application MGCPAPP
  destination-pattern 2220001
  port 1/1
!
!
line con 0
  transport input none
line aux 0
  line 2 3
line vty 0 4
  login
!
end

```

### Example 3: MGCP/SGCP E&M Wink-Start

The following example illustrates an E&M wink-start configuration on the Cisco MC3810 series platform that can be defined for either the SGCP or MGCP modes:

```

version 12.1
no service pad
service timestamps debug datetime msec
service timestamps log datetime msec
no service password-encryption
!
hostname sales
!
!
!
!
network-clock base-rate 56k
ip subnet-zero
!
mgcp
no mgcp timer receive-rtcp
call rsvp-sync
!
voice service voatm
!

```

```

    session protocol aal2
      subcell-mux
    !
    !
    !
    !
  voice-card 0
  !
  !
  !
  controller T1 0
    mode atm
    framing esf
    clock source internal
    linecode b8zs
  !
  controller T1 1
    mode cas
    framing esf
    linecode b8zs
    ds0-group 1 timeslots 1-24 type e&m-wink-start
  !
  !
  !
  !
  interface Ethernet0
    ip address 172.29.248.199 255.255.255.0
    no ip route-cache
    no ip mroute-cache
  !
  interface Serial0
    no ip address
    no ip route-cache
    no ip mroute-cache
  !
  interface Serial1
    no ip address
    no ip route-cache
    no ip mroute-cache
    shutdown
  !
  interface ATM0
    no ip address
    ip mroute-cache
    no atm ilmi-keepalive
  !
  interface ATM0.2 point-to-point
    pvc 2/200
    vbr-rt 1536 1536 100
    encapsulation aal2
    vcci 10
  !
  !
  interface FR-ATM20
    no ip address
    no ip route-cache
    shutdown
  !
  ip classless
  ip route 0.0.0.0 0.0.0.0 172.29.248.1
  no ip http server
  !
  !
  !

```

```

voice-port 1:1
 dial-type mf
 !
dial-peer cor custom
 !
 !
 !
dial-peer voice 1 pots
 application mgcpapp
 destination-pattern 1
 port 1:1
 !
 !
gatekeeper
 shutdown
 !
 !
line con 0
 exec-timeout 0 0
 transport input none
line aux 0
line 2 3
line vty 0 4
 login
 length 0
 !
ntp clock-period 17248569
ntp server 172.29.1.129
end

```

## Example 4: SGCP 1.5 CAS PBX using Voice over ATM AAL2

The following figure and configuration illustrate the network connections for a Cisco MC3810 series platform with CAS running the MGCP application in SGCP 1.5 mode. ATM AAL2 carries voice traffic.

- T1/0 is configured to run ATM with three permanent virtual circuits (PVCs):
  - 1 PVC with encapsulation AAL5 carries SGCP messages (signaling VC)
  - 1 PVC with encapsulation AAL5 carries data traffic (data VC)
  - 1 PVC with encapsulation AAL2 carries voice traffic (bearer VC)

This bearer VC has a **vcci** of 2 assigned to it. The service manager uses this **vcci** value and a selected channel identifier (CID) value for a voice call on this router.

For AAL2, allocate 200 ATM cells/sec (84.8K bits/sec) for each G711u no vad call, 100 ATM cells/sec (42.4K bits/sec) for each G726-32 no vad or G729a no vad call.

- In this configuration, T1/1 is configured as three DS-0 groups:
  - 1 FXS ground start group
  - 1 E&M immediate start group
  - 1 E&M wink start group

For these voice ports, the dial type is set to **mf** to support mf dialing.

- **mgcp sgcp restart notify** is configured to enable SGCP RSIP messages notification.
- **mgcp modem passthrough mode** is configured to allow **nse** processing of fax or modem calls.

**Figure 5** SGCP 1.5 CAS PBX using Voice over ATM AAL2 Configuration**Router A Configuration**

```

version 12.1
no service pad
service timestamps debug uptime
service timestamps log uptime
no service password-encryption
!
hostname A
!
network-clock base-rate 56K
ip subnet-zero
!
mgcp
mgcp call-agent 10.0.0.1 service-type sgcp version 1.5
mgcp sgcp restart notify
mgcp tse payload 100
no mgcp timer receive-rtcp
mgcp timer net-cont-test 3000
isdn voice-call-failure 0
!
cns event-service server
voice-card 0
!
controller T1 0
  mode atm
  framing esf
  clock source line
  linecode b8zs
!
controller T1 1
  mode cas
  framing esf
  clock source line
  linecode b8zs
  ds0-group 1 timeslots 1-8 type e&m-immediate-start
  ds0-group 2 timeslots 9-16 type e&m-wink-start
  ds0-group 3 timeslots 17-24 type fxs-ground-start

```

```
!  
!  
interface Ethernet0  
  ip address 172.16.24.103 255.255.0.0  
!  
interface Serial0  
  no ip address  
  no ip route-cache  
  no ip mroute-cache  
  shutdown  
!  
interface Serial1  
  no ip address  
  no ip route-cache  
  no ip mroute-cache  
  shutdown  
  no cdp enable  
!  
interface ATM0  
  no ip address  
  ip mroute-cache  
  no atm ilmi-keepalive  
!  
interface ATM0.1 point-to-point  
  description signaling vc  
  ip address 10.0.0.2 255.0.0.0  
  pvc 1/1  
    vbr-rt 1536 64  
    encapsulation aal5snap  
!  
interface ATM0.2 point-to-point  
  description bearer vc  
  pvc 2/200  
    vbr-rt 1536 1400 100  
    encapsulation aal2  
    vcci 2  
!  
interface ATM0.3 point-to-point  
  description data vc  
  ip address 10.0.0.5 255.0.0.0  
  pvc 1/100  
    encapsulation aal5snap  
!  
interface FR-ATM20  
  no ip address  
  no ip route-cache  
  shutdown  
!  
ip classless  
no ip http server  
!  
!  
voice-port 1:1  
!  
voice-port 1:2  
  dial-type mf  
!  
voice-port 1:3  
!  
!  
dial-peer voice 1 pots  
  application MGCPAPP  
  port 1:1  
!
```

```

dial-peer voice 2 pots
  application MGCPAPP
  port 1:2
!
dial-peer voice 3 pots
  application MGCPAPP
  port 1:3
!
!
line con 0
  exec-timeout 0 0
  privilege level 15
  transport input none
line aux 0
line 2 3
line vty 0 4
  login
!
end

```

### Router B Configuration

```

version 12.1
no service pad
service timestamps debug uptime
service timestamps log uptime
no service password-encryption
!
hostname B
!
network-clock base-rate 56K
ip subnet-zero
!
mgcp
mgcp call-agent 10.0.0.1 service-type sgcp version 1.5
mgcp sgcp restart notify
mgcp tse payload 100
no mgcp timer receive-rtcp
mgcp timer net-cont-test 3000
isdn voice-call-failure 0
!
!
cns event-service server
voice-card 0
!
controller T1 0
  mode atm
  framing esf
  clock source line
  linecode b8zs
!
controller T1 1
  mode cas
  framing esf
  clock source line
  linecode b8zs
  ds0-group 1 timeslots 1-8 type e&m-immediate-start
  ds0-group 2 timeslots 9-16 type e&m-wink-start
  ds0-group3 timeslots 17-24 type fxs-ground-start
!
!
interface Ethernet0
  ip address 172.17.24.103 255.255.0.0

```

```
!  
interface Serial0  
  no ip address  
  no ip route-cache  
  no ip mroute-cache  
  shutdown  
!  
interface Serial1  
  no ip address  
  no ip route-cache  
  no ip mroute-cache  
  shutdown  
  no cdp enable  
!  
interface ATM0  
  no ip address  
  ip mroute-cache  
  no atm ilmi-keepalive  
!  
interface ATM0.1 point-to-point  
  description signaling vc  
  ip address 10.0.0.3 255.0.0.0  
  pvc 1/1  
    vbr-rt 1536 64  
    encapsulation aal5snap  
!  
interface ATM0.2 point-to-point  
  description bearer vc  
  pvc 2/200  
    vbr-rt 1536 1400 100  
    encapsulation aal2  
    vcci 2  
!  
interface ATM0.3 point-to-point  
  description data vc  
  ip address 10.0.0.8 255.0.0.0  
  pvc 1/100  
    encapsulation aal5snap  
!  
interface FR-ATM20  
  no ip address  
  no ip route-cache  
  shutdown  
!  
!  
ip classless  
no ip http server  
!  
!  
voice-port 1:1  
!  
voice-port 1:2  
  dial-type mf  
!  
voice-port 1:3  
!  
dial-peer voice 1 pots  
  application MGCPAPP  
  port 1:1  
!  
dial-peer voice 2 pots  
  application MGCPAPP  
  port 1:2  
!  
!
```

```

dial-peer voice 3 pots
  application MGCPAPP
  port 1:3
!
!
line con 0
  exec-timeout 0 0
  privilege level 15
  transport input none
line aux 0
line 2 3
line vty 0 4
  login
!
end

```

## Example 5: SGCP 1.5 CAS PBX using Voice over IP over ATM AAL5

The following figure and configuration illustrate the network connections for a Cisco MC3810 series platform with CAS running the MGCP application in SGCP 1.5 mode. Voice over IP over ATM AAL5 carries voice traffic.

This configuration is very similar to the AAL2 example in the previous section except that an AAL5 PVC is the bearer PVC for voice traffic.

This configuration has a loopback interface with an IP address assigned to it. During voice calls, the gateway gives this IP address to the service manager as the address for the other gateway of the voice connection to use as the destination IP address.

In the example below, Router A's loopback address is 192.168.1.0 and Router B's address is 192.168.5.0. If Router A originated a call to Router B, A would give 192.168.1.0 to the Service Manager and B would give 192.168.5.0. The IP route configuration commands of both routers direct the IP traffic into the voice bearer PVC since the loopback addresses are on different IP subnets.

For Voice over IP, allocate 300 ATM cells/sec (127.2K bits/sec) for each G711u no vad call, and 200 ATM cells/sec (84.8K bits/sec) for each G726-32 no vad or G729a no vad call.



### Note

---

For G711u no vad calls, a T1 running ATM does not have enough bandwidth to carry 24 voice calls.

---

**Figure 6** SGCP 1.5 CAS PBX using Voice over IP over ATM AAL5 Configuration**Router A Configuration**

```
version 12.1
no service pad
service timestamps debug uptime
service timestamps log uptime
no service password-encryption
!
hostname A
!
network-clock base-rate 56K
ip subnet-zero
!
mgcp
mgcp call-agent 10.0.0.1 service-type sgcp version 1.5
mgcp modem passthrough nse
mgcp sgcp restart notify
mgcp tse payload 100
no mgcp timer receive-rtcp
mgcp timer net-cont-test 3000
isdn voice-call-failure 0
!
!
cns event-service server
voice-card 0
!
controller T1 0
mode atm
framing esf
linecode b8zs
!
controller T1 1
mode cas
framing esf
clock source line
linecode b8zs
ds0-group 1 timeslots 1-8 type e&m-immediate-start
ds0-group 2 timeslots 9-16 type e&m-wink-start
```

```

    ds0-group 3 timeslots 17-24 type fxs-ground-start
    framing esf
    linecode b8zs
!
interface Loopback0
    ip address 192.168.1.0 255.255.255.0
!
interface Ethernet0
    ip address 172.16.24.103 255.255.0.0
!
interface Serial0
    no ip address
    no ip route-cache
    no ip mroute-cache
    shutdown
!
interface Serial1
    no ip address
    no ip route-cache
    no ip mroute-cache
    shutdown
    no cdp enable
!
interface ATM0
    no ip address
    ip mroute-cache
    no atm ilmi-keepalive
!
interface ATM0.1 point-to-point
    description signaling vc
    ip address 10.0.0.2 255.0.0.0
    pvc 1/1
        vbr-rt 1536 64
        encapsulation aal5snap
!
interface ATM0.2 point-to-point
    description bearer vc
    ip address 10.0.0.5 255.0.0.0
    pvc 1/2
        vbr-rt 1536 1400 100
        encapsulation aal5mux ip
!
interface ATM0.3 point-to-point
    description data vc
    ip address 10.0.0.8 255.0.0.0
    pvc 1/100
        encapsulation aal5snap
!
interface FR-ATM20
    no ip address
    no ip route-cache
    shutdown
!
ip classless
ip route 10.0.0.15 255.0.0.0 ATM0.2
no ip http server
!
!
voice-port 1:1
!
voice-port 1:2
    dial-type mf
!
voice-port 1:3

```

```

!
dial-peer voice 1 pots
  application MGCPAPP
  port 1:1
!
dial-peer voice 2 pots
  application MGCPAPP
  port 1:2
!
dial-peer voice 3 pots
  application MGCPAPP
  port 1:3
!
!
line con 0
  exec-timeout 0 0
  privilege level 15
  transport input none
line aux 0
line 2 3
line vty 0 4
  login
!
end

```

### Router B Configuration

```

version 12.1
no service pad
service timestamps debug uptime
service timestamps log uptime
no service password-encryption
!
hostname B
!
network-clock base-rate 56K
ip subnet-zero
!
!
mgcp
mgcp call-agent 10.0.0.1 service-type sgcp version 1.5
mgcp modem passthrough nse
mgcp sgcp restart notify
mgcp tse payload 100
no mgcp timer receive-rtcp
mgcp timer net-cont-test 3000
isdn voice-call-failure 0
!
cns event-service server
voice-card 0
!
controller T1 0
  mode atm
  framing esf
  linecode b8zs
!
controller T1 1
  mode cas
  ds0-group 1 timeslots 1-8 type e&m-immediate-start
  ds0-group 2 timeslots 9-16 type e&m-wink-start
  ds0-group 3 timeslots 17-24 type fxs-ground-start
  framing esf
  linecode b8zs
!

```

```

interface Loopback 0
  ip address 192.168.5.0 255.255.255.0
!
interface Ethernet0
  ip address 172.17.24.103 255.255.0.0
!
interface Serial0
  no ip address
  no ip route-cache
  no ip mroute-cache
  shutdown
!
interface Serial1
  no ip address
  no ip route-cache
  no ip mroute-cache
  shutdown
  no cdp enable
!
interface ATM0
  no ip address
  ip mroute-cache
  no atm ilmi-keepalive
!
interface ATM0.1 point-to-point
  description signaling vc
  ip address 10.0.0.3 255.0.0.0
  pvc 1/1
    vbr-rt 1536 64
    encapsulation aal5snap
!
interface ATM0.2 point-to-point
  description bearer vc
  ip address 10.0.0.6 255.0.0.0
  pvc 1/2
    vbr-rt 1536 1400 100
    encapsulation aal5mux ip
!
interface ATM0.3 point-to-point
  description data vc
  ip address 10.0.0.9 255.0.0.0
  pvc 1/100
    encapsulation aal5snap
!
interface FR-ATM20
  no ip address
  no ip route-cache
  shutdown
!
ip classless
ip route 10.0.0.16 255.0.0.0 ATM0.2
no ip http server
!
!
voice-port 1:1
!
voice-port 1:2
  dial-type mf
!
voice-port 1:3
!
dial-peer voice 1 pots
  application MGCPAPP
  port 1:1

```

```
!
dial-peer voice 2 pots
  application MGCPAPP
  port 1:2
!
dial-peer voice 3 pots
  application MGCPAPP
  port 1:3
!
!
line con 0
  exec-timeout 0 0
  privilege level 15
  transport input none
line aux 0
line 2 3
line vty 0 4
  login
!
end
```

## Example 6: SGCP 1.5 Analog E&M PBX using Voice over ATM AAL2

The following figure and configuration illustrate the network connections for a Cisco MC3810 series platform with Analog E&M running the MGCP application in SGCP 1.5 mode. ATM AAL2 carries voice traffic.

This configuration is similar to the SGCP 1.5 CAS PBX using Voice over ATM AAL2 configuration, with these exceptions:

- No DS-0 groups are configured for T1/1 because the slot is used by analog voice.
- The E&M port must be configured to match the type of analog PBX to which the port is connected.
- E&M protocol is set to either E&M immediate or wink start. For wink start, set the dial-type to **mf**.
- Operation must be set to 2-w (for 2-wire) or 4-w (for 4-wire).
- Type is set to I, II, IV, or V.

In this example, the bearer PVC has enough bandwidth for two G711u no vad calls because the router has only two voice ports.

**Figure 7** SGCP 1.5 Analog E&M PBX using Voice over ATM AAL2 Configuration**Router A Configuration**

```
version 12.1
no service pad
service timestamps debug uptime
service timestamps log uptime
no service password-encryption
!
hostname A
!
network-clock base-rate 56K
ip subnet-zero
!
mgcp
mgcp call-agent 10.0.0.1 service-type sgcp version 1.5
mgcp tse payload 100
no mgcp timer receive-rtcp
mgcp timer net-cont-test 3000
mgcp sgcp restart notify
isdn voice-call-failure 0
!
!
cns event-service server
voice-card 0
!
controller T1 0
    mode atm
    framing esf
    linecode b8zs
!
interface Ethernet0
    ip address 172.16.24.101 255.255.0.0
!
interface Serial0
    no ip address
    no ip route-cache
    no ip mroute-cache
    shutdown
```

```
!  
interface Serial1  
  no ip address  
  no ip route-cache  
  no ip mroute-cache  
  shutdown  
  no cdp enable  
!  
interface ATM0  
  no ip address  
  ip mroute-cache  
  no atm ilmi-keepalive  
!  
interface ATM0.1 point-to-point  
  description signaling vc  
  ip address 10.0.0.2 255.0.0.0  
  pvc 1/1  
    vbr-rt 1536 64  
    encapsulation aal5snap  
!  
interface ATM0.2 point-to-point  
  description bearer vc  
  pvc 1/2  
    vbr-rt 1536 170 8  
    encapsulation aal2  
    vcci 2  
!  
interface ATM0.3 point-to-point  
  description data vc  
  ip address 10.0.0.5 255.0.0.0  
  pvc 1/100  
    encapsulation aal5snap  
!  
interface FR-ATM20  
  no ip address  
  no ip route-cache  
  shutdown  
!  
ip classless  
no ip http server  
!  
!  
voice-port 1/3  
  operation 4-wire  
  type 2  
  signal immediate  
!  
voice-port 1/4  
  operation 4-wire  
  type 2  
  dial-type mf  
!  
!  
dial-peer voice 3 pots  
  application MGCPAPP  
  port 1/3  
!  
dial-peer voice 4 pots  
  application MGCPAPP  
  port 1/4  
!  
line con 0  
  exec-timeout 0 0  
  privilege level 15
```

```

transport input none
line aux 0
line 2 3
line vty 0 4
  login
!
end

```

### Router B Configuration

```

version 12.1
no service pad
service timestamps debug uptime
service timestamps log uptime
no service password-encryption
!
hostname B
!
network-clock base-rate 56K
ip subnet-zero
!
mgcp
mgcp call-agent 10.0.0.1 service-type sgcp version 1.5
mgcp tse payload 100
no mgcp timer receive-rtcp
mgcp timer net-cont-test 3000
mgcp sgcp restart notify
isdn voice-call-failure 0
!
!
cns event-service server
voice-card 0
!
controller T1 0
  mode atm
  framing esf
  linecode b8zs
!
!
interface Ethernet0
  ip address 172.17.24.101 255.255.0.0
!
interface Serial0
  no ip address
  no ip route-cache
  no ip mroute-cache
  shutdown
!
interface Serial1
  no ip address
  no ip route-cache
  no ip mroute-cache
  shutdown
  no cdp enable
!
interface ATM0
  no ip address
  ip mroute-cache
  no atm ilmi-keepalive
!
interface ATM0.1 point-to-point
  description signaling vc
  ip address 10.0.0.3 255.0.0.0

```

```
pvc 1/1
  vbr-rt 1536 64
  encapsulation aal5snap
!
interface ATM0.2 point-to-point
  description bearer vc
  pvc 1/2
    vbr-rt 1536 170 8
    encapsulation aal2
    vcci 2
!
interface ATM0.3 point-to-point
  description data vc
  ip address 10.0.0.6 255.0.0.0
  pvc 1/100
    encapsulation aal5snap
!
interface FR-ATM20
  no ip address
  no ip route-cache
  shutdown
!
ip classless
no ip http server
!
!
voice-port 1/3
  operation 2-wire
  type 1
  signal immediate
!
voice-port 1/4
  operation 4-wire
  type 2
  dial-type mf
!
!
dial-peer voice 3 pots
  application MGCPAPP
  port 1/3
!
dial-peer voice 4 pots
  application MGCPAPP
  port 1/4
!
!
line con 0
  exec-timeout 0 0
  privilege level 15
  transport input none
line aux 0
line 2 3
line vty 0 4
  login
!
end
```

## Example 7: SGCP 1.5 Analog E&M PBX using Voice over IP over ATM AAL5

The following figure and configuration illustrate the network connections for a Cisco MC3810 series platform RGW with analog FXS loopstart ports running the MGCP application in SGCP 1.5 mode. Voice over IP over ATM AAL5 carries voice traffic.

This configuration is similar to the SGCP 1.5 CAS PBX using Voice over IP over ATM AAL5 configuration, with these exceptions:

- No DS-0 groups are configured for T1/1 because the slot is used by analog voice.
- The E&M port must be configured to match the type of analog PBX to which the port is connected.
- E&M protocol is set to either E&M immediate or wink start. For wink start, set the dial-type to **mf**.
- Operation must be set to 2-w (for 2-wire) or 4-w (for 4-wire).
- Type is set to I, II, IV, or V.

In this example, the bearer PVC has enough bandwidth for two G711u no vad calls because the router has only two voice ports.

**Figure 8** SGCP 1.5 Analog E&M PBX using Voice over IP over ATM AAL5 Configuration

### Router A Configuration

```

version 12.1
no service pad
service timestamps debug uptime
service timestamps log uptime
no service password-encryption
!
hostname A
!
!
network-clock base-rate 56K
ip subnet-zero
!
!
```

```
mgcp
mgcp call-agent 10.0.0.1 service-type sgcp version 1.5
mgcp tse payload 100
no mgcp timer receive-rtcp
mgcp timer net-cont-test 3000
mgcp sgcp restart notify
isdn voice-call-failure 0
!
!
cns event-service server
voice-card 0
!
controller T1 0
  mode atm
  framing esf
  linecode b8zs
!
interface Loopback0
  ip address 10.0.0.2 255.0.0.
!
interface Ethernet0
  ip address 172.16.24.101 255.255.0.0
!
interface Serial0
  no ip address
  no ip route-cache
  no ip mroute-cache
  shutdown
!
interface Serial1
  no ip address
  no ip route-cache
  no ip mroute-cache
  shutdown
!
interface ATM0
  no ip address
  ip mroute-cache
  no atm ilmi-keepalive
!
interface ATM0.1 point-to-point
  description signaling vc
  ip address 10.0.0.5 255.0.0.0
  pvc 1/1
    vbr-rt 1536 64
    encapsulation aal5snap
!
interface ATM0.2 point-to-point
  description bearer vc
  ip address 10.0.0.6 255.0.0.0
  pvc 1/2
    vbr-rt 1536 260 8
    encapsulation aal5mux ip
!
interface ATM0.3 point-to-point
  description data vc
  ip address 10.0.0.8 255.0.0.0
  pvc 1/100
    encapsulation aal5snap
!
interface FR-ATM20
  no ip address
  no ip route-cache
  shutdown
```

```

!
ip classless
ip route 10.0.0.0 255.0.0.0 ATM0.2
no ip http server
!
!
voice-port 1/3
    operation 4-wire
    type 2
    signal immediate
!
voice-port 1/4
    operation 4-wire
    type 2
    dial-type mf
!
!
dial-peer voice 3 pots
    application MGCPAPP
    port 1/3
!
dial-peer voice 4 pots
    application MGCPAPP
    port 1/4
!
line con 0
    exec-timeout 0 0
    privilege level 15
    transport input none
line aux 0
line 2 3
line vty 0 4
    login
!
end

```

### Router B Configuration

```

version 12.1
no service pad
service timestamps debug uptime
service timestamps log uptime
no service password-encryption
!
hostname B
!
network-clock base-rate 56K
ip subnet-zero
!
!
!
mgcp
mgcp call-agent 10.0.0.1 service-type sgcp version 1.5
mgcp tse payload 100
no mgcp timer receive-rtcp
mgcp timer net-cont-test 3000
mgcp sgcp restart notify
isdn voice-call-failure 0
!
!
cns event-service server
voice-card 0
!
!

```

```
controller T1 0
  mode atm
  framing esf
  linecode b8zs
!
!
interface Loopback0
  ip address 10.0.0.3 255.0.0.0

interface Ethernet0
  ip address 172.17.24.101 255.255.0.0
!
interface Serial0
  no ip address
  no ip route-cache
  no ip mroute-cache
  shutdown
!
interface Serial1
  no ip address
  no ip route-cache
  no ip mroute-cache
  shutdown
!
interface ATM0
  no ip address
  ip mroute-cache
  no atm ilmi-keepalive
!
interface ATM0.1 point-to-point
  description signaling vc
  ip address 10.0.0.7 255.0.0.0
  pvc 1/1
    vbr-rt 1536 64
    encapsulation aal5snap
!
interface ATM0.2 point-to-point
  description bearer vc
  ip address 10.0.0.9 255.0.0.0
  pvc 1/2
    vbr-rt 1536 170 8
    encapsulation aal5mux ip
!
interface ATM0.3 point-to-point
  description data vc
  ip address 10.0.0.10 255.0.0.0
  pvc 1/100
    encapsulation aal5snap
!
interface FR-ATM20
  no ip address
  no ip route-cache
  shutdown
!
ip classless
ip route 10.0.0.20 255.0.0.0 ATM0.2
no ip http server
!
!
voice-port 1/3
  operation 4-wire
  type 2
  signal immediate
!
```

```

voice-port 1/4
  operation 4-wire
  type 2
  dial-type mf
!
!
dial-peer voice 3 pots
  application MGCPAPP
  port 1/3
!
dial-peer voice 4 pots
  application MGCPAPP
  port 1/4
!
!
line con 0
  exec-timeout 0 0
  privilege level 15
  transport input none
line aux 0
line 2 3
line vty 0 4
  login
!
end

```

## Example 8: SGCP 1.5 RGW using Voice over ATM AAL2

The following figure and configuration illustrate the network connections for a Cisco MC3810 series platform RGW with analog FXS port running the MGCP application in SGCP 1.5 mode. ATM AAL2 carries voice traffic.

This configuration is similar to the SGCP 1.5 CAS PBX using Voice over ATM AAL2 configuration, with these exceptions:

- No DS-0 groups are configured for T1/1 because the slot is used by analog voice.
- For RGW, the FXS ports' signaling are set to loop start, which is the default.

In this example, the bearer PVC has enough bandwidth for two G711u no vad calls because the router has only two voice ports.

**Figure 9** SGCP 1.5 RGW using Voice over ATM AAL2 Configuration**Router A Configuration**

```
version 12.1
no service pad
service timestamps debug uptime
service timestamps log uptime
no service password-encryption
!
hostname A
!
network-clock base-rate 56K
ip subnet-zero
!
mgcp
mgcp call-agent 10.0.0.1 service-type sgcp version 1.5
mgcp sgcp restart notify
mgcp tse payload 100
no mgcp timer receive-rtcp
mgcp timer net-cont-test 3000
isdn voice-call-failure 0
!
cns event-service server
voice-card 0
!
controller T1 0
mode atm
framing esf
linecode b8zs
!
interface Ethernet0
ip address 172.16.24.101 255.255.0.0
!
interface Serial0
no ip address
no ip route-cache
no ip mroute-cache
shutdown
!
```

```

interface Serial1
  no ip address
  no ip route-cache
  no ip mroute-cache
  shutdown
  no cdp enable
!
interface ATM0
  no ip address
  ip mroute-cache
  no atm ilmi-keepalive
!
interface ATM0.1 point-to-point
  description signaling vc
  ip address 10.0.0.2 255.0.0.0
  pvc 1/1
    vbr-rt 1536 64
    encapsulation aal5snap
!
interface ATM0.2 point-to-point
  description bearer vc
  pvc 1/2
    vbr-rt 1536 170 8
    encapsulation aal2
    vcci 2
!
interface ATM0.3 point-to-point
  description data vc
  ip address 10.0.0.5 255.0.0.0
  pvc 1/100
    encapsulation aal5snap
!
interface FR-ATM20
  no ip address
  no ip route-cache
  shutdown
!
ip classless
no ip http server
!
!
voice-port 1/1
!
voice-port 1/2
!
dial-peer voice 1 pots
  application MGCPAPP
  port 1/1
!
dial-peer voice 2 pots
  application MGCPAPP
  port 1/2
!
!
line con 0
  exec-timeout 0 0
  privilege level 15
  transport input none
line aux 0
line 2 3
line vty 0 4
  login
!
end

```

**Router B Configuration**

```
version 12.1
no service pad
service timestamps debug uptime
service timestamps log uptime
no service password-encryption
!
hostname B
!
network-clock base-rate 56K
ip subnet-zero
!
mgcp
mgcp call-agent 10.0.0.1 service-type sgcp version 1.5
mgcp sgcp restart notify
mgcp tse payload 100
no mgcp timer receive-rtcp
mgcp timer net-cont-test 3000
isdn voice-call-failure 0
!
cns event-service server
voice-card 0
!
controller T1 0
    mode atm
    framing esf
    linecode b8zs
!
!
interface Ethernet0
    ip address 172.17.24.101 255.255.0.0
!
interface Serial0
    no ip address
    no ip route-cache
    no ip mroute-cache
    shutdown
!
interface Serial1
    no ip address
    no ip route-cache
    no ip mroute-cache
    shutdown
    no cdp enable
!
interface ATM0
    no ip address
    ip mroute-cache
    no atm ilmi-keepalive
!
interface ATM0.1 point-to-point
    description signaling vc
    ip address 10.0.0.3 255.0.0.0
    pvc 1/1
        vbr-rt 1536 64
        encapsulation aal5snap
!
interface ATM0.2 point-to-point
    description bearer vc
    pvc 1/2
        vbr-rt 1536 170 8
        encapsulation aal2
        vcci 2
```

```

!
interface ATM0.3 point-to-point
  description data vc
  ip address 10.0.0.6 255.0.0.0
  pvc 1/100
    encapsulation aal5snap
!
interface FR-ATM20
  no ip address
  no ip route-cache
  shutdown
!
ip classless
no ip http server
!
!
voice-port 1/1
!
voice-port 1/2
!
dial-peer voice 1 pots
  application MGCPAPP
  port 1/1
!
dial-peer voice 2 pots
  application MGCPAPP
  port 1/2
!
!
line con 0
  exec-timeout 0 0
  privilege level 15
  transport input none
line aux 0
line 2 3
line vty 0 4
  login
!
end

```

## Example 9: SGCP 1.5 RGW using Voice over IP over ATM AAL5

The following figure and configuration illustrate the network connections for a Cisco MC3810 series platform RGW with analog FXS port running the MGCP application in SGCP 1.5 mode. Voice over IP over ATM AAL5 carries voice traffic.

This configuration is similar to the SGCP 1.5 CAS PBX Voice Over ATM AAL5 configuration, with these exceptions:

- No DS-0 groups are configured for T1/1 because the slot is used by analog voice.
- For RGW, the FXS ports' signaling are set to loop start, which is the default.

In this example, the bearer PVC has enough bandwidth for two G711u no vad calls because the router has only two voice ports.



```

!
interface Serial1
  no ip address
  no ip route-cache
  no ip mroute-cache
  shutdown
!
interface ATM0
  no ip address
  ip mroute-cache
  no atm ilmi-keepalive
!
interface ATM0.1 point-to-point
  description signaling vc
  ip address 10.0.0.2 255.0.0.0
  pvc 1/1
    vbr-rt 1536 64
    encapsulation aal5snap
!
interface ATM0.2 point-to-point
  description bearer vc
  ip address 10.0.0.5 255.0.0.0
  pvc 1/2
    vbr-rt 1536 260 8
    encapsulation aal5mux ip
!
interface ATM0.3 point-to-point
  description data vc
  ip address 10.0.0.8 255.0.0.0
  pvc 1/100
    encapsulation aal5snap
!
interface FR-ATM20
  no ip address
  no ip route-cache
  shutdown
!
ip classless
ip route 10.0.0.10 255.0.0.0 ATM0.2
no ip http server
!
voice-port 1/1
!
voice-port 1/2
!
dial-peer voice 1 pots
  application MGCPAPP
  port 1/1
!
dial-peer voice 2 pots
  application MGCPAPP
  port 1/2
!
!
line con 0
  exec-timeout 0 0
  privilege level 15
  transport input none
line aux 0
line 2 3
line vty 0 4
  login
!
end

```

**Router B Configuration**

```

version 12.1
no service pad
service timestamps debug uptime
service timestamps log uptime
no service password-encryption
!
hostname B
!
network-clock base-rate 56K
ip subnet-zero
!
mgcp
mgcp call-agent 10.0.0.1 service-type sgcp version 1.5
mgcp sgcp restart notify
mgcp tse payload 100
no mgcp timer receive-rtcp
mgcp timer net-cont-test 3000
isdn voice-call-failure 0
!
!
cns event-service server
voice-card 0
!
controller T1 0
    mode atm
    framing esf
    linecode b8zs
!
!
interface Ethernet0
    ip address 172.17.24.101 255.255.0.0
!
interface Serial0
    no ip address
    no ip route-cache
    no ip mroute-cache
    shutdown
!
interface Serial1
    no ip address
    no ip route-cache
    no ip mroute-cache
    shutdown
!
interface ATM0
    no ip address
    ip mroute-cache
    no atm ilmi-keepalive
!
interface ATM0.1 point-to-point
    description signaling vc
    ip address 10.0.0.3 255.0.0.0
    pvc 1/1
        vbr-rt 1536 64
        encapsulation aal5snap
!
interface ATM0.2 point-to-point
    description bearer vc
    ip address 10.0.0.6 255.0.0.0
    pvc 1/2
        vbr-rt 1536 260 8
        encapsulation aal5mux ip

```

```
!  
interface ATM0.3 point-to-point  
  description data vc  
  ip address 10.0.0.7 255.0.0.0  
  pvc 1/100  
    encapsulation aal5snap  
!  
interface FR-ATM20  
  no ip address  
  no ip route-cache  
  shutdown  
!  
ip classless  
ip route 10.0.0.12 255.0.0.0 ATM0.2  
no ip http server  
!  
!  
voice-port 1/1  
!  
voice-port 1/2  
!  
dial-peer voice 1 pots  
  application MGCPAPP  
  port 1/1  
!  
dial-peer voice 2 pots  
  application MGCPAPP  
  port 1/2  
!  
!  
line con 0  
  exec-timeout 0 0  
  privilege level 15  
  transport input none  
line aux 0  
line 2 3  
line vty 0 4  
  login  
!  
end
```

# Command Reference

This section documents new or modified commands. All other commands used with this feature are documented in the Cisco IOS Release 12.1 command reference publications.

## New Commands

- [mgcp explicit hookstate](#)
- [mgcp modem passthrough voip redundancy](#)
- [mgcp quarantine mode](#)
- [mgcp quarantine persistent-events disable](#)
- [vcci](#)

## Modified Commands

- [application](#)
- [debug mgcp](#)
- [dial-type](#)
- [ds0-group](#)
- [encapsulation](#)
- [mgcp](#)
- [mgcp call-agent](#)
- [mgcp codec](#)
- [mgcp default-package](#)
- [mgcp dtmf-relay](#)
- [mgcp ip-tos](#)
- [mgcp modem passthrough codec](#)
- [mgcp modem passthrough mode](#)
- [mgcp package-capability](#)
- [mgcp quality-threshold](#)
- [mgcp request retries](#)
- [mgcp request timeout](#)
- [mgcp restart-delay](#)
- [mgcp sgcp restart notify](#)
- [mgcp timer](#)
- [mgcp tse payload](#)
- [mgcp vad](#)
- [mode \(Voice over ATM\)](#)
- [pvc](#)
- [show mgcp](#)
- [vbr-rt](#)

# application

To enable a specific application on a dial-peer, use the **application** dial-peer command. To remove the application from the dial-peer, use the **no** form of this command.

**application** *name*

**no application** *name*

## Syntax Description

<i>name</i>	Indicates the name of the application enabled on the dial peer. Valid value is <b>MGCPAPP</b> (or <b>mgcpapp</b> ).
-------------	---

## Defaults

No default behavior or values.

## Command Modes

Dial-peer configuration

## Command History

Release	Modification
11.3(6)NA2	This command was introduced.
12.0(5)T	The SGCPAPP application was first supported on the Cisco AS5300 in a private release that was not generally available.
12.0(7)XK	Support for the SGCPAPP application was extended to the Cisco MC3810 series and the Cisco 3600 series routers (except for the Cisco 3620) in a private release that was not publicly available.
12.1(3)T	The MGCPAPP application was first supported on the Cisco AS5300 router.
12.1(5)XM	Support for the MGCPAPP application was extended to the Cisco MC3810 series and Cisco 3660 platforms. SGCPAPP was removed as a valid application name.

## Usage Guidelines

Enter the **MGCPAPP** value in upper- or lower-case characters. The SGCPAPP application is no longer a valid entry for *name*. MGCPAPP supports both MGCP and SGCP commands.

## Examples

The following example shows how to apply the MGCP application to a dial peer:

```
Router(config)# dial-peer voice 1 pots
Router(config-dial-peer)# application MGCPAPP
```

## Related Commands

Command	Description
<a href="#">mgcp</a>	Starts the MGCP daemon.

# debug mgcp

To enable debug traces for errors, events, packets, and parser, use the **debug mgcp** privileged EXEC command. To disable debugging output, use the **no** form of this command.

```
debug mgcp [all | errors | events | packets | parser]
```

```
no debug mgcp [all | errors | events | packets | parser]
```

Syntax Description	all	(Optional) Debugs errors, events, packets, and the parser for MGCP modules.
	<b>errors</b>	(Optional) Debugs errors for MGCP modules.
	<b>events</b>	(Optional) Debugs events for MGCP modules.
	<b>packets</b>	(Optional) Debugs packets for MGCP modules.
	<b>parser</b>	(Optional) Debugs the parser for MGCP modules.

**Defaults** Debugging for DRiP packets is not enabled.

**Command Modes** EXEC

Command History	Release	Modification
	12.1(1)T	This command was introduced for the Cisco AS5300.
	12.1(3)T	Additional information is displayed for the gateways.
	12.1(5)XM	The output was modified to display parameters for the MGCP CAS PBX and AAL2 PVC features.

**Examples** Following are sample output for the **debug mgcp packets**, **debug mgcp events**, and **debug mgcp parser** commands. The **debug mgcp all** would show a compilation of all these commands.

The following example illustrates the output for the **debug mgcp events** command:

```
Router# debug mgcp events

Media Gateway Control Protocol events debugging is on
Router#
lwd: MGC stat - 171.69.184.65, total=44, succ=7, failed=21
lwd: MGCP msg 1
lwd: remove_old_under_specified_ack:
lwd: MGC stat - 171.69.184.65, total=44, succ=8, failed=21
lwd: updating lport with 2427setup_ipsocket: laddr=172.29.248.193, lport=2427,
faddr=171.69.184.65, fport=2427
lwd: enqueue_ack: ackqhead=0, ackqtail=0, ackp=1DC1D38, msg=21A037C
Router#
```

The following example illustrates the output for the **debug mgcp packets** command:

```
Router# debug mgcp packets

Media Gateway Control Protocol packets debugging is on
Router# Media Gateway Control Protocol packets debugging is on
Router#
1w1d: MGCP Packet received -
DLCX 408631346 * MGCP 0.1

1w1d: send_mgcp_msg, MGCP Packet sent --->

1w1d: 250 408631346
<---
```

The following example illustrates the output for the **debug mgcp parser** command:

```
Router# debug mgcp parser

Media Gateway Control Protocol parser debugging is on
Router#
1w1d: -- mgcp_parse_packet() - call mgcp_parse_header
- mgcp_parse_header()- Request Verb FOUND DLCX
- mgcp_parse_packet() - out mgcp_parse_header
- SUCCESS: mgcp_parse_packet()- MGCP Header parsing was OK
- mgcp_val_mandatory_parms()
- SUCCESS: mgcp_parse_packet()- END of Parsing

1w1d: -- mgcp_build_packet()-

1w1d: - mgcp_estimate_msg_buf_length() - 87 bytes needed for header
- mgcp_estimate_msg_buf_length() - 87 bytes needed after checking parameter lines
- mgcp_estimate_msg_buf_length() - 87 bytes needed after cheking SDP lines
- SUCCESS: MGCP message building OK
- SUCCESS: END of building
Router#
```

## Related Commands

Command	Description
<a href="#">mgcp</a>	Initiates the MGCP daemon.

# dial-type

To specify the type of out-dialing for voice port interfaces, use the **dial-type** voice-port configuration command. Use the **no** form of this command to disable the selected type of dialing.

**dial-type** { **dtmf** | **pulse** | **mf** }

**no dial-type**

## Syntax Description

<b>dtmf</b>	DTMF (touch-tone) dialing.
<b>pulse</b>	Pulse (rotary) dialing.
<b>mf</b>	Multifrequency tone dialing.

## Defaults

**dtmf**

## Command Modes

Voice-port configuration

## Command History

Release	Modification
11.3(1)T	This command was introduced.
11.3(1)MA3	The <b>pulse-dialer</b> option was added.
12.0(7)XK	The <b>mf</b> option was added.
12.1(5)XM	Support for this command was extended to the merged SGCP/MGCP software image.

## Usage Guidelines

Use the **dial-type** command to specify an out-dialing type for an FXO or E&M voice port interface; this command is not applicable to all voice ports because the ports do not generate out-dialing. Voice ports can always detect dtmf and pulse signals. This command does not affect voice port dialing detection.

The **dial-type** command affects out-dialing as configured for the dial peer.

The **dial-type** command is not supported on FXO voice port interfaces on the Cisco MC3810 series platform. If you are using the **dial-type** command with E&M wink-start, use the **mf** option.

SGCP 1.1+ does not support **pulse** dialing.

## Examples

The following example configures a voice port on the Cisco MC3810 series platform to support a rotary (pulse tone) dialer:

```
Router(config)# voice-port 1/1
Router(config-voice-port)# dial-type pulse
```

The following example configures a voice port on the Cisco MC3810 series platform to support a DTMF (touch-tone) dialer:

```
Router(config)# voice-port 1/1  
Router(config-voice-port)# dial-type dtmf
```

The following example configures a voice port on the Cisco MC3810 series platform to support a Multifrequency Tone dialer:

```
Router(config)# voice-port 1/1  
Router(config-voice-port)# dial-type mf
```

# ds0-group

To configure channelized T1 timeslots on a Cisco AS5300 trunking gateway to answer and send an analog call, use the **ds0-group** controller configuration command. To disable a DS-0 configuration for one or more timeslots, use the **no** form of this command.

```
ds0-group channel-number timeslots range type signaling-type tone type addr info service
service-type
```

```
no ds0-group channel-number timeslots range
```

Syntax Description	
<i>channel-number</i>	Specifies the DS-0 group number, which can be between 0 and 23 for T1 interfaces, and from 0 to 30 for E1 interfaces.
<b>timeslots</b> <i>range</i>	Specifies the DS-0 timeslot range of values from 1 to 24 for T1 interfaces, and from 1 to 31 for E1 interfaces. The default value configures 24 timeslots with the channel associated signal called E&M (Ear and Mouth), which is the default signal type.
<b>type</b> <i>signaling-type</i>	(Optional) Specifies the signaling type to be applied to the selected group. For mgcp functionality, choose <b>none</b> . For sgcp functionality, choose <b>none</b> or <b>fgd-os</b> .
<b>tone type</b>	(Optional) Specifies the tone type as <b>dtmf</b> or <b>mf</b> . This option is not available with <i>signaling-type</i> <b>none</b> . For <b>fgd-os</b> signaling, choose <b>mf</b> .
<b>addr info</b>	(Optional) Specifies that calling/called party numbers may be applied. This option is not available with signaling type <b>none</b> . For <b>fgd-os</b> signaling, use <b>dnis-ani</b> .
<b>service</b> <i>service-type</i>	(Optional) Specifies the type of service. If the <i>signaling-type</i> is <b>none</b> , then valid <i>service-type</i> option is <b>mgcp</b> . If the <i>signaling-type</i> is <b>fgd-os</b> , then the valid <i>service-type</i> option is <b>voice</b> .

**Defaults** No default behavior or values.

**Command Modes** Controller configuration

Command History	Release	Modification
	11.2	This command was introduced as the <b>cas-group</b> command.
	12.0(5)T	The command was renamed.
	12.1(1)T	The MGCP service type was added.
	12.1(3)T	The fgdos signaling type and voice service type were added.
	12.1(5)XM	SGCP was removed as a valid service type.

**Usage Guidelines**

This command is available only on the AS5300 trunking gateway.

The **fgdos** option for *signaling-type* supports the FGD-OS capability available in SGCP. This capability is not supported in MGCP.

Use **mgcp** for *service-type* if you want the full set of MGCP features and functionality. Note that FGD-OS features are not available in MGCP.

Use **voice** for *service-type* if you want SGCP functionality with the FGD-OS features.

The *service-type* value indicates the set of features to be used for the gateway once the **mgcp EXEC** command is entered to initiate MGCP functionality.

**Examples**

The following example illustrates setting the T1 channels for SS7 service on any TGW in mgcp mode:

```
Router(config)# ds0-group 0 timeslots 1-24 type none service mgcp
```

The following example illustrates setting the T1 channels for FGD-OS service on a Cisco AS5300 in SGCP mode:

```
Router(config)# ds0-group 0 timeslots 1-24 type fgd-os mf dnis-ani service voice
```

**Related Commands**

Command	Description
<b>cas-group</b>	Configures channelized T1 timeslots with robbed bit signaling.
<b>mgcp</b>	Starts the MGCP daemon.

# encapsulation

To configure the ATM adaptation layer (AAL) and encapsulation type for an ATM PVC, use the **encapsulation** command in the virtual circuit configuration mode. Use the **no** form of this command to remove an encapsulation from a PVC.

**encapsulation** *aal-encap*

**no encapsulation** *aal-encap*

## Syntax Description

*aal-encap* ATM adaptation layer (AAL) and encapsulation type. Valid values are **aal2**, **aal5snap**, or **aal5mux ip**.

## Defaults

The global default encapsulation is **aal5snap**.

## Command Modes

Virtual circuit (vc) configuration

## Command History

Release	Modification
11.3T	This command was first introduced.
12.0	This command superseded the <b>encapsulation atm</b> command for the Cisco MC3810 series platform, and the <b>aal5mux frame</b> and <b>aal5mux voice</b> suboptions appeared.
12.0(7)XK	Support for the <b>aal5mux voice</b> option was added to the Cisco 3600 series routers.
12.1(1)XA	Support for the <b>aal2</b> option was added to the Cisco MC3810 series concentrators.
12.1(5)XM	Support for the <b>aal2</b> option was added to the Cisco AS5300 access server and Cisco 3600 multiservice platforms.

## Usage Guidelines

Use **aal2** encapsulation to dedicate the specified PVC to AAL2 Voice over ATM.

If you specify virtual template parameters after the ATM PVC is configured, you should issue a **shutdown** command followed by a **no shutdown** command on the ATM subinterface to restart the interface, causing the newly configured parameters (such as an IP address) to take effect.

## Examples

The following example configures a PVC to support AAL2 encapsulation for Voice over ATM on a Cisco MC3810 series concentrator:

```
Router(config-interface-atm) # pvc 20/20
Router(config-interface-atm-vc) # encapsulation aal2
```

# mgcp

To start and allocate resources for the MGCP daemon, use the **mgcp** global configuration command. To terminate all calls, release all allocated resources, and kill the MGCP daemon, use the **no** form of this command.

**mgcp** [*port*]

**no mgcp**

<b>Syntax Description</b>	<i>port</i>	(Optional) Specifies a UDP port for the MGCP gateway. Valid values are 1025 through 65,535.
---------------------------	-------------	---

<b>Defaults</b>	UDP port 2427
-----------------	---------------

<b>Command Modes</b>	Global configuration
----------------------	----------------------

<b>Command History</b>	<b>Release</b>	<b>Modification</b>
	12.1(1)T	This command was introduced for the Cisco AS5300.
	12.1(3)T	Support for this command was extended to the Cisco 3660, Cisco uBR924, and Cisco 2600 series platforms.
	12.1(5)XM	Support for this command was extended to the Cisco MC3810 series platform.

**Usage Guidelines**

After you start the MGCP daemon with the **mgcp** command, you can suspend it (for example, for maintenance) by using the **mgcp block-newcalls** command. When you are ready to resume normal MGCP operations, use the **no mgcp block-newcalls** command. Use the **no mgcp** command only if you intend to stop all MGCP applications and protocols.

When the MGCP daemon is not active, all MGCP messages are ignored.

If you do not specify a port from the command line, MGCP will use UDP port 2427.

If you want to change the UDP port while MGCP is running, you must shut down mgcp using the **no mgcp** command, then restart MGCP with the new port number using the **mgcp port** command.

**Examples**

The following example shows how to enable the MGCP daemon on port 4204:

```
Router(config)# mgcp 4204
```

Related Commands	Command	Description
	<b>mgcp block-newcalls</b>	Gracefully terminates all MGCP activity.
	<b>mgcp request retries</b>	Specifies the number of times to retry sending the <b>mgcp</b> command.
	<b>debug mgcp</b>	Enables debugging on MGCP.
	<b>show mgcp</b>	Displays the MGCP parameter settings.

# mgcp call-agent

To configure the call agent's (media gateway controller) address, use the **mgcp call-agent** global configuration command. To unconfigure the call agent's address, use the **no** form of this command.

```
mgcp call-agent {ipaddr | hostname} [port] [service-type type] [version version-number]
```

```
no mgcp call-agent
```

## Syntax Description

<i>ipaddr</i>   <i>hostname</i>	Specifies the IP address or domain name of the call-agent.
<i>port</i>	(Optional) Specifies the port for the call-agent to use. Valid values are 1025 through 65535.
<b>service-type</b> <i>type</i>	(Optional) Specifies the type of gateway control service to be supported by the call agent. Valid values are <b>mgcp</b> or <b>sgcp</b> .
<b>version</b> <i>version-number</i>	(Optional) Specifies the version of <b>service-type</b> . For <b>mgcp</b> , the only valid value is 0.1. For <b>sgcp</b> , valid values are 1.1 or 1.5.

## Defaults

port: 2427

service-type: mgcp

## Command Modes

Global configuration

## Command History

Release	Modification
12.1(1)T	This command was introduced for the Cisco AS5300.
12.1(3)T	The <b>service-type</b> parameter was added to the command.
12.1(5)XM	The command was expanded to the Cisco MC3810 series and Cisco 3600 multiservice platforms and the <b>version</b> parameter was added.

## Usage Guidelines

Use this command on any platform and media gateway.

If you do not specify a UDP port from the command line, MGCP will use 2427 as the default call agent UDP port.

The service-type **mgcp** supports the RSIP error messages sent by the gateway if **mgcp sgcp restart notify** is enabled. The service-type **sgcp** ignores the RSIP messages.

## Examples

The following examples illustrate several formats for specifying the call-agent and service type (use any one of these formats):

```
Router(config)# mgcp call-agent 209.165.200.225 service-type sgcp version 1.5
Router(config)# mgcp call-agent 209.165.200.225 5530 service-type mgcp
Router(config)# mgcp call-agent igloo service-type sgcp
Router(config)# mgcp call-agent igloo 2009 service-type mgcp version 0.1
```

Related Commands	Command	Description
	<a href="#">mgcp</a>	Starts the MGCP daemon.
	<a href="#">mgcp sgcp restart notify</a>	Starts RSIP message processing in the MGCP application.

# mgcp codec

To select the default codec type and its packetization period value, use the **mgcp codec** global configuration command. To set the parameters to their default values, use the **no** form of this command.

**mgcp codec** *type* **packetization-period** *value*

**no mgcp codec**

## Syntax Description

<i>type</i>	The types of codec supported. Valid codecs include <b>G711alaw</b> , <b>G711ulaw</b> , <b>G723ar53</b> , <b>G723ar63</b> , <b>G723r53</b> , <b>G723r63</b> , <b>G726r16</b> , <b>G726r24</b> , <b>G726r32</b> , <b>G729ar8</b> , <b>G729br8</b> , <b>G729r8</b> .
<b>packetization-period</b> <i>value</i>	This parameter is useful when the preferred compression algorithm and/or packetization period parameter is not provided by the Media Gateway Controller (call agent). The value range (in milliseconds) depends on the type of codec selected.  For example, the range for G729r8 is 10 to 220 ms in increments of 10. For G711ulaw, the range is 10 to 20 ms in increments of 10. For G723ar63, the range is 30 to 270 ms in increments of 30.

## Defaults

G711ulaw

## Command Modes

Global configuration

## Command History

Release	Modification
12.1(1)T	This command was introduced for the Cisco AS5300.
12.1(3)T	Support for this command was extended to the Cisco 3660, Cisco uBR924, and Cisco 2600 series platforms.
12.1(5)XM	Support for this command was extended to the Cisco MC3810 series platform.

## Examples

The following example illustrates setting the codec type to g729r8 with a packetization period of 150:

```
Router(config)# mgcp codec g729r8 packetization-period 150
```

## Related Commands

Command	Description
<a href="#">mgcp</a>	Starts the MGCP daemon.

# mgcp default-package

To configure the default package capability type for the media gateway, use the **mgcp default-package** global configuration command.

This command does not support a **no** form. To change the default package, use the **mgcp default-package** command with a different, actively supported package.

For a residential gateway (RGW):

```
mgcp default-package {dt-package | dtmf-package | gm-package | hs-package | line-package |
ms-package | rtp-package}
```

For a trunking gateway (TGW):

```
mgcp default-package {as-package | atm-package | dt-package | dtmf-package | gm-package |
hs-package | mo-package | ms-package | nas-package | rtp-package | script-package |
trunk-package}
```

## Syntax Description

<b>as-package</b>	Announcement server package.
<b>atm-package</b>	ATM package.
<b>dt-package</b>	DTMF Trunk package (for CAS endpoints).
<b>dtmf-package</b>	DTMF package.
<b>gm-package</b>	Generic media package.
<b>hs-package</b>	Handset package.
<b>line-package</b>	Line package.
<b>mo-package</b>	MF Operator services package (for CAS endpoints).
<b>ms-package</b>	MF wink/immediate Start package (for CAS endpoints).
<b>nas-package</b>	Network Access Server package.
<b>rtp-package</b>	RTP package.
<b>script-package</b>	Script package.
<b>trunk-package</b>	Trunk package.

## Defaults

For RGW: line-package  
For TGW: trunk-package

## Command Modes

Global configuration

**Command History**

Release	Modification
12.0(7)XR2, 12.1(1)T	This command was introduced for the Cisco AS5300.
12.1(3)T	The <b>line-package</b> option and a distinction between residential and trunking gateways were added.
12.1(5)XM	This command was expanded to the Cisco MC3810 series and Cisco 3600 platforms. <b>atm-package</b> , <b>hs-package</b> , <b>ms-package</b> , <b>dt-package</b> , and <b>mo-package</b> were added.

**Usage Guidelines**

This command is helpful when the Media Gateway Controller (call agent) does not provide the package capability to be used for the given connection. A “package” is a set of parameter values defined for a particular type of endpoint or connection.

Before selecting a package as the default, use the **show mgcp** command to ensure the package is actively supported. If the package you want does not appear in the display, use the **mgcp package-capability** command to add the package to the supported list.

**Note**

The CAS packages (**dt-package**, **mo-package**, and **ms-package**) are available only as default package options. They do not appear as options in **mgcp package-capability**. The reason is that the non-CAS packages are configured on a per-gateway basis, while the CAS packages are defined on a per-trunk basis. Each trunk is defined using the **ds0-group** command.

If only one package is actively supported, it becomes the default package.

**Examples**

```
Router(config)# mgcp default-package as-package
as-package type will be the new default package type.
```

**Related Commands**

Command	Description
<b>mgcp package-capability</b>	Includes a specific MGCP package that is supported by the gateway.
<b>mgcp</b>	Starts the MGCP daemon.

# mgcp dtmf-relay

To ensure accurate forwarding of digits on compressed codecs, use the **mgcp dtmf-relay** command. To disable this process for non-compressed codecs, use the **no** form of this command.

## Voice over IP

```
mgcp dtmf-relay voip codec {all | low-bit-rate} mode {cisco| nse | out-of-band}
```

```
no mgcp dtmf-relay voip
```

## Voice over AAL2

```
mgcp dtmf-relay voaal2 codec [all | low-bit-rate]
```

```
no mgcp dtmf-relay voaal2
```

### Syntax Description

<b>voip</b>	Specifies Voice over IP calls.
<b>voaal2</b>	Specifies Voice over AAL2 calls (using Annex K type 3 packets).
<b>all</b>	Specifies use of any codec.
<b>low-bit-rate</b>	Specifies any version of the G.729 low-bit-rate codecs.
<b>cisco</b>	This mode removes dtmf tone from the voice stream and sends FRF.11 with a special payload 121 for dtmf digits.
<b>nse</b>	Uses the NSE-based forwarding method.
<b>out-of-band</b>	This mode removes dtmf tone from the voice stream and does not send FRF.11.

### Defaults

no dtmf-relay for all codecs

### Command Modes

Controller configuration

### Command History

Release	Modification
12.1(3)T	This command was added to MGCP.
12.1(5)XM	Support for this command was expanded to include the Cisco MC3810 series platform.

### Usage Guidelines

Only VoIP supports the **mode** options for forwarding digits on codecs.

### Examples

The following example shows how to configure a codec for VoAAL2:

```
Router(config)# mgcp dtmf-relay voaal2 codec all
```

The following example shows how to configure a low-bit-rate codec using VoIP in nse mode:

```
Router(config)# mgcp dtmf-relay voip codec low-bit-rate mode nse
```

---

**Related Commands**

Command	Description
<a href="#">mgcp</a>	Starts the MGCP daemon.

---

# mgcp explicit hookstate

To enable detection of explicit hookstates, use the **mgcp explicit hookstate** global configuration command. To disable the hookstate detection, use the no form of the command.

**mgcp explicit hookstate**

**no mgcp explicit hookstate**

**Syntax Description** This command has no keywords or arguments.

**Defaults** Enabled (hookstate detection is enabled)

**Command Modes** Global configuration

Command History	Release	Modification
	12.1(5)XM	This command was introduced.

**Usage Guidelines** Explicit hookstate detection is enabled, by default. In this state, the gateway returns a “401 endpoint already off hook” or “402 endpoint already on hook” NACK (Not Acknowledged) response to R:hu or R:hd event requests.

If you turn hookstate detection off with **no mgcp explicit hookstate**, the hookstate is not checked when the gateway receives R:hu or R:hd event requests. The gateway will acknowledge (ACK) these event requests.

**Examples** The following example illustrates how to enable the hookstate detection:

```
Router(config)# mgcp explicit hookstate
```

Related Commands	Command	Description
	<a href="#">mgcp</a>	Starts the MGCP daemon.

## mgcp ip-tos

To enable or disable the IP Type of Services (TOS) for MGCP-controlled connections, use the **mgcp ip-tos** global configuration command. To set the parameters to their default values, use the **no** form of this command.

**mgcp ip-tos** { **high-reliability** | **high-throughput** | **low-cost** | **low-delay** | **rtp precedence** *value* | **signaling precedence** *value* }

**no mgcp ip-tos** { **high-reliability** | **high-throughput** | **low-cost** | **low-delay** | **rtp precedence** *value* | **signaling precedence** *value* }

### Syntax Description

<b>high-reliability</b>	Specifies high-reliability TOS.
<b>high-throughput</b>	Specifies high-throughput TOS.
<b>low-cost</b>	Specifies low-cost TOS.
<b>low-delay</b>	Specifies low-delay TOS.
<b>rtp precedence</b> <i>value</i>	Specifies the IP precedence value for MGCP-controlled RTP packets. Valid values are from 0 to 7. The default is 5.  <b>Note</b> In Cisco IOS Release 12.1(3)T, this parameter was <b>precedence</b> <i>value</i> .
<b>signaling precedence</b> <i>value</i>	Specifies the IP precedence value for MGCP UDP and RTCP signaling packets. Valid values are from 0 to 7. The default is 3.

### Defaults

Services disabled.

The default for the **rtp precedence** value is 5.

The default for the **signaling precedence** value is 3.

### Command Modes

Global configuration

### Command History

Release	Modification
12.1(1)T	This command was introduced for the Cisco AS5300.
12.1(3)T	Support for this command was extended to the Cisco 3660, Cisco uBR924, and Cisco 2600 series platforms.
12.1(5)XM	Support for this command was extended to the Cisco MC3810 series platform, the <b>precedence</b> parameter was changed to <b>rtp precedence</b> , and the <b>signaling precedence</b> parameter was added.

### Usage Guidelines

Only one of the high-reliability, high-throughput, low-cost, or low-delay parameters can be enabled at any given time. Enabling one parameter disables any other that was active. This has no effect on the two **precedence** parameters.

When you configure a new value for a **precedence** value, the old value is erased.

The **no** form of the **mgcp ip-tos** command disables the first four parameters and sets the **precedence** values back to their defaults.

---

**Examples**

In the following example, activating **low-delay** disables the other three parameters.

```
Router(config)# mgcp ip-tos high-rel
Router(config)# mgcp ip-tos high-throughput
Router(config)# mgcp ip-tos low-cost
Router(config)# mgcp ip-tos low-delay
Router(config)# mgcp ip-tos rtp precedence 4
Router(config)# mgcp ip-tos signaling precedence 5
```

---

**Related Commands**

Command	Description
<a href="#">mgcp</a>	Starts the MGCP daemon.

# mgcp modem passthrough codec

To select the codec that enables the gateway to send and receive modem and fax data in VoIP and VoAAL2 configurations, use the **mgcp modem passthrough codec** command. To disable support for modem and fax data, use the **no** form of this command.

```
mgcp modem passthrough {voip | voaal2} codec {g711alaw | g711ulaw}
```

```
no mgcp modem passthrough {voip | voaal2}
```

## Syntax Description

<b>voip</b>	Uses Voice over IP as the voice protocol.
<b>voaal2</b>	Uses Voice over AAL2 as the voice protocol.
<b>g711alaw</b>	Uses the G711aLaw codec for changing speeds during modem/fax switchover.
<b>g711ulaw</b>	Uses the G711uLaw codec for changing speeds during modem/fax switchover.

## Defaults

**g711ulaw** for both **voip** and **voaal2**

## Command Modes

Controller configuration

## Command History

Release	Modification
12.1(3)T	This command was added to MGCP.
12.1(5)XM	Support for the Cisco MC3810 series platform was added.

## Usage Guidelines

Use this command for fax passthrough since the answer tone can come from either modem or FAX transmissions. Selecting a codec will dynamically change the codec type and speed to meet network conditions.

## Examples

The following example illustrates how to enable a gateway to send and receive VoAAL2 modem or fax data using the G711alaw codec:

```
Router(config)# mgcp modem passthrough voaal2 codec g711alaw
```

## Related Commands

Command	Description
<a href="#">mgcp</a>	Starts the MGCP daemon.
<a href="#">mgcp tse payload</a>	Enables the TSE payload for modem/fax operation.
<a href="#">mgcp modem passthrough mode</a>	Sets the method for changing speeds for modem and fax transmissions on the gateway.
<a href="#">mgcp modem passthrough voip redundancy</a>	Enables redundancy for VoIP modem and fax transmissions.

# mgcp modem passthrough mode

To set the method for changing speeds that enables the gateway to send and receive modem and fax data in VoIP and VoAAL2 configurations, use the **mgcp modem passthrough mode** command. To disable support for modem and fax data, use the **no** form of this command.

```
mgcp modem passthrough { voip | voaal2 } mode { cisco | nse }
```

```
no mgcp modem passthrough { voip | voaal2 }
```

## Syntax Description

<b>voip</b>	Uses Voice over IP as the voice protocol.
<b>voaal2</b>	Uses Voice over AAL2 as the voice protocol.
<b>cisco</b>	Uses Cisco's proprietary method for changing modem speeds, based on the protocol. This method is not available for VoAAL2 configurations.
<b>nse</b>	Uses the NSE-based method for changing modem speeds. For VoAAL2 configurations, the AAL2 Annex K (Type 3) is used.

## Defaults

**nse** for both **voip** and **voaal2**

## Command Modes

Controller configuration

## Command History

Release	Modification
12.1(3)T	This command was added to MGCP.
12.1(5)XM	Support for the Cisco MC3810 series platform was added.

## Usage Guidelines

Use this command for fax passthrough since the answer tone can come from either modem or fax transmissions. The upspeed method is the method used to dynamically change the codec type and speed to meet network conditions.

If you use the **nse** option, you must also configure the [mgcp tse payload](#) command.

If you use the default **nse** option for either **voip** or **voaal2**, the **show run** command does *not* display **mgcp modem passthrough mode** in the configuration output. The **mgcp modem passthrough mode** command is displayed in the configuration output for the **cisco** option. However, the **show mgcp** command displays the settings for both **nse** and **cisco**.

## Examples

The following example illustrates how to enable a gateway to send and receive VoIP modem or fax data using the NSE modem speed changing method:

```
Router(config)# mgcp modem passthrough voip mode nse
```

Related Commands	Command	Description
	<a href="#">mgcp</a>	Starts the MGCP daemon.
	<a href="#">mgcp tse payload</a>	Enables the TSE payload for modem/fax operation.
	<a href="#">mgcp modem passthrough codec</a>	Selects the codec to use for modem and fax transmissions on the gateway.
	<a href="#">mgcp modem passthrough voip redundancy</a>	Enables redundancy for VoIP modem and fax transmissions.

# mgcp modem passthrough voip redundancy

To enable redundancy on a gateway that sends and receives modem and fax data in VoIP configurations, use the **mgcp modem passthrough voip redundancy** command. To disable support for modem and fax data, use the **no** form of this command.

**mgcp modem passthrough voip redundancy**

**no mgcp modem passthrough voip redundancy**

**Syntax Description** This command has no keywords or arguments.

**Defaults** Disabled

**Command Modes** Controller configuration

Command History	Release	Modification
	12.1(5)XM	This command was introduced.

**Usage Guidelines** Use this command for fax passthrough because the answer tone can come from either modem or FAX transmissions. The upspeed method is the method used to dynamically change the codec type and speed to meet network conditions.

**Examples** The following example illustrates how to enable redundancy for VoIP modem and fax transmissions on a gateway:

```
Router(config)# mgcp modem passthrough voip redundancy
```

Related Commands	Command	Description
	<a href="#">mgcp</a>	Starts the MGCP daemon.
	<a href="#">mgcp tse payload</a>	Enables the TSE payload for modem/fax operation.
	<a href="#">mgcp modem passthrough codec</a>	Selects the codec for modem and fax transmissions.
	<a href="#">mgcp modem passthrough mode</a>	Selects the upspeed method for modem and fax transmission.

# mgcp package-capability

To specify an MGCP package capability for this gateway, use the **mgcp package-capability** global configuration command. To remove a specific MGCP package capability from the list of capabilities, use the **no** form of this command.

## All RGWs

```
mgcp package-capability { dtmf-package | gm-package | hs-package | line-package |
  rtp-package }
```

```
no mgcp package-capability { dtmf-package | gm-package | hs-package | line-package |
  rtp-package }
```

## Cisco AS5300 TGW

```
mgcp package-capability { as-package | atm-package | dtmf-package | gm-package | hs-package
  | nas-package | rtp-package | script-package | trunk-package }
```

```
no mgcp package-capability { as-package | dtmf-package | gm-package | hs-package |
  nas-package | rtp-package | script-package | trunk-package }
```

## Non-Cisco AS5300 TGWs

```
mgcp package-capability { as-package | dtmf-package | gm-package | hs-package | nas-package
  | rtp-package | trunk-package }
```

```
no mgcp package-capability { as-package | dtmf-package | gm-package | hs-package |
  nas-package | rtp-package | trunk-package }
```

## Syntax Description

<b>as-package</b>	Announcement server package
<b>atm-package</b>	ATM package
<b>dtmf-package</b>	DTMF package
<b>gm-package</b>	Generic media package
<b>hs-package</b>	Handset package
<b>line-package</b>	Line package
<b>nas-package</b>	Network Access Server package
<b>rtp-package</b>	RTP package
<b>script-package</b>	Script package
<b>trunk-package</b>	Trunk package

## Defaults

For all RGWs: **line-package**

For all TGWs: **trunk-package**

## Command Modes

Global configuration

Command History	Release	Modification
	12.1(1)T	This command was introduced for the Cisco AS5300 platform.
	12.1(3)T	The command was expanded to the Cisco uBR924, Cisco 2600 series, and Cisco 3660 platforms. <b>line-package</b> , <b>rtp-package</b> , and <b>script-package</b> were added.
	12.1(5)XM	This command was expanded to the Cisco MC3810 series platform.

### Usage Guidelines

Select packages supported by your call agent. Events specified in the MGCP messages from the call agent must belong to one of the supported packages. Otherwise, the connection requests are refused by the gateway.

Use this command before specifying a default package with the **mgcp default-package** command. Specify at least one package to have a default.



**Note** The CAS packages (**dt-package**, **mo-package**, and **ms-package**) are available only as default package options. They do not appear as options in **mgcp package-capability**. The reason for this is that all the other packages are configured on a per-gateway basis, while the CAS packages are defined on a per-trunk basis. The per-trunk definition is done when the trunk is configured using the **ds0-group** command.

Enter each package as a separate command.

### Examples

The following examples illustrate how to set different packages on the gateway and to designate one as the default package:

```
Router(config)# mgcp package-capability trunk-package
Router(config)# mgcp package-capability dtmf-package
Router(config)# mgcp package-capability script-package
Router(config)# mgcp default-package trunk-package
```

### Related Commands

Command	Description
<b>mgcp default-package</b>	Configures the default package capability type for the media gateway.
<b>mgcp</b>	Starts the MGCP daemon.

## mgcp quality-threshold

To set the jitter buffer size threshold, latency threshold, and packet-loss threshold parameters, use the **mgcp quality-threshold** global configuration command. To restore the default parameter values, use the **no** form of this command.

```
mgcp quality-threshold { hwm-cell-loss value | hwm-jitter-buffer value | hwm-latency value |
hwm-packet-loss value | lwm-cell-loss value | lwm-jitter-buffer value | lwm-latency value |
lwm-packet-loss value }
```

```
no mgcp quality-threshold { hwm-jitter-buffer | hwm-latency | hwm-packet-loss |
lwm-jitter-buffer | lwm-latency | lwm-packet-loss }
```

### Syntax Description

<b>hwm-cell-loss</b> <i>value</i>	This parameter is available when the ATM package is enabled. Specifies the high-water-mark cell loss count. Valid range is 5,000 to 25,000, and the default value is 10,000.
<b>hwm-jitter-buffer</b> <i>value</i>	Specifies the high-water-mark jitter buffer size. Valid range is from 100 to 200, and the default value is 150.
<b>hwm-latency</b> <i>value</i>	Specifies the high-water-mark latency value. Valid range is from 250 to 400, and the default value is 300.
<b>hwm-packet-loss</b> <i>value</i>	Specifies the high-water-mark packet-loss value. Valid range is from 5,000 to 25,000, and the default value is 10,000.
<b>lwm-cell-loss</b> <i>value</i>	This parameter is available when the ATM package is enabled. Specifies the low-water-mark cell loss count. Valid range is from 1 to 3,000, and the default value is 1,000.
<b>lwm-jitter-buffer</b> <i>value</i>	Specifies the low-water-mark jitter buffer size. Valid range is from 4 to 60, and the default value is 30.
<b>lwm-latency</b> <i>value</i>	Specifies the low-water-mark latency value. Valid range is from 125 to 200, and the default value is 150.
<b>lwm-packet-loss</b> <i>value</i>	Specifies the low-water-mark packet-loss value. Valid range is from 1 to 3,000, and the default value is 1,000.

### Defaults

The voice quality parameter defaults are (in milliseconds): **hwm-cell-loss** 10000, **hwm-jitter-buffer** 150, **hwm-latency** 300, **hwm-packet-loss** 10000, **lwm-cell-loss** 1000, **lwm-jitter-buffer** 30, **lwm-latency** 300, and **lwm-packet-loss** 1000.

### Command Modes

Global configuration

**Command History**

Release	Modification
11.3(3)T	The default was changed to 100 milliseconds.
12.1(1)T	This command was introduced for the Cisco AS5300.
12.1(3)T	Support for this command was extended to the Cisco 3660, Cisco uBR924, and Cisco 2600 series platforms.
12.1(5)XM	Support for this command was extended to the Cisco MC3810 series platform and the <b>hwm-cell-loss</b> and <b>lwm-cell-loss</b> parameters were added.

**Usage Guidelines**

The following parameters impact the quality of voice calls:

- **cell loss** (the number of ATM cells lost during transmission)
- **jitter buffer** (storage area containing active call voice packets that have been received from the network and are waiting to be decoded and played)
- **packet loss** (number of packets lost per 100,000 packets for a given call)
- **latency** (network delay in sending/receiving packets)

For good voice quality, the system should perform below the **lwm** values. As the values go higher, voice quality degrades. The system generates a report when the values go above the **hwm** levels. Set the **hwm** and **lwm** values sufficiently apart so that you receive reports on poor performance, but not so close together that you receive too much feedback.

Enter each parameter as a separate command.

**Examples**

The following examples show how the different parameters can be set to new values:

```
Router(config)# mgcp quality-threshold hwm-cell-loss 7500
Router(config)# mgcp quality-threshold lwm-cell-loss 2000
Router(config)# mgcp quality-threshold hwm-jit 100
Router(config)# mgcp quality-threshold hwm-lat 250
Router(config)# mgcp quality-threshold hwm-pack 5000
Router(config)# mgcp quality-threshold lwm-jit 50
Router(config)# mgcp quality-threshold lwm-lat 200
Router(config)# mgcp quality-threshold lwm-pack 20
```

**Related Commands**

Command	Description
<b>mgcp playout</b>	Tunes the jitter buffer packet size.
<b>mgcp package-capability</b>	Activates various packages on the gateway.
<b>mgcp</b>	Starts the MGCP daemon.

## mgcp quarantine mode

To set the parameters for handling SGCP call events in the quarantine buffer, use the **mgcp quarantine mode** global configuration command. To restore the default value, use the **no** form of the command.

**mgcp quarantine mode** [**discard** | **process**] [**loop** | **step**]

**no mgcp quarantine mode**

### Syntax Description

<b>discard</b>	(Optional) Observed events are not reported to the call agent, even if the CA is ready to receive them.
<b>process</b>	(Optional) Observed events are reported to the call agent when the CA is ready to receive them.
<b>loop</b>	(Optional) The gateway reports observed events to the call agent in groups.
<b>step</b>	(Optional) The gateway reports observed events individually to the call agent.

### Defaults

**discard** and **step**

### Command Modes

Global configuration

### Command History

Release	Modification
12.1(5)XM	This command was introduced.

### Usage Guidelines

This command supports backward compatibility with SGCP implementations running under the MGCP application. SGCP does not have a way to allow the call agent to control the quarantine mode, which determines whether a gateway will send observed events to the call agent when the CA indicates readiness to receive them. MGCP has this functionality.

### Examples

The following example shows how to send observed events to the call agent:

```
Router(config)# mgcp quarantine mode process
```

The following example shows how to send observed events to the call agent in loop mode:

```
Router(config)# mgcp quarantine mode process loop
```

Related Commands	Command	Description
	<a href="#">mgcp</a>	Starts the MGCP daemon.
	<a href="#">mgcp quarantine persistent-events disable</a>	Disables handling of persistent SGCP call events in the quarantine buffer.

# mgcp quarantine persistent-events disable

To disable handling of persistent SGCP call events in the quarantine buffer, use the **mgcp quarantine persistent-events disable** global configuration command. To restore the default value, use the **no** form of the command.

**mgcp quarantine persistent-events disable**

**no mgcp quarantine persistent-events disable**

## Syntax Description

This command has no keywords or arguments.

## Defaults

No defaults (persistent events are held in the quarantine buffer)

## Command Modes

Global configuration

## Command History

Release	Modification
12.1(5)XM	This command was introduced.

## Usage Guidelines

This command reports persistent events immediately to the call agent by a Notify command rather than holding them in quarantine. By default, all events, including persistent events, are quarantined when they are detected even though the gateway is in notification state.

## Examples

The following example shows how to turn off quarantine buffer handling of persistent events:

```
Router(config)# mgcp quarantine persistent-event disable
```

## Related Commands

Command	Description
<a href="#">mgcp</a>	Starts the MGCP daemon.
<a href="#">mgcp quarantine mode</a>	Sets the parameters for handling SGCP call events in the quarantine buffer.

# mgcp request retries

To specify the number of times to retry sending the **mgcp** command, use the **mgcp request retries** global configuration command. To restore the default value, use the **no** form of this command.

**mgcp request retries** *count*

**no mgcp request retries**

<b>Syntax Description</b>	<i>count</i>	Specifies the number of times a Notify message is retransmitted to the call agent before the request is dropped. The valid range is 1 to 10.
---------------------------	--------------	--

<b>Defaults</b>	3 times
-----------------	---------

<b>Command Modes</b>	Global configuration
----------------------	----------------------

<b>Command History</b>	<b>Release</b>	<b>Modification</b>
	12.1(1)T	This command was introduced for the Cisco AS5300.
	12.1(3)T	Support for this command was extended to the Cisco 3660, Cisco uBR924, and Cisco 2600 series platforms.
	12.1(5)XM	Support for this command was extended to the Cisco MC3810 series platform.

<b>Usage Guidelines</b>	This command applies to a trunking gateway.
-------------------------	---

**Examples** The following example will set the system will try to send the **mgcp** command 10 times before dropping the request:

```
Router(config)# mgcp request retries 10
```

<b>Related Commands</b>	<b>Command</b>	<b>Description</b>
	<a href="#">mgcp request timeout</a>	Specifies how long the system will wait for a reply to a request.
	<a href="#">mgcp</a>	Starts the MGCP daemon.

## mgcp request timeout

To specify how long the system waits for a response to a request, use the **mgcp request timeout** global configuration command. To restore the default value, use the **no** form of this command.

**mgcp request timeout** *timeout*

**no mgcp request timeout**

<b>Syntax Description</b>	<i>timeout</i>	Specifies the number of milliseconds to wait for a response to a request. Valid range is 1 to 10,000 (10 seconds).
---------------------------	----------------	--

<b>Defaults</b>	500 milliseconds
-----------------	------------------

<b>Command Modes</b>	Global configuration
----------------------	----------------------

<b>Command History</b>	<b>Release</b>	<b>Modification</b>
	12.1(1)T	This command was introduced for the Cisco AS5300.
12.1(3)T	Support for this command was extended to the Cisco 3660, Cisco uBR924, and Cisco 2600 series platforms.	
12.1(5)XM	Support for this command was extended to the Cisco MC3810 series platform.	

**Examples** The following example sets the system to wait 40 milliseconds for a reply to a request:

```
Router(config)# mgcp request timeout 40
```

<b>Related Commands</b>	<b>Command</b>	<b>Description</b>
	<a href="#">mgcp request retries</a>	Specifies the number of times to retry sending the <b>mgcp</b> command.
	<a href="#">mgcp</a>	Starts the MGCP daemon.

# mgcp restart-delay

To select the delay value sent in the RSIP graceful tear down, use the **mgcp restart-delay** global configuration command. To restore the default value, use the **no** form of this command.

**mgcp restart-delay** *value*

**no mgcp restart-delay**

Syntax Description	<i>value</i>	Specifies the restart delay value in seconds. Valid range is from 0 to 600.
--------------------	--------------	---

Defaults	0 seconds
----------	-----------

Command Modes	Global configuration
---------------	----------------------

Command History	Release	Modification
	12.1(1)T	This command was introduced for the Cisco AS5300.
	12.1(3)T	Support for this command was extended to the Cisco 3660, Cisco uBR924, and Cisco 2600 series platforms.
	12.1(5)XM	Support for this command was extended to the Cisco MC3810 series platform.

Usage Guidelines	Use the restart value to send a restart in progress (RSIP) message indicating when the connection in the gateway will be torn down.
------------------	---

Examples	The following example shows how to set the restart delay to 30 seconds:
----------	---

```
Router(config)# mgcp restart-delay 30
```

Related Commands	Command	Description
	<a href="#">mgcp</a>	Starts the MGCP daemon.
	<a href="#">mgcp max-waiting-delay</a>	Specifies the MGCP maximum waiting delay (MWD) after a restart.

# mgcp sgcp restart notify

To trigger the MGCP application to process SGCP-type RSIP messages, use the **mgcp sgcp restart** configuration command. Use the **no** form of this command to restore the default value.

**mgcp sgcp restart notify**

**no mgcp sgcp restart notify**

**Syntax Description** This command has no keywords or arguments.

**Defaults** No defaults

**Command Modes** Global configuration

Command History	Release	Modification
	12.1(3)T	This command was introduced for the Cisco 3600 series router.
	12.1(5)XM	This command was modified for MGCP and expanded to the Cisco MC3810 series platform.

**Usage Guidelines** This command is used to send RSIP (Restart in progress) messages from the router to the SGCP call agent. The RSIP messages are used to indicate whether the T1 controller is up or down so that the call agent can synchronize with the router. RSIP messages are also sent when the **mgcp** command is entered, enabling the MGCP daemon.

**Examples** The following example specifies that the system sends an RSIP notification to the SGCP call agent when the T1 controller state changes:

```
Router(config)# mgcp sgcp restart notify
```

Related Commands	Command	Description
	<a href="#">mgcp</a>	Starts the MGCP daemon.

# mgcp timer

To configure how the gateway detects the RTP stream host, use the **mgcp timer** configuration command. Use the **no** form of this command to restore the default value.

```
mgcp timer { receive-rtcp timer | net-cont-test timer }
```

```
no mgcp timer { receive-rtcp | net-cont-test }
```

## Syntax Description

<b>receive-rtcp timer</b>	Sets multiples of the RTCP transmission interval in milliseconds. The valid range is 1 to 100, and the default is 5. This parameter is valid only for VoIP calls.
<b>net-cont-test timer</b>	Sets the continuity test timeout in milliseconds. The valid range is 100 to 3,000, and the default is 200. This parameter is valid for VoIP and VoAAL2 calls.
<b>Note</b>	This option was previously named <b>rtp-nse</b> .

## Defaults

**receive-rtcp timer** default is 5  
**net-cont-test timer** default is 200

## Command Modes

Global configuration

## Command History

Release	Modification
12.0(5)T	This command was introduced as SGCP on the Cisco AS5300.
12.0(7)XK	Support for this command was extended to the Cisco MC3810 series and Cisco 3600 series routers (except for the Cisco 3620).
12.1(5)XM	The command was modified to support MGCP. The option <b>rtp-nse</b> was changed to <b>net-cont-test</b> . Functionality was not changed, only the option name.

## Usage Guidelines

**receive-rtcp** is the timer used by a gateway to disconnect a VoIP call when the IP connectivity is lost with the remote gateway. After receiving each packet from the remote gateway, the receiving gateway starts a timer for the *timer* period. If the timer expires before receiving the next packet from the remote gateway, the receiving gateway will disconnect the call and notify the call agent.

**net-cont-test** uses the terminating gateway to verify the network connectivity with the originating gateway before ringing the called party. To do this, the terminating gateway sends a command packet to the originating gateway and starts a timer for the *timer* period. If the timer expires before receiving any acknowledgement from the originating gateway, the terminating gateway will not ring the called party, will disconnect the call, and will alert the call agent.

**Examples**

The following example sets the receive-rtcp timer to 25 milliseconds:

```
Router(config)# mgcp timer receive-rtcp 25
```

The following example sets the net-cont-test timer to 1500 milliseconds (1.5 seconds):

```
Router(config)# mgcp timer net-cont-test 1500
```

**Related Commands**

Command	Description
<a href="#">mgcp</a>	Starts the MGCP daemon.
<a href="#">mgcp modem passthrough mode</a>	Sets the upspeed method for fax and modem calls.
<a href="#">mgcp tse payload</a>	Sets the TSE payload for fax and modem calls.

# mgcp tse payload

To specify the DSP payload value to be used during fax/modem passthrough and the network continuity test, use the **mgcp tse payload** configuration command. Use the **no** form of this command to restore the default value.

**mgcp tse payload** *value*

**no mgcp tse payload**

<b>Syntax Description</b>	<i>value</i>	Sets the TSE payload value. The valid range is 98 to 119. The default is 0, meaning the command is disabled.
---------------------------	--------------	--

<b>Defaults</b>	0
-----------------	---

<b>Command Modes</b>	Global configuration
----------------------	----------------------

<b>Command History</b>	<b>Release</b>	<b>Modification</b>
	12.0(7)XK	This command was introduced for SGCP on the Cisco MC3810 series and Cisco 3600 series routers (except the Cisco 3620).
	12.1(5)XM	This command was modified for MGCP.

<b>Usage Guidelines</b>	<p>Because this command is disabled by default, you must specify a TSE payload type.</p> <p>If you configure the <b>mgcp modem passthrough mode</b> command to the <b>nse</b> value, then you must configure this command.</p>
-------------------------	--

<b>Examples</b>	<p>The following example illustrates setting the nse mode for VoIP modem passthrough and setting the TSE payload:</p>
-----------------	---

```
Router(config)# mgcp modem passthrough voip mode nse
Router(config)# mgcp tse payload 100
```

<b>Related Commands</b>	<b>Command</b>	<b>Description</b>
	<a href="#">mgcp</a>	Starts the MGCP daemon.
	<a href="#">mgcp modem passthrough mode</a>	Sets the upspeed method for fax and modem messages.

# mgcp vad

To set the default voice activity detection (VAD) parameter for MGCP, use the **mgcp vad** global configuration command. To disable the VAD parameter, use the **no** form of this command.

**mgcp vad**

**no mgcp vad**

**Syntax Description** This command has no arguments or keywords.

**Defaults** Disabled

**Command Modes** Global configuration

## Command History

Release	Modification
12.1(1)T	This command was introduced for the Cisco AS5300.
12.1(3)T	Support for this command was extended to the Cisco 3660, Cisco uBR924, and Cisco 2600 series platforms.
12.1(5)XM	Support for this command was extended to the Cisco MC3810 series platform.

## Usage Guidelines

Use the MGCP voice activity detection (VAD) parameter to tell the MGCP gateway to turn silence suppression on or off.

If VAD is turned on, silence is not sent over the network, only audible speech. The sound quality will be slightly degraded but the connection will monopolize much less bandwidth.

## Examples

The following example shows how to turn silence suppression on:

```
Router(config)# mgcp vad
```

## Related Commands

Command	Description
<a href="#">mgcp</a>	Starts the MGCP daemon.

## mode (Voice over ATM)

To set the mode of the T1/E1 controller and enter specific configuration commands for each mode type, use the **mode** command in controller configuration mode. Use the **no** form of this command to restore the default mode of the controller.

```
mode { atm | cas }
```

```
no mode { atm | cas }
```

Syntax Description		
<b>atm</b>	Sets the controller into ATM mode and creates an ATM interface (ATM 0) on the Cisco MC3810 series platform. When ATM mode is enabled, no channel groups, CAS groups, CCS groups, or clear channels are allowed because ATM occupies all the DS-0s on the T1/E1 trunk.	
	When you set the controller to ATM mode, the controller framing is automatically set to ESF for T1 or CRC4 for E1. The linecode is automatically set to B8ZS for T1 or HDLC for E1. When you remove ATM mode by entering the <b>no mode atm</b> command, ATM interface 0 is deleted.	
	ATM mode is supported only on controller 0 (T1 or E1 0).	
<b>cas</b>	Sets the controller into channel-associated signaling (CAS) mode, which allows you to create channel groups, CAS groups, and clear channels (both data and CAS modes).	
	CAS mode is supported on both controllers 0 and 1.	

Defaults	
No mode is configured.	

Command Modes	
Controller configuration	

Command History	Release	Modification
	11.3 MA	This command was introduced.
	12.1(5)XM	Support for this command was extended to the merged SGCP/MGCP software.

Usage Guidelines	
This command applies to the Cisco MC3810 series platform with the digital voice module (DVM) installed.	

When no mode is selected, channel groups and clear channels (data mode) can be created using the channel group and tdm-group commands, respectively.

On the Cisco MC3810 series platform, some DS-0s are used exclusively for different signaling modes. The DS-0 channels have the following limitations when mixing different applications (such as voice and data) on the same network trunk:

- On E1 controllers, DS-0 16 is used exclusively for either CAS or CCS, depending on which mode is configured.
- On T1 controllers, DS-0 24 is used exclusively for CCS.

### Examples

The following example configures ATM mode on controller T1 0. This step is required for Voice over ATM.

```
Router(config)# controller T1 0
Router(config-controller)# mode atm
```

The following example configures CAS mode on controller T1 1:

```
Router(config)# controller T1 1
Router(config-controller)# mode cas
```

### Related Commands

Command	Description
<b>channel-group</b>	Defines the time slots that belong to each T1 or E1 circuit.
<b>tdm-group</b>	Configures a list of time slots for creating clear channel groups (pass-through) for TDM cross-connect.
<b>voice-group</b>	Configures a list of time slots for voice CAS on the T1/E1 controller on the Cisco MC3810 series multiservice concentrator.

## pvc

To create or assign a name to an ATM permanent virtual circuit (PVC), specify the encapsulation type on an ATM PVC, or enter interface-ATM-VC configuration mode, use the **pvc** command in interface or subinterface configuration mode. To remove an ATM PVC, use the **no** form of this command.

```
pvc [name] vpi/vci [ilmi | qsaal | smds]
```

```
no pvc [name] vpi/vci [ilmi | qsaal | smds]
```

### Syntax Description

<i>name</i>	(Optional) The name of the PVC or map. The name can be up to 16 characters long.
<i>vpi/</i>	<p>ATM network virtual path identifier (VPI) for this PVC. The absence of the "/" and a <i>vpi</i> value defaults the <i>vpi</i> value to 0.</p> <p>On the Cisco 7200 and 7500 series routers, this value ranges from 0 to 255; on the Cisco 4500 and 4700 routers, this value ranges from 0 to 1 less than the quotient of 8192 divided by the value set by the <b>atm vc-per-vp</b> command.</p> <p>The arguments <i>vpi</i> and <i>vci</i> cannot both be set to 0; if one is 0, the other cannot be 0.</p>
<i>vci</i>	<p>ATM network virtual channel identifier (VCI) for this PVC. This value ranges from 0 to 1 less than the maximum value set for this interface by the <b>atm vc-per-vp</b> command. Typically, lower values 0 to 31 are reserved for specific traffic (for example, F4 OAM, SVC signaling, ILMI, and so on) and should not be used.</p> <p>The VCI is a 16-bit field in the header of the ATM cell. The VCI value is unique only on a single link, not throughout the ATM network, because it has local significance only.</p> <p>The arguments <i>vpi</i> and <i>vci</i> cannot both be set to 0; if one is 0, the other cannot be 0.</p>
<b>ilmi</b>	(Optional) Used to set up communication with the ILMI; the associated <i>vpi</i> and <i>vci</i> values ordinarily are 0 and 16, respectively.
<b>qsaal</b>	(Optional) A signaling-type PVC used for setting up or tearing down SVCs; the associated <i>vpi</i> and <i>vci</i> values ordinarily are 0 and 5, respectively.
<b>smds</b>	(Optional) Encapsulation for SMDS networks. If you are configuring an ATM PVC on the ATM Interface Processor (AIP), you must configure AAL3/4SMDS using the <b>atm aal aal3/4</b> command before specifying <b>smds</b> encapsulation. If you are configuring an ATM network processor module (NPM), the <b>atm aal aal3/4</b> command is not required. SMDS encapsulation is not supported on the ATM port adapter.

### Defaults

No PVC is defined. When a PVC is defined, the global default of the **encapsulation** command applies (*aal-encap* = **aal5snap**).

### Command Modes

Interface or subinterface configuration

**Command History**

Release	Modification
11.3 T	This command was introduced.
12.1(5)XM	This command was extended to the merged SGCP/MGCP software.

**Usage Guidelines****Creating and Configuring PVCs**

The **pvc** command replaces the **atm pvc** command, which, although still supported and available, will become obsolete in the near future. Use the **pvc** command to configure a single ATM VC only, not a VC that is a bundle member. We recommend that you use the **pvc** command in conjunction with the **encapsulation** and **random-detect attach** commands instead of the **atm pvc** command.

The **pvc** command creates a PVC and attaches it to the VPI and VCI specified. Both the *vpi* and *vci* arguments cannot be simultaneously specified as 0; if one is 0, the other cannot be 0.

When configuring an SVC, use the **pvc** command to configure the PVC that handles SVC call setup and termination. In this case, specify the **qsaal** keyword. See the second example that follows.

**ATM PVC Names**

Once you specify a name for a PVC, you can reenter interface-ATM-VC configuration mode by simply entering the **pvc name** command. You can remove a PVC and any associated parameters by entering **no pvc name** or **no pvc vpi/vci**.

**Note**

After configuring the parameters for an ATM PVC, you must exit the interface-ATM-VC configuration mode in order to create the PVC and enable the settings.

**Encapsulation Types on ATM PVCs**

Specify ILMI, QSAAL, or SMDS as the encapsulation type on an ATM PVC. (To configure other encapsulations types, see the **encapsulation** command.)

**Rate Queues**

The Cisco IOS software dynamically creates rate queues as necessary to satisfy the requests of the **pvc** commands.

**Default Configurations**

If **ilmi**, **qsaal**, or **smds** encapsulation is not explicitly configured on the ATM PVC, the PVC inherits the following default configuration (listed in order of next highest precedence):

- Configuration of the **encapsulation** command in a VC class assigned to the PVC itself.
- Configuration of the **encapsulation** command in a VC class assigned to the ATM subinterface of the PVC.
- Configuration of the **encapsulation** command in a VC class assigned to the ATM main interface of the PVC.
- Global default: The global default of the **encapsulation** command applies (*aal-encap* = **aal5snap**).

**Examples**

The following example creates a PVC with VPI 0 and VCI 16, and communication is set up with the ILMI:

```
pvc cisco 0/16 ilmi
exit
```

The following example creates a PVC used for ATM signaling for an SVC. It specifies VPI 0 and VCI 5:

```
pvc cisco 0/5 qsaal
exit
```

The following example configures the PVC called cisco to use class-based weighted fair queuing (CBWFQ). It attaches a policy map called policy1 to the PVC. The classes comprising policy1 determine the service policy for the PVC:

```
pvc cisco 0/5
  service-policy output policy1
vbr-nrt 2000 2000
encap aal5snap
```

**Related Commands**

Command	Description
<b>atm vc-per-vp</b>	Sets the maximum number of VCIs to support per VPI.
<b>pvc-bundle</b>	Adds a PVC to a bundle as a member of the bundle and enters bundle-vc configuration mode in order to configure that PVC bundle member.

# show mgcp

To display MGCP configuration information, use the **show mgcp** EXEC command.

**show mgcp** [**connection** | **endpoint** | **statistics**]

Syntax Description	connection	(Optional) Displays the active MGCP-controlled connections.
	endpoint	(Optional) Displays the MGCP-controlled endpoints.
	statistics	(Optional) Displays MGCP statistics regarding received and transmitted network messages.

**Defaults** None

**Command Modes** EXEC

Command History	Release	Modification
	12.1(1)T	This command was introduced for the Cisco AS5300.
	12.1(3)T	Output was updated to show additional gateway and platform information.
	12.1(5)XM	Output was updated to show additional gateway and platform information.

**Examples** Following are examples of the command formats and outputs for: **show mgcp**, **show mgcp connection**, **show mgcp statistics**, and **show mgcp endpoint**.

```
Router# show mgcp
```

```
MGCP Admin State ACTIVE, Oper State ACTIVE - Cause Code NONE
MGCP call-agent: 172.29.248.51 Initial protocol service is MGCP, v. 0.1
MGCP block-newcalls DISABLED
MGCP send RSIP for SGCP is DISABLED
MGCP quarantine mode discard/step
MGCP quarantine of persistent events is ENABLED
MGCP dtmf-relay voip codec all mode cisco
MGCP dtmf-relay for VoAAL2 disabled for all codec types
MGCP voip modem passthrough mode: CISCO, codec: g711ulaw, redundancy: DISABLED,
MGCP voaal2 modem passthrough mode: NSE, codec: g711ulaw
MGCP TSE payload: 0
MGCP Network (IP/AAL2) Continuity Test timer: 200
MGCP 'RTP stream loss' timer disabled
MGCP request timeout 500, MGCP request retries 3
MGCP icmp unreachable timeout 5000
MGCP gateway port: 2427, MGCP maximum waiting delay 3000
MGCP restart delay 0, MGCP vad DISABLED
MGCP simple-sdp DISABLED
MGCP undotted-notation DISABLED
MGCP codec type g711ulaw, MGCP packetization period 20
MGCP JB threshold lwm 30, MGCP JB threshold hwm 150
```

```

MGCP LAT threshold lmw 150, MGCP LAT threshold hwm 300
MGCP PL threshold lwm 1000, MGCP PL threshold hwm 10000
MGCP CL threshold lwm 1000, MGCP CL threshold hwm 10000
MGCP playout mode is adaptive 60, 4, 200 in msec
MGCP IP ToS low delay disabled, MGCP IP ToS high throughput disabled
MGCP IP ToS high reliability disabled, MGCP IP ToS low cost disabled
MGCP IP RTP precedence 5, MGCP signaling precedence: 3
MGCP default package: line-package
MGCP supported packages: gm-package dtmf-package trunk-package line-package
                        hs-package rtp-package atm-package ms-package dt-package

```

**Table 1** *show mgcp Field Descriptions*

Field Name	Description
MGCP Admin State...Oper State	The administrative and operational state of the MGCP daemon. The administrative state controls starting and stopping the application using the <b>mgcp</b> and <b>mgcp block-newcalls</b> commands. The operational state controls normal MGCP operations.
MGCP call-agent	The address of the call agent specified in the <b>mgcp</b> command.
Initial protocol service is...	Indicates the protocol initiated for this session.
MGCP block-newcalls	The state of the <b>mgcp block-newcalls</b> command.
MGCP send RSIP for SGCP	The setting for the <b>mgcp sgcp restart notify</b> command.
MGCP quarantine mode	Indicates how the quarantine buffer is to handle SGCP events.
MGCP quarantine of persistent events	Indicates if SGCP persistent events will be handled by the quarantine buffer.
MGCP dtmf-relay	The setting for the <b>mgcp dtmf-relay</b> command.
MGCP voip modem passthrough	Indicates the settings for mode, codec, and redundancy from the commands <b>mgcp modem passthrough mode</b> , <b>mgcp modem passthrough codec</b> , and <b>mgcp modem passthrough voip redundancy</b> .
MGCP voaal2 modem passthrough	Indicates the settings for mode, codec, and redundancy from the commands <b>mgcp modem passthrough mode</b> and <b>mgcp modem passthrough codec</b> .
MGCP TSE payload	The setting for the <b>mgcp tse payload</b> command.
MGCP Network (IP/AAL2) Continuity Test timer	The setting for the <b>net-cont-test</b> option in the <b>mgcp timer command</b> .
MGCP 'RTP stream loss' timer	The setting for the <b>receive-rtcp</b> option in the <b>mgcp timer command</b> .
MGCP request timeout	The setting for the <b>mgcp request timeout</b> command.
MGCP request retries	The setting for the <b>mgcp request retries</b> command.
MGCP icmp unreachable timeout	The setting for the <b>mgcp rtp unreachable timeout</b> command.
MGCP gateway port	The UDP port specification.
MGCP maximum waiting delay	The setting for the <b>mgcp max-waiting-delay</b> command.
MGCP restart delay	The setting for the <b>mgcp restart-delay</b> command.
MGCP vad	The setting for the <b>mgcp vad</b> command.
MGCP sdp simple	Indicates whether the simple sdp protocol is being used.

Table 1 (continued) show mgcp Field Descriptions

Field Name	Description
MGCP undotted-notation	Indicates whether dotted or undotted notation is used for the codec string in SDP.
MGCP codec type	The setting for the <b>mgcp codec</b> command.
MGCP packetization period	The <b>packetization period</b> parameter setting for the <b>mgcp codec</b> command.
MGCP JB threshold lwm	The jitter buffer minimum threshold parameter setting for the <b>mgcp quality-threshold</b> command.
MGCP JB threshold hwm	The jitter buffer maximum threshold parameter setting for the <b>mgcp quality-threshold</b> command.
MGCP LAT threshold lwm	The latency minimum threshold parameter setting for the <b>mgcp quality-threshold</b> command.
MGCP LAT threshold hwm	The latency maximum threshold parameter setting for the <b>mgcp quality-threshold</b> command.
MGCP PL threshold lwm	The packet loss minimum threshold parameter setting for the <b>mgcp quality-threshold</b> command.
MGCP PL threshold hwm	The packet loss maximum threshold parameter setting for the <b>mgcp quality-threshold</b> command.
MGCP CL threshold lwm	The cell loss minimum threshold parameter setting for the <b>mgcp quality-threshold</b> command.
MGCP CL threshold hwm	The cell loss maximum threshold parameter setting for the <b>mgcp quality-threshold</b> command.
MGCP playout mode	The jitter buffer packet size type and size.
MGCP IP ToS low delay	The <b>low-delay</b> parameter setting for the <b>mgcp ip-tos</b> command.
MGCP IP ToS high throughput	The <b>high-throughput</b> parameter setting for the <b>mgcp ip-tos</b> command.
MGCP IP ToS high reliability	The <b>high-reliability</b> parameter setting for the <b>mgcp ip-tos</b> command.
MGCP IP ToS low cost	The <b>low-cost</b> parameter setting for the <b>mgcp ip-tos</b> command.
MGCP IP RTP precedence	The <b>rtp precedence</b> parameter setting for the <b>mgcp ip-tos</b> command.
MGCP signaling precedence	The <b>signaling precedence</b> parameter setting for the <b>mgcp ip-tos</b> command.
MGCP default package	The default-package parameter setting for the <b>mgcp default-package</b> command.
MGCP supported packages	The packages supported in this session.

The following example shows the output for VoIP connections:

Router# **show mgcp connection**

```
Endpoint  Call_ID(C) Conn_ID(I) (P)ort (M)ode (S)tate (C)odec (E)vent[SIFL] (R)esult[EA]
1. S0/DS1-0/1 C=103,23,24 I=0x8 P=16586,16634 M=3 S=4,4 C=5 E=2,0,0,2 R=0,0
2. S0/DS1-0/2 C=103,25,26 I=0x9 P=16634,16586 M=3 S=4,4 C=5 E=0,0,0,0 R=0,0
3. S0/DS1-0/3 C=101,15,16 I=0x4 P=16506,16544 M=3 S=4,4 C=5 E=2,0,0,2 R=0,0
4. S0/DS1-0/4 C=101,17,18 I=0x5 P=16544,16506 M=3 S=4,4 C=5 E=0,0,0,0 R=0,0
5. S0/DS1-0/5 C=102,19,20 I=0,6 P=16572,16600 M=3 S=4,4 C=5 E=2,0,0,2 R=0,0
6. S0/DS1-0/6 C=102,21,22 I=0x7 P=16600,16572 M=3 S=4,4 C=5 E=0,0,0,0 R=0,0
```

Total number of active calls 6

**Table 2** *show mgcp connection (VoIP) Field Descriptions*

Field Name	Description
Endpoint	The endpoint for each call shown in the digital endpoint naming convention of slot number (S0) and digital line (DS1-0) number (1).
Call_ID(C)	The MGCP call ID sent by the call agent, the internal Call Control Application Programming Interface (CCAPI) call ID for this endpoint, and the peer call legs CCAPI call ID.  (CCAPI is an API that provides call control facilities to applications.)
Conn_ID(I)	The connection ID generated by the gateway and sent in the ACK message.
(P)ort	The ports used for this connection. The first port is the local UDP port. The second port is the remote UDP port.
(M)ode	The call mode, where:  0—Indicates an invalid value for mode. 1—Indicates the gateway should only send packets. 2—Indicates the gateway should only receive packets. 3—Indicates the gateway can send and receive packets. 4—Indicates the gateway should neither send nor receive packets. 5—Indicates the gateway should place the circuit in loopback mode. 6—Indicates the gateway should place the circuit in test mode. 7—Indicates the gateway should use the circuit for network access for data. 8—Indicates the gateway should place the connection in network loopback mode. 9—Indicates the gateway should place the connection in network continuity test mode. 10—Indicates the gateway should place the connection in conference mode. All other values are used for internal debugging.
(S)tate	The call state. The values are used for internal debugging purposes.
(C)odec	The codec identifier. The values are used for internal debugging purposes.
(E)vent [SIFL]	Used for internal debugging.
(R)esult [EA]	Used for internal debugging.

The following example shows output for VoAAL2 connections:

```
Router# show mgcp connection
```

```
Endpoint      Call_ID(C) Conn_ID(I) (V)cci/cid (M)ode (S)tate (C)odec (E)vent[SIFL] (R)esult[EA]
1. aaln/S1/1  C=1,11,12  I=0x2    V=2/10    M=3      S=4,4     C=1      E=3,0,0,3  R=0,0
```

```
Total number of active calls 1
```

**Table 3** *show mgcp connection (VoAAL2) Field Descriptions*

Field Name	Description
Endpoint	The endpoint for each call shown in the digital endpoint naming convention of slot number (S0) and digital line (DS1-0) number (1).
Call_ID(C)	The MGCP call ID sent by the call agent, the internal Call Control Application Programming Interface (CCAPI) call ID for this endpoint, and the peer call legs CCAPI call ID.  (CCAPI is an API that provides call control facilities to applications.)
Conn_ID(I)	The connection ID generated by the gateway and sent in the ACK message.
Vcci/cid	The VCCI and CID used for the VoAAL2 call.
(M)ode	The call mode, where:  0—Indicates an invalid value for mode. 1—Indicates the gateway should only send packets. 2—Indicates the gateway should only receive packets. 3—Indicates the gateway can send and receive packets. 4—Indicates the gateway should neither send nor receive packets. 5—Indicates the gateway should place the circuit in loopback mode. 6—Indicates the gateway should place the circuit in test mode. 7—Indicates the gateway should use the circuit for network access for data. 8—Indicates the gateway should place the connection in network loopback mode. 9—Indicates the gateway should place the connection in network continuity test mode. 10—Indicates the gateway should place the connection in conference mode.  All other values are used for internal debugging.
(S)tate	The call state. The values are used for internal debugging purposes.
(C)odec	The codec identifier. The values are used for internal debugging purposes.
(E)vent [SIFL]	Used for internal debugging.
(R)esult [EA]	Used for internal debugging.

The following example shows output for VoIP and VoAAL2 statistics:

```
Router# show mgcp statistics

UDP pkts rx 8, tx 9
Unrecognized rx pkts 0, MGCP message parsing errors 0
Duplicate MGCP ack tx 0, Invalid versions count 0
CreateConn rx 4, successful 0, failed 0
DeleteConn rx 2, successful 2, failed 0
ModifyConn rx 4, successful 4, failed 0
DeleteConn tx 0, successful 0, failed 0
NotifyRequest rx 0, successful 4, failed 0
AuditConnection rx 0, successful 0, failed 0
AuditEndpoint rx 0, successful 0, failed 0
RestartInProgress tx 1, successful 1, failed 0
Notify tx 0, successful 0, failed 0
ACK tx 8, NACK tx 0
ACK rx 0, NACK rx 0
IP address based Call Agents statistics:
IP address 10.24.167.3, Total msg rx 8, successful 8, failed 0
```

**Table 4** *show mgcp statistics* Field Descriptions

Field Name	Description
UDP pkts rx, tx	The number of UDP packets transmitted and received by the gateway's MGCP application from the call agent.
Unrecognized rx pkts	The number of unrecognized UDP packets received by the MGCP application.
MGCP message parsing errors	The number of MGCP messages received with parsing errors.
Duplicate MGCP ack tx messages	The number of duplicate MGCP acknowledgment messages transmitted to the call agent(s).
Invalid versions count	The number of MGCP messages received with invalid MGCP protocols version.
CreateConn rx	The number of Create Connection (CRCX) messages received by the gateway, the number that were successful, and the number that failed.
DeleteConn rx	The number of Delete Connection (DLCX) messages received by the gateway, the number that were successful, and the number that failed.
NotifyRequest rx	The number of Notify Request (RQNT) messages received by the gateway, the number that were successful, and the number that failed.
AuditConnection rx	The number of Audit Connection (AUCX) message received by the gateway, the number that were successful, and the number that failed.
AuditEndpoint rx	The number of Audit Endpoint (AUEP) messages received by the gateway, the number that were successful, and the number that failed.
RestartinProgress tx	The number of Restart in Progress (RSIP) messages transmitted by the gateway, the number that were successful, and the number that failed.
Notify tx	The number of Notify (NTFY) messages transmitted by the gateway, the number that were successful, and the number that failed.
ACK tx, NACK tx	The number of Acknowledgment and Negative Acknowledgment messages transmitted by the gateway.

**Table 4** *show mgcp statistics Field Descriptions*

Field Name	Description
ACK rx, NACK rx	The number of Acknowledgment and Negative Acknowledgment messages received by the gateway.
IP address based Call Agents statistics: IP address, Total msg rx	IP address of the call agent, the total number of MGCP messages received from that call agent, the number of messages that were successful, and the number of messages that failed.

The following example shows how endpoints are configured:

```
Router# show mgcp endpoint
      ENDPOINT-NAME      V-PORT  SIG-TYPE  ADMIN
ds1-0/1@sblab116      0:1     fxs-gs    up
ds1-0/2@sblab116      0:1     fxs-gs    up
ds1-0/3@sblab116      0:1     fxs-gs    up
ds1-0/4@sblab116      0:1     fxs-gs    up
ds1-0/5@sblab116      0:1     fxs-gs    up
ds1-0/6@sblab116      0:1     fxs-gs    up
ds1-0/7@sblab116      0:1     fxs-gs    up
ds1-0/8@sblab116      0:1     fxs-gs    up
ds1-0/9@sblab116      0:1     fxs-gs    up
ds1-0/10@sblab116     0:1     fxs-gs    up
ds1-0/11@sblab116     0:1     fxs-gs    up
ds1-0/12@sblab116     0:1     fxs-gs    up
ds1-0/13@sblab116     0:1     fxs-gs    up
ds1-0/14@sblab116     0:1     fxs-gs    up
ds1-0/15@sblab116     0:1     fxs-gs    up
ds1-0/16@sblab116     0:1     fxs-gs    up
ds1-0/17@sblab116     0:1     fxs-gs    up
ds1-0/18@sblab116     0:1     fxs-gs    up
ds1-0/19@sblab116     0:1     fxs-gs    up
ds1-0/20@sblab116     0:1     fxs-gs    up
ds1-0/21@sblab116     0:1     fxs-gs    up
ds1-0/22@sblab116     0:1     fxs-gs    up
ds1-0/23@sblab116     0:1     fxs-gs    up
ds1-0/24@sblab116     0:1     fxs-gs    up
```

Interface T1 1

```
      ENDPOINT-NAME      V-PORT  SIG-TYPE  ADMIN
ds1-1/1@sblab116      1:1     e&m-imd   up
ds1-1/2@sblab116      1:1     e&m-imd   up
```

**Related Commands**

Command	Description
<a href="#">mgcp</a>	Starts the MGCP daemon.

## vbr-rt

To configure the real-time variable bit rate (VBR) for voice connections on the Cisco MC3810 series platform, use the **vbr-rt** in the appropriate command mode. To restore the default value, use the **no** form of this command.

**vbr-rt** *peak-rate average-rate burst*

**no vbr-rt**

### Syntax Description

<i>peak-rate</i>	The Peak Information Rate (PIR) of the voice connection in kbps. If it doesn't exceed your carrier's line rate, set it to the line rate. The range is from 56 to 10000.
<i>average-rate</i>	The Average Information Rate (AIR) of the voice connection in kbps.
<i>burst</i>	Burst size in number of cells. The range is from 0 to 65536.

### Defaults

No vbr-rt settings are configured.

### Command Modes

Interface-ATM-VC configuration (for an ATM PVC or SVC)  
 VC-class configuration (for a VC class)  
 Bundle-vc configuration (for ATM VC bundle members)

### Command History

Release	Modification
12.0	This command was introduced.
12.1(5)XM	Support for this command was extended to the merged SGCP/MGCP software.

### Usage Guidelines

This command applies to Voice over ATM on the Cisco MC3810 series platform.

The **vbr-rt** command configures traffic shaping between voice and data PVCs. Traffic shaping is required so that the carrier does not discard calls. To configure voice and data traffic shaping, you must configure the peak, average, and burst options for voice traffic. Configure the burst value if the PVC will be carrying bursty traffic. The peak, average, and burst values are needed so the PVC can effectively handle the bandwidth for the number of voice calls.

To calculate the minimum peak, average, and burst values for the number of voice calls, use the following calculations:

- Peak value:  $(2 \times \text{the maximum number of calls}) \times 16 \text{ kb}$
- Average value: Calculate according to the maximum number of calls the PVC will carry times the bandwidth per call. The following formulas give you the average rate in kbps:

**for VoIP:**

G.711 with 40 or 80 byte sample size:  $\text{max calls} \times 128\text{K}$

G.726 with 40 byte sample size: max calls x 85K

G.729a with 10 byte sample size: max calls x 85K

**for VoAAL2:**

G.711 with 40 byte sample size: max calls x 85K

G.726 with 40 byte sample size: max calls x 43K

G.729a with 10 byte sample size: max calls x 43K

If voice activity detection (VAD) is enabled, the bandwidth usage is reduced by as much as 12 percent with the maximum number of calls in progress. With fewer calls in progress, bandwidth savings are less.

- Burst value: Set the burst size as large as possible, and never less than the minimum burst size.

Guidelines are as follows:

The minimum burst size is 4 times the number of voice calls.

The maximum burst size is the maximum allowed by the carrier.



**Note**

When you configure data PVCs that will be traffic shaped with voice PVCs, use the aal5snap encapsulation and calculate the overhead as 1.13 times the voice rate.

**Examples**

The following example configures the traffic shaping rate for ATM PVC 20 on a Cisco MC3810 series platform. In the example, the peak, average and burst rates are calculated based on a maximum of 20 calls on the PVC.

```
pvc 20
 encapsulation aal5mux voice
 vbr-rt 640 320 80
```

**Related Commands**

Command	Description
<b>encapsulation aal5</b>	Configures the AAL and encapsulation type for an ATM PVC, SVC, or VC class.

# vcci

To identify a PVC to the call agent, use the **vcci** command in the ATM VC configuration mode. To restore the default value, use the **no** form of this command.

**vcci** *pvc-identifier*

**no vcci**

Syntax	Description
<i>pvc-identifier</i>	Set the identifier for the PVC. Valid values are 0 through 32767.

Defaults	Value
	none

Command Modes	Mode
	ATM virtual circuit configuration mode

Command History	Release	Modification
	12.1(5)XM	This command was introduced.

Usage Guidelines	Guidelines
	The <i>pvc-identifier</i> is a unique 15-bit value for each PVC. The call agent sets up a call with the gateway by specifying the PVC using the <i>pvc-identifier</i> .

Examples	Example
	The following example shows how to assign a PVC identifier:

```
Router(config-if-atm-vc)# vcci 5278
```

Related Commands	Command	Description
	<a href="#">mgcp</a>	Starts the MGCP daemon.
	<a href="#">pvc</a>	Creates an ATM PVC for voice traffic.

# Glossary

**AAL2**—ATM Adaptation Layer 2

**AAL5**—ATM Adaptation Layer 5

**BGW**—see business gateway

**business gateway**—An xGCP media gateway which is a business customer premises equipment that has connection(s) to the VoIP network as well as connection(s) to the user's telephony equipment (typically a PBX, a corporate LAN or WAN). Such gateways are used to eliminate or reduce the need for individual medium (voice, data, and so forth) connectivity.

**CA**—call agent

**call agent**—An intelligent entity in an IP telephony network which handles call control in an MGCP model Voice over IP network.

**CAS**—Channel Associated Signaling

**CCS**—Common Channel Signaling

**CID**—AAL2 Channel Identifier

**CLASS**—Custom Local Area Subscriber Services, usually referred to as “Custom Calling” features

**DS-0**—64 kbps channel in a T1/E1 line

**DTMF**—Dual Tone Multi-frequency

**E&M**—Ear and Mouth analog signaling

**FXO**—Foreign Exchange Operator—An interface from a telephone to a PSTN central office or a station interface on a PBX.

**FXS**—Foreign Exchange Station—An interface that connects to a telephone, key set, or PBX to supply ring, voltage, and dial tone.

**media gateway**—Equipment that connects the PSTN or a PBX with the VoIP network. It is controlled by a call agent via MGCP.

**MGC**—media gateway controller. Another name for call agent.

**MGCP**—Media Gateway Control Protocol

**NAS**—Network Access Server

**package**—A set of signals and events that define a type of voice endpoint or connection. Examples include line-package, trunk-package, dtmf-package, and atm-package. See the [mgcp default-package](#) and [mgcp package-capability](#) commands for information on configuring package use.

**PRI**—ISDN primary rate interface

**PSTN**—Public Switched Telephone Network

**PVC**—Permanent Virtual Circuit

**residential gateway**—An xGCP media gateway which is customer premises equipment that has connection(s) to the VoIP network as well as connection(s) to user's telephony equipment.

**RGW**—see residential gateway

**RTCP**—RTP Control Protocol. The protocol monitors an RTP connection and conveys information about the on-going session.

**RTP**—Real-Time Transport Protocol. The protocol provides end-to-end network transport functions for applications transmitting real-time data and services such as payload type identification, sequence numbering, timestamping, and delivery monitoring.

**SGCP**—Simple Gateway Control Protocol

**SPVC**—Soft Permanent Virtual Circuit

**SVC**—Switched Virtual Circuit

**TGW**—see trunking gateway

**trunking gateway**—An xGCP media gateway that provides connectivity between the PSTN and VoIP networks.

**TSE**—Inband Telephony Signaling Events

**VAD**—Voice Activity Detection

**VCC**—Virtual Channel Connection (used where it may be a PVC, SPVC, or SVC)

**VoIP**—Voice over IP

**VToA**—Voice Trunking on ATM

