

# Configuring SNA Frame Relay Access Support

---

This chapter describes Frame Relay Access Support (FRAS) for Systems Network Architecture (SNA) devices. It also explains how to configure FRAS and how to use a FRAS host to connect Cisco Frame Relay Access Devices (FRADs) to channel-attached mainframes, LAN-attached FEPs, and LAN-attached AS/400s through a Cisco router.

For a complete description of the FRAS commands in this chapter, refer to the “SNA Frame Relay Access Support Commands” chapter of the *Bridging and IBM Networking Command Reference*. To locate documentation of specific commands, use the command reference master index or search online.

## SNA FRAS Configuration Task List

To configure FRAS, perform the tasks described in the following sections:

- Configure FRAS BNN Statically
- Configure FRAS BNN Dynamically
- Configure FRAS Boundary Access Node Support
- Configure SRB over Frame Relay
- Configure FRAS Congestion Management
- Configure FRAS DLCI Backup
- Configure Frame Relay RSRB Dial Backup
- Configure Frame Relay DLsw+ Dial Backup
- Monitor and Maintain FRAS

To configure the FRAS host, see the section “Configure FRAS Host.” For configuration examples, see the section “FRAS and FRAS Host Configuration Examples” at the end of this chapter.

## Configure FRAS BNN Statically

To configure FRAS (boundary network node) BNN statically, use one of the following commands in interface configuration mode:

Command	Purpose
<b>fras map llc</b> <i>mac-address lan-lsap lan-rsap serial port</i> <b>frame-relay dlci</b> <i>fr-lsap fr-rsap [pfid2   afid2   fid4]</i>	Associate an LLC connection with a Frame Relay DLCI.
<b>fras map sdlc</b> <i>sdlc-address serial port frame-relay dlci</i> <i>fr-lsap fr-rsap [pfid2   afid2   fid4]</i>	Associate an SDLC link with a Frame Relay DLCI.

In this implementation, you configure and define each end station MAC and SAP address pair statically.

Because Frame Relay itself does not provide a reliable transport as required by SNA, the RFC 1490 support of SNA uses LLC2 as part of the encapsulation to provide link-level sequencing, acknowledgment, and flow control. The serial interface configured for Internet Engineering Task Force (IETF) encapsulation (that is, RFC 1490) accepts all LLC2 interface configuration commands.

## Configure FRAS BNN Dynamically

To configure FRAS BNN dynamically, use one of the following commands in interface configuration mode:

Command	Purpose
<b>fras map llc</b> <i>lan-lsap serial interface frame-relay dlci dlci</i> <i>fr-rsap</i>	Associate an LLC connection with a Frame Relay DLCI.
<b>fras map sdlc</b> <i>sdlc-address serial port frame-relay dlci</i> <i>fr-lsap fr-rsap [pfid2   afid2   fid4]</i>	Associate an SDLC link with a Frame Relay DLCI.

When you associate an LLC connection with a Frame Relay DLCI, the router “learns” the MAC/SAP information as it forwards packets to the host. The FRAS BNN feature provides seamless processing at the router regardless of end station changes. End stations can be added or deleted without reconfiguring the router.

When you associate an SDLC link with a Frame Relay DLCI, you configure and define each end station MAC and SAP address pair statically.

Because Frame Relay itself does not provide a reliable transport as required by SNA, the RFC 1490 support of SNA uses LLC2 as part of the encapsulation to provide link-level sequencing, acknowledgment, and flow control. The serial interface configured for Internet Engineering Task Force (IETF) encapsulation (that is, RFC 1490) can take all LLC2 interface configuration commands.

## Configure FRAS Boundary Access Node Support

To configure Frame Relay boundary access node (BAN), use the following command in interface configuration mode:

Command	Purpose
<b>fras ban</b> <i>local-ring bridge-number ring-group</i> <i>ban-dlci-mac dlci dlci#1 [dlci#2 . . . dlci#5] [bni mac-addr]</i>	Associate a bridge to the Frame Relay BAN.

BAN simplifies router configuration when multiple LLC sessions are multiplexed over the same DLCI. By comparison, SAP multiplexing requires static definitions and maintenance overhead. By using BAN, the Token Ring MAC address is included in every frame to uniquely identify the LLC session. Downstream devices can be dynamically added and deleted with no configuration changes required on the router.

## Configure SRB over Frame Relay

To configure SRB over Frame Relay, use the following commands in interface configuration mode:

Step	Command	Purpose
1	<b>interface serial</b> <i>number</i>	Specify the serial port.
2	encapsulation frame-relay	Enable Frame Relay encapsulation.
3	<b>interface serial</b> <i>slot/port.subinterface-number</i> <b>point-to-point</b>	Configure a Frame Relay point-to-point subinterface.
4	<b>frame-relay interface-dlci</b> <i>dlci ietf</i>	Configure a DLCI number for the point-to-point subinterface.
5	<b>source-bridge</b> <i>source-ring-number bridge-number</i> <i>target-ring-number</i> <b>conserve-ring</b>	Assign a ring number to the Frame Relay permanent virtual circuit.

Cisco IOS software offers the ability to encapsulate source-route bridging traffic using RFC 1490 Bridged 802.5 encapsulation. This provides SRB over Frame Relay functionality. This SRB over Frame Relay feature is interoperable with other vendors' implementations of SRB over Frame Relay and with some vendors' implementations of FRAS BAN.

SRB over Frame Relay does not support the following Cisco IOS software functions:

- Proxy explorer
- Automatic spanning tree
- LAN Network Manager

## Configure FRAS Congestion Management

FRAS provides a congestion control mechanism based on the interaction between congestion notification bits in the Frame Relay packet and the dynamic adjustment of the LLC2 send window. This window shows the number of frames the Cisco IOS software can send before waiting for an acknowledgment. The window size decreases with the occurrence of backward explicit congestion notification (BECN) and increases when no BECN frames are received.

To configure congestion management, use the following commands in interface configuration mode:

Step	Command	Purpose
1	<b>llc2 local-window</b> <i>packet-count</i>	Specify the maximum window size for each logical connection.
2	<b>llc2 dynwind</b> [ <i>nw nw-number</i> ] [ <i>dwc dwc-number</i> ]	Enable the dynamic window flow-control mechanism.

You can enable the dynamic window mechanism only if you are using Frame Relay IETF encapsulation.

## Configure FRAS DLCI Backup

To configure FRAS DLCI backup, use the following command in interface configuration mode:

Command	Purpose
<b>fras ddr-backup interface</b> <i>interface dlc-number</i>	Specify an interface to be used for the backup connection and indicate the DLCI number of the session.

FRAS DLCI backup is an enhancement to Cisco’s FRAS implementation that lets you configure a secondary path to the host to be used when the Frame Relay network becomes unavailable. When the primary Frame Relay link to the Frame Relay WAN fails, the FRAS DLCI backup feature causes the router to reroute all sessions from the main Frame Relay interface to the secondary interface. The secondary interface can be either serial or ISDN and must have a data link connection identifier (DLCI) configured.

Figure 135 illustrates Frame Relay backup over an ISDN connection.

**Figure 135 FRAS DLCI Backup over ISDN**

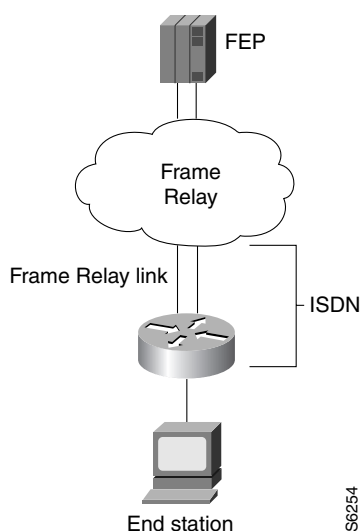

---

**Note** This feature provides backup for the local end of the Frame Relay connection, not the complete end-to-end connection.

---

## Configure Frame Relay RSRB Dial Backup

When the Frame Relay network is down, the Cisco IOS software checks whether the dial backup feature is configured for the particular DLCI number. If it is configured, the software removes the FRAS to the downstream device connection and establishes the RSRB to this downstream device connection.

To configure RSRB dial backup, use the following command in interface configuration mode:

Command	Purpose
<b>fras backup rsrb</b> <i>vmacaddr local-ring-number target-ring-number host-mac-address</i>	Activate Frame Relay RSRB dial backup.

## Configure Frame Relay DLSw+ Dial Backup

The FRAS dial backup over DLSw+ feature provides a secondary path that is used when the Frame Relay network becomes unavailable. If preconfigured properly, when the primary link to the Frame Relay WAN fails, FRAS dial backup over DLSw+ feature moves existing sessions to the alternate link automatically. When the primary link is restored, existing sessions are kept on the backup connection so they can be moved non-disruptively to the primary link at the user's discretion.

To enable FRAS dial backup over DLSw+, use the following command in interface configuration mode:

Command	Purpose
<b>fras backup dlsw</b> <i>virtual-mac-address target-ring-number host-mac-address</i> [retry number]	Configure an auxiliary (backup) route between the end stations and the host for use when the DLCI connection to the Frame Relay network is lost.

Figure 136 shows a Frame Relay network with FRAS dial backup over DLSw+.

Figure 136 FRAS Dial Backup over DLSw+

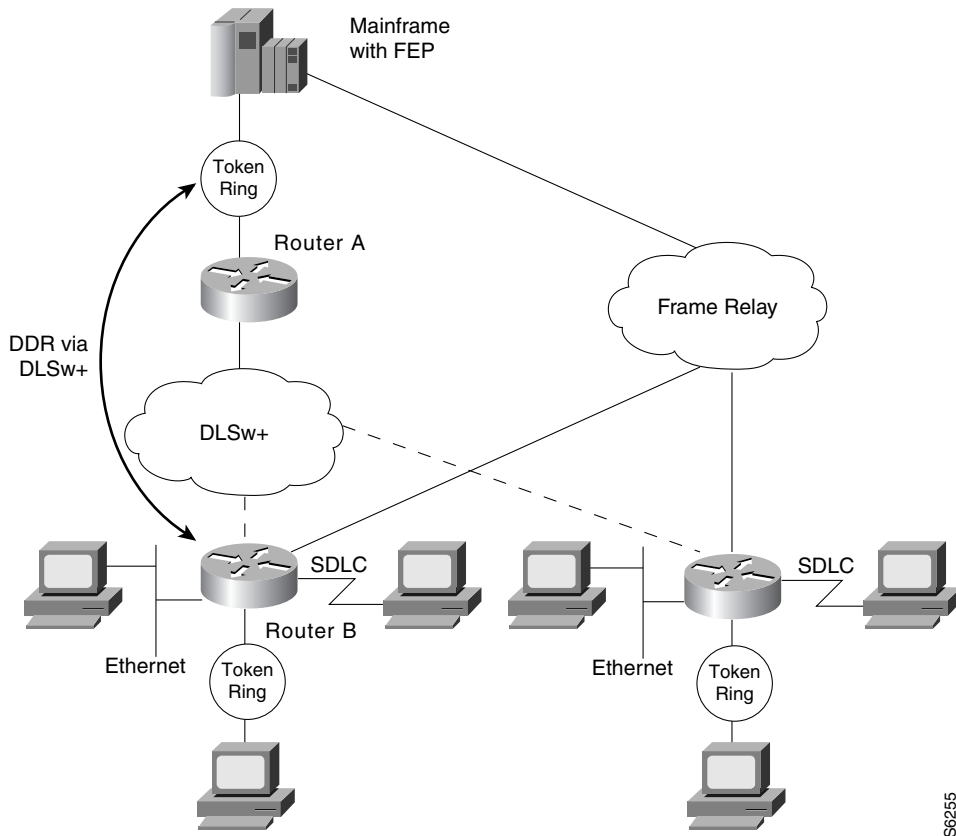

S66255



## Configure FRAS Host

The FRAS Host provides a scalable and efficient solution for SNA FRAD access to channel-attached hosts and to LAN-attached hosts. The FRAS Host function operates in two modes, which are documented in the following sections:

- **FRAS Host LLC2 Passthru**—In this mode, the LLC2 sessions are not locally terminated in the router's LLC2 stack. This is the recommended solution if your scenario includes a Channel Interface Processor (CIP) interface to the mainframe.
- **FRAS Host LLC2 Local Termination**—In this mode, the LLC2 sessions are locally terminated in the router's LLC2 stack. This is the recommended solution if either of the following is true:
  - Your scenario includes a LAN-attached AS/400 or mainframe
  - Your scenario includes conversion from RFC1490 encapsulation to DLSw+ encapsulation

### FRAS Host LLC2 Passthru

The FRAS Host LLC passthru feature combines with a CIP-attached Cisco router's high-speed channel access to provide FEP-class performance at a fraction of what it would cost to achieve similar functionality using a FEP. If the CIP SNA feature is used to interface with the mainframe, then FRAS Host LLC2 passthru mode is the recommended solution. In this topology the LLC2 passthru solution to the CIP-SNA LLC2 stack provides better performance, is more robust, and responds well to different types of congestion.

To prevent LLC2 session timeout, LLC2 characteristics (windows and timers) may be tuned on the CIP internal LAN adapter. The CIP/SNA LLC2 stack reacts to congestion by dynamically adjusting its LLC2 transmit window for that LLC2 session in response to dropped frames.

With the FRAS Host LLC passthru feature, you gain performance benefits of a channel attachment without FEP upgrades such as the addition of a Frame Relay interface, an upgrade to NCP (with its associated increase in monthly charges), and a possible increase in system memory.

Figure 138 illustrates Cisco FRAD access to a mainframe through a channel-attached Cisco router.

**Figure 138 Cisco FRAD Access to a Mainframe through a Cisco 7500**

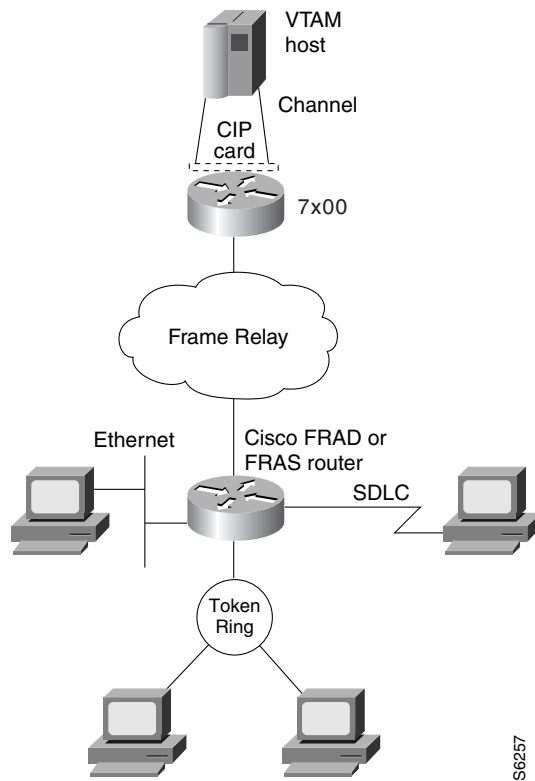

## FRAS Host LLC2 Local Termination

If the FRAS Host feature is used to allow remote FRADs to communicate with a LAN-attached IBM 3745 or AS/400, then LLC2 termination via DLSw+ local switching is the recommended solution. With this approach, the LLC2 sessions are terminated at the Route Processor. To prevent LLC2 session timeout, LLC2 characteristics (windows and timers) may be tuned on the virtual Token Ring interface. If the dynamic window algorithm is enabled on the virtual Token Ring interface, LLC2 local termination will react to congestion by dynamically adjusting its LLC2 transmit window in response to occurrence of Frame Relay BECN.

When you use the FRAS Host LLC2 local termination feature on a Token Ring-attached FEP, the FRAS Host Cisco router shields the FEP from having to manage the interface to the Frame Relay network. This avoids interface, memory, and NCP upgrades. The FRAS Host Cisco router simply provides LLC2 sessions to the FEP over the LAN.

If used in an environment with AS/400s, FRAS Host LLC2 local termination provides an even more valuable function. The Cisco FRAS Host router offloads the management of the Frame Relay connections from the AS/400. This reduces AS/400 system hardware requirements and frees AS/400 CPU cycles for user applications.

Figure 139 illustrates Cisco FRAD access to a LAN-attached SNA host through a Cisco router.

**Figure 139 Cisco FRAD Access to a LAN-Attached AS/400 through a Cisco 4500**

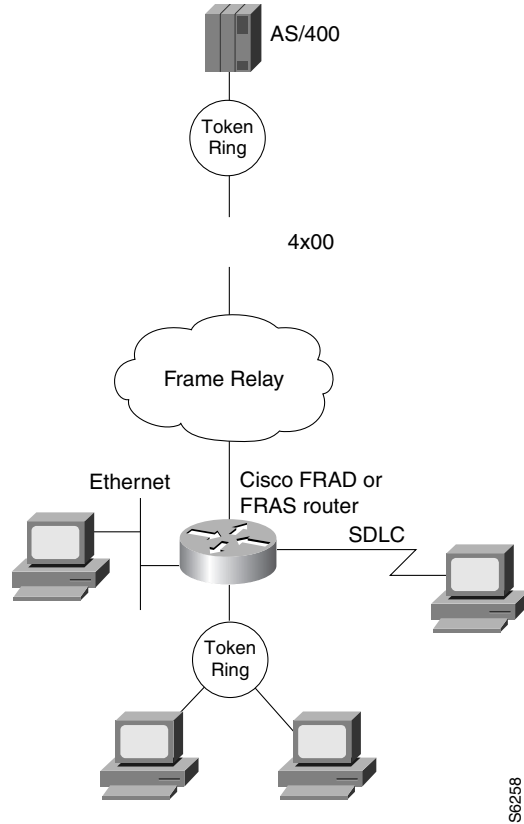

## Congestion Management

Both passthru and local acknowledgment environments support frame discard eligibility (DE) for additional congestion management. In both environments, you can further tune the interface to the Frame Relay network by taking advantage of the Cisco IOS Frame Relay features. Taken together, these features increase overall throughput dramatically by comparison to generic FRADs, which typically cannot use the network with the same degree of efficiency.

## FRAS Host Configuration Task List

To configure the FRAS Host migration feature, perform the tasks in the following sections:

- Create a Virtual Token Ring Interface
- Configure Source-Route Bridging on the Virtual Token Ring Interface
- Accept Default LLC2 Passthru or Enable LLC2 Local Termination
- Enable the FRAS Host Feature for BAN or BNN
- Monitor LLC2 Sessions Using FRAS Host

### Create a Virtual Token Ring Interface

To configure a virtual Token Ring interface, use the following command in interface configuration mode:

Command	Purpose
<b>interface virtual-tokenring</b> <i>number</i>	Configure a virtual Token Ring interface.

### Configure Source-Route Bridging on the Virtual Token Ring Interface

To configure SRB on the Token Ring interface, use the following commands, beginning in global configuration mode:

Step	Command	Purpose
1	<b>source-bridge ring-group</b> <i>ring-group</i> <i>virtual-mac-address</i>	Enable local source-route bridging.
2	<b>source-bridge</b> <i>local-ring</i> <i>bridge-number</i> <i>target-ring</i>	Enable FRAS Host traffic to access the SRB domain.

**Note** If you are using LLC2 passthru with an Ethernet-attached host, you must configure the Cisco source-route translational bridging (SR/TLB) feature.

### Accept Default LLC2 Passthru or Enable LLC2 Local Termination

LLC2 passthru is the default operational mode for all FRAS Host connections that use a virtual Token Ring interface. You do not need to perform any configuration to accept the default LLC2 passthru mode.

To enable LLC2 local termination for FRAS Host connections using the virtual Token Ring, use the following commands, beginning in global configuration mode:

Step	Command	Purpose
1	<b>dls</b> <b>local-peer</b>	Enable data link local switching.
2	<b>fras-host dls</b> <b>local-ack</b>	Enable LLC2 local termination for FRAS Host connections.

### Enable the FRAS Host Feature for BAN or BNN

To enable the FRAS Host for BAN or BNN, use the following commands in interface configuration mode:

Step	Command	Purpose
1	<b>fras-host bnn</b> ( <i>sub</i> ) <i>interface fr-lsap sap vmac virt-mac hmac hmac</i> [ <b>hsap hsap</b> ]	Configure the FRAS host for BNN.
2	<b>fras-host ban</b> ( <i>sub</i> ) <i>interface hmac hmac</i> [ <b>bni bni-mac</b> ]	Configure the FRAS host for BAN.

### Monitor LLC2 Sessions Using FRAS Host

To display the status of LLC2 sessions using FRAS Host, use the following command in privileged EXEC mode:

Command	Purpose
<b>show fras-host</b> [( <i>sub</i> ) <i>interface</i> ] [ <b>dldci dldci-num</b> ] [ <b>detail</b> ]	Display the status of LLC2 sessions using FRAS Host.

## FRAS and FRAS Host Configuration Examples

The following sections provide both FRAS and FRAS Host configuration examples:

- LAN-Attached SNA Devices Example
- SDLC-Attached SNA Devices Example
- FRAS BNN Topology Example
- FRAS BNN Example
- FRAS BAN Example
- SRB over Frame Relay Example
- FRAS DLCI Backup over Serial Interface Example
- FRAS Dial Backup over DLSw+ Example
- Cisco FRAD or FRAS Router Configuration Examples
- FRAS Host CIP Connection to VTAM Configuration Example
- FRAS Host Ethernet Connection to AS/400 Configuration Example

## LAN-Attached SNA Devices Example

Figure 140 illustrates the configuration of SNA devices attached to a LAN.

**Figure 140 LAN-Attached SNA Devices**

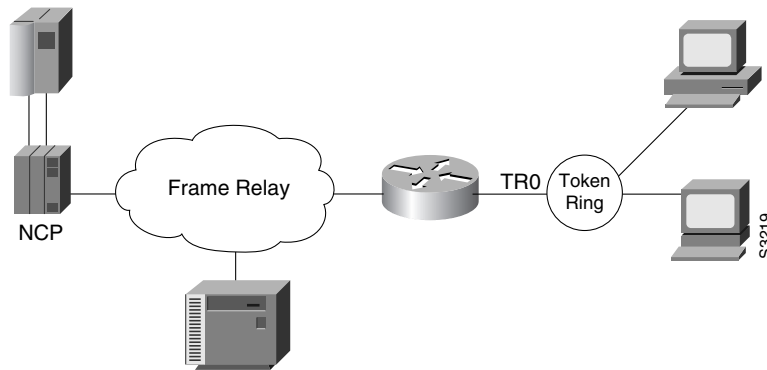

The configuration for the network shown in Figure 140 is as follows:

```
interface tokenring 0
  no ip address
  no keepalive
  ring-speed 16
  frans map llc 0800.5a8f.8802 4 4 serial 0 frame-relay 200 4 4
!
interface serial 0
  mtu 2500
  no ip address
  encapsulation frame-relay IETF
  keepalive 12
  frame-relay lmi-type ansi
  frame-relay map llc2 200
```

## SDLC-Attached SNA Devices Example

Figure 141 illustrates the configuration of SDLC-attached SNA devices.

**Figure 141 SDLC-Attached SNA Devices**

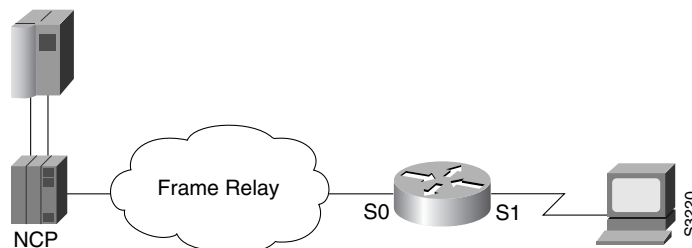

The configuration file for the network shown in Figure 141 is as follows:

```
interface serial 1
  no ip address
  encapsulation sdlc
  no keepalive
  clockrate 56000
  sdlc address C1
  sdlc xid C1 05D01501
  sdlc role primary
  frs map sdlc C1 serial 0 frame-relay 200 4 4
  !
interface serial 0
  mtu 2500
  no ip address
  encapsulation frame-relay ietf
  keepalive 12
  frame-relay lmi-type ansi
  frame-relay map llc2 200
```

### FRAS BNN Topology Example

FRAS BNN transports SNA traffic across different media through a Cisco router and then through a Frame Relay link to the host. SNA PU 2.0 and PU 2.1 devices may be attached to the remote router through Token Ring, SDLC, or Ethernet to access the Frame Relay network. The FRAS BNN topology is illustrated in Figure 142.

Figure 142 FRAS BNN Topology

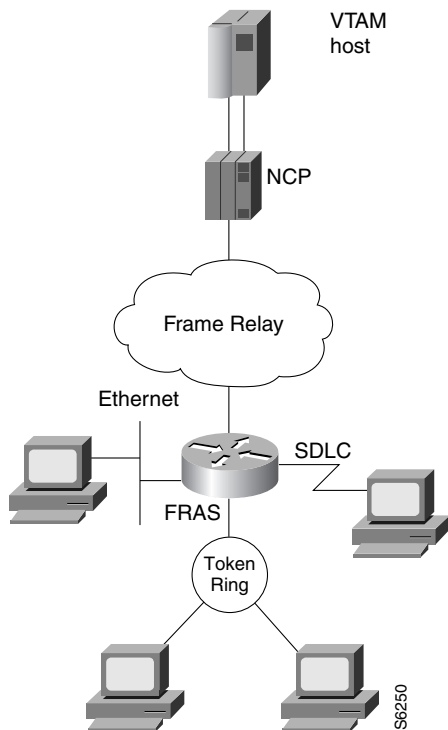

The original Frame Relay BNN feature transports traffic from multiple PUs over a single DLCI. This function is called SAP multiplexing. The router uses a unique SAP address (fr-lsap) for each downstream PU when communicating with the host. In this implementation, each end station's MAC/SAP address pair must be statically defined to the router. Consequently, the router must be re-configured each time an end station is moved, added, or deleted. The configuration overhead for this implementation can be high.

The FRAS BNN feature, where the router "learns" the MAC/SAP information as it forwards packets to the host, offers several advantages over the original FRAS BNN implementation. The BNN enhancement alleviates the need to reconfigure the router when end stations are moved, added, or deleted. The configuration is simple: one map definition in the router is sufficient for multiple downstream devices. The router "learns" the addresses of the downstream devices in the normal course of communication (as shown in Figure 143).

Figure 143 illustrates the Frame Relay BNN configuration for both the original implementation and the enhanced implementation.

**Figure 143 Frame Relay BNN Support**

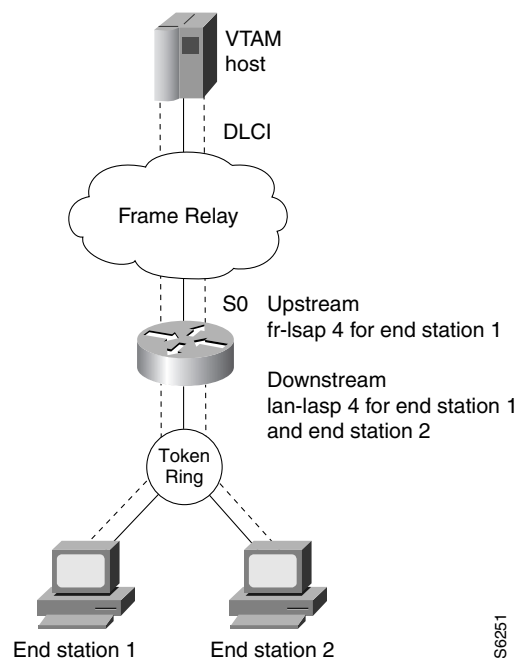

If the end station initiates the LLC session, the router acquires the Token Ring address and the SAP value of the end station from the incoming frame. Instead of mapping the end station's MAC/SAP address pair (as was done in the original FRAS BNN implementation), the destination MAC/SAP address pair of the incoming frame is mapped to the Frame Relay DLCI. If the destination SAP specified by the end station is equal to the lan-lsap address, the router associates the LLC (LAN) connection with the Frame Relay DLCI. The MAC address and the SAP address of the end station are no longer required in the router configuration. Thus, in the enhanced FRAS BNN implementation one configuration command achieves the same result for the end stations as did multiple configuration commands in the original FRAS BNN implementation.

**Note** The new FRAS BNN feature, which provides seamless processing at the router regardless of end-station changes, is designed to coexist with the original FRAS BNN feature. In Cisco IOS Release 11.2, only LLC2 traffic will be supported. SDLC must be configured using the original BNN implementation

## FRAS BNN Example

The following configuration example enables the FRAS BNN feature. The topology is illustrated in Figure 144.

**Figure 144 FRAS BNN Configuration**

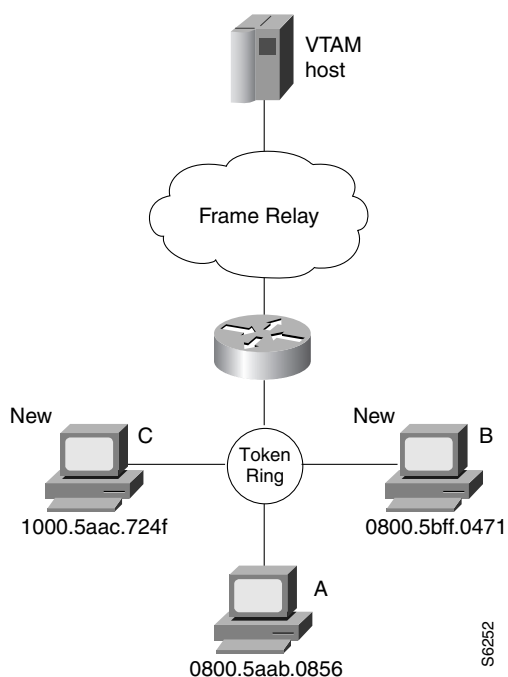

```

interface Serial0
  no ip address
  encapsulation frame-relay IETF
  frame-relay lmi-type ansi
  frame-relay map llc2 16
!
interface TokenRing0
  no ip address
  ring-speed 16
  fras map llc 0800.5aab.0856 04 04 Serial 0 frame-relay 16 04 04
  fras map llc 04 Serial 0 frame-relay dlci 16 04
  
```

**Note** In this configuration example, the second to last line describes the old configuration for workstation A. The last line describes the configuration for the new workstations B and C.

## FRAS BAN Example

The following configuration shows FRAS BAN support for Token Ring and serial interfaces. You must specify the **source-bridge ring-group** global command before you configure the **fras ban** interface command. When Token Ring is configured, the **source-bridge** interface command includes the *local-ring*, *bridge-number*, and the *target-ring* values. The **source-bridge** command enables local source-route bridging on a Token Ring interface.

```

source-bridge ring-group 200
!
interface serial 0
  mtu 4000
  encapsulation frame-relay ietf
  frame-relay lmi-type ansi
  frame-relay map llc2 16
  frame-relay map llc2 17
  fras ban 120 1 200 4000.1000.2000 dlci 16 17
!
interface tokenring 0
  source-bridge 100 5 200

```

For SDLC connections, you must include SDLC configuration commands as follows:

```

!
interface Serial1
  description SDLC line PU2.0
  mtu 265
  no ip address
  encapsulation sdlc
  no keepalive
  clockrate 9600
  sdlc role primary
  sdlc vmac 4000.0000.0000
  sdlc address C2
  sdlc xid C2 05D01502
  sdlc partner 4000.0000.2345 C2
  sdlc address C8
  sdlc xid C8 05D01508
  sdlc partner 4000.0000.2345 C8
  sdlc address C9
  sdlc xid C9 05D01509
  sdlc partner 4000.0000.2345 C9
  fras ban frame-relay Serial10 4000.0000.2345 dlci 16
!
interface Serial2
  description SDLC line PU2.1
  no ip address
  encapsulation sdlc
  no keepalive
  clockrate 19200
  sdlc role prim-xid-poll
  sdlc vmac 2000.0000.0000
  sdlc address C6
  sdlc partner 1000.2000.3000 C6
  fras ban frame-relay serial10 1000.2000.3000 dlci 16

```

## SRB over Frame Relay Example

Figure 145 illustrates the interoperability provided by SRB over Frame Relay. FRADs B and C forward frames from their locally attached Token Rings over the Frame Relay network using SRB.

**Figure 145 FRAD Using SRB over Frame Relay to Connect to a Cisco Router**

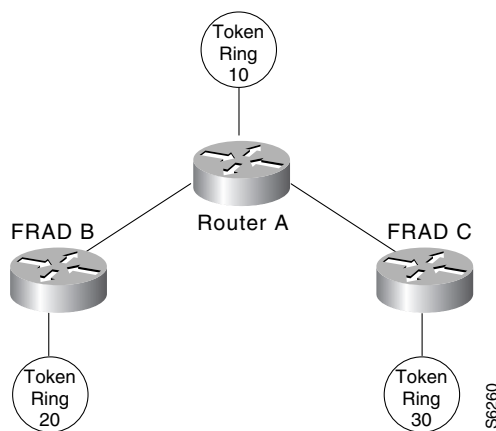

Figure 145 illustrates a network with the following characteristics:

- Virtual ring number of Router A = 100
- Virtual ring number of FRAD B = 200
- Virtual ring number of FRAD C = 300
- DLCI number for the partner's virtual ring (PVC) between Router A and FRAD B = 30
- DLCI number for PVC between Router A and FRAD C = 31

In this example we configure a new option, **conserve-ring**, on the **source-bridge** interface configuration command. When this option is configured, the SRB software does not add the ring number associated with the Frame Relay PVC to outbound explorer frames. This option is permitted for Frame Relay subinterfaces only.

The router configures the partner FRAD's virtual ring number as the ring number for the PVC.

This approach does not require a separate ring number per DLCI. The router configures the partner FRAD's virtual ring number as the ring number for the PVC.

FRAD B configures its virtual ring as 200 and the ring for the PVC as 100. FRAD C configures its virtual ring as 300 and the ring for the PVC as 100.

## FRAS DLCI Backup over Serial Interface Example

The following example shows a configuration for FRAS DLCI backup over a serial interface:

```

interface serial0
  mtu 3000
  no ip address
  encapsulation frame-relay IETF
  bandwidth 56
  keepalive 11
  frame-relay map llc2 277
  frame-relay map llc2 278
  frame-relay lmi-type ansi
  fras ddr-backup interface serial1 188
!
interface serial1
  mtu 3000
  no ip address
  encapsulation frame-relay IETF
  no cdp enable
  frame-relay map llc2 188
  frame-relay lmi-type ansi
!
interface serial2
  no ip address
  encapsulation sdlc
  no keepalive
  clock rate 19200
  sdlc role prim-xid-poll
  sdlc address D6
  fras map sdlc D6 s0 frame-relay 277 8 4
!
interface tokenring0
  no ip address
  ring-speed 16
  fras map llc 0000.f63a.2f70 4 4 serial0 frame-relay 277 4 4

```

### Router A

```

source-bridge ring-group 100
!
interface Serial1
  encapsulation frame-relay
!
interface Serial1.1 point-to-point
  frame-relay interface-dlci 30 ietf
  source-bridge 200 1 100 conserve-ring
  source-bridge spanning
!
interface Serial1.2 point-to-point
  frame-relay interface-dlci 31 ietf
  source-bridge 300 1 100 conserve-ring
  source-bridge spanning
!
interface TokenRing0
  source-bridge 500 1 100

```

## FRAS Dial Backup over DLSw+ Example

The following examples show configurations for FRAS dial backup over DLSw+:

### FRAS Dial Backup on a Subinterface

```
source-bridge ring-group 200
dlsw local-peer peer-id 10.8.8.8
dlsw remote-peer 0 tcp 10.8.8.7 dynamic
interface ethernet0
 ip address 10.8.8.8 255.255.255.0
!
interface serial0
 no ip address
 encapsulation frame-relay IETF
 frame-relay lmi-type ansi
!
interface Serial0.1 point-to-point
 description fras backup dlsw+ listening on dlci 16 configuration example
 no ip address
 frame-relay interface-dlci 16
 fras backup dlsw 4000.1000.2000 200 1000.5aed.1f53
!
interface TokenRing0
 no ip address
 ring-speed 16
 fras map llc 0000.f63a.2f50 4 4 Serial0.1 frame-relay 16 4 4
```

### FRAS Dial Backup on a Main Interface

```
source-bridge ring-group 200
dlsw local-peer peer-id 10.8.8.8
dlsw remote-peer 0 tcp 10.8.8.7 dynamic
interface ethernet0
 ip address 10.8.8.8 255.255.255.0
!
interface serial0
 no ip address
 encapsulation frame-relay IETF
 frame-relay lmi-type ansi
 frame-relay map llc2 16
 fras backup dlsw 4000.1000.2000 200 1000.5aed.1f53
!
interface Serial1
 ip address 10.8.8.8
!
interface tokening0
 no ip address
 ring-speed 16
 fras map llc 0000.f63a.2f50 4 4 Serial0 frame-relay 16 4 4
```

## Cisco FRAD or FRAS Router Configuration Examples

This section provides the following configuration examples ( see Figure 146)

- Cisco FRAD or FRAS Router A with BNN Configuration Example
- Cisco FRAD or FRAS Router B with BAN Configuration Example
- Cisco FRAD or FRAS Router C with BAN Configuration Example

**Figure 146 FRAS Host CIP Connection to VTAM**

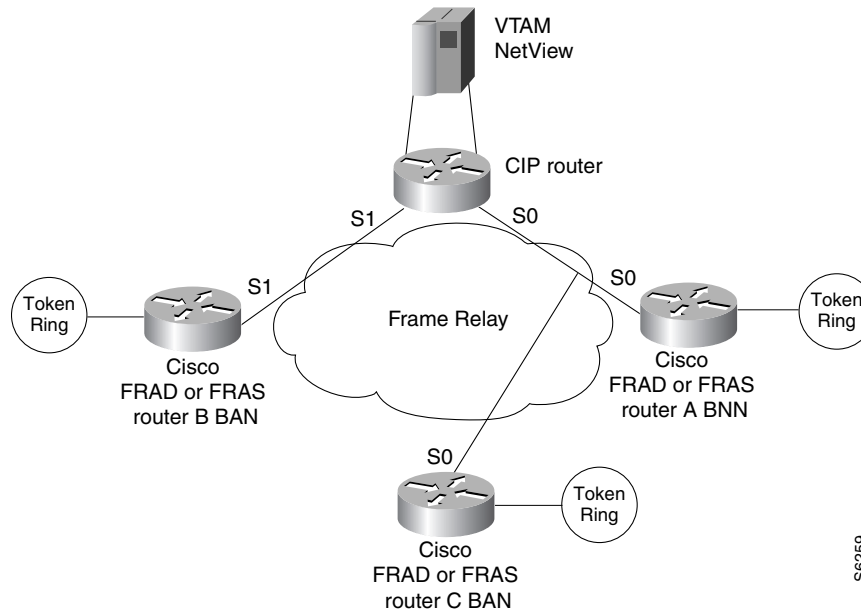

### Cisco FRAD or FRAS Router A with BNN Configuration Example

```
interface Serial0
 encapsulation frame-relay IETF
 frame-relay map llc2 16
!
interface TokenRing0
 fras map llc 4001.2222.0000 4 4 Serial0 frame-relay 16 4 4
```

### Cisco FRAD or FRAS Router B with BAN Configuration Example

```
source-bridge ring-group 200
!
interface Serial0
 encapsulation frame-relay IETF
 frame-relay map llc2 37
 fras ban 10 1 200 4000.3745.0000 dlci 37
!
interface TokenRing0
 source-bridge 20 1 200
```

### Cisco FRAD or FRAS Router C with BAN Configuration Example

```
source-bridge ring-group 400
!
interface Serial0
  encapsulation frame-relay IETF
  frame-relay map llc2 46
  fras ban 50 1 400 4000.3745.0220 dlci 46 bni 4001.3745.1088
!
interface TokenRing0
  source-bridge 60 1 400
```

### FRAS Host CIP Connection to VTAM Configuration Example

The following example shows the configuration for the network shown in Figure 147.

```
source-bridge ring-group 100
!
interface Serial0/1
  encapsulation frame-relay IETF
  frame-relay map llc2 16
  frame-relay map llc2 46
!
interface Serial0/2
  encapsulation frame-relay IETF
!
interface Serial0/2.37 point-to-point
  frame-relay interface-dlci 37
!
interface Channel4/0
  no keepalive
!
interface Channel4/1
  no keepalive
  lan TokenRing 0
  source-bridge 104 1 100
  adapter 0 4001.3745.1008
!
interface Virtual-TokenRing0
  source-bridge 47 1 100
  source-bridge spanning
  fras-host bnn Serial 0/1 fr-lsap 04 vmac 4005.3003.0000 hmac 4001.3745.1088
  fras-host ban Serial 0/1 hmac 4001.3745.1088 bni 4001.3745.1088
  fras-host ban Serial 0/2.37 hmac 4001.3745.1088
```

## FRAS Host Ethernet Connection to AS/400 Configuration Example

The configuration example in this section is shown in Figure 147.

**Figure 147 FRAS Host Ethernet Connection to AS/400**

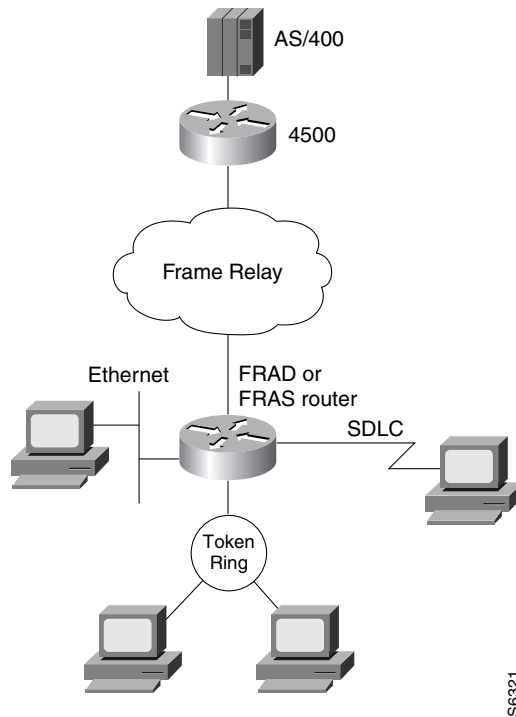

S66321

```

source-bridge ring-group 226
dlsw local-peer
dlsw bridge-group 1
!
interface Ethernet0
 bridge-group 1
!
interface Serial2
 encapsulation frame-relay IETF
 frame-relay map llc2 502
 frame-relay lmi-type ansi
!
interface Virtual-TokenRing0
 no ip address
 ring-speed 16
 source-bridge 1009 1 226
 fras-host dlsw-local-ack
 fras-host bnn Serial2 fr-lsap 04 vmac 4000.1226.0000 hmac 0800.5ae1.151d

```

