

# Cisco 1604 Configuration

This chapter describes how to configure the Cisco 1604 to dial out to the Cisco AS5300.

## Site Profile Characteristics

Figure 3-1 shows the network topology from the Cisco 1604's perspective.

**Figure 3-1 Network Topology**

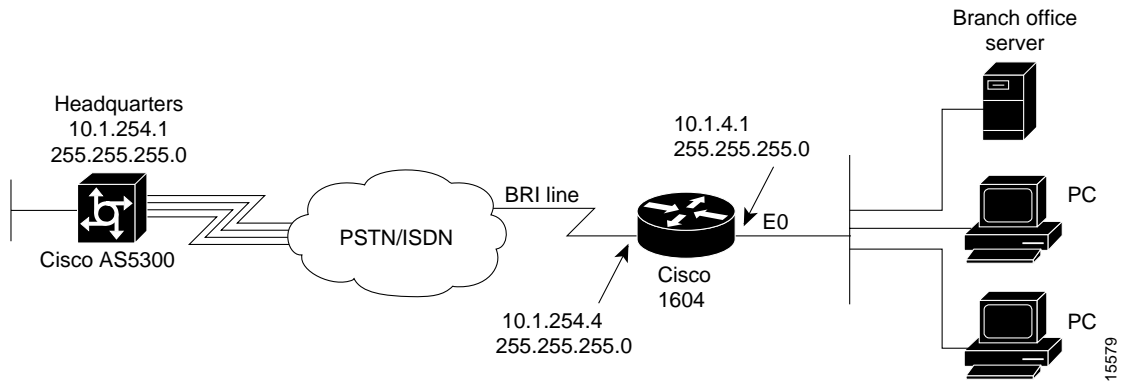

Table 3-1 provides detailed information about the end-to-end connection. This is the network administrator's top-level design table.

**Table 3-1 Site Characteristics**

Host Name/ Username	Username Password	WAN IP Address <sup>1</sup>	Ethernet IP Address	Assigned Phone Number	Site Hardware
robo-austin	austin-pw	10.1.254.4 255.255.255.0	10.1.4.1 255.255.255.0	Directory number = 5125554433	Cisco 1604
hq-sanjose	hq-sanjose-pw	10.1.254.1 255.255.255.0	10.1.1.10 255.255.255.0	4085551234	Cisco AS5300

1. The Cisco 1604's WAN default gateway is 10.1.254.1, which is the Cisco AS5300's dialer interface address.

Cisco IOS Release 12.0 is running inside the router. If the startup configuration is blank, the following screen is displayed at bootup. The automatic setup script is engaged. Enter **no** when you are asked the question, "Would you like to enter the initial configuration dialog? [yes]: **no**."

In this case study, the Cisco 1604 is manually configured. The automatic setup script is not used.

---

**Note** To enhance readability throughout this chapter, the most important output fields are highlighted with **bold** font. The commands you enter are also **bold** but are preceded by a router prompt.

---

```
System Bootstrap, Version 11.1(7)AX [kuong (7)AX], RELEASE SOFTWARE (fc1)
Copyright (c) 1994-1996 by cisco Systems, Inc.
C1600 processor with 2048 Kbytes of main memory
```

```
program load complete, entry point: 0x4018060, size: 0x1da928
```

```
Notice: NVRAM invalid, possibly due to write erase.
```

```
%QUICC_ETHER-1-LOSTCARR: Unit 0, lost carrier. Transceiver problem?program load
complete, entry point: 0x8000060, size: 0x3f5f2c
```

Restricted Rights Legend

Use, duplication, or disclosure by the Government is subject to restrictions as set forth in subparagraph (c) of the Commercial Computer Software - Restricted Rights clause at FAR sec. 52.227-19 and subparagraph (c) (1) (ii) of the Rights in Technical Data and Computer Software clause at DFARS sec. 252.227-7013.

cisco Systems, Inc.  
170 West Tasman Drive  
San Jose, California 95134-1706

```
Cisco Internetwork Operating System Software
IOS (tm) 1600 Software (C1600-SY-L), Version 12.0(x)
Copyright (c) 1986-1998 by cisco Systems, Inc.
Compiled Tue 25-Aug-98 01:45 by xxxx
Image text-base: 0x0802DA90, data-base: 0x02005000
```

```
ROM: System Bootstrap, Version 11.1(10)AA, EARLY DEPLOYMENT RELEASE SOFTWARE (fc1)
```

```
Router uptime is 10 minutes
System restarted by reload
System image file is "flash:c1600-sy-1.120-x"
```

```
cisco 1604 (68360) processor (revision C) with 17920K/512K bytes of memory.
Processor board ID 08823977, with hardware revision 00972006
Bridging software.
X.25 software, Version 3.0.0.
Basic Rate ISDN software, Version 1.1.
1 Ethernet/IEEE 802.3 interface(s)
1 ISDN Basic Rate interface(s)
System/IO memory with parity disabled
2048K bytes of DRAM onboard 16384K bytes of DRAM on SIMM
System running from FLASH
8K bytes of non-volatile configuration memory.
12288K bytes of processor board PCMCIA flash (Read ONLY)
```

```
--- System Configuration Dialog ---

Would you like to enter the initial configuration dialog? [yes/no]: no

Would you like to terminate autoinstall? [yes]: yes

Press RETURN to get started!

00:00:17: %QUICC_ETHER-1-LOSTCARR: Unit 0, lost carrier. Transceiver problem?
00:00:17: %LINK-3-UPDOWN: Interface Ethernet0, changed state to up
00:00:17: %LINK-3-UPDOWN: Interface Serial0, changed state to down
00:00:17: %LINEPROTO-5-UPDOWN: Line protocol on Interface BRI0, changed state to down
00:00:17: %LINEPROTO-5-UPDOWN: Line protocol on Interface BRI0:1, changed state to down
00:00:17: %LINEPROTO-5-UPDOWN: Line protocol on Interface BRI0:2, changed state to down
00:00:17: %LINEPROTO-5-UPDOWN: Line protocol on Interface Ethernet0, changed state to
down
00:00:17: %LINEPROTO-5-UPDOWN: Line protocol on Interface Serial0, changed stat to down
00:00:44: %LINK-5-CHANGED: Interface BRI0, changed state to administratively down
00:00:46: %LINK-5-CHANGED: Interface Serial0, changed state to administratively down
00:00:46: %LINK-5-CHANGED: Interface Ethernet0, changed state to administratively down
00:00:47: %IP-5-WEBINST_KILL: Terminating DNS process

Router>
```

## Overview of Tasks

Perform the following steps to configure the router:

- “Step 1—Configuring the Host Name, Password, and Time Stamps” on page 4
- “Step 2—Configuring Local AAA Security” on page 5
- “Step 3—Configuring the Ethernet Interface” on page 7
- “Step 4—Configuring BRI” on page 9
- “Step 5—Configuring DDR” on page 11
- “Step 6—Testing Connections to the Cisco AS5300” on page 14
- “Step 7—Confirming the Final Running Configuration” on page 21
- “Step 8—Saving the Configuration” on page 21

---

**Note** Before you perform the configuration tasks in this chapter, be sure you understand the overall dial case action plan. See the chapter “Dial Case Study Overview.”

---

## Step 1—Configuring the Host Name, Password, and Time Stamps

Assign a host name to the Cisco 1604, enable basic security, and turn on time stamping. Configuring a host name allows you to distinguish between different network devices. Enable passwords allow you to prevent unauthorized configuration changes. Time stamps help you trace debug output for testing connections. Not knowing exactly when an event occurs hinders you from examining background processes.

### Configure

To configure the host name, enable password, and time stamps, use the following commands beginning in user EXEC mode:

Step	Command	Purpose
1	Router> <b>enable</b>	Enter privileged EXEC mode.
2	Router# <b>configure terminal</b> Enter configuration commands, one per line. End with CNTL/Z.	Enter global configuration mode <sup>1</sup> .
3	Router(config)# <b>hostname robo-austin</b>	Assign a host name to the router. This host name is typically used during authentication with the central site.
4	robo-austin(config)# <b>enable secret guessme</b>	Enter a secret enable password, which secures privileged EXEC mode <sup>2</sup> .
5	hq-sanjose(config)# <b>service password-encryption</b>	Encrypt passwords in the configuration file for greater security <sup>3</sup> .
6	hq-sanjose(config)# <b>service timestamps debug datetime msec</b> hq-sanjose(config)# <b>service timestamps log datetime msec</b>	Enable millisecond time stamping on debug and logging output. Time stamps are useful for detailed access tracing.

1. As you are configuring the software, make sure that all logging dialog generated by the router is displayed on your terminal screen. If it is not, enter the **terminal monitor** EXEC command. If you are configuring the router via the console port, logging is automatically displayed.
2. Make sure to change “guessme” to your own secret password.
3. Additional measures should be used, as the passwords are not strongly encrypted by today’s standards.

### Verify

To verify the configuration:

- Enter the **show running** command:

```

robo-austin# show running
Building configuration...

Current configuration:
!
version 12.0
service timestamps debug uptime
service timestamps log uptime
service password-encryption
!
hostname robo-austin
!
enable secret 5 $1$og7B$nSwMZM0NBKTPHv09KVgxl1
!
interface Ethernet0
no ip address
    
```

```

    shutdown
    !
interface Serial0
    no ip address
    shutdown
    !
interface BRI0
    no ip address
    shutdown
    !
ip classless
!
!
line con 0
line vty 0 4
    login
!

```

- Try logging in with your new enable password. Exit out of enable mode using the **disable** command. The prompt changes from `robo-austin#` to `robo-austin>`. Enter the **enable** command followed by your password. The **show privilege** command shows the current security privilege level, which is level 15.

```

robo-austin# disable
robo-austin> enable
Password: letmein
robo-austin# show privilege
Current privilege level is 15
robo-austin#

```

### Tips

If you have trouble:

- Make sure **Caps Lock** is off.
- Make sure you entered the correct password. Passwords are case sensitive.

## Step 2—Configuring Local AAA Security

The Cisco IOS security model to use on all Cisco devices is authentication, authorization, and accounting (AAA). AAA provides the primary framework through which you set up access control on the access server.

- Authentication—Who are you?
- Authorization—What can you do?
- Accounting—What did you do?

In this case study, the same authentication method is used on all interfaces. AAA is set up to use the local database configured on the router. This local database is created with the **username** configuration commands.

---

**Note** After you finish setting up basic security, you can enhance the security solution by extending it to an external TACACS+ or RADIUS server. This case study describes local AAA security only.

---

## Configure

To configure local AAA security, use the following commands beginning in global configuration mode:

Step	Command	Purpose
1	<code>robo-austin(config)# username joe-admin password joe-password</code>	Create a local username for yourself <sup>1</sup> . This step prevents you from getting locked out of the router when you enable AAA.
2	<code>robo-austin(config)# aaa new-model</code>	Enable AAA access control. This step immediately enables login and PPP authentication.
3	<code>robo-austin(config)# aaa authentication login default local</code>	Configure AAA to perform login authentication using the local username database. The <b>login</b> keyword indicates authentication of EXEC (shell) users.
4	<code>robo-austin(config)# aaa authentication ppp default if-needed local</code>	Configure PPP authentication to use the local database if the session was not already authenticated by <b>login</b> .

1. Make sure to change “joe-admin” to your own username and “joe-password” to your own password.

## Verify

To verify the configuration:

- Try to log in with your username:password. Enter the **login** command at the EXEC (shell) prompt. Do not disconnect your EXEC session until you can log in successfully. (If you get locked out, you will need to perform password recovery by rebooting the router.)

```
robo-austin# login

User Access Verification

Username: joe-admin
Password: joe-password

robo-austin#
```

- Enter the **show running** command:

```
robo-austin# show running
Building configuration...

Current configuration:
!
version 12.0
service timestamps debug uptime
service timestamps log uptime
service password-encryption
!
hostname robo-austin
!
aaa new-model
aaa authentication login default local
aaa authentication ppp default if-needed local
enable secret 5 $1$og7B$nSwMZM0NBKTPhV09KVgx11
```

```

!
username joe-admin password 7 <removed>
!
interface Ethernet0
  no ip address
  shutdown
!
interface Serial0
  no ip address
  shutdown
!
interface BRI0
  no ip address
  shutdown
!
ip classless
!
!
line con 0
line vty 0 4
!

```

## Step 3—Configuring the Ethernet Interface

Assign an IP address to the Ethernet interface. Test the interface by pinging it from a PC on the LAN.

### Configure

To configure the Ethernet interface, use the following commands beginning in global configuration mode:

Step	Command	Purpose
1	<pre> robo-austin(config)# <b>interface ethernet 0</b> robo-austin(config-if)# <b>ip address 10.1.4.1 255.255.255.0</b> </pre>	Configure the IP address and subnet mask on the Ethernet interface.
2	<pre> robo-austin(config-if)# <b>no shutdown</b> </pre>	Bring up the interface <sup>1</sup> .

1. This command changes the state of the interface from administratively down to up.

### Verify

To verify the configuration:

- Enter the **show ip interface brief** command, which allows you to quickly check the status of all router interfaces.

The field “administratively down” means that the interface is configured with the **shutdown** command. To bring the interface up, you must enter the **no shutdown** command. The Status column refers to the ability to physically connect the network at layer 1 (needed for getting clocks and carrier signals). The Protocol column refers to the ability to see traffic flow, which typically occurs at the data link layer. For example, the Ethernet interface sends a loopback Ethernet packet out to itself via the Ethernet LAN.

```

robo-austin# show ip interface brief
Interface          IP-Address      OK? Method Status          Protocol
BRI0                unassigned      YES unset  administratively down down
BRI0:1              unassigned      YES unset  administratively down down
BRI0:2              unassigned      YES unset  administratively down down

```

```

Ethernet0          10.1.4.1          YES manual up          up
Serial0           unassigned        YES unset  administratively down down
  
```

In the next example, notice that the status is up but the protocol is down. The following logging message appears at 00:40:20: “Unit 0, lost carrier. Transceiver problem?.” After the administrator plugs the Ethernet cable into the Ethernet port, the interface comes up. See 00:40:25.

```

robo-austin# show ip interface brief
Interface          IP-Address      OK? Method Status          Protocol
BRI0               unassigned     YES unset  administratively down down
BRI0:1             unassigned     YES unset  administratively down down
BRI0:2             unassigned     YES unset  administratively down down
Ethernet0          10.1.4.1       YES manual up           down
Serial0            unassigned     YES unset  administratively down down
robo-austin#
00:40:20: %QUICC_ETHER-1-LOSTCARR: Unit 0, lost carrier. Transceiver problem?
00:40:25: %LINEPROTO-5-UPDOWN: Line protocol on Interface Ethernet0, changed state to up
robo-austin#
  
```

- Establish connectivity with an Ethernet-based device. In this example, IP address 10.1.4.2 is assigned to the first external PC on this LAN to test for router-to-PC connectivity. The PC’s DOS prompt application is opened and the **ping 10.1.4.1** command is issued.

```

Microsoft(R) Windows 95
(C) Copyright Microsoft Corp 1981-1996.

C:\WINDOWS> ping 10.1.4.1
Pinging 10.1.4.1 with 32 bytes of data:

Reply from 10.1.4.1: bytes=32 time=3ms TTL=236
Reply from 10.1.4.1: bytes=32 time=2ms TTL=236
Reply from 10.1.4.1: bytes=32 time=3ms TTL=236
Reply from 10.1.4.1: bytes=32 time=2ms TTL=236
  
```

- Try pinging the PC from the Cisco 1604. If the PC has not yet used any IP services or drivers, you might get a failure. The preferred method is to ping the router from a PC on the LAN first.

```

robo-austin# ping 10.1.4.2

Type escape sequence to abort.
Sending 5, 100-byte ICMP Echos to 10.1.4.2, timeout is 2 seconds:
!!!!
Success rate is 100 percent (5/5), round-trip min/avg/max = 4/5/8 ms
  
```

- If you know that the Ethernet interface is up but not performing correctly, enter the **show interface ethernet 0** command. This example shows errors in the counters, because the Ethernet cable was not plugged in.

```

robo-austin# show interface ethernet 0
Ethernet0 is up, line protocol is up
Hardware is QUICC Ethernet, address is 0060.834f.6626 (bia 0060.834f.6626)
Internet address is 10.1.4.1/24
MTU 1500 bytes, BW 10000 Kbit, DLY 1000 usec, rely 234/255, load 1/255
Encapsulation ARPA, loopback not set, keepalive set (10 sec)
ARP type: ARPA, ARP Timeout 04:00:00
Last input 00:00:08, output 00:00:04, output hang never
Last clearing of "show interface" counters never
Queueing strategy: fifo
Output queue 0/40, 0 drops; input queue 0/75, 0 drops
5 minute input rate 0 bits/sec, 0 packets/sec
5 minute output rate 0 bits/sec, 0 packets/sec
  2 packets input, 644 bytes, 0 no buffer
  
```

```

Received 2 broadcasts, 0 runts, 0 giants, 0 throttles
0 input errors, 0 CRC, 0 frame, 0 overrun, 0 ignored, 0 abort
0 input packets with dribble condition detected
28 packets output, 2905 bytes, 0 underruns
25 output errors, 0 collisions, 2 interface resets
0 babbles, 0 late collision, 0 deferred
3 lost carrier, 0 no carrier
0 output buffer failures, 0 output buffers swapped out

```

## Step 4—Configuring BRI

Enable BRI connectivity with the central office switch. PPP framing is used on the B channels. Dial-on-demand routing (DDR) is configured in the next section “Step 5—Configuring DDR.”

---

**Note** The **dialer in-band** command does not need to be configured on the BRI interface. A BRI interface is a dialer in-band interface by default. Interface BRI0:1 and BRI0:2 are controlled by the dialer interface “**interface bri 0**.”

---

## Configure

To configure BRI, use the following commands beginning in global configuration mode:

Step	Command	Purpose
1	robo-austin(config)# <b>isdn switch-type basic-ni1</b>	Configure the ISDN switch type, which is <b>basic-ni1</b> in this example.
2	robo-austin(config)# <b>interface bri 0</b> robo-austin(config-if)# <b>ip address 10.1.254.4 255.255.255.0</b>	Configure the IP address and subnet mask on the BRI interface.
3 8	robo-austin(config-if)# <b>isdn spid1 51255544330101</b> robo-austin(config-if)# <b>isdn spid2 51255544340101</b>	Configure your SPIDs, which are required by many switch types.
4	robo-austin(config-if)# <b>encapsulation ppp</b>	Enable PPP.
5	robo-austin(config-if)# <b>no fair-queue</b>	Disable fair queuing.
6	robo-austin(config-if)# <b>ppp multilink</b>	Enable PPP multilink.
7	robo-austin(config-if)# <b>ppp authentication chap pap callin</b>	Enable CHAP and PAP authentication on the interface during LCP negotiation.  The access server will first authenticate with CHAP. If CHAP is not used by the remote client, then PAP is tried. CHAP is requested first. <sup>1</sup>
8	robo-austin(config-if)# <b>no shutdown</b>	Bring up the interface. <sup>2</sup>

1. You have the choice to authenticate the remote side on any connection. The **callin** keyword means that all outbound connection attempts made by the Cisco 1604 will not authenticate the remote peer. The remote peer is the device at the other end of the PPP link (Cisco AS5300). Only the calls that come into the Cisco 1604 will be authenticated.

2. The **no shutdown** command changes the state of the interface from administratively down to up.

## Verify

- You should see the following output messages after you enter the **no shutdown** command.

This example shows the BRI0:1 and BRI0:2 states change to “down,” because the previous state was “administratively down.” The BRI0 D channel changes to “up” as it spoofs for the two B channels. After the D channel finds the B channels, the B channels change state to “up.” The Cisco 1604 communicates with the telephone switch and receives its TEI numbers for its two B channels.

```
robo-austin(config-if)# no shutdown
robo-austin#
00:45:01: %LINK-3-UPDOWN: Interface BRI0:1, changed state to down
00:45:01: %LINK-3-UPDOWN: Interface BRI0:2, changed state to down
00:45:01: %LINK-3-UPDOWN: Interface BRI0, changed state to up
robo-austin#
00:45:02: %ISDN-6-LAYER2UP: Layer 2 for Interface BR0, TEI 100 changed to up
00:45:02: %ISDN-6-LAYER2UP: Layer 2 for Interface BR0, TEI 101 changed to up
robo-austin(config-if)#
```

- Check the ISDN status by entering the **show isdn status** command:

```
robo-austin# show isdn status
Global ISDN Switchtype = basic-ni
ISDN BRI0 interface
    dsl 0, interface ISDN Switchtype = basic-ni
    Layer 1 Status:
        ACTIVE
    Layer 2 Status:
        TEI = 100, Ces = 1, SAPI = 0, State = MULTIPLE_FRAME_ESTABLISHED
        TEI = 101, Ces = 2, SAPI = 0, State = MULTIPLE_FRAME_ESTABLISHED
    Spid Status:
        TEI 100, ces = 1, state = 5(init)
            spid1 configured, no LDN, spid1 sent, spid1 valid
            Endpoint ID Info: epsf = 0, usid = 2, tid = 1
        TEI 101, ces = 2, state = 5(init)
            spid2 configured, no LDN, spid2 sent, spid2 valid
            Endpoint ID Info: epsf = 0, usid = 4, tid = 1
    Layer 3 Status:
        0 Active Layer 3 Call(s)
    Activated dsl 0 CCBs = 0
    Total Allocated ISDN CCBs = 0
```

---

**Note** Here are some defined terms from the output. DSL = Digital Subscriber Loop. CCBs = Call Control Blocks. TEI = Terminal Equipment Identifier. LDN = Local Directory Number. The BRI 0 interface corresponds to dsl 0, which has three channels (2B + D). The CCB counter increases by 1 for each active call on the Cisco 1604. The CCB counter for one call gets destroyed upon disconnect.

---

- Enter the **show ip interface brief** command to check the current state of the interface.

```
robo-austin# show ip interface brief
Interface          IP-Address      OK? Method Status      Protocol
BRI0               10.1.254.4     YES manual up          up
BRI0:1            unassigned     YES unset  down        down
BRI0:2            unassigned     YES unset  down        down
Ethernet0         10.1.4.1       YES manual up          up
Serial0           unassigned     YES unset  administratively down down
```

---

**Note** Notice that the status and protocol for BRI 0 and Ethernet 0 are both up/up, which is what we expect to see. The term manual means that you manually configured the interface since the last reboot. The two B channels (BRI0:1 and BRI0:2) are down because there are no active calls on the BRI interface at this time.

---

### Tips

If you have trouble:

- Make sure the correct ISDN switch type and SPIDs are configured.
- Make sure your BRI line is connected to the correct port.

## Step 5—Configuring DDR

Set up the DDR routing components. In most cases, a remote site with a single LAN will require a simple DDR configuration. DDR is the mechanism that supports the routing table and call control in a circuit switched environment.

DDR in this case study takes the standard dialer map approach. You must configure specific parameters to establish connectivity with the Cisco AS5300 using sync PPP. Parameters include a static route, username:password, and a dialer map.

## Configure

To configure DDR, use the following commands beginning in global configuration mode:

Step	Command	Purpose
1	robo-austin(config)# <b>interface bri 0</b>	Enter configuration mode for the BRI interface.
2	robo-austin(config-if)# <b>dialer-group 2</b>	Define the interesting packets that activate the ISDN connection. Interesting packets reset the idle timer and trigger dialing.  This dialer filter is defined by the <b>dialer-list 2</b> command. See Step 7.
3	robo-austin(config-if)# <b>no fair-queue</b>	Disable fair queuing.
4	robo-austin(config-if)# <b>no cdp enable</b>	Disable the Cisco discovery protocol, unless you are using it for a specific purpose.
5	robo-austin(config-if)# <b>dialer load-threshold 60 either</b>	Configure the interface to bring up the second B channel when the bandwidth load exceeds 60/255.
6	robo-austin(config-if)# <b>dialer map ip 10.1.254.1 name hq-sanjose 14085551234</b> robo-austin(config-if)# <b>exit</b>	Build a dialer map that maps to the Cisco AS5300's IP address, host name, and directory number.  The static route in Step 8 points to this dialer map.
7	robo-austin(config)# <b>dialer-list 2 protocol ip permit</b>	Define a DDR's dialer-list to allow any IP packets to establish and maintain calls.

Step	Command	Purpose
8	robo-austin(config) <b>ip route 0.0.0.0 0.0.0.0 10.1.254.1 permanent</b>	Create a static route for the next hop, which is the Cisco AS5300's WAN port. IP address 10.1.254.1 is used on the Cisco AS5300's dialer interface.  This static route points at the dialer map on the access server's dialer interface.
9	robo-austin(config) <b># username hq-sanjose password austin-pw</b>	When the Cisco AS5300 (hq-sanjose) authenticates the Cisco 1604 using CHAP, this password will be used by the Cisco 1604 <sup>1</sup> .
10	robo-austin(config) <b># ip classless</b>	Ensure that all unknown subnets use the default route.

1. On Cisco IOS devices the PPP name is determined by one of the following commands: **hostname**, **sgbp group**, **ppp pap sent-username**, or **ppp chap hostname**.

## Verify

To verify the configuration:

- Enter the **show ip route** command to confirm that the static route is installed and pointing at your dialer map address. The static IP default route must first be configured before you enter this command.

```
robo-austin# show ip route
Codes: C - connected, S - static, I - IGRP, R - RIP, M - mobile, B - BGP
       D - EIGRP, EX - EIGRP external, O - OSPF, IA - OSPF inter area
       N1 - OSPF NSSA external type 1, N2 - OSPF NSSA external type 2
       E1 - OSPF external type 1, E2 - OSPF external type 2, E - EGP
       i - IS-IS, L1 - IS-IS level-1, L2 - IS-IS level-2, * - candidate default
       U - per-user static route, o - ODR

Gateway of last resort is 10.1.254.1 to network 0.0.0.0

    10.0.0.0/24 is subnetted, 2 subnets
C       10.1.4.0 is directly connected, Ethernet0
C       10.1.254.0 is directly connected, BRI0
S*    0.0.0.0/0 [1/0] via 10.1.254.1
```

---

**Note** The static route is the first software building block (design crux) that receives the packet routed to the dialer map. The route must direct the packets to at the dialer map before the DDR features can establish connectivity.

---

- Enter the **show dialer** command. The following example shows that the Cisco 1604 has not placed any calls yet, and there have been no failures. An ISDN interface is a dialer interface. Key statistics are shown for each B channel.

```
robo-austin# show dialer

BRI0 - dialer type = ISDN

Dial String      Successes  Failures  Last called  Last status
14085551234      0          0         never        -
0 incoming call(s) have been screened.
```

```
0 incoming call(s) rejected for callback.
```

```
BRI0:1 - dialer type = ISDN
Idle timer (120 secs), Fast idle timer (20 secs)
Wait for carrier (30 secs), Re-enable (15 secs)
Dialer state is idle
```

```
BRI0:2 - dialer type = ISDN
Idle timer (120 secs), Fast idle timer (20 secs)
Wait for carrier (30 secs), Re-enable (15 secs)
Dialer state is idle
```

- Enter the **show dialer map** command to view the static dialer map that was built to the Cisco AS5300. This map is built using the phone number and WAN IP address of the access server.

```
robo-austin# show dialer map
Static dialer map ip 10.1.254.1 name hq-sanjose (14085551234) on BRI0
```

- Enter the **show running** command:

```
robo-austin# show running
Building configuration...

Current configuration:
!
version 12.0
service timestamps debug uptime
service timestamps log uptime
service password-encryption
!
hostname robo-austin
!
aaa new-model
aaa authentication login default local
aaa authentication ppp default if-needed local
enable secret 5 $1$aZ1D$wNO71EpS6y5zRYuW9qFEr.
!
username joe-admin password 0 6y5zRYuW9qFEr$wNO71EpS6$aZ1
username hq-sanjose password 0 $wNO71EpS6y5zy5zRYuW9aZ1D$w
isdn switch-type basic-ni
!
interface Ethernet0
 ip address 10.1.4.1 255.255.255.0
!
interface Serial0
 no ip address
 shutdown
!
interface BRI0
 ip address 10.1.254.4 255.255.255.0
 encapsulation ppp
 dialer map ip 10.1.254.1 name hq-sanjose 14085551234
 dialer load-threshold 60 either
 dialer-group 2
 isdn switch-type basic-ni
 isdn spid1 51255544330101
 isdn spid2 51255544340101
 no cdp enable
 ppp authentication chap pap callin
 ppp multilink
 hold-queue 75 in
!
ip classless
ip route 0.0.0.0 0.0.0.0 10.1.254.1 permanent
```

```
!  
dialer-list 2 protocol ip permit  
!  
line con 0  
line vty 0 4  
!  
end
```

### Tips

- To display the actual load currently assigned to the interface, enter the **show interface bri 0:1** command. Search for the output field “load x/255.” SNMP can be used to monitor the load on an interface. How you set the threshold depends on each site’s characteristics, such as traffic patterns and WAN costs. If you are in an environment where all calls are local, then you might nail up the connections full time.
- Large ISDN phone bills arise due to failure to appropriately tune filters and load thresholds. Filters are dialer lists, which are applied with dialer groups. The **dialer-list** command and **dialer-group** command control the first B channel. The **dialer load-threshold** command controls the behavior when additional B channels are connected.
- In this case study, the Cisco AS5300 does not dial out to the remote sites. Therefore, you do not need to tune the central site’s dialer threshold setting. Only the remote side is in charge of opening and closing channels based on the settings of the dialer commands.
- Make sure you configured the correct SPID numbers on the BRI interface.

## Step 6—Testing Connections to the Cisco AS5300

The test strategy is to ping the Cisco AS5300’s WAN port then ping the backbone behind the access server. Cisco recommends you ping the domain name server (DNS) on the backbone, since this device should always be up and operational.

Pinging a next hop IP address can have complications in an IP-unnumbered environment. For example, complications arise when WAN interfaces are configured with IP unnumbered.

---

**Note** The typical low-level test to verify connectivity in a sync PPP environment is to ping a device on the other end of the WAN link. In a modem environment (async PPP), the low-level test is to get an EXEC shell established on the router.

---

Figure 3-2 shows the actual test lab environment used in this test case.

**Figure 3-2 Test Lab Environment**

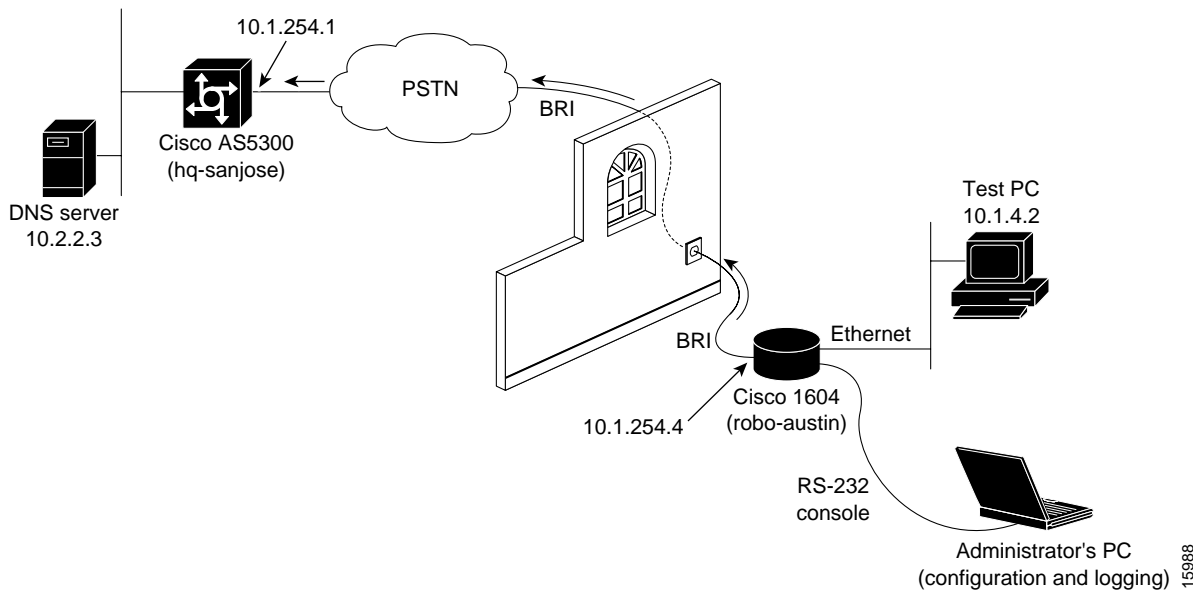

- Step 1** Turn on the appropriate debugging. Examining the background processes is essential for effective troubleshooting.

```

robo-austin# undebug all
All possible debugging has been turned off
robo-austin# terminal monitor
robo-austin# debug dialer
Dial on demand events debugging is on
robo-austin# debug isdn q931
ISDN Q931 packets debugging is on
robo-austin# debug ppp negotiation
PPP protocol negotiation debugging is on
robo-austin# debug ppp authentication
PPP authentication debugging is on
robo-austin# debug ip peer
IP peer address activity debugging is on

```

- Step 2** Verify that your routing table points to the hq-sanjose network access server (NAS):

```

robo-austin# show ip route
Codes: C - connected, S - static, I - IGRP, R - RIP, M - mobile, B - BGP
       D - EIGRP, EX - EIGRP external, O - OSPF, IA - OSPF inter area
       N1 - OSPF NSSA external type 1, N2 - OSPF NSSA external type 2
       E1 - OSPF external type 1, E2 - OSPF external type 2, E - EGP
       i - IS-IS, L1 - IS-IS level-1, L2 - IS-IS level-2, * - candidate default
       U - per-user static route, o - ODR
Gateway of last resort is 10.1.254.1 to network 0.0.0.0
 10.0.0.0/24 is subnetted, 2 subnets
 C    10.1.4.0 is directly connected, Ethernet0
 C    10.1.254.0 is directly connected, BRI0
 S*   0.0.0.0/0 [1/0] via 10.1.254.1

```

**Step 3** Verify that the correct dialer map exists:

```
robo-austin# show dialer map
Static dialer map ip 10.1.254.1 name hq-sanjose (14085551234) on BRI0
```

**Step 4** Ping the IP address assigned to the Cisco AS5300's dialer interface. Notice that the Cisco 1604 (robo-austin) quickly gets 4 of 5 pings back from the Cisco AS5300 (hq-sanjose). After the ping is sent, examine the background processes as displayed by the debug output.

```
robo-austin# ping 10.1.254.1
Type escape sequence to abort.
Sending 5, 100-byte ICMP Echos to 10.1.254.1, timeout is 2 seconds:
..!!!!
Success rate is 80 percent (4/5), round-trip min/avg/max = 116/182/372ms
robo-austin#
```

**Step 5** Look at the debug output. The following comments apply to the debug output example on the next page:

- (a) See 08:03:55.  
The source and destination IP address of the DDR dial cause are displayed.  
(s=10.1.254.4, d=10.1.254.1)
- (b) See 08:03:55.  
Hq-sanjose's hunt group number is dialed.  
(Attempting to dial 14085551234)
- (c) See 08:03:55.  
ISDN Setup is transmitted.  
(TX -> SETUP pd = 8 callref = 0x2F)
- (d) See 08:03:55.  
A synchronous data bearer capability is displayed.  
(Bearer Capability i = 0x8890)
- (e) See 08:03:55.  
The outgoing LCP configuration request is made.  
(BR0:1 LCP: O CONFREQ [Closed] id 42 len 28)
- (f) See 08:03:55.  
The incoming LCP configuration request wants to authenticate with CHAP.  
(AuthProto CHAP (0x0305C22305))
- (g) See 08:03:55.  
The outgoing acknowledgment says this peer will do CHAP.  
(LCP: O CONFACK [REQsent])
- (h) See 08:03:55.  
Both PPP peers have received LCP CONFACK. LCP is now open.  
(BR0:1 LCP: State is Open)
- (i) See 08:03:55.  
Authentication phase is initiated by robo-austin.  
(BR0:1 PPP: Phase is AUTHENTICATING, by the peer)
- (j) See 08:03:55.  
Robo-austin accepts a CHAP challenge initiated by hq-sanjose. The device robo-austin is not authenticating hq-sanjose, which is the desired behavior for this

scenario.

```
(BR0:1 CHAP: I CHALLENGE id 5 len 31 from "hq-sanjose")
```

```
(BR0:1 CHAP: O RESPONSE id 5 len 32 from "robo-austin")
```

(k) See 08:03:55.

The robo-austin PPP peer is successfully authenticated by the hq-sanjose peer.

```
(BR0:1 CHAP: I SUCCESS id 5 len 4)
```

(l) See 08:03:55.

MultiLink PPP uses a virtual-access interface to host the bundle.

```
(BR0:1 PPP: Phase is VIRTUALIZED)
```

(m) See 08:03:56.

LCP on Virtual-Access2 is forced up as it was already negotiated on the physical interface. For more information, use the **show interface virtual-access2 conf** command and **debug vtemp** command.

```
(%LINK-3-UPDOWN: Interface Virtual-Access2, changed state to up)
```

```
(Vi2 PPP: Phase is UP)
```

(n) See 08:03:56.

IPCP negotiation begins.

```
(Vi2 IPCP: O CONFREQ [Closed] id 1 len 10)
```

```
(Vi2 IPCP: Address 10.1.254.4 (0x03060A01FE04))
```

(o) See 08:03:56.

IP can now be used across this PPP connection.

```
(Vi2 IPCP: I CONFACK [ACKsent] id 1 len 10)
```

```
(Vi2 IPCP: State is Open)
```

(p) See 08:03:57.

A route is installed to 10.1.254.1 to match the IP address negotiated by the peer.

```
(BR0 IPCP: Install route to 10.1.254.1)
```

(q) See 08:03:57 and 08:04:01.

The connection is made to hq-sanjose.

```
(Line protocol on Interface Virtual-Access2, changed state to up)
```

```
(Interface BRI0:1 is now connected to 14085551234 hq-sanjose)
```

```
robo-austin# ping 10.1.254.1
Type escape sequence to abort.
Sending 5, 100-byte ICMP Echos to 10.1.254.1, timeout is 2 seconds:
..!!!!
Success rate is 80 percent (4/5), round-trip min/avg/max = 116/182/372ms
robo-austin#
```

```
08:03:55: BRI0: Dialing cause ip (s=10.1.254.4, d=10.1.254.1)
08:03:55: BRI0: Attempting to dial 14085551234
08:03:55: ISDN BR0: TX -> SETUP pd = 8 callref = 0x2F
08:03:55: Bearer Capability i = 0x8890
08:03:55: Channel ID i = 0x83
08:03:55: Keypad Facility i = '14085551234'
08:03:55: ISDN BR0: RX <- CALL_PROC pd = 8 callref = 0xAF
08:03:55: Channel ID i = 0x89
08:03:55: ISDN BR0: RX <- CONNECT pd = 8 callref = 0xAF
08:03:55: ISDN BR0: TX -> CONNECT_ACK pd = 8 callref = 0x2F
08:03:55: %LINK-3-UPDOWN: Interface BRI0:1, changed state to up
08:03:55: BR0:1 PPP: Treating connection as a callout
08:03:55: BR0:1 PPP: Phase is ESTABLISHING, Active Open
08:03:55: BR0:1 PPP: No remote authentication for call-out
08:03:55: BR0:1 LCP: O CONFREQ [Closed] id 42 len 28
08:03:55: BR0:1 LCP: MagicNumber 0x623E5C69 (0x0506623E5C69)
08:03:55: BR0:1 LCP: MRRU 1524 (0x110405F4)
```

## Step 6—Testing Connections to the Cisco AS5300

---

```
08:03:55: BR0:1 LCP: EndpointDisc 1 Local
(0x130E01726F626F2D61757374696E)
08:03:55: BR0:1 LCP: I CONFREQ [REQsent] id 7 len 32
08:03:55: BR0:1 LCP: AuthProto CHAP (0x0305C22305)
08:03:55: BR0:1 LCP: MagicNumber 0xE16A73E6 (0x0506E16A73E6)
08:03:55: BR0:1 LCP: MRRU 1524 (0x110405F4)
08:03:55: BR0:1 LCP: EndpointDisc 1 Local
(0x130D0168712D73616E6A6F7365)
08:03:55: BR0:1 LCP: O CONFACK [REQsent] id 7 len 32
08:03:55: BR0:1 LCP: AuthProto CHAP (0x0305C22305)
08:03:55: BR0:1 LCP: MagicNumber 0xE16A73E6 (0x0506E16A73E6)
08:03:55: BR0:1 LCP: MRRU 1524 (0x110405F4)
08:03:55: BR0:1 LCP: EndpointDisc 1 Local
(0x130D0168712D73616E6A6F7365)
08:03:55: BR0:1 LCP: I CONFACK [ACKsent] id 42 len 28
08:03:55: BR0:1 LCP: MagicNumber 0x623E5C69 (0x0506623E5C69)
08:03:55: BR0:1 LCP: MRRU 1524 (0x110405F4)
08:03:55: BR0:1 LCP: EndpointDisc 1 Local
(0x130E01726F626F2D61757374696E).
08:03:55: BR0:1 LCP: State is Open
08:03:55: BR0:1 PPP: Phase is AUTHENTICATING, by the peer
08:03:55: BR0:1 CHAP: I CHALLENGE id 5 len 31 from "hq-sanjose"
08:03:55: BR0:1 CHAP: O RESPONSE id 5 len 32 from "robo-austin"
08:03:55: BR0:1 CHAP: I SUCCESS id 5 len 4
08:03:55: BR0:1 PPP: Phase is VIRTUALIZED
08:03:55: BR0:1 IPCP: Packet buffered while building MLP bundle
interface
08:03:56: Vi2 PPP: Phase is DOWN, Setup
08:03:56: %LINEPROTO-5-UPDOWN: Line protocol on Interface BRI0:1,
changed state to up
08:03:56: %LINK-3-UPDOWN: Interface Virtual-Access2, changed state to up
08:03:56: Vi2 PPP: Treating connection as a callout
08:03:56: Vi2 PPP: Phase is ESTABLISHING, Active Open
08:03:56: Vi2 PPP: No remote authentication for call-out
08:03:56: Vi2 LCP: O CONFREQ [Closed] id 1 len 28
08:03:56: Vi2 LCP: MagicNumber 0x623E60D6 (0x0506623E60D6)
08:03:56: Vi2 LCP: MRRU 1524 (0x110405F4)
08:03:56: Vi2 LCP: EndpointDisc 1 Local
(0x130E01726F626F2D61757374696E)
08:03:56: Vi2 PPP: Phase is UP
08:03:56: Vi2 IPCP: O CONFREQ [Closed] id 1 len 10
08:03:56: Vi2 IPCP: Address 10.1.254.4 (0x03060A01FE04)
08:03:56: Vi2 PPP: Pending ncpQ size is 1
08:03:56: BR0:1 IPCP: Redirect packet to Vi2
08:03:56: Vi2 IPCP: I CONFREQ [REQsent] id 1 len 10
08:03:56: Vi2 IPCP: Address 10.1.254.1 (0x03060A01FE01)
08:03:56: set_ip_peer_addr: Vi2: address = 10.1.254.1 (7)
08:03:56: Vi2 IPCP: O CONFACK [REQsent] id 1 len 10
08:03:56: Vi2 IPCP: Address 10.1.254.1 (0x03060A01FE01)
08:03:57: Vi2 IPCP: I CONFACK [ACKsent] id 1 len 10
08:03:57: Vi2 IPCP: Address 10.1.254.4 (0x03060A01FE04)
08:03:57: Vi2 IPCP: State is Open
08:03:57: dialer Protocol up for Vi2
08:03:57: BR0 IPCP: Install route to 10.1.254.1
08:03:57: %LINEPROTO-5-UPDOWN: Line protocol on Interface
Virtual-Access2, changed state to up
08:04:01: %ISDN-6-CONNECT: Interface BRI0:1 is now connected to
14085551234 hq-sanjose
```

**Step 6** Ping the DNS server behind hq-sanjose. The DNS server is the first backbone device that Cisco 1604 will try to use. The DNS server in this case study uses 10.2.2.3.

```
robo-austin# ping 10.2.2.3
```

Type escape sequence to abort.

```

Sending 5, 100-byte ICMP Echos to 10.2.2.3, timeout is 2 seconds:
!!!!
Success rate is 100 percent (5/5), round-trip min/avg/max = 4/7/12 ms

```

**Step 7** Use additional commands to verify robo-austin's connection with hq-sanjose:

```

robo-austin# show dialer map
Static dialer map ip 10.1.254.1 name hq-sanjose (14085551234) on BRI0

robo-austin# show dialer

BRI0 - dialer type = ISDN

Dial String      Successes  Failures  Last called  Last status
14085551234      1          0         00:00:30    successful
0 incoming call(s) have been screened.
0 incoming call(s) rejected for callback.

BRI0:1 - dialer type = ISDN
Idle timer (120 secs), Fast idle timer (20 secs)
Wait for carrier (30 secs), Re-enable (15 secs)
Dialer state is multilink member
Dial reason: ip (s=10.1.254.4, d=10.1.254.1)
Connected to 14085551234 (hq-sanjose)

BRI0:2 - dialer type = ISDN
Idle timer (120 secs), Fast idle timer (20 secs)
Wait for carrier (30 secs), Re-enable (15 secs)
Dialer state is idle

Virtual-Access1 - dialer type = IN-BAND SYNC NO-PARITY
Rotary group 0, priority 0
Idle timer (120 secs), Fast idle timer (20 secs)
Wait for carrier (30 secs), Re-enable (15 secs)
Dialer state is data link layer up
Time until disconnect 105 secs
Connected to 14085551234 (hq-sanjose)

robo-austin# show ppp multilink

Bundle hq-sanjose, 1 member, Master link is Virtual-Access1
Dialer Interface is BRI0
  0 lost fragments, 0 reordered, 0 unassigned, sequence 0x0/0x0 rcvd/sent
  0 discarded, 0 lost received, 1/255 load

Member Link: 1(max not set, min not set)
BRI0:1

robo-austin# show interface bri 0:1
BRI0:1 is up, line protocol is up
  Hardware is BRI
  MTU 1500 bytes, BW 64 Kbit, DLY 20000 usec, rely 255/255, load 1/255
  Encapsulation PPP, loopback not set, keepalive set (10 sec)
  LCP Open, multilink Open
  Last input 00:00:07, output 00:00:07, output hang never
  Last clearing of "show interface" counters never
  Queueing strategy: fifo
  Output queue 0/40, 0 drops; input queue 0/75, 0 drops
  5 minute input rate 0 bits/sec, 0 packets/sec
  5 minute output rate 0 bits/sec, 0 packets/sec
    472 packets input, 13496 bytes, 0 no buffer
    Received 469 broadcasts, 0 runts, 0 giants, 0 throttles
    0 input errors, 0 CRC, 0 frame, 0 overrun, 0 ignored, 0 abort
    504 packets output, 18013 bytes, 0 underruns
    0 output errors, 0 collisions, 0 interface resets

```

## Step 6—Testing Connections to the Cisco AS5300

---

```
0 output buffer failures, 0 output buffers swapped out
104 carrier transitions
```

```
robo-austin# show ip interface brief
```

Interface	IP-Address	OK?	Method	Status	Protocol
BRI0	10.1.254.4	YES	manual	up	up
BRI0:1	unassigned	YES	unset	up	up
BRI0:2	unassigned	YES	unset	down	down
Ethernet0	10.1.3.1	YES	manual	up	up
Serial0	unassigned	YES	unset	administratively down	down
Virtual-Access1	unassigned	YES	unset	up	up

```
robo-austin# show interface bri 0 1 2
```

```
BRI0:1 is up, line protocol is up
```

```
Hardware is BRI
```

```
MTU 1500 bytes, BW 64 Kbit, DLY 20000 usec, rely 255/255, load 1/255
```

```
Encapsulation PPP, loopback not set, keepalive set (10 sec)
```

```
LCP Open, multilink Open
```

```
Last input 00:00:00, output 00:00:00, output hang never
```

```
Last clearing of "show interface" counters never
```

```
Queueing strategy: fifo
```

```
Output queue 0/40, 0 drops; input queue 0/75, 0 drops
```

```
5 minute input rate 0 bits/sec, 0 packets/sec
```

```
5 minute output rate 0 bits/sec, 0 packets/sec
```

```
478 packets input, 13592 bytes, 0 no buffer
```

```
Received 474 broadcasts, 0 runts, 0 giants, 0 throttles
```

```
0 input errors, 0 CRC, 0 frame, 0 overrun, 0 ignored, 0 abort
```

```
509 packets output, 18093 bytes, 0 underruns
```

```
0 output errors, 0 collisions, 0 interface resets
```

```
0 output buffer failures, 0 output buffers swapped out
```

```
104 carrier transitions
```

```
BRI0:2 is down, line protocol is down
```

```
Hardware is BRI
```

```
MTU 1500 bytes, BW 64 Kbit, DLY 20000 usec, rely 255/255, load 1/255
```

```
Encapsulation PPP, loopback not set, keepalive set (10 sec)
```

```
LCP Closed, multilink Closed
```

```
Closed: IPCP
```

```
Last input 00:09:36, output 00:09:36, output hang never
```

```
Last clearing of "show interface" counters never
```

```
Queueing strategy: fifo
```

```
Output queue 0/40, 0 drops; input queue 0/75, 0 drops
```

```
5 minute input rate 0 bits/sec, 0 packets/sec
```

```
5 minute output rate 0 bits/sec, 0 packets/sec
```

```
23 packets input, 722 bytes, 0 no buffer
```

```
Received 23 broadcasts, 0 runts, 0 giants, 0 throttles
```

```
0 input errors, 0 CRC, 0 frame, 0 overrun, 0 ignored, 0 abort
```

```
22 packets output, 727 bytes, 0 underruns
```

```
0 output errors, 0 collisions, 0 interface resets
```

```
0 output buffer failures, 0 output buffers swapped out
```

```
2 carrier transitions
```

```
robo-austin# show user
```

Line	User	Host(s)	Idle	Location
* 0 con 0	admin	idle	0	
BR0:1	hq-sanjoe	Sync PPP	00:00:38	

## Step 7—Confirming the Final Running Configuration

Here is the final running configuration for the Cisco 1604:

```
robo-austin# show running
Building configuration...
Current configuration:
!
version 12.0
service timestamps debug uptime
service timestamps log uptime
service password-encryption
!
hostname robo-austin
!
aaa new-model
aaa authentication login default local
aaa authentication ppp default if-needed local
enable secret 5 $1$aZlD$wNO71EpS6y5zRYuW9qFEr.
!
username joe-admin password 7 <removed>
username hq-sanjose password 7 <removed>
isdn switch-type basic-ni!
!
interface Ethernet0
 ip address 10.1.4.1 255.255.255.0
!
interface BRI0
 ip address 10.1.254.4 255.255.255.0
 encapsulation ppp
 no ip route-cache
 dialer map ip 10.1.254.1 name hq-sanjose 14085551234
 dialer load-threshold 60 either
 dialer-group 2
 isdn switch-type basic-ni
 isdn spid1 51255544330101
 isdn spid2 51255544340101
 no cdp enable
 ppp authentication chap callin
 ppp multilink
 hold-queue 75 in
!
ip classless
ip route 0.0.0.0 255.0.0.0 10.1.254.1 permanent
!
!
dialer-list 2 protocol ip permit
!
line con 0
line vty 0 4
!
end
```

## Step 8—Saving the Configuration

Save the configuration to NVRAM by entering the **copy running-config startup-config** command.

