

Configuring Multiport T1/E1 ATM Network Modules with Inverse Multiplexing over ATM on Cisco 2600 and 3600 Series Routers

This document describes the Cisco IOS Inverse Multiplexing for ATM (IMA) features available with the introduction of Multiport T1/E1 ATM network modules with IMA for the Cisco 2600 and 3600 series routers. It includes the following sections:

- Feature Overview, page 1
- Supported Platforms, page 6
- Supported Standards, MIBs, and RFCs, page 6
- Prerequisites, page 6
- Configuration Tasks, page 7
- Monitoring and Maintaining ATM Inverse Multiplexing, page 18
- Configuration Examples, page 18
- Command Reference, page 23
- Debug Command, page 49
- Glossary, page 52

Feature Overview

Inverse multiplexing provides the capability to transmit and receive a single high-speed data stream over multiple slower-speed physical links. In inverse multiplexing over ATM, the originating stream of ATM cells is divided so that complete ATM cells are transmitted in round-robin order across the set of ATM links.

Asynchronous Transfer Mode (ATM) T1 and E1 IMA network modules provide four or eight T1 or E1 ports with inverse multiplexing capability. These modules allow wide-area networking (WAN) uplinks at speeds ranging from 1.536 Mbps to 12.288 Mbps for T1, and from 1.92 Mbps to 15.36 Mbps for E1. See the “Bandwidth Considerations” section on page 4.

Cisco’s scalable ATM IMA solution means that you can deploy just the bandwidth you need by using multiple E1 or T1 connections instead of a more expensive E3, T3, or OC-3 to bridge between LANs and ATM WAN applications. Enterprises and branch offices can aggregate traffic from multiple low-bandwidth digital physical transmission media, such as T1 pipes, to transmit voice and data at high-bandwidth connection speeds. For example, Figure 1 illustrates a scenario where an organization must transport a mission-critical application among headquarters and branch offices at 6 Mbps.

Figure 1 LAN-to-WAN Application Connectivity with T1 and IMA

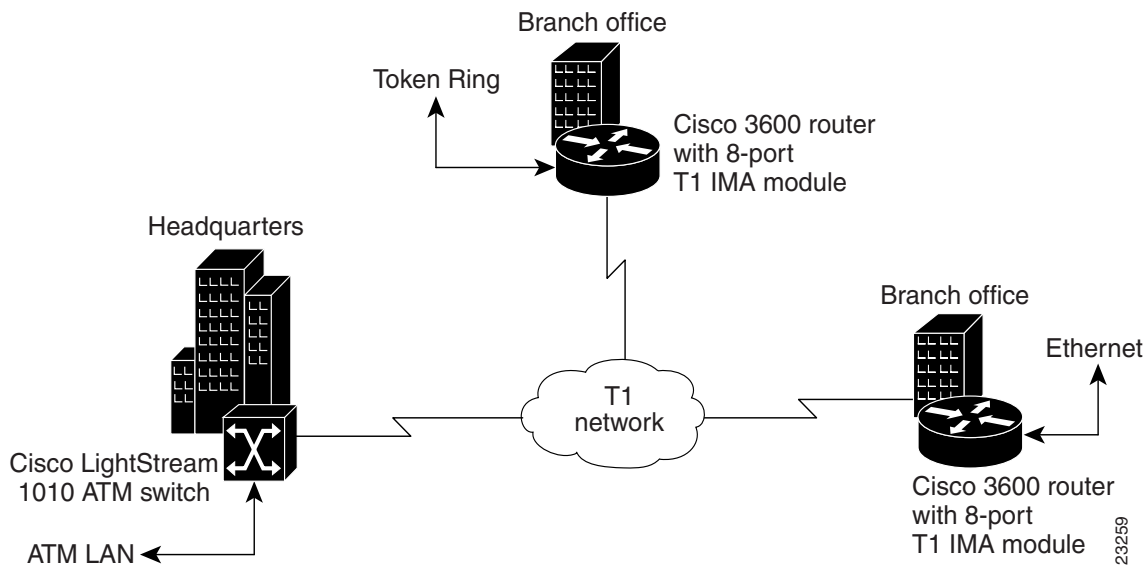

IMA Protocol Overview

In the transmit direction, IMA takes cells from the ATM layer and sends them in a round-robin order over the individual links that make up a logical link group called an IMA group (links can also be assigned as individuals rather than as group members). The IMA group performance is approximately the sum of the links, although some overhead is required for ATM control cells. At the receiving end, the cells are recombined to form the original cell stream and are passed up to the ATM layer.

Filler cells are used to ensure a steady stream on the receiving side. IMA control protocol (ICP) cells control the operation of the inverse multiplexing function. Using a frame length of 128, one out of every 128 cells on each link is an ICP cell. The inverse multiplexing operation is transparent to the ATM layer protocols; therefore, the ATM layer can operate normally as if only a single physical interface were being used.

Figure 2 illustrates inverse multiplexing and demultiplexing with four bundled links, providing 6.144 Mbps of bandwidth for T1s and 7.68 Mbps of bandwidth for E1 for packet traffic. The transmit side, where cells are distributed across the links, is referred to as *Tx*, and the receive side, where cells are recombined, is called *Rx*.

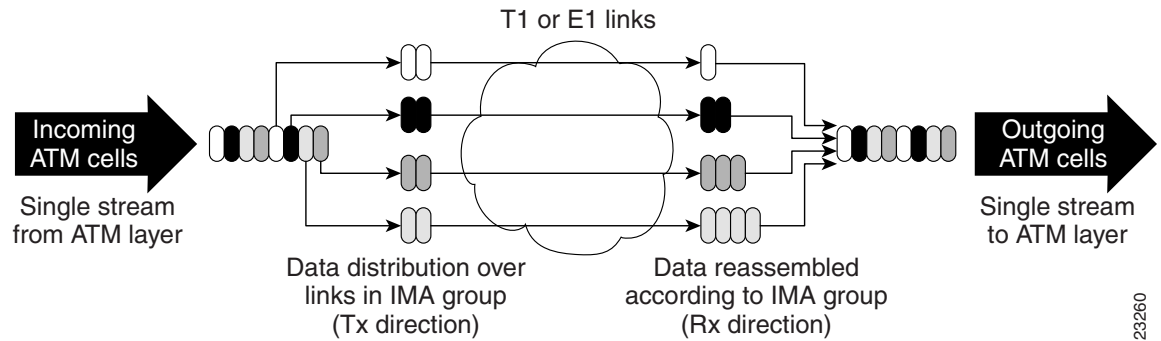
Figure 2 Inverse Multiplexing and Demultiplexing

23260

General Description of the ATM T1/E1 IMA Feature Set

ATM networks were designed to handle the demanding performance needs of voice, video, and data at broadband speeds of 34 Mbps and above. However, the high cost and spotty availability of long-distance broadband links limits broadband ATM WANs, preventing many organizations from taking advantage of ATM's power. In response to these issues, the ATM Forum defined lower-speed ATM interface options for T1 and E1. However, this was not a complete solution because a single T1 or E1 link often does not provide enough bandwidth to support either traffic among different router and switch locations or heavy end-user demand.

For this reason, many organizations find themselves caught between the bandwidth limitations of a narrowband T1 or E1 line and the much higher costs of moving to broadband links. In response to this dilemma, the ATM Forum, with Cisco as an active member, defined Inverse Multiplexing for ATM (IMA). Using Cisco 2600 and 3600 series routers to provide ATM access gives branch offices and enterprises an affordable LAN-to-ATM interface.

ATM IMA T1/E1 support on the Cisco 2600 and 3600 series routers includes the following features:

- Prioritization of ATM transport, including the following traffic classes:
 - Real-time and non-real-time variable bit rate (VBR) connection-oriented service suitable for video and voice
 - Available bit rate (ABR) connection-oriented service for traffic, such as LAN interconnections and TCP/IP connectivity that work well with variable delays
 - Unspecified bit rate (UBR), as recognized by the ATM Forum, without resource allocation or quality of service (QoS) specifications
- Cell-based inverse multiplexing that allows operation, administration, and maintenance (OAM) cells to provide management and monitoring, which performs across the imuxed (inverse multiplexed) links. In this fashion, a Cisco 2600 or 3600 router with ATM IMA functionality can exchange monitoring information, such as connectivity, alarm indication signals (AIS), and loopback.
- Permanent virtual connections (PVCs) as well as the switched virtual connections (SVCs) being introduced by carriers. Up to 256 virtual circuits are supported on each interface.
- ATM Interim Local Management Interface (ILMI) as specified by the ATM Forum for incorporating network-management capabilities

- Automatic and dynamic removal of failed links or those not performing according to delay standards—along with automatic and dynamic restoration when the links are up or when delays are acceptable
- Interoperation with the Cisco LS1010, ATM interfaces on Cisco 7200 and 7500 series routers, and Cisco BPX 8600 series wide-area ATM switches
- AAL5

Benefits

The following benefits are offered by the ATM T1/E1 IMA features for the Cisco 2600 and 3600 series routers:

- High-bandwidth performance at a lower cost than T3 and E3
- Internetworking design flexibility and scalability for LAN-to-WAN solutions
- Migration path to high bandwidth without the need to change transport facilities
- Efficient prioritization provided by the ATM architecture

Restrictions

This section describes general restrictions and ATM aspects that the ATM IMA feature does not support as well as bandwidth considerations.

General Limitations

The following restrictions apply to the ATM IMA feature on the Cisco 2600 and 3600 series:

- The ATM IMA T1 and E1 network modules interoperate with the Cisco 3810 multiservice access concentrator, but only when the Cisco MC3810 is in UNI mode, and only when the T1 or E1 links operate as individual links—not as IMA groups.
- IMA frame length is automatically set to 128. You cannot configure a different frame length.
- The feature does not support AAL1, AAL2, and AAL3/AAL4.
- The feature does not support the ATM Constant Bit Rate (CBR) traffic class.

Bandwidth Considerations

When planning IMA groups and payload bandwidth requirements, consider the overhead required for ATM cell headers, service-layer encapsulation such as RFC 1483, AAL5 encapsulation, and ICP cells. Table 1 and Table 2 show approximate values for T1 and E1 IMA groups, respectively with a frame length of 128, estimating ATM overhead at about 10 percent. The effective payload bandwidth varies based on packet size because the packets must be divided into an integer number of ATM cells leaving the last cell padded with filler bytes.

Note Control the bandwidth threshold to activate an IMA group by using the **ima active-links-minimum** command. For additional information, see “ima active-links-minimum” on page 32.

Table 1 T1 IMA AAL5 Payload Bandwidth; IMA Frame Size 128

Number of Links in the Group	Total Bandwidth	Payload Bandwidth
1	1.536	1.38
2	3.072	2.76
3	4.608	4.14
4	6.144	5.52
5	7.68	6.91
6	9.216	8.28
7	10.752	9.66
8	12.288	11.04

Table 2 E1 AAL5 Payload IMA Bandwidth; IMA Frame Size 128

Number of Links in the Group	Total Bandwidth	Payload Bandwidth
1	1.92	1.74
2	3.84	3.47
3	5.76	5.21
4	7.68	6.95
5	9.60	8.69
6	11.52	10.43
7	13.44	12.17
8	15.36	13.90

Related Documents

The following Cisco IOS Release 12.0 documents provide information about ATM configuration:

- *Wide-Area Networking Configuration Guide*
- *Wide-Area Networking Command Reference*

For information about the physical characteristics of the ATM T1/E1 IMA network modules, or for instructions on how to install the network or modem modules, either see the Cisco 2600 or 3600 series *Network Module Hardware Installation Guide* that came with your ATM T1/E1 IMA network module or view the up-to-date information on CCO.

Supported Platforms

The ATM IMA feature is supported on the following modular access routers:

- Cisco 3640
- Cisco 3620
- Cisco 2610
- Cisco 2611
- Cisco 2612
- Cisco 2613
- Cisco 2620
- Cisco 2621

Supported Standards, MIBs, and RFCs

This feature supports the following MIBs:

- IMA MIB (ATM Forum, AF-PHY-0086.001)
- DS1/E1 MIB (as defined in RFC 1406)
- Chassis MIB

For descriptions of supported MIBs and how to use MIBs, see Cisco's MIB website on CCO at <http://www.cisco.com/public/sw-center/netmgmt/cmtk/mibs.shtml>.

This feature supports the following RFCs:

- RFC 1573—`ifGeneralGroup` and `ifStackGroup` from the Interfaces Group of MIB-II
- RFC 1577
- RFC 1483

Prerequisites

Before you can configure a Cisco 2600 or 3600 series router to provide ATM IMA T1/E1 service, you must perform the following tasks:

- Obtain T1 or E1 service from your telecommunications provider.
- Install a multiport T1/E1 ATM network module with IMA into your Cisco router. One of the following multiport T1/E1 ATM network module with IMA is required to support inverse multiplexed ATM on the Cisco 2600 and 3600 series routers:
 - NM-4T-IMA—Four-port ATM network module providing T1 connectivity.
 - NM-8T-IMA—Eight-port ATM network module providing T1 connectivity.
 - NM-4E-IMA—Four-port ATM network module providing E1 connectivity.
 - NM-8E-IMA—Eight-port ATM network module providing E1 connectivity.

Configuration Tasks

This section describes the configuration tasks required in order to set up ATM IMA groups. You can also configure ATM links individually, but this feature description only includes those individual configuration steps that may pertain to ATM IMA groups.

Perform the following configuration tasks in order to enable ATM inverse multiplexing:

- Configure the ATM interfaces to specify the links that are part of IMA groups.
- Configure the IMA group functions.

Configuring the ATM Interface

Repeat the steps below to configure each ATM interface for ATM IMA operation.

Step	Command	Purpose
1	Router# configure terminal	Enter global configuration mode.
1	Router(config)# interface atm slot/port	<p>Enter interface configuration mode and specify the location of the interface.</p> <p>The <i>slot</i> value indicates the router slot position of the installed network module. Depending on the router, enter a slot value from 0 to 3.</p> <p>The <i>port</i> value indicates the T1 or E1 link that you are configuring. Enter a value from 0 to 3 or from 0 to 7, depending on whether the network module has four ports or eight ports. Cisco IOS creates the interfaces automatically when a module is installed.</p>
2	Router(config-if)# clock source {line internal loop-timed}	<p>The clock source command sets the clock source for a link.</p> <p>line specifies that the link uses the recovered clock from the link and is the default setting. Generally, this setting is most reliable.</p> <p>internal specifies that the DS1 link uses the internal clock.</p> <p>loop-timed specifies that the T1 or E1 interface takes the clock from the Rx (line) and uses it for Tx. If the ATM interface is part of an IMA group, you can use the loop-timed keyword to specify that the clock source is the same as the IMA group clock source.</p> <p>Note Ensure that clock settings are properly configured for each link even when you intend to use a common link for clocking all the links in an IMA group. See the “ima clock-mode” section on page 33.</p>

Configuring the ATM Interface

Step	Command	Purpose
3	<pre>Router(config-if)# cablelength long {gain26 gain36} {-15db -22.5db -7.5db 0db}</pre> <p>or</p> <pre>cablelength short {133 266 399 533 655}</pre>	<p>(T1 interfaces only) To set a cable length longer than 655 feet for a T1 link, use the cablelength long command. The keywords are as follows:</p> <ul style="list-style-type: none">• gain26 specifies the decibel pulse gain at 26. This is the default pulse gain.• gain36 specifies the decibel pulse gain at 36.• -15db specifies the decibel pulse rate at -15 decibels.• -22.5db specifies the decibel pulse rate at -22.5 decibels.• -7.5db specifies the decibel pulse rate at -7.5 decibels.• 0db specifies the decibel pulse rate at 0 decibels. This is the default pulse rate. <p>To set a cable length 655 feet or shorter for a T1 link, use the cablelength short command. There is no default for cablelength short. The keywords are as follows:</p> <ul style="list-style-type: none">• 133 specifies a cable length from 0-133 feet.• 266 specifies a cable length from 134-266 feet.• 399 specifies a cable length from 267-399 feet.• 533 specifies a cable length from 400-533 feet.• 655 specifies a cable length from 534-655 feet. <p>If you do not set the cable length, the system defaults to a setting of cablelength long gain26 0db.</p>
4	<pre>Router(config-if)# no ip address</pre>	<p>Instead of configuring protocol parameters on the physical interface, you can set up the parameters on the IMA group virtual interface.</p>
5	<pre>Router(config-if)# no atm oversubscribe</pre>	<p>The no atm oversubscribe command¹ enables the ATM bandwidth manager, which keeps track of bandwidth used by virtual circuits on a per-interface basis. This is useful because many services, such as ABR and VBR-RT, require guaranteed bandwidth. When you specify the no form of the command, a check determines whether the ATM link is already oversubscribed. If it is, the command is rejected. Otherwise, the total bandwidth available on the link is recorded and all future connection setup requests are monitored to ensure that the link is not oversubscribed.</p>
6	<pre>Router(config-if)# no scrambling payload</pre>	<p>Normally, the default setting for this command is sufficient. Helping to ensure reliability, scrambling randomizes the ATM cell payload frames to avoid continuous non-variable bit patterns and improve the efficiency of ATM's cell delineation algorithms. By default, payload scrambling is on for E1 links and off for T1 links.</p>

Step	Command	Purpose
7	Router(config-if)# impedance { 75-ohm 120-ohm }	<p>(E1 interfaces only) This command specifies the impedance (amount of wire resistance and reactivity to current) for the E1 link. Impedance levels are maintained to avoid data corruption over long-distance links. The impedance is determined by the dongle-type cable that you plug in to the IMA module. Set this command to match that cable.</p> <p>Specify 120-ohm to match the unbalanced twisted-pair 120-ohm interface. This is the default.</p> <p>75-ohm is for a balanced BNC 750-ohm interface.</p>
8	Router(config-if)# loopback [line local payload remote]	<p>(For testing only) This command is useful for testing because it loops all packets from the ATM interface back to the interface and directs the packets to the network.</p> <p>The default line setting places the interface into external loopback mode at the line.</p> <p>remote keeps the local end of the connection in remote loopback mode.</p> <p>local places the interface into local loopback mode.</p> <p>payload places the interface into external loopback at the payload level.</p>
9	Router(config-if)# fdl { att ansi all none }	<p>(Optional, T1 only) This command sets the Facility Data Link (FDL) exchange standard for the CSU controllers. The FDL is a 4-Kpbs channel used with the Extended SuperFrame (ESF) framing format to provide out-of-band messaging for error-checking on a T1 link.</p> <p>Note For T1, ESF framing and binary eight zero substitution (B8ZS) line encoding are set. For E1, CRC4 multiframe framing and HDB3 line encoding are set. These are the parameters specified by the ATM Forum, and they cannot be changed.</p> <p>You should generally leave this setting at the default, ansi, which follows the ANSI T1.403 standard for extended superframe facilities data link exchange support. Changing it allows improved management in some cases but can cause problems if your setting is not compatible with that of your service provider.</p> <p>att selects the AT&T TR54016 standard for extended superframe facilities data link exchange support.</p> <p>all enables both of the above standards.</p> <p>none means that there is no standard supported for the FDL exchange standard.</p>
10	Router(config-if)# ima-group <i>group-number</i>	<p>This command specifies that the link is included in an IMA group. Enter an IMA group number from 0 to 3. You can specify up to four groups for each IMA network module. IMA groups usually span multiple ports on a module.</p>
11	Router(config-if)# no shutdown	<p>This command ensures that the link is active at the IMA level. If shut down, the link is added to the group but put in an inhibited state.</p>

1 This command was introduced in Cisco IOS Release 12.0(3)T. For more information, see the online feature description, *ATM OC-3 Network Module for the Cisco 3600 Series Routers*, on CCO at http://www.cisco.com/univercd/cc/td/doc/product/software/ios120/120newft/120t/120t3/oc3_fm.htm.

Verifying the ATM Interface Configuration

Follow the steps below to verify the configuration of ATM interfaces.

- Step 1** Enter the privileged EXEC **show interface atm slot/port** command to verify the configuration of the ATM interface. Important information appears in bold. Notice that the total count of configured virtual circuits (VCs) is shown.

```
router# show interface atm0/1
ATM0/1 is up, line protocol is up
Hardware is ATM T1
Internet address is 21.1.1.2/8
MTU 4470 bytes, sub MTU 4470, BW 1500 Kbit, DLY 20000 usec,
    reliability 0/255, txload 1/255, rxload 1/255
Encapsulation ATM, loopback not set
Keepalive not supported
Encapsulation(s): AAL5
256 maximum active VCs, 3 current VCCs
VC idle disconnect time: 300 seconds
Last input never, output never, output hang never
Last clearing of "show interface" counters never
Queueing strategy: fifo
Output queue 0/40, 0 drops; input queue 0/75, 0 drops
5 minute input rate 0 bits/sec, 0 packets/sec
5 minute output rate 0 bits/sec, 0 packets/sec
    0 packets input, 0 bytes, 0 no buffer
    Received 0 broadcasts, 0 runts, 0 giants, 0 throttles
    0 input errors, 0 CRC, 0 frame, 0 overrun, 0 ignored, 0 abort
    0 packets output, 0 bytes, 0 underruns
    0 output errors, 0 collisions, 3 interface resets
    0 output buffer failures, 0 output buffers swapped out
```

- Step 2** To get information about the physical link, enter the privileged EXEC **show controller atm [slot/port]** command.

```
router# show controller atm0/2
Interface ATM0/2 is administratively down
Hardware is ATM T1
LANE client MAC address is 0050.0f0c.1482
hwidb=0x617BEE9C, ds=0x617D498C
slot 0, unit 2, subunit 2
rs8234 base 0x3C000000, slave base 0x3C000000
rs8234 ds 0x617D498C
SBDs - avail 2048, guaranteed 2, unguaranteed 2046, starved 0
Seg VCC table 3C00B800, Shadow Seg VCC Table 617EF76C, VCD Table 61805798
Schedule table 3C016800, Shadow Schedule table 618087C4, Size 63D
RSM VCC Table 3C02ED80, Shadow RSM VCC Table 6180C994
VPI Index Table 3C02C300, VCI Index Table 3C02E980
Bucket2 Table 3C01E500, Shadow Bucket2 Table 6180A0E4
MCR Limit Table 3C01E900, Shadow MCR Table 617D2160
ABR template 3C01EB00, Shadow template 614DEEAC
RM Cell RS Queue 3C02C980
Queue TXQ Addr Pos StQ Addr Pos
0 UBR CHN0 3C028B00 0 03118540 0
1 UBR CHN1 3C028F00 0 03118D40 0
2 UBR CHN2 3C029300 0 03119540 0
3 UBR CHN3 3C029700 0 03119D40 0
4 VBR/ABR CHN0 3C029B00 0 0311A540 0
5 VBR/ABR CHN1 3C029F00 0 0311AD40 0
6 VBR/ABR CHN2 3C02A300 0 0311B540 0
7 VBR/ABR CHN3 3C02A700 0 0311BD40 0
8 VBR-RT CHN0 3C02AB00 0 0311C540 0
9 VBR-RT CHN1 3C02AF00 0 0311CD40 0
10 VBR-RT CHN2 3C02B300 0 0311D540 0
11 VBR-RT CHN3 3C02B700 0 0311DD40 0
```

```

12 SIG          3C02BB00 0   0311E540 0
13 VPD          3C02BF00 0   0311ED40 0

Queue          FBQ Addr  Pos  RSQ Addr  Pos
0 OAM          3C0EED80 255 0311F600 0
1 UBR CHN0     3C0EFD80 0   03120600 0
2 UBR CHN1     3C0F0D80 0   03121600 0
3 UBR CHN2     3C0F1D80 0   03122600 0
4 UBR CHN3     3C0F2D80 0   03123600 0
5 VBR/ABR CHN0 3C0F3D80 0   03124600 0
6 VBR/ABR CHN1 3C0F4D80 0   03125600 0
7 VBR/ABR CHN2 3C0F5D80 0   03126600 0
8 VBR/ABR CHN3 3C0F6D80 0   03127600 0
9 VBR-RT CHN0  3C0F7D80 0   03128600 0
10 VBR-RT CHN1 3C0F8D80 0   03129600 0
11 VBR-RT CHN2 3C0F9D80 0   0312A600 0
12 VBR-RT CHN3 3C0FAD80 0   0312B600 0
13 SIG          3C0FBD80 255 0312C600 0
SAR Scheduling channels: -1 -1 -1 -1 -1 -1 -1 -1

```

Part of IMA group 3

Link 2 IMA Info:

```

group index is 1
Tx link id is 2, Tx link state is unusableNoGivenReason
Rx link id is 99, Rx link state is unusableFault
Rx link failure status is fault,
0 tx failures, 3 rx failures

```

Link 2 Frammer Info:

```

framing is ESF, line code is B8ZS, fd1 is ANSI
cable-length is long, Rcv gain is 26db and Tx gain is 0db,
clock src is line, payload-scrambling is disabled, no loopback
line status is 0x1064; or Tx RAI, Rx LOF, Rx LOS, Rx LCD.
port is active, link is unavailable
0 idle rx, 0 correctable hec rx, 0 uncorrectable hec rx
0 cells rx, 599708004 cells tx, 0 rx fifo overrun.

```

Link (2):DS1 MIB DATA:

```

Data in current interval (518 seconds elapsed):
0 Line Code Violations, 0 Path Code Violations
0 Slip Secs, 518 Fr Loss Secs, 0 Line Err Secs, 0 Degraded Mins
0 Errored Secs, 0 Bursty Err Secs, 0 Severely Err Secs, 519 Unavail Secs
Total Data (last 24 hours)
0 Line Code Violations, 0 Path Code Violations,
0 Slip Secs, 86400 Fr Loss Secs, 0 Line Err Secs, 0 Degraded Mins,
0 Errored Secs, 0 Bursty Err Secs, 0 Severely Err Secs, 86400 Unavail Secs

```

SAR counter totals across all links and groups:

```

0 cells output, 0 cells stripped
0 cells input, 0 cells discarded, 0 AAL5 frames discarded
0 pci bus err, 0 dma fifo full err, 0 rsm parity err
0 rsm syn err, 0 rsm/seg q full err, 0 rsm overflow err
0 hs q full err, 0 no free buff q err, 0 seg underflow err
0 host seg stat q full err

```

Configuring IMA Groups

As shown in the previous section, the **ima-group** command configures links on an ATM interface as IMA group members. When IMA groups have been set up in this way, you can configure settings for each group.

Step	Command	Purpose
1	Router# configure terminal	Enter global configuration mode.
2	Router(config)# interface atm slot/imagroup-number	<p>Enter interface configuration mode and specify the slot location of the interface and IMA group number.</p> <p>The <i>slot</i> value indicates the router slot where the network module is located. depending on the router, enter a slot value from 0 to 3.</p> <p>The <i>group-number</i> is the IMA group label. Enter a value from 0 to 3. Do not leave a space between “ima” and the group number.</p>
3	Router(config-if)# ip address ip-address	You can set protocol parameters for the whole group.
4	Router(config-if)# pvc vpi/vci ilmi	<p>If you are going to use SVCs, create an ATM permanent virtual circuit (PVC) for ILMI management purposes and enter VC configuration mode. To set up communication with the ILMI, use a value of ilmi for ATM adaptation layer encapsulation; the associated <i>vpi</i> and <i>vci</i> values are ordinarily 0 and 16, respectively.</p> <p>Note This command is new to the Cisco 2600 and 3600 series, but was introduced for other platforms in prior releases.</p>
5	Router(config-if-atm-vc)# pvc vpi/vci qsaal	<p>To enable the signaling for setup and tear-down of SVCs, specify the Q.SAAL (Signaling ATM Adaptation Layer) encapsulation; the associated <i>vpi</i> and <i>vci</i> values are ordinarily 0 and 5, respectively.</p> <p>Note You can also set up PVCs for sending information.</p>
6	Router(config-if)# svc name nsap nsap-address	<p>You can also set up SVCs for sending ATM information. Once you specify a name for an SVC, you can re-enter the interface-ATM-VC configuration mode by simply entering svc name.</p> <p><i>nsap-address</i> is a 40-digit hexadecimal number.</p>
7	Router(config-if-atm-vc)# protocol ip address broadcast	<p>You can specify a protocol address for the SVC.</p> <p>Note The default AAL5 layer and SNAP encapsulation is used in this example, so the encapsulation aalencap command is unnecessary.</p>

Step	Command	Purpose
8	Router(config-if-atm-vc)# vbr-rt <i>peak-rate average-rate burst</i>	<p>You can configure a type of ATM service on the SVC. This example uses Variable Bit Rate, real-time, for AAL5 communications, allowing you to set different cell rate parameters for connections where there is a fixed timing relationship among samples. (VBR is generally used with AAL5 and IP over ATM.) The command configures traffic shaping, so that the carrier does not discard calls. Configure the burst value if the SVC will carry bursty traffic.¹</p> <p>The default is UBR at the maximum line rate of the physical interface, but for an SVC on an IMA group, configure one of the services listed below, or use the vbr-rt command described above. The <i>-pcr</i> and <i>-mcr</i> arguments are the peak cell rate and minimum cell rate, respectively. The <i>-scr</i> and <i>-mbs</i> arguments are the sustainable cell rate and maximum burst size respectively.</p> <ul style="list-style-type: none"> • abr <i>output-pcr output-mcr</i> for best-effort Available Bit Rate traffic for such applications as LAN interconnections and TCP/IP where a guaranteed cell rate is not required. The peak cell <i>-pcr</i> specifies the maximum value of the allowed cell rate (ACR), and minimum cell rate <i>-mcr</i> specifies the minimum value for the ACR. • vbr-nrt <i>output-pcr output-scr output-mbs [input-pcr] [input-scr] [input-mbs]</i> for Variable Bit Rate, non-real-time traffic where no fixed timing relationship exists between samples. • ubr <i>output-pcr [input-pcr]</i> for Unassigned Bit Rate traffic where any amount of data up to the specified maximum can be sent, but there are no guarantees in terms of cell loss rate and delay.
9	Router(config-if-atm-vc)# exit	Exit VC configuration mode and return to interface configuration mode.
10	Router(config-if)# ima clock-mode { common [<i>port</i>] independent }	<p>To set the transmit clock mode for the group, use this command.</p> <p>If all the links in the group should share a clock source, use the common keyword.</p> <p>If each link uses a different clock source, use the independent clock source keyword. The optional <i>port</i> keyword allows you to specify a link to be used for common clocking. The default uses the common clock and automatically chooses a recovered Rx (receive) clock source as the Tx (transmit) clock source.</p>
11	Router(config-if)# ima active-links-minimum <i>number</i>	To specify how many transmit links must be active in order for the IMA group to be operational, use this command with a number value from 1 to 8. The setting you choose depends upon your performance requirements and the total number of links in the group. If fewer than the preset minimum number are active, the group is automatically rendered inactive until the minimum number of links are up again. The default value is 1.

Step	Command	Purpose
12	Router(config-if)# ima differential-delay-maximum msec	To specify the maximum allowed differential timing delay that can exist among the active links in an IMA group, use this command by entering a milliseconds value from 25 to 200. If a link's differential delay exceeds the configured value, it stops carrying ATM-layer cells; otherwise, the IMA feature adjusts for differences in delays so that all links in a group are actively carrying network traffic. A short delay provides less tolerance in adjusting for long differential delays. However, a high value may affect overall group performance, because increased differential delay adds more latency to the traffic that is transmitted across the group.
13	Router(config-if)# ima test [link port] [pattern pattern id]	This command is typically used to troubleshoot or diagnose physical link connectivity. The IMA feature performs ongoing tests on all links in a group to verify link connectivity. The command specifies a link to use for testing and a test pattern. The pattern is sent from the specified link and looped back from the receiving end in the multiplexing-demultiplexing process. A byte in the ICP cell identifies the pattern.

Verifying IMA Group Configuration

- Step 1** Enter the privileged EXEC **show ima interface atm** [slot] /ima[group-number] [detail] command to get information about IMA group interfaces. In the examples below, important information is shown in bold. The first example shows the command output without the **detail** keyword; the second example shows the detailed information.

Note This command is unavailable in Cisco IOS Release 12.0(5)T. It is available in Release 12.0(5)XK and is planned for availability in Cisco IOS Releases 12.0(5.1)T and 12.0(7)T.

```
Router# show ima interface ATM2/IMA2
Interface ATM2/IMA2 is up
  Group index is 2
  Ne state is operational, failure status is noFailure
  active links bitmap 0x30
IMA Group Current Configuration:
  Tx/Rx configured links bitmap 0x30/0x30
  Tx/Rx minimum required links 1/1
  Maximum allowed diff delay is 25ms, Tx frame length 128
  Ne Tx clock mode CTC, configured timing reference link ATM2/4
  Test pattern procedure is disabled
IMA Group Current Counters (time elapsed 12 seconds):
  3 Ne Failures, 3 Fe Failures, 4 Unavail Secs
IMA Group Total Counters (last 0 15 minute intervals):
  0 Ne Failures, 0 Fe Failures, 0 Unavail Secs
IMA link Information:
  Link      Physical Status      NearEnd Rx Status      Test Status
  ----      -
  ATM2/4    up                          active                  disabled
  ATM2/5    up                          active                  disabled

router# show ima interface ATM2/IMA2 detail
Interface ATM2/IMA2 is up
```

```

Group index is 2
Ne state is operational, failure status is noFailure
active links bitmap 0x30
IMA Group Current Configuration:
Tx/Rx configured links bitmap 0x30/0x30
Tx/Rx minimum required links 1/1
Maximum allowed diff delay is 25ms, Tx frame length 128
Ne Tx clock mode CTC, configured timing reference link ATM2/4
Test pattern procedure is disabled
Detailed group Information:
Tx/Rx Ima_id 0x22/0x40, symmetry symmetricOperation
Number of Tx/Rx configured links 2/2
Number of Tx/Rx active links 2/2
Fe Tx clock mode ctc, Rx frame length 128
Tx/Rx timing reference link 4/4
Maximum observed diff delay 0ms, least delayed link 5
Running seconds 32
GTSM last changed 10:14:41 UTC Wed Jun 16 1999
IMA Group Current Counters (time elapsed 33 seconds):
  3 Ne Failures, 3 Fe Failures, 4 Unavail Secs
IMA Group Total Counters (last 0 15 minute intervals):
  0 Ne Failures, 0 Fe Failures, 0 Unavail Secs
Detailed IMA link Information:

Interface ATM2/4 is up
  ifIndex 13, Group Index 2, Row Status is active
  Tx/Rx Lid 4/4, relative delay 0ms
  Ne Tx/Rx state active/active
  Fe Tx/Rx state active/active
  Ne Rx failure status is noFailure
  Fe Rx failure status is noFailure
  Rx test pattern 0x41, test procedure disabled
IMA Link Current Counters (time elapsed 35 seconds):
  1 Ima Violations, 0 Oif Anomalies
  1 Ne Severely Err Secs, 2 Fe Severely Err Secs
  0 Ne Unavail Secs, 0 Fe Unavail Secs
  2 Ne Tx Unusable Secs, 2 Ne Rx Unusable Secs
  0 Fe Tx Unusable Secs, 2 Fe Rx Unusable Secs
  0 Ne Tx Failures, 0 Ne Rx Failures
  0 Fe Tx Failures, 0 Fe Rx Failures
IMA Link Total Counters (last 0 15 minute intervals):
  0 Ima Violations, 0 Oif Anomalies
  0 Ne Severely Err Secs, 0 Fe Severely Err Secs
  0 Ne Unavail Secs, 0 Fe Unavail Secs
  0 Ne Tx Unusable Secs, 0 Ne Rx Unusable Secs
  0 Fe Tx Unusable Secs, 0 Fe Rx Unusable Secs
  0 Ne Tx Failures, 0 Ne Rx Failures
  0 Fe Tx Failures, 0 Fe Rx Failures

Interface ATM2/5 is up
  ifIndex 14, Group Index 2, Row Status is active
  Tx/Rx Lid 5/5, relative delay 0ms
  Ne Tx/Rx state active/active
  Fe Tx/Rx state active/active
  Ne Rx failure status is noFailure
  Fe Rx failure status is noFailure
  Rx test pattern 0x41, test procedure disabled
IMA Link Current Counters (time elapsed 46 seconds):
  1 Ima Violations, 0 Oif Anomalies
  1 Ne Severely Err Secs, 2 Fe Severely Err Secs
  0 Ne Unavail Secs, 0 Fe Unavail Secs
  2 Ne Tx Unusable Secs, 2 Ne Rx Unusable Secs
  0 Fe Tx Unusable Secs, 2 Fe Rx Unusable Secs
  0 Ne Tx Failures, 0 Ne Rx Failures
  0 Fe Tx Failures, 0 Fe Rx Failures

```

```

IMA Link Total Counters (last 0 15 minute intervals):
  0 Ima Violations, 0 Oif Anomalies
  0 Ne Severely Err Secs, 0 Fe Severely Err Secs
  0 Ne Unavail Secs, 0 Fe Unavail Secs
  0 Ne Tx Unusable Secs, 0 Ne Rx Unusable Secs
  0 Fe Tx Unusable Secs, 0 Fe Rx Unusable Secs
  0 Ne Tx Failures, 0 Ne Rx Failures
  0 Fe Tx Failures, 0 Fe Rx Failures
    
```

Step 2 To review physical level information about the IMA group, enter the **show controllers atm** [*slot/ima group-number*] command, as shown in the following example:

```

router# show controller atm0/ima3
Interface ATM0/IMA3 is up
  Hardware is ATM IMA
  LANE client MAC address is 0050.0f0c.148b
  hwidb=0x61C2E990, ds=0x617D498C
  slot 0, unit 3, subunit 3
  rs8234 base 0x3C000000, slave base 0x3C000000
  rs8234 ds 0x617D498C
  SBDs - avail 2048, guaranteed 3, unguaranteed 2045, starved 0
  Seg VCC table 3C00B800, Shadow Seg VCC Table 617EF76C, VCD Table 61805798
  Schedule table 3C016800, Shadow Schedule table 618087C4, Size 63D
  RSM VCC Table 3C02ED80, Shadow RSM VCC Table 6180C994
  VPI Index Table 3C02C300, VCI Index Table 3C02E980
  Bucket2 Table 3C01E500, Shadow Bucket2 Table 6180A0E4
  MCR Limit Table 3C01E900, Shadow MCR Table 617D2160
  ABR template 3C01EB00, Shadow template 614DEEAC
  RM Cell RS Queue 3C02C980
  Queue          TXQ Addr  Pos  StQ Addr  Pos
  0  UBR CHN0     3C028B00  0    03118540  0
  1  UBR CHN1     3C028F00  0    03118D40  0
  2  UBR CHN2     3C029300  0    03119540  0
  3  UBR CHN3     3C029700  0    03119D40  0
  4  VBR/ABR CHN0 3C029B00  0    0311A540  0
  5  VBR/ABR CHN1 3C029F00  0    0311AD40  0
  6  VBR/ABR CHN2 3C02A300  0    0311B540  0
  7  VBR/ABR CHN3 3C02A700  0    0311BD40  0
  8  VBR-RT CHN0  3C02AB00  0    0311C540  0
  9  VBR-RT CHN1  3C02AF00  0    0311CD40  0
  10 VBR-RT CHN2  3C02B300  0    0311D540  0
  11 VBR-RT CHN3  3C02B700  0    0311DD40  0
  12 SIG          3C02BB00  0    0311E540  0
  13 VPD          3C02BF00  0    0311ED40  0

  Queue          FBQ Addr  Pos  RSQ Addr  Pos
  0  OAM          3C0EED80  255  0311F600  0
  1  UBR CHN0     3C0EFD80  0    03120600  0
  2  UBR CHN1     3C0F0D80  0    03121600  0
  3  UBR CHN2     3C0F1D80  0    03122600  0
  4  UBR CHN3     3C0F2D80  0    03123600  0
  5  VBR/ABR CHN0 3C0F3D80  0    03124600  0
  6  VBR/ABR CHN1 3C0F4D80  0    03125600  0
  7  VBR/ABR CHN2 3C0F5D80  0    03126600  0
  8  VBR/ABR CHN3 3C0F6D80  0    03127600  0
  9  VBR-RT CHN0  3C0F7D80  0    03128600  0
  10 VBR-RT CHN1  3C0F8D80  255  03129600  0
  11 VBR-RT CHN2  3C0F9D80  0    0312A600  0
  12 VBR-RT CHN3  3C0FAD80  0    0312B600  0
  13 SIG          3C0FBD80  255  0312C600  0
  SAR Scheduling channels: -1 -1 -1 -1 -1 -1 -1 -1
  ATM channel number is 1
  link members are 0x7, active links are 0x0
  Group status is blockedNe, 3 links configured,
  Group Info: Configured links bitmap 0x7, Active links bitmap 0x0,
    
```

```
Tx/Rx IMA_id 0x3/0x63,
NE Group status is startUp,
frame length 0x80, Max Diff Delay 0,
1 min links, clock mode ctc, symmetry symmetricOperation, tr1 0,
Group Failure status is startUpNe.
Test pattern procedure is disabled
SAR counter totals across all links and groups:
0 cells output, 0 cells stripped
0 cells input, 0 cells discarded, 0 AAL5 frames discarded
0 pci bus err, 0 dma fifo full err, 0 rsm parity err
0 rsm syn err, 0 rsm/seg q full err, 0 rsm overflow err
0 hs q full err, 0 no free buff q err, 0 seg underflow err
0 host seg stat q full err
```

Step 3 Enter the privileged EXEC **show atm vc** command to see how SVCs and PVCs are set up.

VCD /						Peak	Avg/Min	Burst			
Interface	Name	VPI	VCI	Type	Encaps	SC	Kbps	Kbps	Cells	Sts	
0/1	1	0	50	PVC	SNAP	UBR	1000				INAC
0/IMA3	2	0	5	PVC	SAAL	UBR	4000				UP
0/IMA3	3	0	16	PVC	ILMI	UBR	4000				UP
0/IMA3	first	1	13	PVC	MUX	VBR	640	320	80		UP
0/IMA3	4	0	34	SVC	SNAP	VBR-RT	768	768			UP

Troubleshooting Tips

To troubleshoot the ATM and IMA group configuration, enter the **ping** EXEC (user) or privileged EXEC command that checks host reachability and network connectivity. This command can confirm basic network connectivity on AppleTalk, ISO CLNS, IP, Novell, Apollo, VINES, DECnet, or XNS networks.

For IP, the **ping** command sends ICMP (Internet Control Message Protocol) Echo messages. If a station receives an ICMP Echo message, it sends an ICMP Echo Reply message back to the source.

The extended command mode of the **ping** command permits you to specify the supported IP header options, so that the router can perform a more extensive range of test options. To enter **ping** extended command mode, enter **yes** at the extended commands prompt of the **ping** command.

For detailed information on using the **ping** and extended **ping** commands, see the Cisco IOS Release 12.0 *Configuration Fundamentals Command Reference*.

If a **ping** command fails, check the following possible reasons for the connectivity problem:

- The interface is down, causing a “no ip route” error message.
- The PVC or SVC does not include proper mapping configured for the destination address, causing an “encapsulation failure” error. For more information about the VC encapsulation command, see the “Configuring IMA Groups” section on page 12 and the Cisco IOS Release 12.0 *Wide-Area Networking Command Reference*.
- If there is a firmware problem, the privileged EXEC **show controller atm [slot/port]** command shows whether an interface is able to transmit and receive cells. For sample output, see the “Verifying the ATM Interface Configuration” section on page 10.



Tips

Use the **ping** command when the network is functioning properly to see how the command works under normal conditions and so that you can compare the results when troubleshooting.

If a communication session is closing when it should not be, an end-to-end connection problem can be the cause. The **debug ip packet** command is useful for analyzing the messages traveling between the local and remote hosts. IP debugging information includes packets received, generated, and forwarded. Because the **debug ip packet** command generates a significant amount of output, use it only when traffic on the IP network is low, so other activity on the system is not adversely affected.

Monitoring and Maintaining ATM Inverse Multiplexing

Command	Purpose
Router# show ima interface atm [<i>slot</i>]/ ima [<i>group-number</i>] [detail]	Displays general or detailed information about IMA groups and the links in those groups. Note This command is unavailable in Cisco IOS Release 12.0(5)T. It is available in Release 12.0(5)XK and is planned for availability in Cisco IOS Releases 12.0(5.1)T and 12.0(7)T.
Router# show controllers [atm slot/port] Router# show controllers [atm slot/ima group-number]	Display information about current settings and performance at the physical level.

Configuration Examples

This section shows two sample configurations: one for a router that is set up for E1 ATM IMA and one for T1 ATM IMA.

E1 IMA Configuration

The following configuration example shows setup of ATM interfaces, IMA groups, PVCs, and SVCs for E1 IMA.

```
version 12.0
service timestamps debug uptime
service timestamps log uptime
no service password-encryption
!
hostname IMARouter
!
logging buffered 4096 debugging
!
ip subnet-zero
no ip domain-lookup
ip host 10.11.16.2
ip host 10.11.16.3
ip host 10.11.55.192
ip host 10.11.55.193
ip host 10.11.55.195
ip host 10.11.55.196
!
!
!
!
interface Ethernet0/0
ip address 10.17.12.100 255.255.255.192
no ip directed-broadcast
!
```

ATM interface 1/0 includes a PVC, but the specified link is not included in an IMA group. In this example, impedance and scrambling are set at their default values for E1 links and must match the far-end setting. The broadcast setting on the PVC takes precedence (addresses are fictional).

```
interface ATM1/0
 ip address 10.1.1.26 255.255.255.1
 no ip directed-broadcast
 no atm oversubscribe
 pvc 1/40
  protocol ip 10.10.10.10 broadcast
 !
 scrambling-payload
 impedance 120-ohm
 no fair-queue
 !
```

The eight-port ATM IMA E1 network module is in slot 1, and the interface commands below specify three links as members of IMA group 0.

```
interface ATM1/1
 no ip address
 no ip directed-broadcast
 no atm oversubscribe
 ima-group 0
 scrambling-payload
 impedance 120-ohm
 no fair-queue
 !
interface ATM1/2
 no ip address
 no ip directed-broadcast
 no atm oversubscribe
 ima-group 0
 scrambling-payload
 impedance 120-ohm
 no fair-queue
 !
interface ATM1/3
 no ip address
 no ip directed-broadcast
 no atm oversubscribe
 ima-group 0
 scrambling-payload
 impedance 120-ohm
 no fair-queue
 !
```

Four links are members of IMA group 1.

```
interface ATM1/4
 no ip address
 no ip directed-broadcast
 no atm oversubscribe
 ima-group 1
 scrambling-payload
 impedance 120-ohm
 no fair-queue
 !
interface ATM1/5
 no ip address
 no ip directed-broadcast
 no atm oversubscribe
 ima-group 1
 scrambling-payload
 impedance 120-ohm
 no fair-queue
```

```
!  
interface ATM1/6  
no ip address  
no ip directed-broadcast  
no atm oversubscribe  
ima-group 1  
scrambling-payload  
impedance 120-ohm  
no fair-queue  
!  
interface ATM1/7  
no ip address  
no ip directed-broadcast  
no atm oversubscribe  
ima-group 1  
scrambling-payload  
impedance 120-ohm  
no fair-queue  
!
```

The following commands specify parameters for the two IMA groups. For each group, a PVC is created and assigned an IP address.

```
interface ATM1/IMA0  
ip address 10.18.16.123 255.255.255.192  
no ip directed-broadcast  
ima clock-mode common port 2  
no atm oversubscribe  
pvc 1/42  
protocol ip 10.10.10.10 broadcast  
!  
!  
interface ATM1/IMA1  
ip address 10.19.16.123 255.255.255.192  
no ip directed-broadcast  
no atm oversubscribe  
ima active-links-minimum 3  
pvc 1/99  
protocol ip 10.10.10.10 broadcast  
!  
!  
ip classless  
ip route 0.0.0.0 0.0.0.0 10.18.16.193  
ip route 10.91.0.1 255.255.255.255 10.1.0.2  
no ip http server  
!  
!  
!  
line con 0  
exec-timeout 0 0  
history size 100  
transport input none  
line aux 0  
line vty 0 4  
exec-timeout 0 0  
password lab  
login  
history size 100  
!  
end
```

T1 IMA Configuration

The following configuration example shows setup of ATM interfaces, IMA groups, PVCs, and SVCs for T1 IMA.

```

version 12.0
service timestamps debug uptime
service timestamps log uptime
no service password-encryption
no service dhcp
!
hostname router
!
!
!
!
!
!
ip subnet-zero
!
!
!
!
!

```

There are four links in IMA group 3. The **no scrambling-payload** command is actually unnecessary, because this is the default for T1 links. The T1 automatic B8ZS line encoding is normally sufficient for proper cell delineation, so **no scrambling-payload** is the usual setting for T1 links. The scrambling setting must match the far end.

```

interface ATM0/0
no ip address
no ip directed-broadcast
no atm ilmi-keepalive
ima-group 3
no scrambling-payload
no fair-queue
!
interface ATM0/1
ip address 10.18.16.121 255.255.255.192
no ip directed-broadcast
no atm ilmi-keepalive
!
ima-group 3
no scrambling-payload
no fair-queue
!
interface ATM0/2
no ip address
no ip directed-broadcast
no atm ilmi-keepalive
ima-group 3
no scrambling-payload
no fair-queue
!
interface ATM0/3
no ip address
no ip directed-broadcast
no atm ilmi-keepalive
ima-group 3
no scrambling-payload
no fair-queue
!
!

```

IMA group 3 has PVCs that are set up for SVC management and signaling. Two SVCs and a communications PVC are also set up on the group interface.

```
interface ATM0/IMA3
  no ip address
  no ip directed-broadcast
  no atm ilmi-keepalive
  pvc 0/16 ilmi
  !
  pvc 0/5 qsaal
  !
  !
  pvc first 1/43
    vbr-rt 640 320 80
    encapsulation aal5mux ip
  !
  !
  svc second nsap 47.0091810000000050E201B101.00107B09C6ED.FE
    abr 4000 3000
  !
  !
  svc nsap 47.0091810000000002F26D4901.444444444444.01
  !
```

The IMA subcommands below specify that three links must be active in order for the group to be operational. The common clock source is the first link, ATM 0/1, and ATM 0/2 is the test link. The differential delay maximum is set to 50 milliseconds.

```
  ima active-links-minimum 3
  ima clock-mode common 1
  ima differential-delay-maximum 50
  ima test link 2
  !
interface Ethernet1/0
  no ip address
  no ip directed-broadcast
  shutdown
  !
interface Ethernet1/1
  no ip address
  no ip directed-broadcast
  shutdown
  !
ip classless
no ip http server
!
!
!
line con 0
  exec-timeout 0 0
  transport input none
line aux 0
line vty 0 4
  login
!
!
end
```

Command Reference

This section documents new or modified commands. All other commands used with this feature are documented in the Cisco IOS Release 12.0 command references.

- **cablelength long**
- **cablelength short**
- **clock source**
- **fdl**
- **ima active-links-minimum**
- **ima clock-mode**
- **ima differential-delay-maximum**
- **ima-group**
- **ima test**
- **impedance**
- **interface atm ima**
- **loopback**
- **scrambling-payload**
- **show controllers atm**
- **show ima interface atm** (available in Cisco IOS Release 12.0(5)XK and not in 12.0(5)T; planned for Cisco IOS Release 12.0(5.1)T and later releases)

In Cisco IOS Release 12.0(1)T or later, you can search and filter the output for **show** and **more** commands. This functionality is useful when you need to sort through large amounts of output, or if you want to exclude output that you do not need to see.

To use this functionality, enter a **show** or **more** command followed by the “pipe” character (`|`), one of the keywords **begin**, **include**, or **exclude**, and an expression that you want to search or filter on:

```
command | {begin | include | exclude} regular-expression
```

Following is an example of the **show atm vc** command in which you want the command output to begin with the first line where the expression “PeakRate” appears:

```
show atm vc | begin PeakRate
```

For more information on the search and filter functionality, refer to the Cisco IOS Release 12.0(1)T feature module titled *CLI String Search*.

cablelength long

To set a cable length longer than 655 feet for a DS1 link, enter the **cablelength long** interface configuration command on the interface for a T1 link. The **no** form of this command sets the cable length to the default values, **cablelength long gain26 0db**.

```
cablelength long {gain26 | gain36} {-15db | -22.5db | -7.5db | 0db}
```

```
no cablelength long
```

Syntax Description

gain26	Specifies the decibel pulse gain at 26. This is the default pulse gain.
gain36	Specifies the decibel pulse gain at 36.
-15db	Specifies the decibel pulse rate at -15 decibels.
-22.5db	Specifies the decibel pulse rate at -22.5 decibels.
-7.5db	Specifies the decibel pulse rate at -7.5 decibels.
0db	Specifies the decibel pulse rate at 0 decibels. This is the default.

Defaults

gain26 and **0db**.

Command Mode

Interface configuration

Command History

Release	Modification
11.3 MA	This command was introduced as a Cisco MC3810 controller configuration command.
12.0(5)T and 12.0(5)XK	The command was introduced as an ATM interface command on the Cisco 2600 and 3600 series.

Usage Guidelines

This command is supported on T1 long-haul links only. If you enter the **cablelength long** command on a DSX-1 (short haul) interface, the command is rejected.

The transmit attenuation value is best obtained by experimentation. If the signal received by the far-end equipment is too strong, reduce the transmit level by entering additional attenuation.

Example

On a Cisco 2600 or 3600 series router, the following example specifies a pulse gain of 36 and a decibel pulse rate of -7.5 decibels:

```
interface atm 0/2
  cablelength long gain36 -7.5db
```

Related Command

Command	Description
cablelength short	To set a cable length of 655 feet or shorter for a DS1 link, use the cablelength short interface configuration command. If no cable length is set, the system defaults to cablelength long gain26 0db .

cablelength short

To set a cable length of 655 feet or shorter for a DS1 link, enter the **cablelength short** interface configuration command. This command is supported on T1 interfaces only. The **no** form of this command deletes the **cablelength short** value and sets the default of **cablelength long gain26 0db**.

cablelength short { 133 | 266 | 399 | 533 | 655 }

no cablelength short

Syntax Description

133	Specifies a cable length from 0 to 133 feet.
266	Specifies a cable length from 134 to 266 feet.
399	Specifies a cable length from 267 to 399 feet.
533	Specifies a cable length from 400 to 533 feet.
655	Specifies a cable length from 401 to 655 feet.
0db	Specifies the decibel pulse rate at 0 decibels. This is the default.

Default

No default value or behavior

Command Mode

Interface configuration

Command History

Release	Modification
11.3 MA	This command was introduced as a Cisco MC3810 controller configuration command.
12.0(5)T and 12.0(5)XK	The command was introduced as an ATM interface command on the Cisco 2600 and 3600 series routers.

Usage Guidelines

This command is supported on T1 short-haul links only. If you enter the **cablelength short** command on a long-haul interface, the command is rejected.

Example

On a Cisco 2600 or 3600 series router, the following example specifies a cable length from 0 to 133 feet:

```
interface atm 0/2
cablelength short 133
```

Related Command

Command	Description
cablelength long	To set a cable length longer than 655 feet for a DS1 link, use the cablelength long interface configuration command. This command is supported on T1 interfaces only. If no cable length is set, the system defaults to cablelength long gain26 0db .

clock source

To configure the clock source of a DS1 link, enter the **clock source** interface configuration command. The **no** form of the command restores the default **line** setting.

clock source {**line** | **internal** | **loop-timed**}

no clock source

Syntax Description

line	Specifies that the T1/E1 link uses the recovered clock from the line.
internal	Specifies that the T1/E1 link uses the internal clock from the interface.
loop-timed	Specifies that the T1/E1 interface takes the clock from the Rx (line) and uses it for Tx.

Default

The default value is **line**.

Command Mode

Interface configuration

Command History

Release	Modification
10.3	This command was introduced.
11.1 CA	This command was modified to support the E1-G.703/G.704 serial port adapter, PA-E3 serial port adapters, and Cisco 7200 series routers..
11.3 MA	This command was introduced as a controller configuration command for the Cisco MC3810.
12.0(5)T and 12.0(5)XK	The command was introduced as an ATM interface configuration command for the Cisco 2600 and 2600 series.

Usage Guidelines

This command sets clocking for individual T1/E1 links.

Make sure that you specify the clock source correctly for each link, even if you are planning to specify that a certain link will provide clocking for all the links in an IMA group. Because links may be taken in and out of service, requiring that the system select another link for common clocking, any link in an IMA group may provide the common clock.

If the ATM interface is part of an IMA group, you can use the **loop-timed** keyword to specify that the clock source is the same as the IMA group clock source.

Example

On a Cisco 2600 or 3600 series router, the following example specifies an internal clock source for the link:

```
interface atm 0/2
  clock source internal
```

Related Command

Command	Description
ima clock-mode	To set the transmit clock mode for an ATM IMA group, execute the interface configuration command ima clock-mode . If all the links in the group share a clock source, use the common keyword. If all the links use different clock sources, use the independent clock source keyword.

fdl

To set the Facility Data Link (FDL) exchange standard for a T1 interface that uses Extended SuperFrame (ESF) framing format, enter the **fdl** interface configuration command. The **no** form of this command specifies that there is no ESF FDL.

fdl {**att** | **ansi** | **all** | **none**}

no fdl {**att** | **ansi** | **all** | **none**}

Syntax Description

att	Selects AT&T technical reference (TR) 54016 standard for ESF FDL exchange support.
ansi	Selects ANSI T1.403 for ESF FDL exchange support.
all	Selects both AT&T TR54016 and ANSI T1.403 ESF FDL exchange support.
none	Specifies that there is no support for ESF FDL exchange.

Default

The default value is **ansi**.

Command Mode

Interface configuration

Command History

Release	Modification
11.3	This command was introduced.
12.0	This command was modified in Cisco IOS Release 12.0 to add command syntax both for the Cisco MC3810.
12.0(5)T and 12.0(5)XK	The command was introduced as an ATM interface configuration command for the Cisco 2600 and 2600 series. The keyword none was added to the original controller command, and the keyword both was changed to all .

Usage Guidelines

This command is available for T1 links only and sets the standard that will be followed for FDL messaging through a 4-Kbps out-of-band channel that a service provider uses to check for errors on the facility. You must use the same FDL exchange standard as your service provider. If the setting is not correct, the link may fail to come up. You can have a different standard configured on each T1 interface.

Note When using a multiport T1 ATM IMA network module on a Cisco 2600 or 3600 series router, ESF framing and binary eight zero substitution (B8ZS) line encoding are supported. When using a multiport E1 ATM IMA network module on a Cisco 2600 or 3600 series router, CRC4 multiframe framing and HDB3 line encoding are supported. These are the parameters specified by the ATM Forum, and they cannot be changed.

Example

On a Cisco 2600 or 3600 series router, the following example specifies both ANSI and AT&T standards for FDL exchange:

```
interface atm 0/2
 fdl all
```

ima active-links-minimum

To set the minimum number of links that must be operating in order for an ATM IMA group to remain in service, execute the IMA interface configuration command **ima active-links-minimum**. The **no** form of the command removes the current configuration and sets the value to the default.

ima active-links-minimum *number*

no ima active-links-minimum *number*

Syntax Description

number Enter a value from 1 to 8.

Default

The default is one link.

Command Mode

Interface configuration

Command History

Release	Modification
12.0(5)T and 12.0(5)XK	This command was introduced.

Usage Guidelines

The minimum number of links that should be active for continued group operation depends upon the applications you are using and the speeds they require. ATM frame size and the number of links in a group affect the overhead required by ATM.

When planning, you should assume that only the bandwidth supplied by the minimal number of links will be available. If you decrease the value set in this command, make sure that virtual circuits of a higher bandwidth than the minimum supported by the command are torn down as necessary.

Example

On a Cisco 2660 or 3600 series router, the following example specifies that two links in IMA group 2 must be operational in order for the group to remain in service:

```
interface atm 0/ima2
  ima active-links-minimum 2
```

ima clock-mode

To set the transmit clock mode for an ATM IMA group, execute the IMA interface configuration command **ima clock-mode**. If all the links in the group share a clock source, use the **common** keyword. If all the links use different clock sources, use the **independent** clock source keyword. The **no** form of the command removes the current configuration.

```
ima clock-mode { common port | independent }
```

```
no ima clock-mode
```

Syntax Description

common	The transmit clocks for all the links in the group are derived from the same source.
<i>port</i>	When you choose a common clock source, also specify the link that will provide clocking for the IMA group, which is called the common link. If the common link fails, the system automatically chooses one of the remaining active links to provide clocking.
independent	The transmit clock source for at least one link in the IMA group is different from the clock source used by the other links.

Default

The default value is **common**. If no port is specified, the system automatically chooses an active link to provide clocking.

Command Mode

Interface configuration

Command History

Release	Modification
12.0(5)T and 12.0(5)XK	This command was introduced.

Usage Guidelines

This command controls the clock for the IMA group as a whole. When the **independent** keyword is set, the **clock source** ATM interface configuration command is used under each interface to determine clocking individually. When the **common** keyword is set, the **clock source** ATM interface configuration command for the common link determines clocking for all the links in the group.

Because the system automatically chooses a replacement for the common link when it fails, any link in an IMA group potentially can provide the recovered transmit clock. For this reason, even when the common keyword is set with a specific link stipulated by the port value, you should use the ATM interface configuration **clock source** command to make sure that the clock source is configured correctly on each interface in the IMA group.

Example

On a Cisco 2600 or 3600 series router, the following example specifies that the links in IMA group 2 use a common clock source on link 0:

```
interface atm0/ima2
  ima clock-mode common 0
```

Related Commands

Command	Description
clock source	This ATM interface configuration command sets the clock source for a link.
show ima interface atm	This command shows clock source information about an IMA group as a whole and about the links included in it.

ima differential-delay-maximum

To specify the maximum allowed differential timing delay that can exist among the active links in an IMA group, enter the **ima differential-delay-maximum** IMA interface configuration command. If a link delay exceeds the specified maximum, the link is dropped; otherwise, the IMA feature adjusts for differences in delays so that all links in a group are aligned and carry ATM-layer traffic. The **no** form of the command restores the default setting.

ima differential-delay-maximum *msec*

no ima differential-delay-maximum *msec*

Syntax Description

msec Specify a value from 25 to 200 to define the differential delay in milliseconds.

Default

The default value is 25 ms.

Command Mode

Interface configuration

Command History

Release	Modification
12.0(5)T and 12.0(5)XK	This command was introduced.

Usage Guidelines

This command helps control latency in ATM-layer traffic by setting a limit on how much latency the slowest link in the group is allowed to introduce (a slower link has a longer propagation delay—for example, due to a longer path through the network or less accurate physical layer clocking—than other links). Setting a high value allows a slow link to continue operating as part of the group, although such a setting means there is added delay to links across the group. A low setting may result in less latency for traffic across the group than a high setting, but it can mean that the system takes a slow link out of operation, reducing total bandwidth.

When a link has been removed from service, it is automatically placed back in service when it meets the delay differential standard.

Example

On a Cisco 2600 or 3600 series router, the following example specifies that the links in IMA group 2 have a maximum differential delay of 50 ms:

```
interface atm0/ima2
  ima differential-delay-maximum 50
```

Related Command

Command	Description
show ima interface atm	This command shows differential delay information about an IMA group.

ima-group

To define physical linkd as IMA group members, execute the **ima-group** configuration command for each group member. When you first perform the configuration or when you change the group number, the interface is automatically disabled, moved to the new group, and then enabled. The **no** form of the command removes the port from the group.

ima-group *group-number*

no ima-group *group-number*

Syntax Description

group-number Enter an IMA group number from 0 to 3. IMA groups can span multiple ports on a network module but cannot span network modules.

Default

By default, physical links are not included in IMA groups.

Command Mode

Interface configuration

Command History

Release	Modification
12.0(5)T and 12.0(5)XK	This command was introduced.

Example

On a Cisco 2600 or 3600 series router, the following example makes interface 1 on the ATM module in slot 0 a member of IMA group 2:

```
interface atm0/1
  ima-group 2
```

Related Commands

Command	Description
interface atm	Configures physical links for ATM.
interface atm ima	Configures an ATM IMA group that you can set various parameters for the group as a whole.
show ima interface atm	Shows information about the links that are included in an IMA group.
shutdown	Disables or enables (no form) the interface without deleting the configuration.

ima test

To specify an interface and a test pattern, execute the **ima test** IMA configuration command. To verify link and group connectivity, the pattern is sent from the specified link and looped back from the receiving end across all links belonging to the group as defined at the remote end. This can help troubleshoot physical link connectivity or configuration problems at the remote end. The local end verifies that the pattern is returned on all links belonging to the group at the local end, and testing is continuous. An ICP cell in each frame identifies the pattern. The **no** form of the command stops the test.

ima test [**link** *port*] [**pattern** *pattern-id*]

no ima test [**link** *port*] [**pattern** *pattern-id*]

Syntax Description

<i>port</i>	(Optional) The identifier for the interface (as in <i>slot/port</i>) where the physical link is located.
<i>pattern-id</i>	(Optional) A value from 0 to 254, set in hexadecimal or decimal numbers, identifies a pattern to be sent to the far end of the link.

Defaults

There is no default for the *port* value. The default value for *pattern-id* is 106 (0x6A).

Command Mode

Interface configuration

Command History

Release	Modification
12.0(5)T and 12.0(5)XK	This command was introduced.

Command Usage

When a link is not transmitting or receiving a pattern correctly, the command reports the link number where the problem exists.

Example

On a Cisco 2600 or 3600 series router, the following example configures link 4 to send test pattern 56.

```
interface atm 0/ima 2
  ima test link 2 pattern 56
```

Related Command

Command	Description
show ima interface atm	Shows the currently configured test link and test pattern for an IMA group.

impedance

To specify the impedance (amount of wire resistance and reactivity to current) for an E1 link, enter the **impedance** interface configuration command. The setting must match the physical wiring. The **no** form of the command sets the default of **120-ohm**.

```
impedance {75-ohm | 120-ohm}  
no impedance {75-ohm | 120-ohm}
```

Syntax Description

120-ohm	Matches the unbalanced twisted-pair 120-ohm interface.
75-ohm	Matches the balanced BNC 750-ohm interface.

Default

120-ohm

Command Mode

Interface configuration

Command History

Release	Modification
11.3(1)T	This command was introduced as a voice-port configuration command.
12.0(5)T and 12.0(5)XK	This command was introduced as an interface configuration command for Cisco 2600 and 3600 series routers.

Command Usage

Impedance levels are maintained to avoid data corruption due to attenuation over long-distance links. The impedance is determined by the dongle-type cable that you plug in to the IMA module. Set this command to match that cable.

Example

On a Cisco 2600 or 3600 series router, the following example configures impedance at 120-ohm on ATM interface 0/2.

```
interface atm 0/2  
  impedance 120-ohm
```

interface atm ima

To configure an ATM IMA group and enter interface configuration mode, enter the **interface atm ima** global configuration command. If the group does not exist when the command is issued, the command automatically creates the group. The **no** form of the command removes the IMA group from the specified interface and removes all configurations and connections for the IMA group.

interface atm *slot/imagroup-number*

no interface atm *slot/imagroup-number*

Syntax Description

<i>slot</i>	This setting specifies the slot location of the ATM IMA network module. The values range from 0 to 3 depending on the router.
<i>group-number</i>	Enter an IMA group number from 0 to 3. You can create up to four groups. Do not include a space before the group number.

Default

By default there are no IMA groups, only individual ATM links.

Command Mode

Global configuration

Command History

Release	Modification
12.0(5)T and 12.0(5)XK	This command was introduced.

Usage Guidelines

When a port is configured for IMA functionality, it no longer operates as an individual ATM link.

Specifying ATM links as members of a group by using the **ima group** interface command does not enable the group. You must use the **interface atm ima** command to create the group.

Example

On a Cisco 2600 or 3600 series router, the following example configures IMA group 0 on the module in slot 1:

```
interface atm 1/ima0
 ip address 10.17.12.100
```

Related Commands

Command	Description
ima-group	Configures the physical links as IMA group members; execute this interface configuration command for each physical link that you include in an IMA group.
interface atm	Configures physical links for ATM.
show ima interface atm	Displays general and detailed information about IMA groups and the links they include.
shutdown	Disables or enables (no form) the interface without deleting the configuration.

loopback

To loop packets back to the interface for testing, enter the **loopback** interface configuration command with or without an optional keyword. The **no** form of the command removes the loopback.

loopback [**line** | **local** | **payload** | **remote**]

no loopback [**line** | **local** | **payload** | **remote**]

Syntax Description

line	Places the interface into external loopback mode at the line.
local	Places the interface into local loopback mode.
payload	Places the interface into external loopback mode at the payload level.
remote	Keeps the local end of the connection in remote loopback mode.

Default

The default keyword is **line**.

Command Mode

Interface configuration

Command History

Release	Modification
10.0	This command was introduced as an interface configuration command.
11.3 MA	This command was modified as an interface configuration command for the Cisco MC3810.
12.0(5)T and 12.0(5)XK	The command was modified as an ATM interface configuration command for the Cisco 2600 and 3600 series routers.

Usage Guidelines

You can use a loopback test on lines to detect and distinguish equipment malfunctions caused either by line and Channel Service Unit/Digital Service Unit (CSU/DSU) or by the interface. If correct data transmission is not possible when an interface is in loopback mode, the interface is the source of the problem.

The local loopback does not generate any packets automatically. Instead, the **ping** command is used.

Example

On a Cisco 2600 or 3600 series router, the following example sets up local loopback diagnostics:

```
interface atm 1/0
 loopback local
```

scrambling-payload

Scrambling improves data reliability by randomizing the ATM cell payload frames to avoid continuous non-variable bit patterns and improve the efficiency of ATM's cell delineation algorithms. The **no** form disables scrambling.

scrambling-payload

no scrambling-payload

Syntax Description

This command has no arguments or keywords.

Defaults

By default, payload scrambling is on for E1 links and off for T1 links.

Command Mode

Interface configuration

Command History

Release	Modification
12.0(5)T and 12.0(5)XK	This command was introduced.

Usage Guidelines

Normally, you do not issue the **scrambling-payload** command explicitly, because the default value is sufficient. On T1 links, the default B8ZS line encoding normally assures sufficient reliability.

The scrambling setting must match that of the far end.

Example

On a Cisco 2600 or 3600 series router, the following example sets the link on interface 1 on the module in slot 0 to no scrambling:

```
interface atm0/1
 no scrambling-payload
```

show controllers atm

Enter the privileged EXEC **show controllers atm** command, using a form that specifies the Inverse Multiplexing over ATM (IMA) group number to see information about an IMA group.

show controllers atm [*slot/ima group-number*]

Syntax Description

<i>slot</i>	[Optional] This setting specifies the slot location of the ATM IMA network module. The values range from 0 to 3 depending on the router.
ima	[Optional] This keyword indicates an IMA group specification rather than a port value for a UNI interface.
<i>group-number</i>	[Optional] Enter an IMA group number from 0 to 3. If you specify the group number, do not insert a space between ima and the number.

Default

No default behavior or values.

Command History

Release	Modification
Release 11.2 GS	This command was added to support the Cisco 12000 series Gigabit Switch Routers.
12.0(5)T and 12.0(5)XK	This command was modified to support IMA groups.

Usage Guidelines

Use this command to monitor and diagnose ATM IMA links and groups.

Example

On a Cisco 2600 or 3600 series router, the following example displays detailed information about IMA group 0 on ATM interface 2.

```
router# show controller atm0/ima3
Interface ATM0/IMA3 is up
Hardware is ATM IMA
LANE client MAC address is 0050.0f0c.148b
hwidb=0x61C2E990, ds=0x617D498C
slot 0, unit 3, subunit 3
rs8234 base 0x3C000000, slave base 0x3C000000
rs8234 ds 0x617D498C
SBDs - avail 2048, guaranteed 3, unguaranteed 2045, starved 0
Seg VCC table 3C00B800, Shadow Seg VCC Table 617EF76C, VCD Table 61805798
Schedule table 3C016800, Shadow Schedule table 618087C4, Size 63D
RSM VCC Table 3C02ED80, Shadow RSM VCC Table 6180C994
VPI Index Table 3C02C300, VCI Index Table 3C02E980
Bucket2 Table 3C01E500, Shadow Bucket2 Table 6180A0E4
MCR Limit Table 3C01E900, Shadow MCR Table 617D2160
ABR template 3C01EB00, Shadow template 614DEEAC
RM Cell RS Queue 3C02C980
```

show controllers atm

Queue	TXQ Addr	Pos	StQ Addr	Pos
0 UBR CHN0	3C028B00	0	03118540	0
1 UBR CHN1	3C028F00	0	03118D40	0
2 UBR CHN2	3C029300	0	03119540	0
3 UBR CHN3	3C029700	0	03119D40	0
4 VBR/ABR CHN0	3C029B00	0	0311A540	0
5 VBR/ABR CHN1	3C029F00	0	0311AD40	0
6 VBR/ABR CHN2	3C02A300	0	0311B540	0
7 VBR/ABR CHN3	3C02A700	0	0311BD40	0
8 VBR-RT CHN0	3C02AB00	0	0311C540	0
9 VBR-RT CHN1	3C02AF00	0	0311CD40	0
10 VBR-RT CHN2	3C02B300	0	0311D540	0
11 VBR-RT CHN3	3C02B700	0	0311DD40	0
12 SIG	3C02BB00	0	0311E540	0
13 VPD	3C02BF00	0	0311ED40	0

Queue	FBQ Addr	Pos	RSQ Addr	Pos
0 OAM	3C0EED80	255	0311F600	0
1 UBR CHN0	3C0EFD80	0	03120600	0
2 UBR CHN1	3C0F0D80	0	03121600	0
3 UBR CHN2	3C0F1D80	0	03122600	0
4 UBR CHN3	3C0F2D80	0	03123600	0
5 VBR/ABR CHN0	3C0F3D80	0	03124600	0
6 VBR/ABR CHN1	3C0F4D80	0	03125600	0
7 VBR/ABR CHN2	3C0F5D80	0	03126600	0
8 VBR/ABR CHN3	3C0F6D80	0	03127600	0
9 VBR-RT CHN0	3C0F7D80	0	03128600	0
10 VBR-RT CHN1	3C0F8D80	255	03129600	0
11 VBR-RT CHN2	3C0F9D80	0	0312A600	0
12 VBR-RT CHN3	3C0FAD80	0	0312B600	0
13 SIG	3C0FBD80	255	0312C600	0

SAR Scheduling channels: -1 -1 -1 -1 -1 -1 -1 -1

ATM channel number is 1

link members are 0x7, active links are 0x0

Group status is blockedNe, 3 links configured,

Group Info: Configured links bitmap 0x7, Active links bitmap 0x0,

Tx/Rx IMA_id 0x3/0x63,

NE Group status is startUp,

frame length 0x80, Max Diff Delay 0,

1 min links, clock mode ctc, symmetry symmetricOperation, trl 0,

Group Failure status is startUpNe.

Test pattern procedure is disabled

SAR counter totals across all links and groups:

0 cells output, 0 cells stripped

0 cells input, 0 cells discarded, 0 AAL5 frames discarded

0 pci bus err, 0 dma fifo full err, 0 rsm parity err

0 rsm syn err, 0 rsm/seg q full err, 0 rsm overflow err

0 hs q full err, 0 no free buff q err, 0 seg underflow err

0 host seg stat q full err

Related Commands

Command	Description
show ima interface atm	Displays general and detailed information about IMA groups and the links they include. Some of the information is similar to what appears in the show controllers atm command output, but in decimal rather than hexadecimal format.
show controllers atm	This form of the command displays details about the physical interface.

show ima interface atm

The **show ima interface atm** command provides information about all configured IMA groups or a specific group.

show ima interface atm [*slot*] /**ima**[*group-number*] [**detail**]

Note This command is unavailable in Cisco IOS Release 12.0(5)T. It is available in Release 12.0(5)XK and is planned for availability in Cisco IOS Releases 12.0(5.1)T and 12.0(7)T.

Syntax Description

<i>slot</i>	[Optional] This setting specifies the slot location of the ATM IMA network module. The values range from 0 to 3 depending on the router.
<i>group-number</i>	[Optional] Enter an IMA group number from 0 to 3. If you specify the group number, do not insert a space between ima and the number.
detail	[Optional] To obtain detailed information, use this keyword.

Default

No default behavior or values.

Command History

Release	Modification
12.0(5)XK	This command was introduced.

Usage Guidelines

Use this command to monitor the status of IMA group links.

Example

On a Cisco 2600 or 3600 series router, the following example displays detailed information about IMA group 0 on ATM interface 2. Without the **detail** keyword, only the information up to “Detailed group Information:” appears.

```
Router# show ima interface atm 4/ima0 detail
Interface ATM2/IMA2 is up
  Group index is 2
  Ne state is operational, failure status is noFailure
  active links bitmap 0x30
  IMA Group Current Configuration:
  Tx/Rx configured links bitmap 0x30/0x30
  Tx/Rx minimum required links 1/1
  Maximum allowed diff delay is 25ms, Tx frame length 128
  Ne Tx clock mode CTC, configured timing reference link ATM2/4
  Test pattern procedure is disabled
  Detailed group Information:
  Tx/Rx Ima_id 0x22/0x40, symmetry symmetricOperation
  Number of Tx/Rx configured links 2/2
  Number of Tx/Rx active links 2/2
```

show ima interface atm

```
Fe Tx clock mode ctc, Rx frame length 128
Tx/Rx timing reference link 4/4
Maximum observed diff delay 0ms, least delayed link 5
Running seconds 32
GTSM last changed 10:14:41 UTC Wed Jun 16 1999
IMA Group Current Counters (time elapsed 33 seconds):
 3 Ne Failures, 3 Fe Failures, 4 Unavail Secs
IMA Group Total Counters (last 0 15 minute intervals):
 0 Ne Failures, 0 Fe Failures, 0 Unavail Secs
Detailed IMA link Information:
```

```
Interface ATM2/4 is up
  ifIndex 13, Group Index 2, Row Status is active
  Tx/Rx Lid 4/4, relative delay 0ms
  Ne Tx/Rx state active/active
  Fe Tx/Rx state active/active
  Ne Rx failure status is noFailure
  Fe Rx failure status is noFailure
  Rx test pattern 0x41, test procedure disabled
IMA Link Current Counters (time elapsed 35 seconds):
 1 Ima Violations, 0 Oif Anomalies
 1 Ne Severely Err Secs, 2 Fe Severely Err Secs
 0 Ne Unavail Secs, 0 Fe Unavail Secs
 2 Ne Tx Unusable Secs, 2 Ne Rx Unusable Secs
 0 Fe Tx Unusable Secs, 2 Fe Rx Unusable Secs
 0 Ne Tx Failures, 0 Ne Rx Failures
 0 Fe Tx Failures, 0 Fe Rx Failures
IMA Link Total Counters (last 0 15 minute intervals):
 0 Ima Violations, 0 Oif Anomalies
 0 Ne Severely Err Secs, 0 Fe Severely Err Secs
 0 Ne Unavail Secs, 0 Fe Unavail Secs
 0 Ne Tx Unusable Secs, 0 Ne Rx Unusable Secs
 0 Fe Tx Unusable Secs, 0 Fe Rx Unusable Secs
 0 Ne Tx Failures, 0 Ne Rx Failures
 0 Fe Tx Failures, 0 Fe Rx Failures
```

```
Interface ATM2/5 is up
  ifIndex 14, Group Index 2, Row Status is active
  Tx/Rx Lid 5/5, relative delay 0ms
  Ne Tx/Rx state active/active
  Fe Tx/Rx state active/active
  Ne Rx failure status is noFailure
  Fe Rx failure status is noFailure
  Rx test pattern 0x41, test procedure disabled
IMA Link Current Counters (time elapsed 46 seconds):
 1 Ima Violations, 0 Oif Anomalies
 1 Ne Severely Err Secs, 2 Fe Severely Err Secs
 0 Ne Unavail Secs, 0 Fe Unavail Secs
 2 Ne Tx Unusable Secs, 2 Ne Rx Unusable Secs
 0 Fe Tx Unusable Secs, 2 Fe Rx Unusable Secs
 0 Ne Tx Failures, 0 Ne Rx Failures
 0 Fe Tx Failures, 0 Fe Rx Failures
IMA Link Total Counters (last 0 15 minute intervals):
 0 Ima Violations, 0 Oif Anomalies
 0 Ne Severely Err Secs, 0 Fe Severely Err Secs
 0 Ne Unavail Secs, 0 Fe Unavail Secs
 0 Ne Tx Unusable Secs, 0 Ne Rx Unusable Secs
 0 Fe Tx Unusable Secs, 0 Fe Rx Unusable Secs
 0 Ne Tx Failures, 0 Ne Rx Failures
 0 Fe Tx Failures, 0 Fe Rx Failures
```

Related Command

Command	Description
show controllers atm	Displays detailed information about IMA groups and the links they include, as well as about current queues and ATM QoS settings.

Debug Command

This section documents a new **debug** command, **debug ima**.

debug ima

To display debug messages for IMA groups and links, enter the **debug ima** privileged EXEC command. Enter the **no** form of this command to disable debugging output.

[no] debug ima

Syntax Description

This command has no arguments or keywords.

Default

Debugging for IMA groups is not enabled.

Command History

Release	Modification
12.0(5)T and 12.0(5)XK	This command was introduced.

Example

The following example shows output when you enter the **debug ima** command while adding two ATM links to an IMA group. Notice that the group has not yet been created with the **interface atm slot/imagroup-number** command, so the links are not activated yet as group members. However, the individual ATM links are deactivated.

```
Router# debug ima
IMA network interface debugging is on
Router# config terminal
Enter configuration commands, one per line. End with CNTL/Z.
Router(config)# interface atm1/0
Router(config-if)# ima-group 1
Router(config-if)#
01:35:08:IMA shutdown atm layer of link ATM1/0
01:35:08:ima_clear_atm_layer_if ATM1/0
01:35:08:IMA link ATM1/0 removed in firmware
01:35:08:ima_release_channel:ATM1/0 released channel 0.
01:35:08:Bring up ATM1/4 that had been waiting for a free channel.
01:35:08:IMA:no shut the ATM interface.
01:35:08:IMA allocate_channel:ATM1/4 using channel 0.
01:35:08:IMA config_restart ATM1/4
01:35:08:IMA adding link 0 to Group ATM1/IMA1ATM1/0 is down waiting for IMA group 1 to
be activated
01:35:08:Link 0 was added to Group ATM1/IMA1
01:35:08:ATM1/0 is down waiting for IMA group 1 to be created.
01:35:08:IMA send AIS on link ATM1/0
01:35:08:IMA Link up/down Alarm:port 0, new status 0x10, old_status 0x1.
01:35:10:%LINK-3-UPDOWN:Interface ATM1/4, changed state to up
01:35:10:%LINK-3-UPDOWN:Interface ATM1/0, changed state to down
01:35:11:%LINEPROTO-5-UPDOWN:Line protocol on Interface ATM1/4, changed state to up
01:35:11:%LINEPROTO-5-UPDOWN:Line protocol on Interface ATM1/0, changed state to down
Router(config-if)# int atm1/1
Router(config-if)# ima-group 1
Router(config-if)#
01:37:19:IMA shutdown atm layer of link ATM1/1
01:37:19:ima_clear_atm_layer_if ATM1/1
01:37:19:IMA link ATM1/1 removed in firmware
```

```
01:37:19:ima_release_channel:ATM1/1 released channel 1.
01:37:19:Bring up ATM1/5 that had been waiting for a free channel.
01:37:19:IMA:no shut the ATM interface.
01:37:19:IMA allocate_channel:ATM1/5 using channel 1.
01:37:19:IMA config_restart ATM1/5
01:37:19:IMA adding link 1 to Group ATM1/IMA1ATM1/1 is down waiting for IMA group 1 to
be activated
01:37:19:Link 1 was added to Group ATM1/IMA1
01:37:19:ATM1/1 is down waiting for IMA group 1 to be created.
01:37:19:IMA send AIS on link ATM1/1
01:37:19:IMA Link up/down Alarm:port 1, new status 0x10, old_status 0x1.
Router(config-if)#
01:37:21:%LINK-3-UPDOWN:Interface ATM1/5, changed state to up
01:37:21:%LINK-3-UPDOWN:Interface ATM1/1, changed state to down
01:37:22:%LINEPROTO-5-UPDOWN:Line protocol on Interface ATM1/5, changed state to up
01:37:22:%LINEPROTO-5-UPDOWN:Line protocol on Interface ATM1/1, changed state to down
```

Related Commands

Command	Description
debug atm errors	Displays debug messages for ATM errors. Reports specific problems such as encapsulation errors and errors related to operation, administration, and maintenance (OAM) cells.
debug atm events	Displays debug messages for ATM events. Reports specific events such as PVC setup completion, changes in carrier states, and interface rates.

Glossary

AAL—ATM Adaptation Layer. Service-dependent sublayer of the data link layer. The AAL accepts data from different applications and presents it to the ATM layer in the form of 48-byte ATM payload segments. AALs consist of two sublayers: convergence sublayer (CS) and segmentation and reassembly (SAR). AALs differ on the basis of the source-destination timing used, whether they use constant bit rate (CBR) or variable bit rate (VBR), and whether they are used for connection-oriented or connectionless mode data transfer. At present, the four types of AAL recommended by the ITU-T are AAL1, AAL2, AAL3/4, and AAL5.

AAL1—ATM adaptation layer 1. One of four AALs recommended by the ITU-T. AAL1 is used for connection-oriented, delay-sensitive services requiring constant bit rates, such as uncompressed video and other isochronous traffic.

AAL5—ATM adaptation layer 5. One of four AALs recommended by the ITU-T. AAL5 supports connection-oriented VBR services and is used predominantly for the transfer of classical IP over ATM and LANE traffic. AAL5 uses simple and efficient AAL (SEAL) and is the least complex of the current AAL recommendations. It offers low bandwidth overhead and simpler processing requirements in exchange for reduced bandwidth capacity and error-recovery capability.

ABR—available bit rate. QoS class defined by the ATM Forum for ATM networks. ABR is used for connections that do not require timing relationships between source and destination. ABR provides no guarantees in terms of cell loss or delay, providing only best-effort service. Traffic sources adjust their transmission rate in response to information they receive describing the status of the network and its capability to successfully deliver data.

AIS—alarm indication signal. In a T1 transmission, an all-ones signal transmitted in lieu of the normal signal to maintain transmission continuity and to indicate to the receiving terminal that there is a transmission fault that is located either at, or upstream from, the transmitting terminal.

ATM—Asynchronous Transfer Mode. International standard for cell relay in which multiple service types (such as voice, video, or data) are conveyed in fixed-length (53-byte) cells. Fixed-length cells allow cell processing to occur in hardware, thereby reducing transit delays. ATM is designed to take advantage of high-speed transmission media such as E3, SONET, and T3.

B8ZS—binary 8-zero substitution. Line-code type, used on T1 and E1 circuits, in which a special code is substituted whenever 8 consecutive zeros are sent over the link. This code is then interpreted at the remote end of the connection. This technique guarantees ones density independent of the data stream.

CBR—constant bit rate. QoS class defined by the ATM Forum for ATM networks. CBR is used for connections that depend on precise clocking to ensure undistorted delivery.

CPCS—common part convergence sublayer. One of the two sublayers of any AAL. The CPCS is service-independent and is further divided into the CS and the SAR sublayers. The CPCS is responsible for preparing data for transport across the ATM network, including the creation of the 48-byte payload cells that are passed to the ATM layer.

CS—convergence sublayer. One of the two sublayers of the AAL common part convergence sublayer (CPCS), which is responsible for padding and error checking. PDUs passed from the service specific convergence sublayer (SSCS) are appended with an 8-byte trailer (for error checking and other control information) and padded, if necessary, so that the length of the resulting PDU is divisible by 48. These PDUs are then passed to the SAR sublayer of the CPCS for further processing.

E1—European digital carrier facility used for transmitting data through the telephone hierarchy. The transmission rate for E1 is 2.048 megabits per second (Mbps).

E3—Wide-area digital transmission scheme used predominantly in Europe that carries data at a rate of 34.368 Mbps. E3 lines can be leased for private use from common carriers.

ESF—Extended Superframe. Framing type used on T1 circuits that consists of 24 frames of 192 bits each, with the 193rd bit providing timing and other functions. ESF is an enhanced version of SF.

FDL—Facility Data Link. A 4-Kbps channel, provided by the Extended SuperFrame (ESF) T1 framing format. The FDL performs outside the payload capacity and allows a service provider to check error statistics on terminating equipment, without intrusion.

ICP—IMA control protocol

ICMP—Internet Control Message Protocol. Network layer Internet protocol that reports errors and provides other information relevant to IP packet processing. Documented in RFC 792.

ILMI—Interim Local Management Interface. Specification developed by the ATM Forum for incorporating network-management capabilities into the ATM User-Network Interface (UNI).

IMA—Inverse Multiplexing for ATM, a standard protocol defined by the ATM Forum in 1997.

IMA group—Physical links grouped to form a higher-bandwidth logical link whose rate is approximately the sum of the individual link rates.

ISDN—Integrated Services Digital Network. Communication protocol, offered by telephone companies, that permits telephone networks to carry data, voice, and other source traffic.

NM—Network module.

OAM cell—Operation, Administration, and Maintenance cell. ATM Forum specification for cells used to monitor virtual circuits. OAM cells provide a virtual circuit-level loopback in which a router responds to the cells, demonstrating that the circuit is up, and the router is operational.

PDU—protocol data unit.

POTS—Plain Old Telephone Service. Basic telephone service supplying standard single-line telephones, telephone lines, and access to the public switched telephone network.

PVC—permanent virtual circuit. Virtual circuit that is permanently established. PVCs save bandwidth associated with circuit establishment and tear down in situations where certain virtual circuits must exist all the time. In ATM terminology, called a permanent virtual connection.

QoS—quality of service. Measure of performance for a transmission system that reflects its transmission quality and service availability.

SAR—segmentation and reassembly. One of the two sublayers of the AAL CPCS, responsible for dividing (at the source) and reassembling (at the destination) the PDUs passed from the CS. The SAR sublayer takes the PDUs processed by the CS and, after dividing them into 48-byte pieces of payload data, passes them to the ATM layer for further processing.

SF—Super Frame. Common framing type used on T1 circuits. SF consists of 12 frames of 192 bits each, with the 193rd bit providing error checking and other functions. SF is superseded by ESF, but is still widely used. Also called D4 framing.

SONET—Synchronous Optical Network. High-speed (up to 2.5 Gbps) synchronous network specification developed by Bellcore and designed to run on optical fiber. STS-1 is the basic building block of SONET.

SSCS—service specific convergence sublayer. One of the two sublayers of any AAL. SSCS, which is service dependent, offers assured data transmission. The SSCS can be null as well, in classical IP over ATM or LAN emulation implementations.

SVC—switched virtual circuit. Virtual circuit that is dynamically established on demand and is torn down when transmission is complete. SVCs are used in situations where data transmission is sporadic. Called a switched virtual connection in ATM terminology.

T3—Digital WAN carrier facility. T3 transmits DS-3-formatted data at 44.736 Mbps through the telephone switching network.

UBR—unspecified bit rate. Quality of Service (QoS) class defined by the ATM Forum for ATM networks. UBR allows any amount of data up to a specified maximum to be sent across the network, but there are no guarantees in terms of cell loss rate and delay.

UNI—User-Network Interface. ATM Forum specification that defines an interoperability standard for the interface between ATM-based products (a router or an ATM switch) located in a private network and the ATM switches located within the public carrier networks. Also used to describe similar connections in Frame Relay networks.

VBR—variable bit rate. QoS class defined by the ATM Forum for ATM networks. VBR is subdivided into a real time (RT) class and non-real time (NRT) class. VBR (RT) is used for connections in which there is a fixed timing relationship between samples. VBR (NRT) is used for connections in which there is no fixed timing relationship between samples, but that still need a guaranteed QoS.

VC—virtual circuit. Logical circuit created to ensure reliable communication between two network devices. A virtual circuit is defined by a VPI/VCI pair, and can be either permanent (PVC) or switched (SVC). Virtual circuits are used in Frame Relay and X.25. In ATM, a virtual circuit is called a virtual channel.