

Configuring ATM on the NPM for Cisco 4500 and 4700 Routers

This chapter describes how to configure ATM on the Cisco 4500 and 4700 routers that have the ATM Network Processor Module (NPM).

For a complete description of the ATM commands in this chapter, refer to the “ATM Commands” chapter of the *Wide-Area Networking Command Reference*. To locate documentation of other commands that appear in this chapter, use the command reference master index or search online.

For information about configuring LAN emulation (LANE) for ATM, refer to the “Configuring LAN Emulation” chapter in the *Cisco IOS Switching Services Configuration Guide*. For information about LANE commands, refer to the “LAN Emulation Commands” chapter in the *Cisco IOS Switching Services Command Reference*.

ATM Configuration Task List

To configure ATM in Cisco 4500 and Cisco 4700 routers, complete the tasks in the following sections. The first task is required, and then you must configure at least one PVC or SVC. The virtual circuit options you configure must match in three places: on the router, on the ATM switch, and at the remote end of the PVC or SVC connection. The remaining tasks are optional.

- Enable the NPM
- Configure PVCs
- Configure SVCs
- Configure Classical IP and ARP over ATM (optional)
- Configure Traffic Shaping for ATM SVCs (optional)
- Customize the NPM (optional)
- Configure ATM Subinterfaces for SMDS Networks (optional)
- Configure Transparent Bridging for the NPM (optional)
- Configure PPP over ATM (optional)
- Monitor and Maintain the ATM Interface (optional)

See the “ATM Configuration Examples” section at the end of this chapter for configuration examples.

Enable the NPM

This section describes how to begin configuring the network processor module (NPM). The Cisco 4500 and Cisco 4700 identify an interface address by its unit number. To begin to configure the NPM, start the following task in privileged EXEC mode:

Task	Command
Step 1 At the privileged EXEC prompt, enter configuration mode from the terminal.	configure terminal
Step 2 Specify the NPM interface number.	interface atm number
Step 3 If IP routing is enabled on the system, optionally assign a source IP address and subnet mask to the interface.	ip address ip-address mask

To enable the ATM interface, perform the following task in interface configuration mode:

Task	Command
Change the shutdown state to up and enable the ATM interface, thereby starting the segmentation and reassembly (SAR) operation on the interface.	no shutdown

The **no shutdown** command passes an **enable** command to the NPM, which then begins segmentation and reassembly (SAR) operations. It also causes the NPM to configure itself based on the previous configuration commands sent.

Configure PVCs

To use a permanent virtual circuit (PVC), you must configure the PVC into both the router and the ATM switch. PVCs remain active until the circuit is removed from either configuration.

All virtual circuit characteristics listed in the section “NPM Virtual Circuits” in the “Wide-Area Networking Overview” chapter apply to these PVCs. When a PVC is configured, all the configuration options are passed on to the NPM. These PVCs are writable into the nonvolatile RAM (NVRAM) as part of the Route Processor (RP) configuration and are used when the RP image is reloaded.

Some ATM switches might have point-to-multipoint PVCs that do the equivalent of broadcasting. If a point-to-multipoint PVC exists, then that PVC can be used as the sole broadcast PVC for all multicast requests.

To configure a PVC, perform the tasks in the following sections. The first three tasks are required; the last two are optional:

- Create a PVC
- Map a Protocol Address to a PVC
- Configure Communication with the ILMI
- Configure ATM UNI Version Override (optional)
- Configure Transmission of Loopback Cells to Verify Connectivity (optional)

Create a PVC

To create a PVC on the NPM interface, perform the following task in interface configuration mode:

Task	Command
Create a PVC.	atm pvc <i>vcd vpi vci aal-encap</i> [[<i>midlow midhigh</i>] [<i>peak average burst</i>]] [<i>oam seconds</i>] [<i>inarp minutes</i>]

When you create a PVC, you create a virtual circuit descriptor (VCD) and attach it to the VPI and VCI. A VCD is an NPM-specific mechanism that identifies to the NPM which VPI-VCI pair to use for a particular packet. The NPM requires this feature to manage the packets for transmission. The number chosen for the VCD is independent of the VPI-VCI pair used.

When you create a PVC, you also specify the ATM adaptation layer (AAL) and encapsulation. If you specify AAL3/4-SMDS encapsulation, you have the option of setting the starting message identifier (MID) number and ending MID number using the *midlow* and *midhigh* arguments. A rate queue is used that matches the *peak* and *average* rate selections, which are specified in kilobits per second. Omitting a *peak* and *average* value causes the PVC to be connected to the highest bandwidth rate queue available. In this case, the *peak* and *average* values are equal.

You can also configure the PVC for communication with the Interim Local Management Interface (ILMI) so the router can receive Simple Network Management Protocol (SNMP) traps and new network prefixes. Refer to the “Configure Communication with the ILMI” section in this chapter for details.

You can also optionally configure the PVC to send Operation, Administration, and Maintenance (OAM) F5 loopback cells to verify connectivity on the virtual circuit. The remote end must respond by echoing back such cells.

See examples of PVC configurations on the Cisco 4500 in the section “ATM Configuration Examples” at the end of this chapter.

Map a Protocol Address to a PVC

The ATM interface supports a static mapping scheme that identifies the ATM address of remote hosts or routers. This address is specified as a virtual circuit descriptor (VCD) for a PVC (or an NSAP address for SVC operation). This section describes how to map a PVC to an address, which is a required task if you are configuring a PVC.

You enter mapping commands as groups. You first create a map list and then associate it with an interface. Begin the following tasks in global configuration mode:

Task	Command
Step 1 Create a map list by naming it, and enter map-list configuration mode.	map-list <i>name</i>
Step 2 Associate a protocol and address to a specific virtual circuit.	<i>protocol protocol-address atm-vc vcd</i> [broadcast]
Step 3 Associate a protocol and address to a different virtual circuit.	<i>protocol protocol-address atm-vc vcd</i> [broadcast]
Step 4 Specify the NPM interface number and enter interface configuration mode.	interface atm <i>number</i>
Step 5 Associate a map list to an interface.	map-group <i>name</i>

A map list can contain multiple map entries, as Steps 2 and 3 in the preceding task table illustrate. The **broadcast** keyword specifies that this map entry is to be used when the corresponding protocol sends broadcast packets to the interface (for example, any network routing protocol updates). If you do not specify **broadcast**, the ATM software is prevented from sending routing protocol updates to the remote host.

If you do specify **broadcast**, but do *not* set up point-to-multipoint signaling, pseudobroadcasting is enabled. To eliminate pseudobroadcasting and set up point-to-multipoint signaling on virtual circuits configured for broadcasting, see the “Configure Point-to-Multipoint Signaling” section in this chapter.

In Step 5, associate the map list with the ATM interface you specified in Step 4. Use the same *name* argument you used in the **map-list** command

You can create multiple map lists, but you can associate only one map list with an interface. Different map lists can be associated with different interfaces. See the examples at the end of this chapter.

Configure Communication with the ILMI

You can configure a PVC for communication with the Interim Local Management Interface (ILMI) so the router can receive SNMP traps and new network prefixes. The recommended *vpi* and *vci* values for the ILMI PVC are 0 and 16, respectively. To configure ILMI communication, complete the following task in interface configuration mode:

Task	Command
Create an ILMI PVC on a major interface.	atm pvc vcd vpi vci ilmi

Note This ILMI PVC can be set up only on a major interface, not on the subinterfaces.

Once you have configured an ILMI PVC, you can optionally enable the ILMI keepalive function by completing the following task in interface configuration mode:

Optionally, enable ILMI keepalives and set the interval between keepalives.	atm ilmi-keepalive [<i>seconds</i>]
-----------------------------------------------------------------------------	----------------------------------------------

No other configuration steps are required.

ILMI address registration for receipt of SNMP traps and new network prefixes is enabled by default. The ILMI keepalive function is disabled by default; when enabled, the default interval between keepalives is 3 seconds.

Configure ATM UNI Version Override

Normally, when ILMI link autodetermination is enabled on the interface and is successful, the router takes the user-network interface (UNI) version returned by ILMI. If the ILMI link autodetermination process is unsuccessful or ILMI is disabled, the UNI version defaults to 3.0. You can override this

default by using the **atm uni-version** command. The **no** form of the command sets the UNI version to the one returned by ILMI if ILMI is enabled and the link autodetermination is successful. Otherwise, the UNI version will revert to 3.0.

Task	Command
Override UNI version used by router.	atm uni-version <i>version number</i>

No other configuration steps are required.

Configure Transmission of Loopback Cells to Verify Connectivity

You can optionally configure the PVC to send OAM F5 loopback cells to verify connectivity on the virtual circuit. The remote end must respond by echoing back such cells. If OAM response cells are missed (indicating the lack of connectivity), the system console displays a debug message indicating the failure of the PVC, provided the **debug atm errors** command is enabled. If you suspect that a PVC is faulty, enabling OAM cell generation and the **debug atm errors** command allows you to monitor the status of the PVC.

To configure the transmission of OAM F5 loopback cells, add the **oam** keyword to the **atm pvc** command, as shown in the following task:

Task	Command
Configure transmission of OAM F5 cells on the PVC, specifying how often OAM F5 cells should be sent.	atm pvc <i>vcd vpi vci aal-encap</i> <i>[[midlow midhigh]</i> <i>[peak average burst]]</i> [oam seconds] [inarp minutes]

Configure SVCs

ATM switched virtual circuit (SVC) service operates much like X.25 SVC service, although ATM allows much higher throughput. Virtual circuits are created and released dynamically, providing user bandwidth on demand. This service requires a signaling protocol between the router and the switch.

The ATM signaling software provides a method of dynamically establishing, maintaining, and clearing ATM connections at the User-Network Interface (UNI). The ATM signaling software conforms to ATM Forum UNI 3.0 or ATM Forum UNI 3.1, depending on what version is selected by ILMI or configuration.

In UNI mode, the user is the router and the network is an ATM switch. This is an important distinction. The Cisco router does not perform ATM-level call routing; the ATM switch does the ATM call routing. The router routes packets through the resulting circuit. The router is viewed as the user and the LAN interconnection device at the end of the circuit, and the ATM switch is viewed as the network.

Figure 10 illustrates the router position in a basic ATM environment. The router is used primarily to interconnect LANs via an ATM network. The workstation connected directly to the destination ATM switch illustrates that you can connect not only routers to ATM switches, but also any computer with an ATM interface that conforms to the ATM Forum UNI specification.

Figure 10 Basic ATM Environment

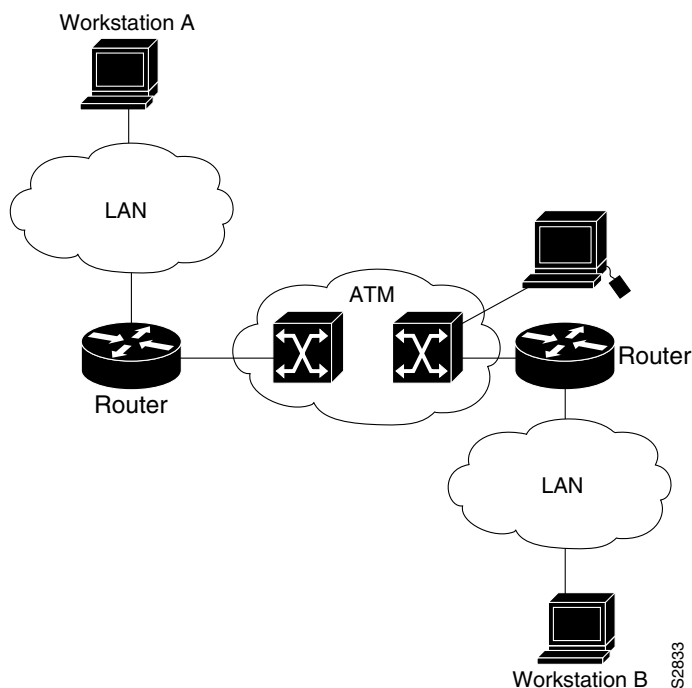

You must complete the tasks in the following sections to use SVCs:

- Configure the PVC That Performs SVC Call Setup
- Configure the NSAP Address

The tasks in the following sections are optional SVC tasks for customizing your network. These tasks are considered advanced; the default values are almost always adequate. You should not have to perform these tasks unless you need to customize your particular SVC connection.

- Configure the Idle Timeout Interval
- Configure Point-to-Multipoint Signaling
- Configure IP Multicast over ATM Point-to-Multipoint Virtual Circuits
- Change Traffic Values
- Configure SSCOP
- Close an SVC

Configure the PVC That Performs SVC Call Setup

Unlike X.25 service, which uses in-band signaling (connection establishment done on the same circuit as data transfer), ATM uses out-of-band signaling. This means that one dedicated PVC exists between the router and the ATM switch, over which all SVC call establishment and call termination requests flow. After the call is established, data transfer occurs over the SVC, from router to router. The signaling that accomplishes the call setup and teardown is called *Layer 3 signaling* or the *Q.2931 protocol*.

For out-of-band signaling, a signaling PVC must be configured before any SVCs can be set up. Figure 11 illustrates a signaling PVC from the source router to the ATM switch used to set up two SVCs. This is a fully meshed network; workstations A, B, and C all can communicate with each other.

Figure 11 One or More SVCs Require a Signaling PVC

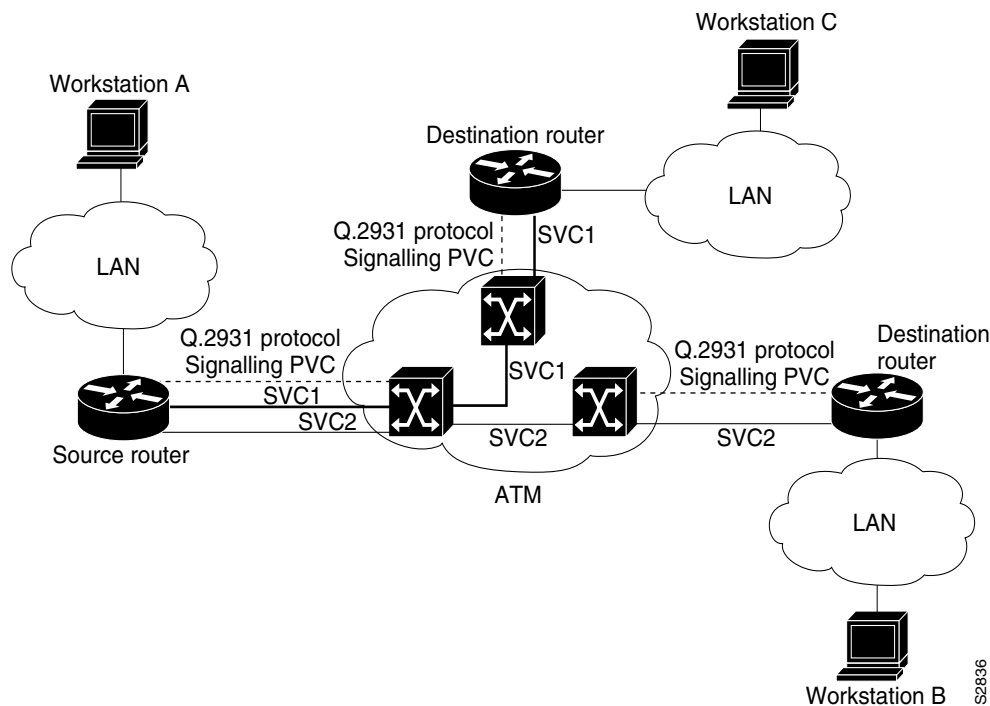

To configure the signaling PVC for all SVC connections, perform the following task in interface configuration mode:

Task	Command
Configure the signaling PVC for a major interface that uses SVCs.	<code>atm pvc vcd vpi vci qsaal</code>

Note This signaling PVC can be set up only on a major interface, not on the subinterfaces.

The VPI and VCI values must be configured consistently with the local switch. The standard value of VPI is 0; the standard value of VCI is 5.

See the section “SVCs in a Fully Meshed Network Example” at the end of this chapter for a sample ATM signaling configuration.

Configure the NSAP Address

Every ATM interface involved with signaling must be configured with an network service access point (NSAP) address. The NSAP address is the ATM address of the interface and must be unique across the network.

Complete one of the following tasks to configure an NSAP address:

- Configure the Complete NSAP Address Manually
- Configure the ESI and Selector Fields

If you choose to configure the end station ID (ESI) and selector fields, you also must configure a PVC to communicate with the switch via ILMI. The switch then provides the prefix field of the NSAP address.

Configure the Complete NSAP Address Manually

When you configure the ATM NSAP address manually, you must enter the entire address in hexadecimal format since each digit entered represents a hexadecimal digit. To represent the complete NSAP address, you must enter 40 hexadecimal digits in the following format:

```
xx . xxxx . xx . xxxxxx . xxxx . xxxx . xxxx . xxxx . xxxx . xxxx . xx
```

Note All ATM NSAP addresses may be entered in the dotted hexadecimal format shown, which conforms to the UNI specification. The dotted method provides some validation that the address is a legal value. If you know your address format is correct, the dots may be omitted.

Because the interface has no default NSAP address, you must configure the NSAP address for SVCs. To set the ATM interface's source NSAP address, perform the following task in interface configuration mode:

Task	Command
Configure the ATM NSAP address for an interface.	atm nsap-address <i>nsap-address</i>

See an example of assigning an NSAP address to an ATM interface in the section "ATM NSAP Address Example" at the end of this chapter.

Configure the ESI and Selector Fields

To use this method of entering the router's NSAP address, the switch must be capable of delivering the NSAP address prefix to the router via ILMI and the router must be configured with a PVC for communication with the switch via ILMI.

To configure the router to get the NSAP prefix from the switch and use locally entered values for the remaining fields of the address, complete the following tasks in interface configuration mode:

Task	Command
Step 1 Configure a PVC for communicating with the switch via ILMI.	atm pvc <i>vcd 0 16 ilmi</i>
Step 2 Enter the ESI and selector fields of the NSAP address.	atm esi-address <i>esi.selector</i>

The **atm esi-address** command allows you to configure the ATM address by entering the ESI (12 hexadecimal characters) and the selector byte (2 hexadecimal characters). The ATM prefix (26 hexadecimal characters) is provided by the ATM switch. To get the prefix from the ATM switch, the ILMI PVC must be configured on the router and the ATM switch must be able to supply a prefix via ILMI.

The **atm esi-address** and **atm nsap-address** commands are mutually exclusive. Configuring the router with the **atm esi-address** command negates the **atm nsap-address** setting, and vice versa.

You can also specify a keepalive interval for the ILMI PVC. See the “Configure Communication with the ILMI” section earlier in this chapter for more information.

To see an example of setting up the ILMI PVC and assigning the ESI and selector fields of an NSAP address, go to the section “ATM ESI Address Example” at the end of this chapter.

Configure the Idle Timeout Interval

You can specify an interval of inactivity after which any idle SVC on an interface is disconnected. This timeout interval might help control costs and free router memory and other resources for other uses.

To change the idle timeout interval, perform the following task in interface configuration mode:

Task	Command
Configure the interval of inactivity after which an idle SVC will be disconnected.	atm idle-timeout <i>seconds</i>

The default idle timeout interval is 300 seconds (5 minutes).

Configure Point-to-Multipoint Signaling

Point-to-multipoint signaling (or multicasting) allows the router to send one packet to the ATM switch and have the switch replicate the packet to the destinations. It replaces pseudobroadcasting on specified virtual circuits for protocols configured for broadcasting.

You configure multipoint signaling on an ATM interface after you have mapped protocol addresses to NSAPs and configured one or more protocols for broadcasting.

After multipoint signaling is set, the router uses existing static map entries that have the **broadcast** keyword set to establish multipoint calls. The call is established to the first destination with a Setup message. Additional parties are added to the call with AddParty messages each time a multicast packet is sent. One multipoint call will be established for each logical subnet of each protocol that has the **broadcast** keyword set.

To configure multipoint signaling on an ATM interface, complete the following tasks beginning in global configuration mode. The first task is required to configure this feature; the others are optional.

Task	Command
Step 1 Specify the NPM interface number.	interface atm <i>number</i>
Step 2 Provide a protocol address for the interface.	<i>protocol protocol-address mask</i>
Step 3 Associate a map list to the interface.	map-group <i>name</i>
Step 4 Provide an ATM NSAP address for the interface.	atm nsap-address <i>nsap-address</i>

Task	Command
Step 5 Configure the signaling PVC for the interface that uses SVCs.	atm pvc <i>vcd vpi vci</i> qsaal
Step 6 Associate a map list with the map group.	map-list <i>name</i>
Step 7 Configure a broadcast protocol for the remote NSAP address on the SVC. Repeat this step for other NSAP addresses, as needed.	<i>protocol protocol-address</i> atm-nsap <i>atm-nsap-address</i> broadcast
Step 8 Enable multipoint signaling to the ATM switch.	atm multipoint-signalling
Step 9 Limit the frequency of sending AddParty messages (optional).	atm multipoint-interval <i>interval</i>

If multipoint virtual circuits are closed, they are reopened with the next multicast packet. Once the call is established, additional parties are added to the call when additional multicast packets are sent. If a destination never comes up, the router constantly attempts to add it to the call by means of multipoint signaling.

For an example of configuring multipoint signaling on an interface that is configured for SVCs, see the “SVCs with Multipoint Signaling Example” later in this chapter.

Configure IP Multicast over ATM Point-to-Multipoint Virtual Circuits

This task is documented in the “Configuring IP Multicast Routing” chapter of the *Network Protocols Configuration Guide, Part 1*.

Change Traffic Values

The tasks in this section are optional and advanced. The ATM signaling software can specify to the NPM card and the ATM switch a limit on how much traffic the source router will be sending. It provides this information in the form of traffic parameters. (These parameters have default values.) The ATM switch in turn sends these parameters as requested by the source to the ATM destination node. If the destination cannot provide such capacity levels, the call may fail (for Cisco 4500 and 4700 behavior, see the per-interface **atm sig-traffic-shaping strict** command in the *Wide-Area Networking Command Reference*). There is a single attempt to match traffic parameters.

This section describes how to change traffic values to customize your SVC connection. The individual tasks that separately specify **peak**, **sustainable**, or **burst** values for an SVC are analogous to the *peak*, *average*, and *burst* values defined when you create a PVC. Valid values for the peak rate on the Cisco 4500 and Cisco 4700 routers are from 56 kbps to the PLIM rate, valid values for the average rate are from 1 kbps to the peak rate, and valid values for the maximum burst size are from 1 cell to 65535 cells.

Forward commands apply to the flow of cells from the source router to the destination router. Backward commands apply to the flow of cells from the destination router to the source router.

Most of the SVC traffic parameters include the concept of cell loss priority (CLP). CLP defines the following two levels of cell importance:

- A cell that has a CLP of 0 is a high-priority cell, indicating to the ATM switch that the switch should not readily discard the cell.
- A cell that has a CLP of 1 is a low-priority cell, indicating to the ATM switch that the switch can discard the cell if necessary due to congestion. For example, a cell with a CLP of 1 should be dropped before a cell with a CLP of 0.

Figure 12 illustrates a source and destination router implementing traffic settings that correspond end-to-end. The value for the forward command at the source router corresponds to the value for the backward command at the destination router.

Figure 12 Source and Destination Routers Have Corresponding Traffic Settings

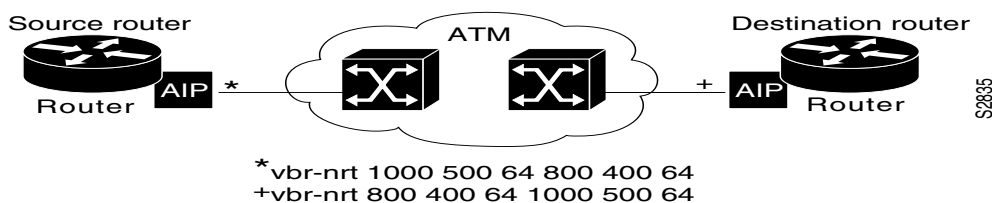

You can define map lists and map groups to tie specified SVCs to the protocol addresses of remote hosts and to specify whether broadcast protocols are supported. Then you can define map classes and specify the traffic parameters needed for the specified protocol traffic on those SVCs.

You must enter map-class configuration mode before you can change the traffic values from their default values. To enter map-class configuration mode, perform the following task in global configuration mode:

Task	Command
Enter map-class configuration mode, specifying a map-class name.	map-class atm class-name

If a map class with the specified name does not exist, the router creates a new one. All the following commands apply to the named map class.

See the “Traffic Parameters Example” section at the end of this chapter for an example defining map classes, map groups, map lists, and traffic parameters.

To change the traffic values from their default values, perform one or more of the following tasks in map-class configuration mode:

Task	Command
Set the source-to-destination peak cell rate for high-priority cells.	atm forward-peak-cell-rate-clp0 rate
Set the destination-to-source peak cell rate for high-priority cells.	atm backward-peak-cell-rate-clp0 rate
Set the source-to-destination peak cell rate for the aggregate of low-priority and high-priority cells.	atm forward-peak-cell-rate-clp1 rate
Set the destination-to-source peak cell rate for the aggregate of low-priority and high-priority cells.	atm backward-peak-cell-rate-clp1 rate

Task	Command
Set the source-to-destination sustainable cell rate for high-priority cells.	atm forward-sustainable-cell-rate-clp0 <i>rate</i>
Set the destination-to-source sustainable cell rate for high-priority cells.	atm backward-sustainable-cell-rate-clp0 <i>rate</i>
Set the source-to-destination sustainable cell rate for the aggregate of low-priority and high-priority cells.	atm forward-sustainable-cell-rate-clp1 <i>rate</i>
Set the destination-to-source sustainable cell rate for the aggregate of low-priority and high-priority cells.	atm backward-sustainable-cell-rate-clp1 <i>rate</i>
Set the source-to-destination burst size for high-priority cells.	atm forward-max-burst-size-clp0 <i>cell-count</i>
Set the destination-to-source burst size for high-priority cells.	atm backward-max-burst-size-clp0 <i>cell-count</i>
Set the source-to-destination burst size for the aggregate of low-priority and high-priority cells.	atm forward-max-burst-size-clp1 <i>cell-count</i>
Set the destination-to-source burst size for the aggregate of low-priority and high-priority cells.	atm backward-max-burst-size-clp1 <i>cell-count</i>

Configure SSCOP

The Service-Specific Connection-Oriented Protocol (SSCOP) resides in the service-specific convergence sublayer (SSCS) of the ATM adaptation layer (AAL). SSCOP is used to transfer variable-length service data units (SDUs) between users of SSCOP. SSCOP provides for the recovery of lost or corrupted SDUs.

Note The tasks in this section customize the SSCOP feature to a particular network or environment and are optional. The features have default values and are valid in most installations. Before customizing these features, you should have a good understanding of SSCOP and the network involved.

Set the Poll Timer

The poll timer controls the maximum time between transmission of a POLL PDU when SD or SDP PDUs are queued for transmission or are outstanding pending acknowledgments. To change the poll timer from the default value of 10 seconds, perform the following task in interface configuration mode:

Task	Command
Set the poll timer.	sscop poll-timer <i>seconds</i>

Set the Keepalive Timer

The keepalive timer controls the maximum time between transmission of a POLL PDU when no SD or SDP PDUs are queued for transmission or are outstanding pending acknowledgments. To change the keepalive timer from the default value of 30 seconds, perform the following task in interface configuration mode:

Task	Command
Set the keepalive timer.	sscop keepalive-timer <i>seconds</i>

Set the Connection Control Timer

The connection control timer determines the time between transmission of BGN, END, or RS (resynchronization) PDUs as long as an acknowledgment has not been received. Connection control performs the establishment, release, and resynchronization of an SSCOP connection.

To change the connection control timer from the default value of 10 seconds, perform the following task in interface configuration mode:

Task	Command
Set the connection control timer.	sscop cc-timer <i>seconds</i>

To change the retry count of the connection control timer from the default value of 10, perform the following task in interface configuration mode:

Task	Command
Set the number of times that SSCOP will retry to transmit BGN, END, or RS PDUs when they have not been acknowledged.	sscop max-cc <i>retries</i>

Set the Transmitter and Receiver Windows

A transmitter window controls how many packets can be transmitted before an acknowledgment is required. To change the transmitter's window from the default value of 7, perform the following task in interface configuration mode:

Task	Command
Set the transmitter's window.	sscop send-window <i>packets</i>

A receiver window controls how many packets can be received before an acknowledgment is required. To change the receiver's window from the default value of 7, perform the following task in interface configuration mode:

Task	Command
Set the receiver's window.	sscop rcv-window <i>packets</i>

Close an SVC

You can disconnect an idle SVC by completing the following task in EXEC mode:

Task	Command
Close the signaling PVC for an SVC.	atmsig close atm <i>number vcd</i>

Configure Classical IP and ARP over ATM

Cisco implements both the ATM Address Resolution Protocol (ARP) server and ATM ARP client functions described in RFC 1577. RFC 1577 models an ATM network as a logical IP subnetwork on a LAN.

The tasks required to configure classical IP and ARP over ATM depend on whether the environment uses SVCs or PVCs.

Configure Classical IP and ARP in an SVC Environment

The ATM ARP mechanism is applicable to networks that use SVCs. It requires a network administrator to configure only the device's own ATM address and that of a single ATM ARP server into each client device. When the client makes a connection to the ATM ARP server, the server sends ATM Inverse ARP requests to learn the IP network address and ATM address of the client on the network. It uses the addresses to resolve future ATM ARP requests from clients. Static configuration of the server is not required or needed.

In Cisco's implementation, the ATM ARP client tries to maintain a connection to the ATM ARP server. The ATM ARP server can tear down the connection, but the client attempts once each minute to bring the connection back up. No error messages are generated for a failed connection, but the client will not route packets until the ATM ARP server is connected and translates IP network addresses.

For each packet with an unknown IP address, the client sends an ATM ARP request to the server. Until that address is resolved, any IP packet routed to the ATM interface will cause the client to send another ATM ARP request. When the ARP server responds, the client opens a connection to the new destination so that any additional packets can be routed to it.

Cisco routers may be configured as ATM ARP clients to work with any ATM ARP server conforming to RFC 1577. Alternatively, one of the Cisco routers in a logical IP subnet (LIS) may be configured to act as the ATM ARP server itself. In this case, it automatically acts as a client as well. To configure classical IP and ARP in an SVC environment, perform the tasks in one of the following sections:

- Configure the Router as an ATM ARP Client
- Configure the Router as an ATM ARP Server

Configure the Router as an ATM ARP Client

In an SVC environment, configure the ATM ARP mechanism on the interface by performing the following tasks beginning in global configuration mode:

Task	Command
Step 1 Specify the NPM interface number.	interface atm <i>number</i>
Step 2 Specify the ATM address of the interface.	atm nsap-address <i>nsap-address</i>
Step 3 Specify the IP address of the interface.	ip address <i>address mask</i>
Step 4 Specify the ATM address of the ATM ARP server.	atm arp-server nsap <i>nsap-address</i>
Step 5 Enable the ATM interface.	no shutdown

You can designate the current router as the ATM ARP server in Step 4 by typing **self** instead of the NSAP address.

For an example of configuring the ATM ARP client, see the “ATM ARP Client Configuration in an SVC Environment Example” section later in this chapter.

Configure the Router as an ATM ARP Server

Cisco’s implementation of the ATM ARP server supports a single, nonredundant server per logical IP subnetwork (LIS) and supports one ATM ARP server per subinterface. Thus, a single NPM card can support multiple ARP servers by using multiple subinterfaces.

To configure the ATM ARP server, complete the following tasks beginning in global configuration mode:

Task	Command
Step 1 Specify the NPM interface number.	interface atm <i>number</i>
Step 2 Specify the ATM address of the interface.	atm nsap-address <i>nsap-address</i>
Step 3 Specify the IP address of the interface.	ip address <i>address mask</i>
Step 4 Identify the ATM ARP server for the IP subnetwork <i>network</i> and set the idle timer.	atm arp-server time-out <i>minutes</i> ¹
Step 5 Enable the ATM interface.	no shutdown

1. When you use this form of the **atm arp-server** command, it indicates that this interface will perform the ATM ARP server functions. When you configure the ATM ARP client (as described earlier), the **atm arp-server** command is used—with a different keyword and argument—to identify a different ATM ARP server to the client.

You can designate the current router as the ATM ARP server in Step 4 by typing **self** instead of the NSAP address.

The idle timer interval is the number of minutes a destination entry listed in the ATM ARP server’s ARP table can be idle before the server takes any action to time out the entry.

For an example of configuring the ATM ARP server, see the “ATM ARP Server Configuration in an SVC Environment Example” section later in this chapter.

Configure Classical IP and Inverse ARP in a PVC Environment

The ATM Inverse ARP mechanism is applicable to networks that use PVCs, where connections are established but the network addresses of the remote ends are not known. A server function is *not* used in this mode of operation.

In a PVC environment, configure the ATM Inverse ARP mechanism by performing the following tasks, beginning in global configuration mode:

Task	Command
Step 1 Specify the NPM interface number and enter interface configuration mode.	interface atm <i>number</i>
Step 2 Create a PVC and enable Inverse ARP on it.	atm pvc vcd vci aal5snap inarp <i>minutes</i> ¹
Step 3 Enable the ATM interface.	no shutdown

1. Additional options are permitted in this command, but the order of options is important.

Repeat Step 2 for each PVC you want to create.

The **inarp** *minutes* interval specifies how often Inverse ARP datagrams will be sent on this virtual circuit. The default value is 15 minutes.

Note The ATM ARP and Inverse ATM ARP mechanisms work with IP only. All other protocols require **map-list** command entries to operate.

For an example of configuring the ATM Inverse ARP mechanism, see the “ATM Inverse ARP Configuration in a PVC Environment Example” section later in this chapter.

Configure Traffic Shaping for ATM SVCs

When you configure SVCs, you can define an ATM class to add support for traffic shaping on ATM SVCs. This applies a map class to an ATM interface. When an outgoing call is made by a static map client, or by a classical IP over ATM client, a map class will be determined for the call.

You must enter map-class configuration mode before you can define an ATM class. To enter map-class configuration mode and specify the ATM class for an ATM interface, perform the following tasks in global configuration mode:

Task	Command
Enter map-class configuration mode, specifying a map-class name.	map-class atm <i>class-name</i>
Specify an ATM class for an ATM interface.	atm class <i>class-name</i>

You can specify that an SVC be established on an ATM interface using only signaled traffic parameters. When you configure strict traffic-shaping on the router ATM interface, an SVC is established only if traffic shaping can be provided for the transmit cell flow per the signaled traffic parameters. If such shaping cannot be provided, the SVC is released.

If you do not configure strict traffic-shaping on the router ATM interface, an attempt is made to establish an SVC with traffic shaping for the transmit cell flow per the signaled traffic parameters. If such shaping cannot be provided, the SVC is installed with default shaping parameters; that is, it behaves as though a PVC were created without specifying traffic parameters.

To specify that an SVC be established on an ATM interface using only signaled traffic parameters, perform the following task in interface configuration mode:

Task	Command
Specify that an SVC be established on an ATM interface using only signaled traffic parameters.	atm sig-traffic-shaping strict

Customize the NPM

You can customize the NPM interface on the Cisco 4500 and Cisco 4700 routers. The features you can customize have default values that will most likely suit your environment and probably need not be changed. However, you might need to enter configuration commands, depending upon the requirements for your system configuration and the protocols you plan to route on the interface. Perform the tasks in the following sections if you need to customize the NPM:

- Configure the Rate Queue
- Configure MTU Size
- Set the PLIM Framing
- Set Loopback Mode

- Set the VCI-to-VPI Ratio
- Set the Source of the Transmit Clock

Configure the Rate Queue

A rate queue defines the speed at which individual virtual circuits will transmit data to the remote end. You can configure permanent rate queues, allow the software to set up dynamic rate queues, or perform some combination of the two. The software dynamically creates rate queues when an **atm pvc** command specifies a peak/average rate that does not match any user-configured rate queue. The software dynamically creates all rate queues if you have not configured any.

Use Dynamic Rate Queues

The Cisco IOS software automatically creates rate queues as necessary to satisfy the requests of **atm pvc** commands. The peak rate for a virtual circuit descriptor (VCD) is set to the maximum that the physical layer interface module (PLIM) will allow, and the average rate is set equal to the peak rate; then a rate queue is dynamically created for the peak rate of the VCD.

If dynamic rate queues do not satisfy your traffic shaping needs, you can configure permanent rate queues.

See the “Dynamic Rate Queue Examples” section for examples of different rate queues created in response to **atm pvc** commands.

Configure a Permanent Rate Queue

The NPM supports up to four different peak rates. The peak rate is the maximum rate, in kilobits per second, at which a virtual circuit can transmit. Once attached to this rate queue, the virtual circuit is assumed to have its peak rate set to that of the rate queue.

You can configure each permanent rate queue independently to a portion of the overall bandwidth available on the ATM link. The combined bandwidths of all rate queues should not exceed the total bandwidth available. A warning message is displayed if you attempt to configure the combined rate queues beyond what is available to the NPM. The total bandwidth depends on the PLIM (see the “NPM Interface Types” section in the “Wide-Area Networking Overview” chapter).

To set a permanent rate queue, perform the following task in interface configuration mode:

Task	Command
Configure a permanent rate queue, which defines the maximum speed at which an individual virtual circuit transmits data to a remote ATM host.	atm rate-queue <i>queue-number speed</i>

Note In Cisco IOS Release 11.3, a permanent rate queue is automatically configured when you configure the peak rate using the **atm pvc** command. Therefore, you are not required to use the **atm rate-queue** command to configure the permanent rate queue.

Configure MTU Size

Each interface has a default maximum packet size or maximum transmission unit (MTU) size. On the NPM, this number defaults to 4470 bytes; the maximum is 9188 bytes. The MTU can be set on a per sub-interface basis as long as the interface MTU is as large or larger than the largest sub-interface MTU. To set the maximum MTU size, perform the following task in interface configuration mode:

Task	Command
Set the maximum MTU size.	mtu bytes

Set the PLIM Framing

The default SONET PLIM is STS-3C. To set the SONET PLIM to STM-1 or to set the PLIM framing for E3 or DS3, perform one of the following tasks in interface configuration mode:

Task	Command
Set the OC-3c SONET PLIM to STM-1.	atm sonet stm-1
or Set DS3 framing mode.	atm framing [m23adm cbitplcp m23plcp]
or Set E3 framing mode.	atm framing [g832adm g751adm]

The default for DS3 is C-Bit ADM framing; the default for E3 is G.751 with PLCP framing.

Set Loopback Mode

To loop all packets back to the NPM instead of the network, perform the following task in interface configuration mode:

Task	Command
Set loopback mode.	loopback diagnostic

To loop the incoming network packets back to the ATM network, perform the following task in interface configuration mode:

Task	Command
Set line loopback mode.	loopback line

Set the VCI-to-VPI Ratio

By default, the NPM supports 1024 VCIs per VPI. This value can be any power of 2 in the range from 32 to 8192. This value controls the memory allocation in the NPM to deal with the VCI table. It defines only the maximum number of VCIs to support per VPI.

To set the maximum number of VCIs to support per VPI and limit the highest VCI accordingly, perform the following task in interface configuration mode:

Task	Command
Set the number of VCIs per VPI.	atm vc-per-vp number

The product of VC and VP is fixed at 8192; the number of virtual circuits supported per virtual path will decrease in proportion to an increase in the number of virtual paths.

Set the Source of the Transmit Clock

By default, the NPM expects the ATM switch to provide transmit clocking. To specify that the NPM generate the transmit clock internally for SONET and E3 PLIM operation, perform the following task in interface configuration mode:

Task	Command
Specify that the NPM generate the transmit clock internally.	atm clock internal

Configure ATM Subinterfaces for SMDS Networks

An ATM adaptation layer (AAL) defines the conversion of user information into cells by segmenting upper-layer information into cells at the transmitter and reassembling them at the receiver. AAL1 and AAL2 handle isochronous traffic, such as voice and video, and are not relevant to the router. AAL3/4 and AAL5 support data communications by segmenting and reassembling packets. Release 11.0(5) supports both AAL3/4 and AAL5 on Cisco 4500 series routers.

Our implementation of the AAL3/4 encapsulates each AAL3/4 packet in a Switched Multimegabit Data Service (SMDS) header and trailer. This feature supports both unicast and multicast addressing, and provides subinterfaces for up to four AAL3/4 connections over the same physical interface.

Note Each subinterface configured to support AAL3/4 is allowed only one SMDS E.164 unicast address and one E.164 multicast address. The multicast address is used for all broadcast operations. In addition, only one virtual circuit is allowed on each subinterface that is being used for AAL3/4 processing, and it must be an AAL3/4 virtual circuit.

Support for AAL3/4 on an ATM interface requires static mapping of all protocols except IP. However, dynamic routing of IP can coexist with static mapping of other protocols on the same ATM interface.

To configure an ATM interface for SMDS networks, perform the following tasks in interface configuration mode:

Task	Command
Step 1 Provide an SMDS E.164 unicast address for the subinterface.	atm smds-address <i>address</i>
Step 2 Provide an SMDS E.164 multicast address.	atm multicast <i>address</i>
Step 3 Create an AAL3/4 PVC.	atm pvc <i>vcd vpi vci aal34smds</i>

Note AAL3/4 is not supported at OC-3c rates on Cisco 4500 series routers. If AAL3/4 is configured on an OC-3c interface, it must be limited to E3 or DS3 rates by setting up a permanent rate queue for the interface. See the “Configure the Rate Queue” section.

After configuring the ATM interface for SMDS networks, configure the interface for standard protocol configurations, as needed. For more information about protocol configuration, refer to the relevant chapters of the *Network Protocols Configuration Guide, Part 1*, the *Network Protocols Configuration Guide, Part 2*, and the *Network Protocols Configuration Guide, Part 3*.

For examples of configuring an ATM interface for AAL3/4 support, see the “PVC with AAL3/4 and SMDS Encapsulation Examples” section later in this chapter. Unlike the Cisco 7500 AAL3/4, the **aal** command to enable aal3/4, the **mid-per-vc** command, and the **vp-filter** command are not used on the Cisco 4500 or the Cisco 4700 routers.

Configure Transparent Bridging for the NPM

Our implementation of transparent bridging over ATM on the Cisco 4500 and Cisco 4700 routers allows the spanning tree for an interface to support virtual circuit descriptors (VCDs) for AAL5-LLC Subnetwork Access Protocol (SNAP) encapsulations.

If the relevant interface or subinterface is explicitly put into a bridge group, as described in the following task table, AAL5-SNAP encapsulated bridge packets on a PVC are fast-switched.

Our bridging implementation supports IEEE 802.3 frame formats and IEEE 802.10 frame formats. The router can accept IEEE 802.3 frames with or without frame check sequence (FCS). When the router receives frames with FCS (RFC 1483 bridge frame formats with 0x0001 in the PID field of the SNAP header), it strips off the FCS and forwards the frame as necessary. All IEEE 802.3 frames that originate at or are forwarded by the router are sent as 802.3 bridge frames without FCS (bridge frame formats with 0x0007 in the PID field of the SNAP header).

Note Transparent bridging for ATM on the Cisco 4500 works only on AAL5-LLC/SNAP PVCs (fast-switched). AAL3/4-SMDS, AAL5-MUX, and AAL5-NLPID bridging are not yet supported on the Cisco 4500. Transparent bridging for ATM also does not operate in a switched virtual circuit (SVC) environment.

To configure transparent bridging for LLC/SNAP PVCs, complete the following steps beginning in global configuration mode:

Task	Command
Step 1 Specify the NPM interface number and, optionally, a subinterface.	interface atm <i>number</i> [<i>.subinterface</i>]
Step 2 Assign a source IP address and subnet mask to the interface, if needed.	ip address <i>ip-address mask</i>
Step 3 Create one or more PVCs using AAL5-SNAP encapsulation.	atm pvc <i>vcd vpi vci aal5snap</i> atm pvc <i>vcd vpi vci aal5snap</i> atm pvc <i>vcd vpi vci aal5snap</i>
Step 4 Assign the interface to a bridge group.	bridge-group <i>group</i>
Step 5 Return to global configuration mode.	exit
Step 6 Define the type of spanning tree protocol as DEC.	bridge group protocol <i>dec</i>

No other configuration is required. Spanning tree updates are broadcast to all AAL5-SNAP virtual circuits that exist on the ATM interface. Only the AAL5-SNAP virtual circuits on the specific subinterface receive the updates. The router does not send spanning tree updates to AAL5-MUX and AAL5-NLPID virtual circuits.

For an example of transparent bridging for an AAL5-SNAP PVC, see the “Transparent Bridging on an AAL5-SNAP PVC Example” section.

Configure PPP over ATM

This section describes how to configure the NPM on the Cisco 4500 and 4700 routers to terminate multiple remote Point-to-Point Protocol (PPP) connections.

Before configuring PPP over ATM, the Cisco 4500 and 4700 routers must be equipped with Cisco IOS Release 11.2(4)F or later software. Remote branch offices must have PPP configured on PPP-compatible devices interconnecting directly to Cisco StrataCom’s ATM Switch Interface Shelf (AXIS) equipment through a leased-line connection. The AXIS shelves provide frame forwarding encapsulation and are terminated on BPX cores prior to connecting to a Cisco 4500 or Cisco 4700 router. Figure 13 shows a typical scenario for using PPP over ATM.

Figure 13 PPP-over-ATM Network Environment

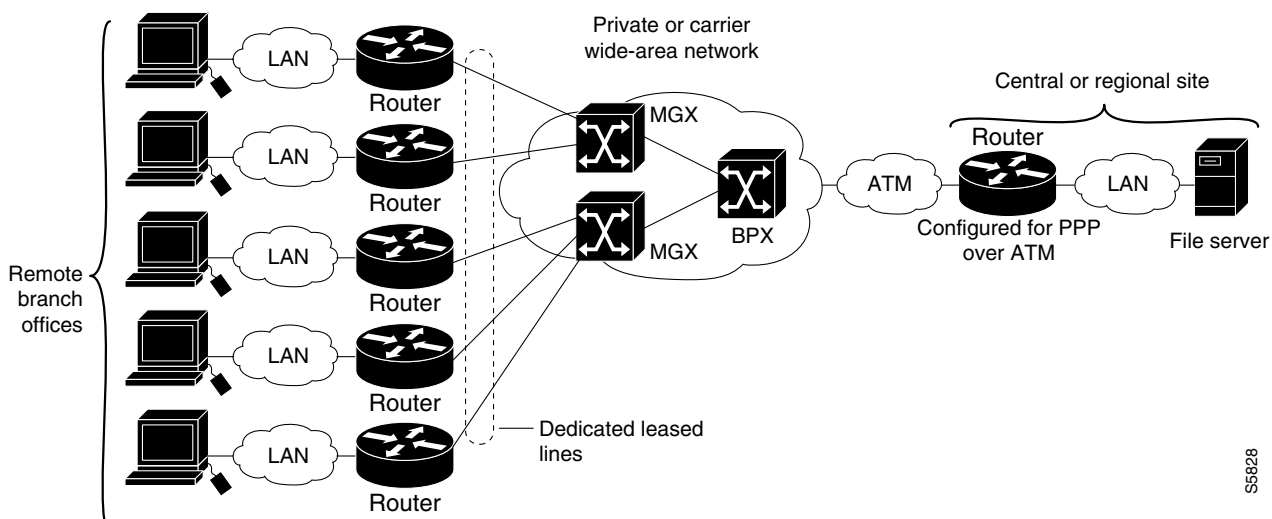

Note If you need to configure the Cisco StrataCom AXIS shelf for frame forwarding at the remote sites, refer to the *AXIS 4 Command Supplement* for command line instructions or the *StrataView Plus Operations Guide* for StrataView Plus instructions. If you configure the AXIS using the command line interface, use the **addport** and **addchan** commands and select frame forwarding for the *port_type* and *chan_type* arguments, respectively.

When you configure PPP over ATM, a logical interface known as a virtual access interface associates each PPP connection to an ATM permanent virtual circuit (PVC). You can create this logical interface by configuring an ATM PVC as described in the “Create a PPP-over-ATM PVC” section. This configuration encapsulates each PPP connection in a separate PVC, allowing each PPP connection to terminate at the router ATM interface as if received from a typical PPP serial interface.

The virtual access interface for each PVC obtains its configuration from a virtual interface template (virtual template) when the PVC is created. Before creating the ATM PVC, we suggest you create and configure a virtual template as described in the “Create and Configure a Virtual Template” section.

To configure PPP over ATM, complete the tasks in the following sections. The first task is optional but recommended. The remaining tasks are required.

- Create and Configure a Virtual Template
- Specify an ATM Point-to-Point Subinterface
- Create a PPP-over-ATM PVC

See an example of configuring PPP over ATM in the section “PPP-over-ATM Example” at the end of this chapter.

Create and Configure a Virtual Template

Prior to configuring the ATM PVC for PPP over ATM, you typically create and configure a virtual template. To create and configure a virtual template, complete the following tasks beginning in global configuration mode:

Task	Command
Step 1 Create a virtual template, and enter interface configuration mode.	interface virtual-template <i>number</i>
Step 2 Enable PPP encapsulation on the virtual template.	encapsulation ppp
Step 3 Optionally, enable PPP encapsulation on the virtual interface template.	ip unnumbered ethernet <i>number</i>

Other optional configuration commands can be added to the virtual template configuration. For example, you can enable the PPP authentication on the virtual template using the **ppp authentication chap** command. Refer to the “Configuring Virtual Interface Templates” chapter in the *Dial Solutions Configuration Guide* for additional information about configuring the virtual template.

All PPP parameters are managed within the virtual template configuration. Configuration changes made to the virtual template are automatically propagated to the individual virtual access interfaces. Multiple virtual access interfaces can spawn from a single virtual template; hence, multiple PVCs can use a single virtual template.

Cisco IOS software supports up to 25 virtual template configurations. If greater numbers of tailored configurations are required, an authentication, authorization, and accounting (AAA) server may be employed. Refer to the “Per-User Configuration” chapter in the *Dial Solutions Configuration Guide* for further information on configuring an AAA server.

If the parameters of the virtual template are not explicitly defined before configuring the ATM PVC, the PPP interface is brought up using default values from the virtual template identified. Some parameters (such as an IP address) take effect only if specified before the PPP interface comes up. Therefore, it is recommended that you explicitly create and configure the virtual template before configuring the ATM PVC to ensure such parameters take effect. Alternatively, if parameters are specified after the ATM PVC has already been configured, you should issue a **shutdown** command followed by a **no shutdown** command on the ATM subinterface to restart the interface; this restart will cause the newly configured parameters (such as an IP address) to take effect.

Network addresses for the PPP-over-ATM connections are not configured on the main ATM interface or subinterface. Instead, these are configured on the appropriate virtual template or obtained via AAA.

The virtual templates support all standard PPP configuration commands; however, not all configurations are supported by the PPP-over-ATM virtual access interfaces. These restrictions are enforced at the time the virtual template configuration is applied (cloned) to the virtual access interface. These restrictions are described in the following paragraphs.

Only standard first-in, first-out (FIFO) queuing is supported when applied to PPP-over-ATM virtual access interfaces. Other types of queuing which are typically configured on the main interface are not (for example, fair-queuing). If configured, these configuration lines are ignored when applied to a PPP-over-ATM interface.

While fast switching is supported, flow and optimum switching are not; these configurations are ignored on the PPP-over-ATM virtual access interface. Fast switching is enabled by default for the virtual template configuration. If fast switching is not desired, use the **no ip route-cache** command to disable it.

The PPP reliable link that uses Link Access Procedure, Balanced (LAPB) is not supported.

Because an ATM PVC is configured for this feature, the following standard PPP features are not applicable and should not be configured:

- Asynchronous interfaces
- Dialup connections
- Callback on PPP

Specify an ATM Point-to-Point Subinterface

After you create a virtual template for PPP over ATM, you must specify a point-to-point subinterface per PVC connection. To specify an ATM point-to-point subinterface, complete the following task beginning in global configuration mode:

Task	Command
Specify an ATM point-to-point subinterface.	interface atm <i>number.subinterface-number</i> point-to-point

Create a PPP-over-ATM PVC

After you create a virtual template and point-to-point subinterfaces for PPP over ATM, you must create a PPP-over-ATM PVC. To create a PPP-over-ATM PVC, perform the following task in subinterface configuration mode:

Task	Command
Create a PPP-over-ATM PVC.	atm pvc <i>vcd vpi vci aal5ciscopp</i> [<i>peak average [burst]</i>] [<i>oam [seconds]</i>] virtual-template <i>number</i>

The *peak* rate value is typically identical to the *average* rate or some suitable multiple thereof (the *peak* rate value is an unlimited multiple of the *average* rate value for the Cisco 4500 and 4700 routers).

The *average* rate value should be set to the line rate available at the remote site, because the remote line rate will have the lowest speed of the connection. For example, if the remote site has a T1 link, set the line rate to 1.536 Mbps. Because the average rate calculation on the ATM PVC includes the cell headers, a line rate value plus 10 or 15 percent may result in better remote line utilization.

The *burst* size depends on the number of cells that can be buffered by receiving ATM switches and is coordinated with the ATM network connection provider. If this value is not specified, the default, which is the equivalent to one maximum length frame on the interface, is used.

Operations, Administration and Maintenance (OAM) F5 cell loopback is provided by the remote AXIS shelf so OAM may be enabled. However, PPP over ATM is not typically an end-to-end ATM connection, and therefore enabling OAM is not recommended.

Once you configure the router for PPP over ATM, the PPP subsystem starts and the router attempts to send a PPP configure request to the remote peer. If the peer does not respond, the router periodically goes into a “listen” state and waits for a configuration request from the peer. After a timeout (typically 45 seconds), the router again attempts to reach the remote router by sending configuration requests.

The virtual access interface remains associated with a PVC as long as the PVC is configured. If you deconfigure the PVC, the virtual access interface is marked as deleted. If you shut down the associated ATM interface, you will also cause the virtual access interface to be marked as down (within 10 seconds), and you will bring the PPP connection down. If you set a keepalive timer of the virtual template on the interface, the virtual access interface uses the PPP echo mechanism to verify the existence of the remote peer. If an interface failure is detected and the PPP connection is brought down, the virtual access interface remains up.

Monitor and Maintain the ATM Interface

After configuring the new interface, you can display its status. You can also display the current state of the ATM network and connected virtual circuits. To show current virtual circuits and traffic information, perform the following tasks in EXEC mode:

Task	Command
Display ATM-specific information about an ATM interface.	show atm interface <i>atm number</i>
Display the configured list of ATM static maps to remote hosts on an ATM network.	show atm map
Display global traffic information to and from all ATM networks connected to the router. Display a list of counters of all ATM traffic on this router.	show atm traffic
Display ATM virtual circuit information about all PVCs and SVCs (or a specific virtual circuit).	show atm vc [<i>vcd</i>]
Display statistics for the ATM interface.	show interfaces atm <i>number</i>
Display SSCOP details for the ATM interface.	show sscop

ATM Configuration Examples

The examples in the following sections illustrate how to configure an ATM interface on the NPM for Cisco 4500 and Cisco 4700 routers:

- PVC with AAL5 and LLC/SNAP Encapsulation Examples
- PVCs in a Fully Meshed Network Example

- SVCs in a Fully Meshed Network Example
- ATM NSAP Address Example
- ATM ESI Address Example
- SVCs with Multipoint Signaling Example
- Traffic Parameters Example
- Classical IP and ARP Examples
- Dynamic Rate Queue Examples
- Transparent Bridging on an AAL5-SNAP PVC Example
- PPP-over-ATM Example

PVC with AAL5 and LLC/SNAP Encapsulation Examples

The following example creates PVC 5 on ATM interface 0. It uses LLC/SNAP encapsulation over AAL5. The interface is at IP address 1.1.1.1 with 1.1.1.5 at the other end of the connection. The static map list named *atm* declares that the next node is a broadcast point for multicast packets from IP. For further information, refer to the related task section “Create a PVC” presented earlier in this chapter.

```
interface atm 0
 ip address 1.1.1.1 255.255.255.0
 atm rate-queue 1 100
 atm pvc 5 0 10 aal5snap
 ip route-cache cbus
 map-group atm
!
map-list atm
 ip 1.1.1.5 atm-vc 5 broadcast
```

The following example is of a typical ATM configuration for a PVC:

```
interface atm 0
 ip address 172.21.168.112 255.255.255.0
 map-group atm
 atm rate-queue 1 100
 atm pvc 1 1 1 aal5snap
 atm pvc 2 2 2 aal5snap
 atm pvc 6 6 6 aal5snap
 atm pvc 7 7 7 aal5snap
 decnet cost 1
 clns router iso-igrp comet
!
router iso-igrp comet
 net 47.0004.0001.0000.0c00.6666.00
!
router igrp 109
 network 172.21.0.0
!
 ip domain-name CISCO.COM
!
map-list atm
 ip 172.21.168.110 atm-vc 1 broadcast
 clns 47.0004.0001.0000.0c00.6e26.00 atm-vc 6 broadcast
 decnet 10.1 atm-vc 2 broadcast
```

PVCs in a Fully Meshed Network Example

Figure 14 illustrates a fully meshed network. The configurations for Routers A, B, and C follow the figure. In this example, the routers are configured to use PVCs. *Fully meshed* indicates that any workstation can communicate with any other workstation. Note that the two **map-list** statements configured in Router A identify the ATM addresses of Routers B and C. The two **map-list** statements in Router B identify the ATM addresses of Routers A and C. The two **map list** statements in Router C identify the ATM addresses of Routers A and B. For further information, refer to the related task section “Create a PVC” presented earlier in this chapter.

Figure 14 Fully Meshed ATM Configuration Example

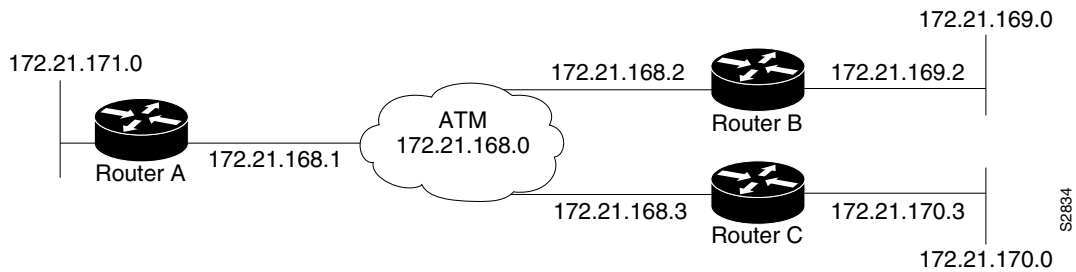

Router A

```
ip routing
!
interface atm 0
 ip address 131.108.168.1 255.255.255.0
 atm rate-queue 1 100
 atm pvc 1 0 10 aal5snap
 atm pvc 2 0 20 aal5snap
 map-group test-a
!
map-list test-a
 ip 131.108.168.2 atm-vc 1 broadcast
 ip 131.108.168.3 atm-vc 2 broadcast
```

Router B

```
ip routing
!
interface atm 0
 ip address 131.108.168.2 255.255.255.0
 atm rate-queue 1 100
 atm pvc 1 0 20 aal5snap
 atm pvc 2 0 21 aal5snap
 map-group test-b
!
map-list test-b
 ip 131.108.168.1 atm-vc 1 broadcast
 ip 131.108.168.3 atm-vc 2 broadcast
```

Router C

```

ip routing
!
interface atm 0
 ip address 131.108.168.3 255.255.255.0
 atm rate-queue 1 100
 atm pvc 2 0 21 aal5snap
 atm pvc 4 0 22 aal5snap
 map-group test-c
!
map-list test-c
 ip 131.108.168.1 atm-vc 2 broadcast
 ip 131.108.168.2 atm-vc 4 broadcast

```

SVCs in a Fully Meshed Network Example

The following example is also a configuration for the fully meshed network shown in Figure 14, but this example uses SVCs. PVC 1 is the signaling PVC. For further information, refer to the related task section “Configure the PVC That Performs SVC Call Setup” presented earlier in this chapter.

Router A

```

interface atm 0
 ip address 131.108.168.1 255.255.255.0
 map-group atm
 atm nsap-address AB.CDEF.01.234567.890A.BCDE.F012.3456.7890.1234.12
 atm rate-queue 1 100
 atm maxvc 1024
 atm pvc 1 0 5 qsaal
!
map-list atm
 ip 131.108.168.2 atm-nsap BC.CDEF.01.234567.890A.BCDE.F012.3456.7890.1334.13
 ip 131.108.168.3 atm-nsap BC.CDEF.01.234567.890A.BCDE.F012.3456.7890.1224.12

```

Router B

```

interface atm 0
 ip address 131.108.168.2 255.255.255.0
 map-group atm
 atm nsap-address BC.CDEF.01.234567.890A.BCDE.F012.3456.7890.1334.13
 atm rate-queue 1 100
 atm pvc 1 0 5 qsaal
!
map-list atm
 ip 131.108.168.1 atm-nsap AB.CDEF.01.234567.890A.BCDE.F012.3456.7890.1234.12
 ip 131.108.168.3 atm-nsap BC.CDEF.01.234567.890A.BCDE.F012.3456.7890.1224.12

```

Router C

```

interface atm 0
 ip address 131.108.168.3 255.255.255.0
 map-group atm
 atm nsap-address BC.CDEF.01.234567.890A.BCDE.F012.3456.7890.1224.12
 atm rate-queue 1 100
 atm pvc 1 0 5 qsaal
!
map-list atm
 ip 131.108.168.1 atm-nsap AB.CDEF.01.234567.890A.BCDE.F012.3456.7890.1234.12
 ip 131.108.168.2 atm-nsap BC.CDEF.01.234567.890A.BCDE.F012.3456.7890.1334.13

```

ATM NSAP Address Example

The following example assigns NSAP address AB.CDEF.01.234567.890A.BCDE.F012.3456.7890.1234.12 to ATM interface 0. For further information, refer to the related task section “Configure the Complete NSAP Address Manually” presented earlier in this chapter.

```
interface atm 0
  atm nsap-address AB.CDEF.01.234567.890A.BCDE.F012.3456.7890.1234.12
```

You can display the ATM address for the interface by executing the **show interface atm** command.

ATM ESI Address Example

The following example on a Cisco 4500 router assigns the ESI and selector field values and sets up the ILMI PVC. For further information, refer to the related task section “Configure the ESI and Selector Fields” presented earlier in this chapter.

```
interface atm 0
  atm pvc 2 0 16 ilmi
  atm esi-address 345678901234.12
```

SVCs with Multipoint Signaling Example

The following example configures an ATM interface for SVCs using multipoint signaling. For further information, refer to the related task section “Configure Point-to-Multipoint Signaling” presented earlier in this chapter.

```
interface atm 0
  ip address 4.4.4.6
  map-group atm_pri
  atm nsap-address de.cdef.01.234567.890a.bcde.f012.3456.7890.1234.12
  atm multipoint-signalling
  atm rate-queue 1 100
  atm pvc 1 0 5 qsaal
  !
  map-list atm_pri
  ip 4.4.4.4 atm-nsap cd.cdef.01.234566.890a.bcde.f012.3456.7890.1234.12 broadcast
  ip 4.4.4.7 atm-nsap 31.3233.34.353637.3839.3031.3233.3435.3637.3839.30 broadcast
```

Traffic Parameters Example

The following example defines a map list to tie specified SVCs to protocol addresses of remote hosts and to specified map classes. Then it defines the map classes and sets traffic parameters for certain protocol traffic. For further information, refer to the related task section “Change Traffic Values” presented earlier in this chapter.

```
map-list atmlist
  ip 131.108.170.21 atm-vc 12
  ip 131.108.180.121 atm-nsap 47.0091.81.000000.0041.0B0A.1581.0040.0B0A.1585.00 class atmclass1
  ip 131.108.190.221 atm-nsap 47.0091.81.000000.0041.0B0A.1581.0040.0B0B.1585.00 class atmclass2
map-class atm atmclass1
  atm forward-peak-cell-rate-clp1 8000
  atm backward-peak-cell-rate-clp1 8000
map-class atm atmclass2
  atm forward-peak-cell-rate-clp1 7000
  atm backward-peak-cell-rate-clp1 7000
interface atm 0
  map-group atmlist
```

Classical IP and ARP Examples

This section provides three examples of classical IP and ARP configuration, one each for a client and a server in an SVC environment, and one for ATM Inverse ARP in a PVC environment.

ATM ARP Client Configuration in an SVC Environment Example

This example configures an ATM ARP client in an SVC environment. Note that the client in this example and the ATM ARP server in the next example are configured to be on the same IP network. For further information, refer to the related task section “Configure the Router as an ATM ARP Client” presented earlier in this chapter.

```
interface atm 0.5
 atm nsap-address ac.2456.78.040000.0000.0000.0000.0000.0000.00
 ip address 10.0.0.2 255.0.0.0
 atm pvc 1 0 5 qsaal
 atm arp-server nsap ac.1533.66.020000.0000.0000.0000.0000.0000.00
```

ATM ARP Server Configuration in an SVC Environment Example

The following example configures ATM on an interface and configures the interface to function as the ATM ARP server for the IP subnetwork. For further information, refer to the related task section “Configure the Router as an ATM ARP Server” presented earlier in this chapter.

```
interface atm 0
 ip address 10.0.0.1 255.0.0.0
 atm nsap-address ac.1533.66.020000.0000.0000.0000.0000.0000.00
 atm rate-queue 1 100
 atm pvc 1 0 5 qsaal
 atm arp-server
```

ATM Inverse ARP Configuration in a PVC Environment Example

The following example configures ATM on an interface and then configures the ATM Inverse ARP mechanism on the PVCs on the interface, with Inverse ARP datagrams sent every 5 minutes on three of the PVCs. The fourth PVC will not send Inverse ATM ARP datagrams, but will receive and respond to Inverse ATM ARP requests. For further information, refer to the related task section “Configure Classical IP and Inverse ARP in a PVC Environment” presented earlier in this chapter.

```
interface atm 0
 ip address 172.21.1.111 255.255.255.0
 atm pvc 1 1 1 aal5snap inarp 5
 atm pvc 2 2 2 aal5snap inarp 5
 atm pvc 3 3 3 aal5snap inarp 5
 atm pvc 4 4 4 aal5snap inarp
```

No **map-group** and **map-list** commands are needed for IP.

Dynamic Rate Queue Examples

Both of the following examples assume that no permanent rate queues have been configured. The software dynamically creates rate queues when an **atm pvc** command specifies a peak or average rate that does not match any user-configured rate queue. For further information, refer to the related task section “Use Dynamic Rate Queues” presented earlier in this chapter.

In the following example, the software sets the peak rate for VCD 1 to the maximum that the PLIM will allow and sets the average rate to the peak rate. Then it creates a rate queue for the peak rate of this VCD.

```
atm pvc 1 1 1 aal5snap
```

In the following example, the software creates a 100-Mbps rate queue and assigns VCD 2 to that rate queue with an average rate of 50 Mbps and a burst size of 64 cells:

```
atm pvc 2 2 2 aal5snap 100000 50000 2
```

PVC with AAL3/4 and SMDS Encapsulation Examples

The following example provides a minimal configuration of an ATM interface to support AAL3/4 and SMDS encapsulation; no protocol configuration is shown. For further information, refer to the related task section “Configure ATM Subinterfaces for SMDS Networks” presented earlier in this chapter.

```
interface atm 0
  atm smds-address c140.888.9999
  atm multicast e180.0999.9999
  atm pvc 30 0 30 aal34smds
```

The following example shows how IP dynamic routing might coexist with static routing of another protocol.

```
interface atm 0
  ip address 172.21.168.112 255.255.255.0
  atm smds-address c140.888.9999
  atm multicast e180.0999.9999
  atm pvc 30 0 30 aal34smds
  map-group atm
  appletalk address 10.1
  appletalk zone atm
  !
  map-group atm
  atalk 10.2 smds c140.8111.1111 broadcast
```

This example shows that IP configured is dynamically routed, but that AppleTalk is statically routed. An AppleTalk remote host is configured at address 10.2 and is associated with SMDS address c140.8111.1111.

AAL3/4 associates a protocol address with an SMDS address, as shown in the last line of this example. In contrast, AAL5 static maps associate a protocol address with a PVC number.

Transparent Bridging on an AAL5-SNAP PVC Example

In the following example, three AAL5-SNAP PVCs are created on the same ATM interface. The router will broadcast all spanning tree updates to these AAL5-SNAP PVCs. No other virtual circuits will receive spanning tree updates. For further information, refer to the related task section “Configure Transparent Bridging for the NPM” presented earlier in this chapter.

```
interface atm 0
  ip address 1.1.1.1 255.0.0.0
  atm pvc 1 1 1 aal5snap
  atm pvc 2 2 2 aal5snap
  atm pvc 3 3 3 aal5snap
  bridge-group 1
  !
  bridge 1 protocol dec
```

PPP-over-ATM Example

The following example configures PPP over ATM to use PPP unnumbered link and Challenge Handshake Authentication Protocol (CHAP) authentication. For further information, refer to the related task section “Configure PPP over ATM” presented earlier in this chapter.

```
configure terminal
!
interface virtual-template 2
 encapsulation ppp
 ip unnumbered ethernet 0/0
 ppp authentication chap
!
interface atm 0.2 point-to-point
!
 atm pvc 2 0 34 aal5cisco ppp 1536 1536 2 virtual-template 2
end
```

