

# Configuring LAN Emulation

---

This chapter describes how to configure LAN emulation (LANE) on the following platforms that are connected to an Asynchronous Transfer Mode (ATM) switch or switch cloud:

- ATM Interface Processor (AIP) on the Cisco 7500 series routers
- ATM port adapter on the Cisco 7200 series and Cisco 7500 series routers
- Network Processor Module (NPM) on the Cisco 4500 and Cisco 4700 routers

---

**Note** In Cisco IOS Release 11.3, all commands supported on the Cisco 7500 series routers are also supported on the Cisco 7000 series.

---

For a complete description of the LANE commands in this chapter, refer to the “LAN Emulation Commands” chapter of the *Cisco IOS Switching Services Command Reference*. To locate documentation of other commands that appear in this chapter, use the command reference master index or search online.

## LANE on ATM

LANE emulates an IEEE 802.3 Ethernet or IEEE 802.5 Token Ring LAN using ATM technology. LANE provides a service interface for network layer protocols that is identical to existing MAC layers. No changes are required to existing upper layer protocols and applications. With LANE, Ethernet and Token Ring packets are encapsulated in the appropriate ATM cells and sent across the ATM network. When the packets reach the other side of the ATM network, they are de-encapsulated. LANE essentially bridges LAN traffic across ATM switches.

## Benefits of LANE

ATM is a cell-switching and multiplexing technology designed to combine the benefits of circuit switching (constant transmission delay and guaranteed capacity) with those of packet switching (flexibility and efficiency for intermittent traffic).

LANE allows legacy Ethernet and Token Ring LAN users to take advantage of ATM’s benefits without modifying end-station hardware or software. ATM uses connection-oriented service with point-to-point signaling or multicast signaling between source and destination devices. However, LANs use connectionless service. Messages are broadcast to all devices on the network. With LANE, routers and switches emulate the connectionless service of a LAN for the endstations.

By using LANE, you can scale your networks to larger sizes while preserving your investment in LAN technology.

### LANE Components

A single emulated LAN consists of the following entities: A LANE configuration server, a broadcast-and-unknown server, a LANE server, and LANE clients.

- **LANE configuration server**—A server that assigns individual clients to particular emulated LANs by directing them to the LANE server for the emulated LAN. The LANE configuration server (LECS) maintains a database of LANE client and server ATM or MAC addresses and their emulated LANs. An LECS can serve multiple emulated LANs.
- **broadcast and unknown server**—A multicast server that floods unknown destination traffic and forwards multicast and broadcast traffic to clients within an emulated LAN. One broadcast and unknown server (BUS) exists per emulated LAN.
- **LANE server**—A server that provides a registration facility for clients to join the emulated LAN. There is one LANE server (LES) per emulated LAN. The LANE server handles LAN Emulation Address Resolution Protocol (LE ARP) requests and maintains a list of LAN destination MAC addresses. For Token Ring LANE, the LANE server also maintains a list of route-descriptors that is used to support source-route bridging over the emulated LAN. The route-descriptors are used to determine the ATM address of the next hop in the Routing Information Field (RIF).
- **LANE client**—An entity in an endpoint, such as a router, that performs data forwarding, address resolution, and other control functions for a single endpoint in a single emulated LAN. The LANE client (LEC) provides standard LAN service to any higher layers that interface with it. A router can have multiple resident LANE clients, each connecting with different emulated LANs. The LANE client registers its MAC and ATM addresses with the LANE server.

Emulated LAN entities coexist on one or more Cisco routers. On Cisco routers, the LANE server and the BUS are combined into a single entity.

Other LANE components include ATM switches—any ATM switch that supports the Interim Local Management Interface (ILMI) and signaling. Multiple emulated LANs can coexist on a single ATM network.

### Simple Server Redundancy

LANE relies on three servers: the LANE configuration server, the LANE server, and the BUS. If any one of these servers fails, the emulated LAN cannot fully function.

Cisco has developed a fault tolerance mechanism known as *simple server redundancy* that eliminates these single points of failure. Although this scheme is proprietary, no new protocol additions have been made to the LANE subsystems.

Simple server redundancy uses multiple LANE configuration servers and multiple broadcast-and-unknown and LANE servers. You can configure servers as backup servers, which will become active if a master server fails. The priority levels for the servers determine which servers have precedence.

Refer to the “Configuring Fault-Tolerant Operation” section for details and notes on the Simple Server Redundancy Protocol (SSRP).

## Implementation Considerations

The following sections contain information relevant to implementation:

- Network Support
- Hardware Support
- Addressing
- Rules for Assigning Components to Interfaces and Subinterfaces

### Network Support

In this release, Cisco supports the following networking features:

- Ethernet-emulated LANs
  - Routing from one emulated LAN to another via IP, IPX, or AppleTalk
  - Bridging between emulated LANs and between emulated LANs and other LANs
  - DECnet, Banyan VINES, and XNS routed protocols
- Token-Ring emulated LANs
  - IP routing (fast switched) between emulated LANs and between a Token Ring emulated LAN and a legacy LAN
  - IPX routing between emulated LANs and between a Token Ring emulated LAN and a legacy LAN
  - Two-port and multiport source-route bridging (fast switched) between emulated LANs and between emulated LANs and a Token Ring
  - IP and IPX multiring
  - Source-route bridging (SRB), source-route translational bridging (SR/TLB), and source-route transparent bridging (SRT)
  - AppleTalk, DECnet, Banyan VINES, and XNS protocols are not supported

Cisco's implementation of LAN Emulation over 802.5 uses existing terminology and configuration options for Token Rings, including source-route bridging. For more information about configuring source-route bridging, see the chapter "Configuring Source-Route Bridging" in the *Bridging and IBM Networking Configuration Guide*. Transparent bridging and Advanced Peer-to-Peer Networking (APPN) are not supported at this time.

- Hot Standby Router Protocol (HSRP)

For information about configuring APPN over Ethernet LANE, refer to the "Configuring APPN" chapter in the *Bridging and IBM Networking Configuration Guide*.

### Hardware Support

This release of LANE is supported on the following platforms:

- Cisco 4500-M, Cisco 4700-M
- Cisco 7200 series
- Cisco 7500 series

---

**Note** In Cisco IOS Release 11.3, all commands supported on the Cisco 7500 series routers are also supported on the Cisco 7000 series routers equipped with RSP7000. Token Ring LAN emulation on Cisco 7000 series routers requires the RSP7000 upgrade. The RSP7000 upgrade requires a minimum of 24 MB DRAM and 8 MB Flash memory.

---

The router must contain an ATM Interface Processor (AIP), ATM port adapter, or an NP-1A ATM Network Processor Module (NPM). These modules provide an ATM network interface for the routers. Network interfaces reside on modular interface processors, which provide a direct connection between the high-speed Cisco Extended Bus (CxBus) and the external networks. The maximum number of AIPs, ATM port adapters, or NPMs that the router supports depends on the bandwidth configured. The total bandwidth through all the AIPs, ATM port adapters, or NPMs in the system should be limited to 200 Mbps full duplex—two Transparent Asynchronous Transmitter/Receiver Interfaces (TAXIs), one Synchronous Optical Network (SONET) and one E3, or one SONET and one lightly used SONET.

This feature also requires one of the following switches:

- Cisco LightStream 1010 (recommended)
- Cisco LightStream 100
- Any ATM switch with UNI 3.0/3.1 and ILMI support for communicating the LECS address

TR-LANE requires Software Release 3.1(2) or later on the LightStream 100 switch and Cisco IOS Release 11.1(8) or later on the LightStream 1010.

For a complete description of the routers, switches, and interfaces, refer to your hardware documentation.

## Addressing

On a LAN, packets are addressed by the MAC-layer address of the destination and source stations. To provide similar functionality for LANE, MAC-layer addressing must be supported. Every LANE client must have a MAC address. In addition, every LANE component (server, client, broadcast-and-unknown server, and configuration server) must have an ATM address that is different from that of all the other components.

All LANE clients on the same interface have the same, automatically assigned MAC address. That MAC address is also used as the end-system identifier (ESI) part of the ATM address, as explained in the next section. Although client MAC addresses are not unique, all ATM addresses are unique.

## LANE ATM Addresses

A LANE ATM address has the same syntax as an NSAP, but it is not a network-level address. It consists of the following:

- A 13-byte prefix that includes the following fields defined by the ATM Forum:
  - AFI (Authority and Format Identifier) field (1 byte)
  - DCC (Data Country Code) or ICD (International Code Designator) field (2 bytes)
  - DFI field (Domain Specific Part Format Identifier) (1 byte)
  - Administrative Authority field (3 bytes)
  - Reserved field (2 bytes)

- Routing Domain field (2 bytes)
- Area field (2 bytes)
- A 6-byte end-system identifier (ESI)
- A 1-byte selector field

### Cisco's Method of Automatically Assigning ATM Addresses

Cisco provides the following standard method of constructing and assigning ATM and MAC addresses for use in a LANE configuration server's database. A pool of MAC addresses is assigned to each ATM interface on the router. On the Cisco 7200 series routers, Cisco 7500 series routers, Cisco 4500 routers, and Cisco 4700 routers, the pool contains eight MAC addresses. For constructing ATM addresses, the following assignments are made to the LANE components:

- The prefix fields are the same for all LANE components in the router; the prefix indicates the identity of the switch. The prefix value must be configured on the switch.
- The ESI field value assigned to every *client* on the interface is the first of the pool of MAC addresses assigned to the interface.
- The ESI field value assigned to every *server* on the interface is the second of the pool of MAC addresses.
- The ESI field value assigned to the *broadcast-and-unknown server* on the interface is the third of the pool of MAC addresses.
- The ESI field value assigned to the *configuration server* is the fourth of the pool of MAC addresses.
- The selector field value is set to the subinterface number of the LANE component—except for the LANE configuration server, which has a selector field value of 0.

Because the LANE components are defined on different subinterfaces of an ATM interface, the value of the selector field in an ATM address is different for each component. The result is a unique ATM address for each LANE component, even within the same router. For more information about assigning components to subinterfaces, see the “Rules for Assigning Components to Interfaces and Subinterfaces” section later in this chapter.

For example, if the MAC addresses assigned to an interface are 0800.200C.1000 through 0800.200C.1007, the ESI part of the ATM addresses is assigned to LANE components as follows:

- Any client gets the ESI 0800.200c.1000.
- Any server gets the ESI 0800.200c.1001.
- The broadcast-and-unknown server gets the ESI 0800.200c.1002.
- The LANE configuration server gets the ESI 0800.200c.1003.

Refer to the “Multiple Token Ring ELANs with Unrestricted Membership Example” and the “Multiple Token Ring ELANs with Restricted Membership Example” sections for examples using MAC address values as ESI field values in ATM addresses and for examples using subinterface numbers as selector field values in ATM addresses.

## Using ATM Address Templates

ATM address templates can be used in many LANE commands that assign ATM addresses to LANE components (thus overriding automatically assigned ATM addresses) or that link client ATM addresses to emulated LANs. The use of templates can greatly simplify the use of these commands. The syntax of address templates, the use of address templates, and the use of wildcard characters within an address template for LANE are very similar to those for address templates of ISO CLNS.

---

**Note** E.164-format ATM addresses do not support the use of LANE ATM address templates.

---

LANE ATM address templates can use two types of wildcards: an asterisk (\*) to match any single character, and an ellipsis (...) to match any number of leading or trailing characters.

In LANE, a *prefix template* explicitly matches the prefix but uses wildcards for the ESI and selector fields. An *ESI template* explicitly matches the ESI field but uses wildcards for the prefix and selector. Table 7 indicates how the values of unspecified digits are determined when an ATM address template is used:

**Table 7 Values of Unspecified Digits in ATM Address Templates**

Unspecified Digits In	Value Is
Prefix (first 13 bytes)	Obtained from ATM switch via Interim Local Management Interface (ILMI)
ESI (next 6 bytes)	Filled with the slot MAC address <sup>1</sup> plus <ul style="list-style-type: none"> <li>• 0—LANE client</li> <li>• 1—LANE server</li> <li>• 2—LANE broadcast-and-unknown server</li> <li>• 3—Configuration server</li> </ul>
Selector field (last 1 byte)	Subinterface number, in the range 0 through 255.

1. The lowest of the pool of MAC addresses assigned to the ATM interface plus a value that indicates the LANE component. For the Cisco 7200 series routers, Cisco 7500 series routers, Cisco 4500 routers, and Cisco 4700 routers, the pool has eight MAC addresses.

## Rules for Assigning Components to Interfaces and Subinterfaces

The following rules apply to assigning LANE components to the major ATM interface and its subinterfaces in a given router:

- The LANE configuration server always runs on the major interface.
 

The assignment of any other component to the major interface is identical to assigning that component to the 0 subinterface.
- The server and the client of the *same* emulated LAN can be configured on the same subinterface in a router.
- Clients of two *different* emulated LANs cannot be configured on the same subinterface in a router.
- Servers of two *different* emulated LANs cannot be configured on the same subinterface in a router.

## LANE Configuration Task List

Before you begin to configure LANE, you must decide whether you want to set up one or multiple emulated LANs. If you set up multiple emulated LANs, you must also decide where the servers and clients will be located, and whether to restrict the clients that can belong to each emulated LAN. Bridged emulated LANs are configured just like any other LAN, in terms of commands and outputs. Once you have made those basic decisions, you can proceed to configure LANE.

To configure LANE, complete the tasks in the following sections:

- Create a LANE Plan and Worksheet
- Configure the Prefix on the Switch
- Set Up the Signaling and ILMI PVCs
- Display LANE Default Addresses
- Enter the Configuration Server's ATM Address on the Cisco Switch
- Set Up the Configuration Server's Database
- Enable the Configuration Server
- Set Up LANE Servers and Clients

While the above sections contains information about configuring SSRP fault tolerance, refer to the following section for detailed information about requirements and implementation considerations:

- Configure Fault-Tolerant Operation

Once LANE is configured, you can monitor and maintain the components in the participating routers by completing the tasks in the following section:

- Monitor and Maintain the LANE Components

For configuration examples, see the "LANE Configuration Examples" section at the end of this chapter.

## Create a LANE Plan and Worksheet

It might help you to begin by drawing up a plan and a worksheet for your own LANE scenario, showing the following information and leaving space for noting the ATM address of each of the LANE components on each subinterface of each participating router:

- The router and interface where the LANE configuration server will be located
- The router, interface, and subinterface where the LANE server and broadcast-and-unknown server for each emulated LAN will be located. There can be multiple servers for each emulated LAN for fault-tolerant operation.
- The routers, interfaces, and subinterfaces where the clients for each emulated LAN will be located
- The name of the default emulated LAN (optional)
- The names of the emulated LANs that will have unrestricted membership
- The names of the emulated LANs that will have restricted membership

The last three items in this list are very important; they determine how you set up each emulated LAN in the configuration server's database.

## Configure the Prefix on the Switch

Before you configure LANE components on any Cisco 7200 series router, Cisco 7500 series router, Cisco 4500 router, or Cisco 4700 router, you must configure the Cisco ATM switch with the ATM address prefix to be used by all LANE components in the switch cloud. On the Cisco switch, the ATM address prefix is called the node ID. Prefixes must be 26 digits long. If you provide fewer than 26 digits, zeros are added to the right of the specified value to fill it to 26 digits.

To set the ATM address prefix on the Cisco LightStream 1010, complete the following tasks on the Cisco switch, starting in global configuration mode:

Task	Command
Set the local node ID (prefix of the ATM address).	<b>atm address</b> { <i>atm-address</i>   <i>prefix...</i> }
Exit global configuration mode,	<b>exit</b>
Save the configuration values permanently.	<b>copy running-config startup-config</b>

To set the ATM address prefix on the Cisco LightStream 100, complete the following tasks on the Cisco switch:

Task	Command
Set the local node ID (prefix of the ATM address).	<b>set local name</b> <i>ip-address mask prefix</i>
Save the configuration values permanently.	<b>save</b>

On the Cisco switches, you can display the current prefix by using the **show network** command.

---

**Note** If you do not save the configured value permanently, it will be lost when the switch is reset or powered off.

---

## Set Up the Signaling and ILMI PVCs

You must set up the signaling permanent virtual circuit (PVC) and the PVC that will communicate with the ILMI on the major ATM interface of any router that participates in LANE.

Complete this task only once for a major interface. You do not need to repeat this task on the same interface even though you might configure LANE servers and clients on several of its subinterfaces.

To set up these PVCs, complete the following steps, beginning in global configuration mode:

Task	Command
<b>Step 1</b> Specify the major ATM interface and enter interface configuration mode. <ul style="list-style-type: none"> <li>• On the AIP for Cisco 7500 series routers; On the ATM port adapter for Cisco 7200 series routers.</li> <li>• On the ATM port adapter for Cisco 7500 series routers.</li> <li>• On the NPM for Cisco 4500 and Cisco 4700 routers.</li> </ul>	<b>interface atm</b> <i>slot</i> <b>0</b> <b>interface atm</b> <i>slot</i> / <i>port-adapter</i> <b>0</b> <b>interface atm</b> <i>number</i>
<b>Step 2</b> Set up the signaling PVC that sets up and tears down switched virtual circuits (SVCs); the <i>vpi</i> and <i>vci</i> values are usually set to 0 and 5, respectively.	<b>atm pvc</b> <i>vcd vpi vci</i> <b>qsaal</b>
<b>Step 3</b> Set up a PVC to communicate with the ILMI; the <i>vpi</i> and <i>vci</i> values are usually set to 0 and 16, respectively.	<b>atm pvc</b> <i>vcd vpi vci</i> <b>ilmi</b>

## Display LANE Default Addresses

You can display the LANE default addresses to make configuration easier. Complete this task for each router that participates in LANE. This command displays default addresses for all ATM interfaces present on the router. Write down the displayed addresses on your worksheet.

To display the default LANE addresses, perform the following task in global configuration mode:

Task	Command
Display the LANE default addresses.	<b>show lane default-atm-addresses</b>

## Enter the Configuration Server's ATM Address on the Cisco Switch

You must enter the configuration server's ATM address into the Cisco LightStream 100 or Cisco Lightstream 1010 ATM switch and save it permanently so that the value is not lost when the switch is reset or powered off.

You must specify the full 40-digit ATM address. Use the addresses on your worksheet that you obtained from the previous task.

If you are configuring Simple Server Redundancy Protocol (SSRP), enter the multiple LANE configuration server addresses into the end ATM switches. The switches are used as central locations for the list of LANE configuration server addresses. LANE components connected to the switches obtain the global list of LANE configuration server addresses from the switches.

Depending on which type of switch you are using, perform one of the following tasks:

- Enter the ATM Address(es) on the Cisco LightStream 1010 ATM Switch
- Enter the ATM Address(es) on the Cisco LightStream 100 ATM Switch

## Enter the ATM Address(es) on the Cisco LightStream 1010 ATM Switch

On the Cisco LightStream 1010 ATM switch, the configuration server address can be specified for a port or for the entire switch.

To enter the configuration server addresses on the Cisco LightStream 1010 ATM switch for the entire switch, perform the following tasks beginning in global configuration mode:

Task	Command
<b>Step 1</b> Specify the LANE configuration server's ATM address for the entire switch. If you are configuring SSRP, include the ATM addresses of all the LANE configuration servers.	<b>atm lecs-address-default lecsaddress [sequence #]</b> <sup>1</sup>
<b>Step 2</b> Exit global configuration mode.	<b>exit</b>
<b>Step 3</b> Save the configuration value permanently.	<b>copy running-config startup-config</b>

1. Refer to the *LightStream 1010 ATM Switch Command Reference* for further information about this command.

## Set Up the Configuration Server's Database

---

To enter the configuration server addresses on the Cisco LightStream 1010 ATM switch per port, perform the following tasks beginning in interface configuration mode:

Task	Command
<b>Step 1</b> Specify the LANE configuration server's ATM address for a port. If you are configuring SSRP, include the ATM addresses of all the LANE configuration servers.	<b>atm lecs-address</b> <i>lecsaddress</i> [ <i>sequence #</i> ] <sup>1</sup>
<b>Step 2</b> Exit interface configuration mode.	<b>Ctrl-Z</b>
<b>Step 3</b> Save the configuration value permanently.	<b>copy running-config startup-config</b>

1. Refer to the *LightStream 1010 ATM Switch Command Reference* for further information about this command.

## Enter the ATM Address(es) on the Cisco LightStream 100 ATM Switch

To enter the configuration server's ATM address into the Cisco LightStream 100 ATM switch and save it permanently, perform the following tasks in privileged EXEC mode:

Task	Command
<b>Step 1</b> Specify the LANE configuration server's ATM address. If you are configuring SSRP, repeat this command for each configuration server address. The <i>index</i> value determines the priority. The highest priority is 0. There can be a maximum of 4 LANE configuration servers.	<b>set configserver</b> <i>index atm-address</i>
<b>Step 2</b> Save the configuration value permanently.	<b>save</b>

## Set Up the Configuration Server's Database

The configuration server's database contains information about each emulated LAN, including the ATM addresses of the LANE servers.

You can specify one default emulated LAN in the database. The LANE configuration server will assign any client that does not request a specific emulated LAN to the default emulated LAN.

Emulated LANs are either restricted or unrestricted. The configuration server will assign a client to an unrestricted emulated LAN if the client specifies that particular emulated LAN in its configuration. However, the configuration server will only assign a client to a restricted emulated LAN if the client is specified in the configuration server's database as belonging to that emulated LAN. The default emulated LAN must have unrestricted membership.

If you are configuring fault tolerance, you can have any number of servers per emulated LAN. Priority is determined by entry order; the first entry has the highest priority, unless you override it with the *index* option.

To set up the database, complete the tasks in the following sections as appropriate for your emulated LAN plan and scenario:

- Set Up the Database for the Default Emulated LAN Only
- Set Up the Database for Unrestricted-Membership Emulated LANs
- Set Up the Database for Restricted-Membership LANs

## Set Up the Database for the Default Emulated LAN Only

When you configure a router as the configuration server for one default emulated LAN, you provide a name for the database, the ATM address of the LANE server for the emulated LAN, and a default name for the emulated LAN. In addition, you indicate that the configuration server's ATM address is to be computed automatically.

When you configure a database with only a default unrestricted emulated LAN, you do not have to specify where the LANE clients are located. That is, when you set up the configuration server's database for a single default emulated LAN, you do not have to provide any database entries that link the ATM addresses of any clients with the emulated LAN name. All of the clients will be assigned to the default emulated LAN.

To set up the configuration server for the default emulated LAN, complete the following tasks beginning in global configuration mode:

Task	Commands
<b>Step 1</b> Create a named database for the LANE configuration server.	<b>lane database</b> <i>database-name</i>
<b>Step 2</b> In the configuration database, bind the name of the emulated LAN to the ATM address of the LANE server.  If you are configuring SSRP, repeat this step for each additional server for the same emulated LAN. The index determines the priority. The highest priority is 0.	<b>name</b> <i>elan-name</i> <b>server-atm-address</b> <i>atm-address</i> <b>[index number]</b>
<b>Step 3</b> If you are configuring a Token Ring emulated LAN, assign a segment number to the emulated Token Ring LAN in the configuration database.	<b>name</b> <i>elan-name</i> <b>local-seg-id</b> <i>segment-number</i>
<b>Step 4</b> In the configuration database, provide a default name for the emulated LAN.	<b>default-name</b> <i>elan-name</i>
<b>Step 5</b> Exit from database configuration mode and return to global configuration mode.	<b>exit</b>

In Step 2, enter the ATM address of the server for the specified emulated LAN, as noted in your worksheet and obtained in the "Display LANE Default Addresses" section.

You can have any number of servers per emulated LAN for fault tolerance. Priority is determined by entry order. The first entry has the highest priority unless you override it with the index option.

If you are setting up only a default emulated LAN, the *elan-name* value in Steps 2 and 3 is the same as the default emulated LAN name you provide in Step 4.

To set up fault-tolerant operation, see the "Configure Fault-Tolerant Operation" section later in this chapter.

## Set Up the Database for Unrestricted-Membership Emulated LANs

When you set up a database for unrestricted emulated LANs, you create database entries that link the name of each emulated LAN to the ATM address of its server.

## Set Up the Configuration Server's Database

---

However, you may choose not to specify where the LANE clients are located. That is, when you set up the configuration server's database, you do not have to provide any database entries that link the ATM addresses or MAC addresses of any clients with the emulated LAN name. The configuration server will assign the clients to the emulated LANs specified in the client's configurations.

To configure a router as the configuration server for multiple emulated LANs with unrestricted membership, perform the following tasks beginning in global configuration mode:

Task	Command
<b>Step 1</b> Create a named database for the LANE configuration server.	<b>lane database</b> <i>database-name</i>
<b>Step 2</b> In the configuration database, bind the name of the first emulated LAN to the ATM address of the LANE server for that emulated LAN.  If you are configuring SSRP, repeat this step with the same emulated LAN name but with different server ATM addresses for each additional server for the same emulated LAN. The index determines the priority. The highest priority is 0.	<b>name</b> <i>elan-name1</i> <b>server-atm-address</b> <i>atm-address</i> [ <b>index</b> <i>number</i> ]
<b>Step 3</b> In the configuration database, bind the name of the second emulated LAN to the ATM address of the LANE server.  If you are configuring SSRP, repeat this step with the same emulated LAN name but with different server ATM addresses for each additional server for the same emulated LAN. The index determines the priority. The highest priority is 0.  Repeat this step, providing a different emulated LAN name and ATM address for each additional emulated LAN in this switch cloud.	<b>name</b> <i>elan-name2</i> <b>server-atm-address</b> <i>atm-address</i> [ <b>index</b> <i>number</i> ]
<b>Step 4</b> For a Token Ring emulated LAN, assign a segment number to the first emulated Token Ring LAN in the configuration database.	<b>name</b> <i>elan-name1</i> <b>local-seg-id</b> <i>segment-number</i>
<b>Step 5</b> For Token Ring emulated LANs, assign a segment number to the second emulated Token Ring LAN in the configuration database.  Repeat this step, providing a different emulated LAN name and segment number for each additional source-route bridged emulated LAN in this switch cloud.	<b>name</b> <i>elan-name2</i> <b>local-seg-id</b> <i>segment-number</i>
<b>Step 6</b> (Optional) Specify a default emulated LAN for LANE clients not explicitly bound to an emulated LAN.	<b>default-name</b> <i>elan-name1</i>
<b>Step 7</b> Exit from database configuration mode and return to global configuration mode.	<b>exit</b>

In the preceding steps, enter the ATM address of the server for the specified emulated LAN, as noted in your worksheet and obtained in the “Display LANE Default Addresses” section.

To set up fault-tolerant operation, see the “Configure Fault-Tolerant Operation” section later in this chapter.

## Set Up the Database for Restricted-Membership LANs

When you set up the database for restricted-membership emulated LANs, you create database entries that link the name of each emulated LAN to the ATM address of its server.

However, you must also specify where the LANE clients are located. That is, for each restricted-membership emulated LAN, you provide a database entry that explicitly links the ATM address or MAC address of each client of that emulated LAN with the name of that emulated LAN.

The client database entries specify which clients are allowed to join the emulated LAN. When a client requests to join an emulated LAN, the configuration server consults its database and then assigns the client to the emulated LAN specified in the configuration server's database.

When clients for the same restricted-membership emulated LAN are located in multiple routers, each client's ATM address or MAC address must be linked explicitly with the name of the emulated LAN. As a result, you must configure as many client entries (at Steps 6 and 7, in the following procedure) as you have clients for emulated LANs in all the routers. Each client will have a different ATM address in the database entries.

To set up the configuration server for emulated LANs with restricted membership, perform the following tasks beginning in global configuration mode:

Task	Command
<b>Step 1</b> Create a named database for the LANE configuration server.	<b>lane database</b> <i>database-name</i>
<b>Step 2</b> In the configuration database, bind the name of the first emulated LAN to the ATM address of the LANE server for that emulated LAN.  If you are configuring SSRP, repeat this step with the same emulated LAN name but with different server ATM addresses for each additional server for the same emulated LAN. The index determines the priority. The highest priority is 0.	<b>name</b> <i>elan-name1</i> <b>server-atm-address</b> <i>atm-address</i> <b>restricted</b> [ <i>index number</i> ]
<b>Step 3</b> In the configuration database, bind the name of the second emulated LAN to the ATM address of the LANE server.  If you are configuring SSRP, repeat this step with the same emulated LAN name but with different server ATM addresses for each additional server for the same emulated LAN. The index determines the priority. The highest priority is 0.  Repeat this step, providing a different name and a different ATM address, for each additional emulated LAN.	<b>name</b> <i>elan-name2</i> <b>server-atm-address</b> <i>atm-address</i> <b>restricted</b> [ <i>index number</i> ]
<b>Step 4</b> For a Token Ring emulated LAN, assign a segment number to the first emulated Token Ring LAN in the configuration database.	<b>name</b> <i>elan-name1</i> <b>local-seg-id</b> <i>segment-number</i>

## Enable the Configuration Server

---

<b>Step 5</b>	If you are configuring Token Ring emulated LANs, assign a segment number to the second emulated Token Ring LAN in the configuration database.  Repeat this step, providing a different emulated LAN name and segment number for each additional source-route bridged emulated LAN in this switch cloud.	<b>name</b> <i>elan-name2</i> <b>local-seg-id</b> <i>segment-number</i>
<b>Step 6</b>	Add a database entry associating a specific client's ATM address with the first restricted-membership emulated LAN.  Repeat this step for each of the clients of the first restricted-membership emulated LAN.	<b>client-atm-address</b> <i>atm-address-template</i> <b>name</b> <i>elan-name1</i>
<b>Step 7</b>	Add a database entry associating a specific client's ATM address with the second restricted-membership emulated LAN.  Repeat this step for each of the clients of the second restricted-membership emulated LAN.  Repeat this step, providing a different name and a different list of client ATM address, for each additional emulated LAN.	<b>client-atm-address</b> <i>atm-address-template</i> <b>name</b> <i>elan-name2</i>
<b>Step 8</b>	Exit from database configuration mode and return to global configuration mode.	<b>exit</b>

To set up fault-tolerant operation, see the “Configure Fault-Tolerant Operation” section later in this chapter.

## Enable the Configuration Server

Once you have created the database, you can enable the configuration server on the selected ATM interface and router by completing the following tasks, beginning in global configuration mode:

Task	Command
<b>Step 1</b>	If you are not currently configuring the interface, specify the major ATM interface where the configuration server is located. <ul style="list-style-type: none"><li>• On the AIP for Cisco 7500 series routers; On the ATM port adapter for Cisco 7200 series routers. <b>interface atm slot/0[.subinterface-number]</b></li><li>• On the ATM port adapter for Cisco 7500 series routers. <b>interface atm slot/port-adapter/0[.subinterface-number]</b></li><li>• On the NPM for Cisco 4500 and Cisco 4700 routers. <b>interface atm number[.subinterface-number]</b></li></ul>
<b>Step 2</b>	Link the configuration server's database name to the specified major interface, and enable the configuration server. <b>lane config database database-name</b>

Task	Command
<b>Step 3</b> Specify how the LECS's ATM address will be computed. You may opt to choose one of the following scenarios: <ul style="list-style-type: none"> <li>• The LECS will participate in SSRP and the address is computed by the automatic method.</li> <li>• The LECS will participate in SSRP, and the address is computed by the automatic method. If the LECS is the master, the fixed address is also used.</li> <li>• The LECS will not participate in SSRP, the LECS is the master, and only the well-known address is used.</li> <li>• The LECS will participate in SSRP and the address is computed using an explicit, 20-byte ATM address.</li> </ul>	<b>lane config auto-config-atm-address</b>  <b>lane config auto-config-atm-address</b> <b>lane config fixed-config-atm-address</b>  <b>lane config fixed-config-atm-address</b>  <b>lane config config-atm-address <i>atm-address-template</i></b>
<b>Step 4</b> Exit interface configuration mode.	<b>exit</b>
<b>Step 5</b> Return to EXEC mode.	<b>Ctrl-Z</b>
<b>Step 6</b> Save the configuration.	<b>copy running-config startup-config</b>

## Set Up LANE Servers and Clients

For each router that will participate in LANE, set up the necessary servers and clients for each emulated LAN; then display and record the server and client ATM addresses. Be sure to keep track of the router interface where the LANE configuration server will eventually be located.

You can set up servers for more than one emulated LAN on different subinterfaces or on the same interface of a router, or you can place the servers on different routers.

When you set up a server and broadcast-and-unknown server on a router, you can combine them with a client on the same subinterface, a client on a different subinterface, or no client at all on the router.

Where you put the clients is important because any router with clients for multiple emulated LANs can route frames between those emulated LANs.

Depending on where your clients and servers are located, perform one of the following tasks for each LANE subinterface.

- Set Up the Server, Broadcast-and-Unknown Server, and a Client on a Subinterface
- Set Up Only a Client on a Subinterface

## Set Up the Server, Broadcast-and-Unknown Server, and a Client on a Subinterface

To set up the server, broadcast-and-unknown server, and (optionally) clients for an emulated LAN, perform the following tasks beginning in global configuration mode:

Task	Command
<b>Step 1</b> Specify the subinterface for the emulated LAN on this router. <ul style="list-style-type: none"> <li>On the AIP for Cisco 7500 series routers; On the ATM port adapter for Cisco 7200 series routers.</li> <li>On the ATM port adapter for Cisco 7500 series routers.</li> <li>On the NPM for Cisco 4500 and Cisco 4700 routers.</li> </ul>	<b>interface atm</b> <i>slot</i> <b>0.subinterface-number</b>  <b>interface atm</b> <i>slot</i> / <i>port-adapter</i> <b>0.subinterface-number</b>  <b>interface atm</b> <i>number.subinterface-number</i>
<b>Step 2</b> Enable a LANE server and a LANE broadcast-and-unknown server for the emulated LAN.	<b>lane server-bus</b> { <b>ethernet</b>   <b>tokenring</b> } <i>elan-name</i>
<b>Step 3</b> (Optional) Enable a LANE client for the emulated LAN.	<b>lane client</b> { <b>ethernet</b>   <b>tokenring</b> } [ <i>elan-name</i> ]
<b>Step 4</b> Provide a protocol address for the client.	<b>ip</b> <i>address mask</i> <sup>1</sup>
<b>Step 5</b> Return to EXEC mode.	<b>Ctrl-Z</b>
<b>Step 6</b> Save the configuration.	<b>copy running-config startup-config</b>

1. The command or commands depend on the routing protocol used. If you are using IPX or AppleTalk, see the relevant protocol chapter (IPX or AppleTalk) in the *Network Protocols Command Reference, Part 2* for the commands to use.

If the emulated LAN in Step 3 is intended to have *restricted membership*, consider carefully whether you want to specify its name here. You will specify the name in the LANE configuration server's database when it is set up. However, if you link the client to an emulated LAN in this step, and through some mistake it does not match the database entry linking the client to an emulated LAN, this client will not be allowed to join this emulated LAN or any other.

If you do decide to include the name of the emulated LAN linked to the client in Step 3 and later want to associate that client with a different emulated LAN, make the change in the configuration server's database before you make the change for the client on this subinterface.

Each emulated LAN is a separate subnetwork. In Step 4 make sure that the clients of the same emulated LAN are assigned protocol addresses on the same subnetwork and that clients of different emulated LANs are assigned protocol addresses on different subnetworks.

## Set Up Only a Client on a Subinterface

On any given router, you can set up one client for one emulated LAN or multiple clients for multiple emulated LANs. You can set up a client for a given emulated LAN on any routers you choose to participate in that emulated LAN. Any router with clients for multiple emulated LANs can route packets between those emulated LANs.

You must first set up the signaling and ILMI PVCs on the major ATM interface, as described earlier in the "Set Up the Signaling and ILMI PVCs" section, before you set up the client.

To set up only a client for an emulated LANs, perform the following tasks beginning in interface configuration mode:

Task	Command
<b>Step 1</b> Specify the subinterface for the emulated LAN on this router. <ul style="list-style-type: none"> <li>• On the AIP for Cisco 7500 series routers; On the ATM port adapter for Cisco 7200 series routers.</li> <li>• On the ATM port adapter for Cisco 7500 series routers.</li> <li>• On the NPM for Cisco 4500 and Cisco 4700 routers.</li> </ul>	<b>interface atm slot/0.subinterface-number</b>  <b>interface atm slot/port-adapter/0.subinterface-number</b>  <b>interface atm number.subinterface-number</b>
<b>Step 2</b> Provide a protocol address for the client on this subinterface.	<b>ip address mask<sup>1</sup></b>
<b>Step 3</b> Enable a LANE client for the emulated LAN.	<b>lane client {ethernet   tokenring} [elan-name]</b>
<b>Step 4</b> Return to EXEC mode.	<b>Ctrl-Z</b>
<b>Step 5</b> Save the configuration.	<b>copy running-config startup-config</b>

1. The command or commands depend on the routing protocol used. If you are using IPX or AppleTalk, see the relevant protocol chapter (IPX or AppleTalk) in the *Network Protocols Command Reference, Part 2* for the commands to use.

Each emulated LAN is a separate subnetwork. In Step 2, make sure that the clients of the same emulated LAN are assigned protocol addresses on the same subnetwork and that clients of different emulated LANs are assigned protocol addresses on different subnetworks.

## Configure Fault-Tolerant Operation

The LANE simple server redundancy feature creates fault tolerance using standard LANE protocols and mechanisms. If a failure occurs on the LANE configuration server or on the LANE server/broadcast-and-unknown server, the emulated LAN can continue to operate using the services of a backup LANE server. This protocol is called the Simple Server Redundancy Protocol (SSRP).

This section describes how to configure simple server redundancy for fault tolerance on an emulated LAN.

---

**Note** This server redundancy does not overcome other points of failure beyond the router ports: Additional redundancy on the LAN side or in the ATM switch cloud are not a part of the LANE simple server redundancy feature.

---

### Simple Server Redundancy Requirements

For simple LANE service replication or fault tolerance to work, the ATM switch must support multiple LANE server addresses. This mechanism is specified in the LANE standard. The LANE servers establish and maintain a standard control circuit that enables the server redundancy to operate.

LANE simple server redundancy is supported on Cisco IOS Release 11.2 and later software. Older LANE configuration files continue to work with this new software.

This redundancy feature works only with Cisco LANE configuration servers and LANE server/broadcast-and-unknown server combinations. Third-party LANE Clients can be used with the SSRP, but third-party configuration servers, LANE servers, and broadcast-and-unknown servers do not support SSRP.

For server redundancy to work correctly:

- All the ATM switches must have identical lists of the global LANE configuration server addresses, in the identical priority order.
- The operating LANE configuration servers must use exactly the same configuration database. Load the configuration table data using the **copy {rcp | tftp} running-config** command. This method minimizes errors and enables the database to be maintained centrally in one place.

The LANE protocol does not specify where any of the emulated LAN server entities should be located, but for the purpose of reliability and performance, Cisco implements these server components on its routers.

### Redundant Configuration Servers

To enable redundant LANE configuration servers, enter the multiple LANE configuration server addresses into the end ATM switches. LANE components can obtain the list of LANE configuration server addresses from the ATM switches through the Interim Local Management Interface (ILMI).

Refer to the “Enter the Configuration Server’s ATM Address on the Cisco Switch” section for more details.

### Redundant Servers and Broadcast-and-Unknown Servers

The LANE configuration server turns on server/broadcast-and-unknown server redundancy by adjusting its database to accommodate multiple server ATM addresses for a particular emulated LAN. The additional servers serve as backup servers for that emulated LAN.

To activate the feature, you add an entry for the hierarchical list of servers that will support the given emulated LAN. All database modifications for the emulated LAN must be identical on all LANE configuration servers.

Refer to the “Set Up the Configuration Server’s Database” section for more details.

### Implementation Considerations

- The LightStream 1010 can handle up to 16 LANE configuration server addresses. The LightStream 100 allows a maximum of 4 LANE configuration server addresses.
- There is no limit on the number of LANE servers that can be defined per emulated LAN.
- When a LANE configuration server switchover occurs, no previously joined clients are affected.
- When a LANE server/broadcast-and-unknown server switches over, momentary loss of clients occurs until they are all transferred to the new LANE server/broadcast-and-unknown server.
- LANE configuration servers come up as masters until a higher-level LANE configuration server tells them otherwise. This is automatic and cannot be changed.
- If a higher-priority LANE server comes online, it bumps the current LANE server off on the same emulated LAN. Therefore, there may be some flapping of clients from one LANE server to another after a powerup, depending on the order of the LANE servers coming up. Flapping should settle after the *last* highest-priority LANE server comes up.

- If none of the specified LANE servers are up or connected to the master LANE configuration server and more than one LANE server is defined for an emulated LAN, a configuration request for that specific emulated LAN is rejected by the LANE configuration server.
- Changes made to the list of LANE configuration server addresses on ATM switches may take up to a minute to propagate through the network. Changes made to the configuration database regarding LANE server addresses take effect almost immediately.
- If none of the designated LANE configuration servers are operational or reachable, the ATM Forum-defined well-known LANE configuration server address is used.
- You can override the LANE configuration server address on any subinterface, by using the following commands:
  - **lane auto-config-atm-address**
  - **lane fixed-config-atm-address**
  - **lane config-atm-address**



**Caution** When an override like this is performed, fault-tolerant operation cannot be guaranteed. To avoid affecting the fault-tolerant operation, do not override any LANE configuration server, LANE server or broadcast-and-unknown server addresses.

- If an underlying ATM network failure occurs, there may be multiple master LANE configuration servers and multiple active LANE servers for the same emulated LAN. This situation creates a “partitioned” network. The clients continue to operate normally, but transmission between different partitions of the network is not possible. When the network break is repaired, the system recovers.
- When the LECS is already up and running, and you use the **lane config fixed-config-atm-address** command to configure the well-known LECS address, please be aware of the following scenarios:
  - If you configure the LECS with only the well-known address, the LECS will not participate in the SSRP, act as a “standalone” master, and only listen on the well-known LECS address. This scenario is ideal if you want a “standalone” LECS that does not participate in SSRP, and you would like to listen to only the well-known address.
  - If only the well-known address is already assigned, and you assign at least one other address to the LECS, (additional addresses are assigned using the **lane config auto-config-atm-address** command and/or the **lane config config-atm-address command**) the LECS will participate in the SSRP and act as the master or slave based on the normal SSRP rules. This scenario is ideal if you would like the LECS to participate in SSRP, and you would like to make the master LECS listen on the well-known address.
  - If the LECS is participating in SSRP, has more than one address (one of which is the well-known address), and all the addresses but the well-known address is removed, the LECS will declare itself the master and stop participating in SSRP completely.
  - If the LECS is operating as an SSRP slave, and it has the well-known address configured, it will not listen on the well-known address unless it becomes the master.
  - If you want the LECS to assume the well-known address only when it becomes the master, configure the LECS with the well-known address and at least one other address.

## Monitor and Maintain the LANE Components

After configuring LANE components on an interface or any of its subinterfaces, on a specified subinterface, or on an emulated LAN, you can display their status. To show LANE information, perform the following tasks in EXEC mode:

Task	Command
<p>Display the global and per-virtual channel connection LANE information for all the LANE components and emulated LANs configured on an interface or any of its subinterfaces.</p> <ul style="list-style-type: none"> <li>On the AIP for Cisco 7500 series routers; On the ATM port adapter for Cisco 7200 series routers.</li> <li>On the ATM port adapter for Cisco 7500 series routers.</li> <li>On the NPM for Cisco 4500 and Cisco 4700 routers.</li> </ul>	<p><b>show lane</b> [<b>interface atm slot/0</b> [.subinterface-number]   <b>name elan-name</b>] [<b>brief</b>]</p> <p><b>show lane</b> [<b>interface atm slot/port-adapter/0</b> [.subinterface-number]   <b>name elan-name</b>] [<b>brief</b>]</p> <p><b>show lane</b> [<b>interface atm number</b> [.subinterface-number]   <b>name elan-name</b>] [<b>brief</b>]</p>
<p>Display the global and per-VCC LANE information for the broadcast-and-unknown server configured on any subinterface or emulated LAN.</p> <ul style="list-style-type: none"> <li>On the AIP for Cisco 7500 series routers; On the ATM port adapter for Cisco 7200 series routers.</li> <li>On the ATM port adapter for Cisco 7500 series routers.</li> <li>On the NPM for Cisco 4500 and Cisco 4700 routers.</li> </ul>	<p><b>show lane bus</b> [<b>interface atm slot/0</b> [.subinterface-number]   <b>name elan-name</b>] [<b>brief</b>]</p> <p><b>show lane bus</b> [<b>interface atm slot/port-adapter/ 0</b> [.subinterface-number]   <b>name elan-name</b>] [<b>brief</b>]</p> <p><b>show lane bus</b> [<b>interface atm number</b> [.subinterface-number]   <b>name elan-name</b>] [<b>brief</b>]</p>
<p>Display the global and per-VCC LANE information for all LANE clients configured on any subinterface or emulated LAN.</p> <ul style="list-style-type: none"> <li>On the AIP for Cisco 7500 series routers; On the ATM port adapter for Cisco 7200 series routers.</li> <li>On the ATM port adapter for Cisco 7500 series routers.</li> <li>On the NPM for Cisco 4500 and Cisco 4700 routers.</li> </ul>	<p><b>show lane client</b> [<b>interface atm slot/0</b> [.subinterface-number]   <b>name elan-name</b>] [<b>brief</b>]</p> <p><b>show lane client</b> [<b>interface atm slot/port-adapter/0</b> [.subinterface-number]   <b>name elan-name</b>] [<b>brief</b>]</p> <p><b>show lane client</b> [<b>interface atm number</b> [.subinterface-number]   <b>name elan-name</b>] [<b>brief</b>]</p>

Task	Command
Display the global and per-VCC LANE information for the configuration server configured on any interface.	<ul style="list-style-type: none"> <li>On the AIP for Cisco 7500 series routers; On the ATM port adapter for Cisco 7200 series routers.                              <b>show lane config [interface atm slot/0]</b> </li> <li>On the ATM port adapter for Cisco 7500 series routers.                              <b>show lane config [interface atm slot/port-adapter/0]</b> </li> <li>On the NPM for Cisco 4500 and Cisco 4700 routers.                              <b>show lane config [interface atm number]</b> </li> </ul>
Display the LANE configuration server's database.	<b>show lane database [database-name]</b>
Display the automatically assigned ATM address of each LANE component in a router or on a specified interface or subinterface.	<ul style="list-style-type: none"> <li>On the AIP for Cisco 7500 series routers; On the ATM port adapter for Cisco 7200 series routers.                              <b>show lane default-atm-addresses [interface atm slot/0.subinterface-number]</b> </li> <li>On the ATM port adapter for Cisco 7500 series routers.                              <b>show lane default-atm-addresses [interface atm slot/port-adapter/0.subinterface-number]</b> </li> <li>On the NPM for Cisco 4500 and Cisco 4700 routers.                              <b>show lane default-atm-addresses [interface atm number.subinterface-number]</b> </li> </ul>
Display the LANE ARP table of the LANE client configured on the specified subinterface or emulated LAN.	<ul style="list-style-type: none"> <li>On the AIP for Cisco 7500 series routers; On the ATM port adapter for Cisco 7200 series routers.                              <b>show lane le-arp [interface atm slot/0[.subinterface-number]   name elan-name]</b> </li> <li>On the ATM port adapter for Cisco 7500 series routers.                              <b>show lane le-arp [interface atm slot/port-adapter/0[.subinterface-number]   name elan-name]</b> </li> <li>On the NPM for Cisco 4500 and Cisco 4700 routers.                              <b>show lane le-arp [interface atm number[.subinterface-number]   name elan-name]</b> </li> </ul>
Display the global and per-VCC LANE information for the LANE server configured on a specified subinterface or emulated LAN.	<ul style="list-style-type: none"> <li>On the AIP for Cisco 7500 series routers; On the ATM port adapter for Cisco 7200 series routers.                              <b>show lane server [interface atm slot/0[.subinterface-number]   name elan-name] [brief]</b> </li> <li>On the ATM port adapter for Cisco 7500 series routers.                              <b>show lane server [interface atm slot/port-adapter/0[.subinterface-number]   name elan-name] [brief]</b> </li> <li>On the NPM for Cisco 4500 and Cisco 4700 routers.                              <b>show lane server [interface atm number[.subinterface-number]   name elan-name] [brief]</b> </li> </ul>

# LANE Configuration Examples

The examples in the following sections illustrate how to configure LANE for the following cases:

- Default Configuration for a Single Ethernet Emulated LAN Example
- Default Configuration for a Single Ethernet Emulated LAN with a Backup LANE Configuration Server and LANE Server Example
- Multiple Token Ring ELANs with Unrestricted Membership Example
- Multiple Token Ring ELANs with Restricted Membership Example
- TR-LANE with 2-Port Source-Route Bridging Example
- TR-LANE with Multiport Source-Route Bridging Example
- Routing between Token Ring and Ethernet Emulated LANs Example

All examples use the automatic ATM address assignment method described in the “Cisco’s Method of Automatically Assigning ATM Addresses” section earlier in this chapter. These examples show the LANE configurations, not the process of determining the ATM addresses and entering them.

## Default Configuration for a Single Ethernet Emulated LAN Example

The following example configures four Cisco 7500 series routers for one Ethernet emulated LAN. Router 1 contains the configuration server, the server, the broadcast-and-unknown server, and a client. The remaining routers each contain a client for the emulated LAN. This example accepts all default settings that are provided. For example, it does not explicitly set ATM addresses for the different LANE components that are colocated on the router. Membership in this LAN is not restricted.

### Router 1

```
lane database example1
name eng server-atm-address 39.000001415555121101020304.0800.200c.1001.01
default-name eng
interface atm 1/0
  atm pvc 1 0 5 qsaal
  atm pvc 2 0 16 ilmi
  lane config auto-config-atm-address
  lane config database example1
interface atm 1/0.1
  ip address 172.16.0.1 255.255.255.0
  lane server-bus ethernet eng
  lane client ethernet
```

### Router 2

```
interface atm 1/0
  atm pvc 1 0 5 qsaal
  atm pvc 2 0 16 ilmi
interface atm 1/0.1
  ip address 172.16.0.3 255.255.255.0
  lane client ethernet
```

**Router 3**

```
interface atm 2/0
  atm pvc 1 0 5 qsaal
  atm pvc 2 0 16 ilmi
interface atm 2/0.1
  ip address 172.16.0.4 255.255.255.0
  lane client ethernet
```

**Router 4**

```
interface atm 1/0
  atm pvc 1 0 5 qsaal
  atm pvc 2 0 16 ilmi
interface atm 1/0.3
  ip address 172.16.0.5 255.255.255.0
  lane client ethernet
```

## Default Configuration for a Single Ethernet Emulated LAN with a Backup LANE Configuration Server and LANE Server Example

This example configures four Cisco 7500 series routers for one emulated LAN with fault tolerance. Router 1 contains the configuration server, the server, the broadcast-and-unknown server, and a client. Router 2 contains the backup LANE configuration server and the backup LANE server for this emulated LAN and another client. Routers 3 and 4 contain clients only. This example accepts all default settings that are provided. For example, it does not explicitly set ATM addresses for the various LANE components colocated on the router. Membership in this LAN is not restricted.

**Router 1**

```
lane database example1
  name eng server-atm-address 39.000001415555121101020304.0800.200c.1001.01
  name eng server-atm-address 39.000001415555121101020304.0612.200c 2001.01
  default-name eng
interface atm 1/0
  atm pvc 1 0 5 qsaal
  atm pvc 2 0 16 ilmi
  lane config auto-config-atm-address
  lane config database example1
interface atm 1/0.1
  ip address 172.16.0.1 255.255.255.0
  lane server-bus ethernet eng
  lane client ethernet
```

**Router 2**

```
lane database example1_backup
  name eng server-atm-address 39.000001415555121101020304.0800.200c.1001.01
  name eng server-atm-address 39.000001415555121101020304.0612.200c 2001.01 (backup LES)
  default-name eng
interface atm 1/0
  atm pvc 1 0 5 qsaal
  atm pvc 2 0 16 ilmi
  lane config auto-config-atm-address
  lane config database example1_backup
interface atm 1/0.1
  ip address 172.16.0.3 255.255.255.0
  lane server-bus ethernet eng
  lane client ethernet
```

Router 3

```
interface atm 2/0
 atm pvc 1 0 5 qsaal
 atm pvc 2 0 16 ilmi
interface atm 2/0.1
 ip address 172.16.0.4 255.255.255.0
 lane client ethernet
```

Router 4

```
interface atm 1/0
 atm pvc 1 0 5 qsaal
 atm pvc 2 0 16 ilmi
interface atm 1/0.3
 ip address 172.16.0.5 255.255.255.0
 lane client ethernet
```

Multiple Token Ring ELANs with Unrestricted Membership Example

The following example configures four Cisco 7500 series routers for three emulated LANS for Engineering, Manufacturing, and Marketing, as illustrated in Figure 20. This example does not restrict membership in the emulated LANs.

Figure 20 Multiple Emulated LANs

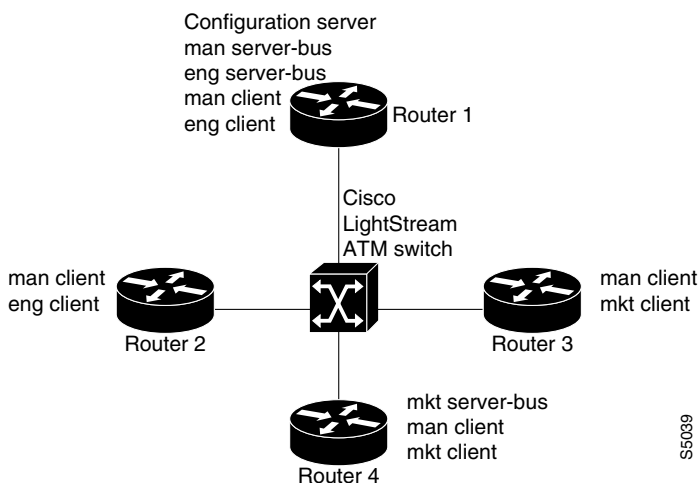

In this example, Router 1 has the following LANE components:

- The LANE configuration server (there is one configuration server for this group of emulated LANs)
- The LANE server and broadcast-and-unknown server for the emulated LAN for Manufacturing (*man*)
- The LANE server and broadcast-and-unknown server for the emulated LAN for Engineering (*eng*)
- A LANE client for the emulated LAN for Manufacturing (*man*)
- A LANE client for the emulated LAN for Engineering (*eng*)

Router 2 has the following LANE components:

- A LANE client for the emulated LAN for Manufacturing (*man*)
- A LANE client for the emulated LAN for Engineering (*eng*)

Router 3 has the following LANE components:

- A LANE client for the emulated LAN for Manufacturing (*man*)
- A LANE client for the emulated LAN for Marketing (*mkt*)

Router 4 has the following LANE components:

- The LANE server and broadcast-and-unknown server for the emulated LAN for Marketing (*mkt*)
- A LANE client for the emulated LAN for Manufacturing (*man*)
- A LANE client for the emulated LAN for Marketing (*mkt*)

For the purposes of this example, the four routers are assigned ATM address prefixes and end system identifiers (ESIs) as shown in Table 8 (the ESI part of the ATM address is derived from the first MAC address of the AIP shown in the example).

**Table 8 ATM Prefixes for TR-LANE Example**

Router	ATM Address Prefix	ESI Base
Router 1	39.000001415555121101020304	0800.200c.1000
Router 2	39.000001415555121101020304	0800.200c.2000
Router 3	39.000001415555121101020304	0800.200c.3000
Router 4	39.000001415555121101020304	0800.200c.4000

## Router 1

Router 1 has the configuration server and its database, the server and broadcast-and-unknown server for the Manufacturing emulated LAN, the server and broadcast-and-unknown server for the Engineering emulated LAN, a client for Manufacturing, and a client for Engineering. Router 1 is configured as shown in this example:

```
!The following lines name and configure the configuration server's database.
lane database example2
 name eng server-atm-address 39.000001415555121101020304.0800.200c.1001.02
 name eng local-seg-id 1000
 name man server-atm-address 39.000001415555121101020304.0800.200c.1001.01
 name man local-seg-id 2000
 name mkt server-atm-address 39.000001415555121101020304.0800.200c.4001.01
 name mkt local-seg-id 3000
 default-name man
!
! The following lines bring up the configuration server and associate
! it with a database name.
interface atm 1/0
 atm pvc 1 0 5 qsaal
 atm pvc 2 0 16 ilmi
 lane config auto-config-atm-address
 lane config database example2
!
! The following lines configure the "man" server, broadcast-and-unknown server,
! and the client on atm subinterface 1/0.1. The client is assigned to the default
! emulated lan.
interface atm 1/0.1
```

```
ip address 172.16.0.1 255.255.255.0
lane server-bus tokenring man
lane client tokenring man
!
! The following lines configure the "eng" server, broadcast-and-unknown server,
! and the client on atm subinterface 1/0.2. The client is assigned to the
! engineering emulated lan. Each emulated LAN is a different subnetwork, so the "eng"
! client has an IP address on a different subnetwork than the "man" client.
interface atm 1/0.2
ip address 172.16.1.1 255.255.255.0
lane server-bus tokenring eng
lane client tokenring eng
```

### Router 2

Router 2 is configured for a client of the Manufacturing emulated LAN and a client of the Engineering emulated LAN. Because the default emulated LAN name is *man*, the first client is linked to that emulated LAN name by default. Router 2 is configured as shown here:

```
interface atm 1/0
atm pvc 1 0 5 qsaal
atm pvc 2 0 16 ilmi
interface atm 1/0.1
ip address 172.16.0.2 255.255.255.0
lane client tokenring
interface atm 1/0.2
ip address 172.16.1.2 255.255.255.0
lane client tokenring eng
```

### Router 3

Router 3 is configured for a client of the Manufacturing emulated LAN and a client of the Marketing emulated LAN. Because the default emulated LAN name is *man*, the first client is linked to that emulated LAN name by default. Router 3 is configured as shown here:

```
interface atm 2/0
atm pvc 1 0 5 qsaal
atm pvc 2 0 16 ilmi
interface atm 2/0.1
ip address 172.16.0.3 255.255.255.0
lane client tokenring
interface atm 2/0.2
ip address 172.16.2.3 255.255.255.0
lane client tokenring mkt
```

### Router 4

Router 4 has the server and broadcast-and-unknown server for the Marketing emulated LAN, a client for Marketing, and a client for Manufacturing. Because the default emulated LAN name is *man*, the second client is linked to that emulated LAN name by default. Router 4 is configured as shown here:

```
interface atm 3/0
atm pvc 1 0 5 qsaal
atm pvc 2 0 16 ilmi
interface atm 3/0.1
ip address 172.16.2.4 255.255.255.0
lane server-bus tokenring mkt
lane client tokenring mkt
interface atm 3/0.2
ip address 172.16.0.4 255.255.255.0
lane client tokenring
```

## Multiple Token Ring ELANs with Restricted Membership Example

The following example, illustrated in Figure 21, configures a Cisco 7500 series router for three emulated LANS for Engineering, Manufacturing, and Marketing.

The same components are assigned to the four routers as in the previous example. The ATM address prefixes and MAC addresses are also the same as in the previous example.

However, this example restricts membership for the Engineering and Marketing emulated LANs. The LANE configuration server's database has explicit entries binding the ATM addresses of LANE clients to specified, named emulated LANs. In such cases, the client requests information from the configuration server about which emulated LAN it should join; the configuration server checks its database and replies to the client. Since the Manufacturing emulated LAN is unrestricted, any client not in the LANE configuration server's database is allowed to join it.

**Figure 21 Multiple Emulated LANs with Restricted Membership**

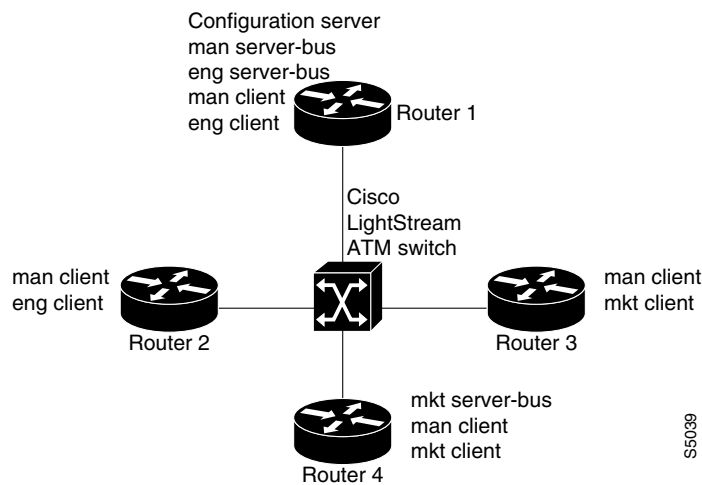

### Router 1

Router 1 has the configuration server and its database, the server and broadcast-and-unknown server for the Manufacturing emulated LAN, the server and broadcast-and-unknown server for the Engineering emulated LAN, a client for Manufacturing, and a client for Engineering. It also has explicit database entries binding the ATM addresses of LANE clients to specified, named emulated LANs. Router 1 is configured as shown here:

```
! The following lines name and configure the configuration server's database.
lane database example3
name eng server-atm-address 39.000001415555121101020304.0800.200c.1001.02 restricted
name eng local-seg-id 1000
name man server-atm-address 39.000001415555121101020304.0800.200c.1001.01
name man local-seg-id 2000
name mkt server-atm-address 39.000001415555121101020304.0800.200c.4001.01 restricted
name mkt local-seg-id 3000
!
! The following lines add database entries binding specified client ATM
! addresses to emulated LANs. In each case, the Selector byte corresponds
! to the subinterface number on the specified router.
! The next command binds the client on Router 1's subinterface 2 to the eng ELAN.
client-atm-address 39.0000014155551211.0800.200c.1000.02 name eng
! The next command binds the client on Router 2's subinterface 2 to the eng ELAN.
client-atm-address 39.0000014155551211.0800.200c.2000.02 name eng
```

```
! The next command binds the client on Router 3's subinterface 2 to the mkt ELAN.
client-atm-address 39.0000014155551211.0800.200c.3000.02 name mkt
! The next command binds the client on Router 4's subinterface 1 to the mkt ELAN.
client-atm-address 39.0000014155551211.0800.200c.4000.01 name mkt
default-name man
!
! The following lines bring up the configuration server and associate
! it with a database name.
interface atm 1/0
  atm pvc 1 0 5 qsaal
  atm pvc 2 0 16 ilmi
  lane config auto-config-atm-address
  lane config database example3
!
! The following lines configure the "man" server/broadcast-and-unknown server,
! and the client on atm subinterface 1/0.1. The client is assigned to the default
! emulated lan.
interface atm 1/0.1
  ip address 172.16.0.1 255.255.255.0
  lane server-bus tokenring man
  lane client tokenring
!
! The following lines configure the "eng" server/broadcast-and-unknown server
! and the client on atm subinterface 1/0.2. The configuration server assigns the
! client to the engineering emulated lan.
interface atm 1/0.2
  ip address 172.16.1.1 255.255.255.0
  lane server-bus tokenring eng
  lane client tokenring eng
```

### Router 2

Router 2 is configured for a client of the Manufacturing emulated LAN and a client of the Engineering emulated LAN. Because the default emulated LAN name is *man*, the first client is linked to that emulated LAN name by default. Router 2 is configured as shown in this example:

```
interface atm 1/0
  atm pvc 1 0 5 qsaal
  atm pvc 2 0 16 ilmi
! This client is not in the configuration server's database, so it will be
! linked to the "man" ELAN by default.
interface atm 1/0.1
  ip address 172.16.0.2 255.255.255.0
  lane client tokenring
! A client for the following interface is entered in the configuration
! server's database as linked to the "eng" ELAN.
interface atm 1/0.2
  ip address 172.16.1.2 255.255.255.0
  lane client tokenring eng
```

### Router 3

Router 3 is configured for a client of the Manufacturing emulated LAN and a client of the Marketing emulated LAN. Because the default emulated LAN name is *man*, the first client is linked to that emulated LAN name by default. The second client is listed in the database as linked to the *mkt* emulated LAN. Router 3 is configured as shown in this example:

```
interface atm 2/0
  atm pvc 1 0 5 qsaal
  atm pvc 2 0 16 ilmi
! The first client is not entered in the database, so it is linked to the
! "man" ELAN by default.
```

```

interface atm 2/0.1
 ip address 172.16.0.3 255.255.255.0
 lane client tokenring man
 ! The second client is explicitly entered in the configuration server's
 ! database as linked to the "mkt" ELAN.
interface atm 2/0.2
 ip address 172.16.2.3 255.255.255.0
 lane client tokenring mkt

```

#### Router 4

Router 4 has the server and broadcast-and-unknown server for the Marketing emulated LAN, a client for Marketing, and a client for Manufacturing. The first client is listed in the database as linked to the *mkt* emulated LANs. The second client is not listed in the database, but is linked to the *man* emulated LAN name by default. Router 4 is configured as shown here:

```

interface atm 3/0
 atm pvc 1 0 5 qsaal
 atm pvc 2 0 16 ilmi
 ! The first client is explicitly entered in the configuration server's
 ! database as linked to the "mkt" ELAN.
interface atm 3/0.1
 ip address 172.16.2.4 255.255.255.0
 lane server-bus tokenring mkt
 lane client tokenring mkt
 ! The following client is not entered in the database, so it is linked to the
 ! "man" ELAN by default.
interface atm 3/0.2
 ip address 172.16.0.4 255.255.255.0
 lane client tokenring

```

## TR-LANE with 2-Port Source-Route Bridging Example

The following example configures two Cisco 7500 series routers for one emulated Token-Ring LAN using source-route bridging, as illustrated in Figure 22. This example does not restrict membership in the emulated LANs.

**Figure 22 2-Port Source-Route Bridging TR-LANE**

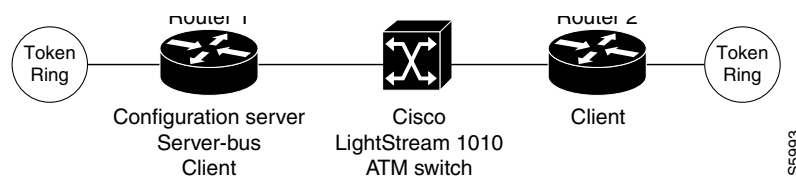

#### Router 1

Router 1 contains the configuration server, the server and broadcast-and-unknown server, and a client. Router 1 is configured as shown in this example:

```

hostname Router1
!
! The following lines configure the database cisco_eng.
lane database cisco_eng
name elan1 server-atm-address 39.020304050607080910111213.00000CA05B41.01
name elan1 local-seg-id 2048
default-name elan1

```

```
!  
interface Ethernet0/0  
 ip address 10.6.10.4 255.255.255.0  
!  
! The following lines configure a configuration server using the cisco_eng database on  
! the interface. No IP address is needed since we are using source-route bridging.  
interface ATM2/0  
 no ip address  
 atm pvc 1 0 5 qsaal  
 atm pvc 2 0 16 ilmi  
 lane config auto-config-atm-address  
 lane config database cisco_eng  
!  
! The following lines configure the server-bus and the client on the subinterface and  
! specify source-route bridging information.  
interface ATM2/0.1 multipoint  
 lane server-bus tokenring elan1  
 lane client tokenring elan1  
 source-bridge 2048 1 1  
 source-bridge spanning  
!  
! The following lines configure source-route bridging on the Token Ring interface.  
interface TokenRing3/0/0  
 no ip address  
 ring-speed 16  
 source-bridge 1 1 2048  
 source-bridge spanning  
!  
router igrp 65529  
 network 10.0.0.0
```

### Router 2

Router 2 contains only a client for the emulated LAN. Router 2 is configured as shown here:

```
hostname Router2  
!  
interface Ethernet0/0  
 ip address 10.6.10.5 255.255.255.0  
!  
! The following lines configure source-route bridging on the Token Ring interface.  
interface TokenRing1/0  
 no ip address  
 ring-speed 16  
 source-bridge 2 2 2048  
 source-bridge spanning  
!  
! The following lines set up the signaling and ILMI PVCs.  
interface ATM2/0  
 no ip address  
 atm pvc 1 0 5 qsaal  
 atm pvc 2 0 16 ilmi  
!  
! The following lines set up a client on the subinterface and configure  
! source-route bridging.  
interface ATM2/0.1 multipoint  
 ip address 1.1.1.2 255.0.0.0  
 lane client tokenring elan1  
 source-bridge 2048 2 2  
 source-bridge spanning  
!  
router igrp 65529  
 network 10.0.0.0
```

## TR-LANE with Multiport Source-Route Bridging Example

The following example configures two Cisco 7500 series routers for one emulated Token-Ring LAN using source-route bridging, as illustrated in Figure 23. Since each router connects to three rings (the two Token Rings and the emulated LAN “ring”), a virtual ring must be configured on the router. This example does not restrict membership in the emulated LANs.

**Figure 23 Multiport Source-Route Bridged Token Ring Emulated LAN**

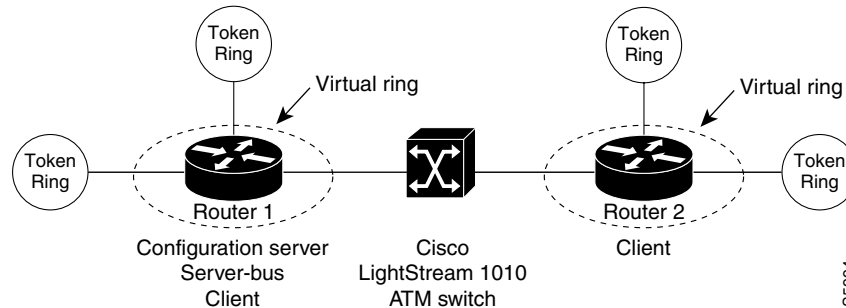

### Router 1

Router 1 contains the configuration server, the server and broadcast-and-unknown server, and a client. Router 1 is configured as shown in this example:

```
hostname Router1
!
! The following lines configure the database with the information about the
! elan1 emulated Token Ring LAN.
lane database cisco_eng
name elan1 server-atm-address 39.020304050607080910111213.00000CA05B41.01
name elan1 local-seg-id 2048
default-name elan1
!
! The following line configures virtual ring 256 on the router.
source-bridge ring-group 256
!
interface Ethernet0/0
 ip address 10.6.10.4 255.255.255.0
!
! The following lines configure the configuration server to use the cisco_eng database.
! The Signalling and ILMI PVCs are also configured.
interface ATM2/0
 no ip address
 atm pvc 1 0 5 qsaal
 atm pvc 2 0 16 ilmi
 lane config auto-config-atm-address
 lane config database cisco_eng
!
! The following lines configure the server and broadcast-and-unknown server and a client
! on the interface. The lines also specify source-route bridging information.
interface ATM2/0.1 multipoint
 lane server-bus tokenring elan1
 lane client tokenring elan1
 source-bridge 2048 5 256
 source-bridge spanning
!
```

```
! The following lines configure the Token Ring interfaces.
interface TokenRing3/0
  no ip address
  ring-speed 16
  source-bridge 1 1 256
  source-bridge spanning
interface TokenRing3/1
  no ip address
  ring-speed 16
  source-bridge 2 2 256
  source-bridge spanning
!
router igrp 65529
  network 10.0.0.0
```

### Router 2

Router 2 contains only a client for the emulated LAN. Router 2 is configured as shown here:

```
hostname Router2
!
! The following line configures virtual ring 512 on the router.
source-bridge ring-group 512
!
interface Ethernet0/0
  ip address 10.6.10.5 255.255.255.0
!
! The following lines configure the Token Ring interfaces.
interface TokenRing1/0
  no ip address
  ring-speed 16
  source-bridge 3 3 512
  source-bridge spanning
interface TokenRing1/1
  no ip address
  ring-speed 16
  source-bridge 4 4 512
  source-bridge spanning
!
! The following lines configure the signaling and ILMI PVCs.
interface ATM2/0
  no ip address
  atm pvc 1 0 5 qsaal
  atm pvc 2 0 16 ilmi
!
! The following lines configure the client. Source-route bridging is also configured.
interface ATM2/0.1 multipoint
  ip address 1.1.1.2 255.0.0.0
  lane client tokenring elan1
  source-bridge 2048 6 512
  source-bridge spanning
!
router igrp 65529
  network 10.0.0.0
```

## Routing between Token Ring and Ethernet Emulated LANs Example

This example, shown in Figure 24, configures routing between a Token Ring emulated LAN (*trelan*) and an Ethernet emulated LAN (*ethelan*) on the same ATM interface. Router 1 contains the LANE configuration server, a LANE server and broadcast-and-unknown server for each emulated LAN, and a client for each emulated LAN. Router 2 contains a client for *trelan* (Token Ring); Router 3 contains a client for *ethelan* (Ethernet).

**Figure 24 Routing between Token Ring and Ethernet Emulated LANs**

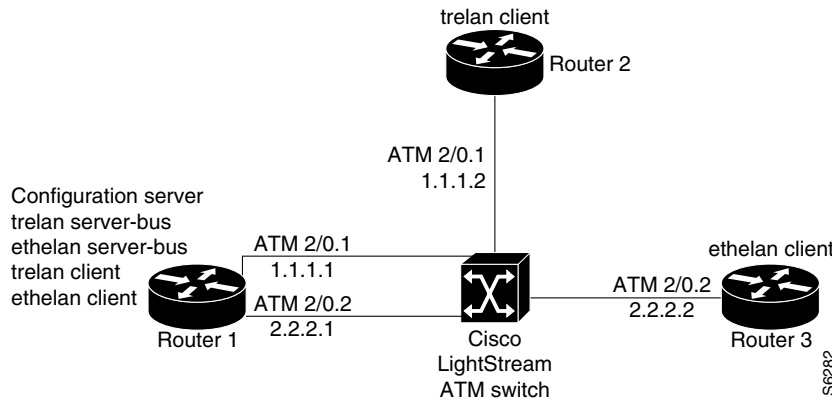

### Router 1

Router 1 contains the LANE configuration server, a LANE server and broadcast-and-unknown server for each emulated LAN, and a client for each emulated LAN. Router 1 is configured as shown in this example:

```
hostname router1
!
! The following lines name and configures the configuration server's database.
! The server addresses for trelan and ethelan and the ELAN ring number for
! trelan are entered into the database. The default ELAN is trelan.
lane database cisco_eng
name trelan server-atm-address 39.020304050607080910111213.00000CA05B41.01
name trelan local-seg-id 2048
name ethelan server-atm-address 39.020304050607080910111213.00000CA05B41.02
default-name trelan
!
! The following lines enable the configuration server and associate it
! with the cisco_eng database.
interface ATM2/0
no ip address
atm pvc 1 0 5 qsaal
atm pvc 2 0 16 ilmi
lane config auto-config-atm-address
lane config database cisco_eng
!
! The following lines configure the tokenring LES/BUS and LEC for trelan
! on subinterface atm2/0.1 and assign an IP address to the subinterface.
interface ATM2/0.1 multipoint
ip address 10.1.1.1 255.255.255.0
lane server-bus tokenring trelan
lane client tokenring trelan
!
```

```
! The following lines configure the Ethernet LES/BUS and LEC for ethelan
! on subinterface atm2/0.2 and assign an IP address to the subinterface.
interface ATM2/0.2 multipoint
 ip address 20.2.2.1 255.255.255.0
 lane server-bus ethernet ethelan
 lane client ethernet ethelan
!
! The following lines configure the IGRP routing protocol to enable routing
! between ELANS.
router igrp 1
 network 10.0.0.0
 network 20.0.0.0
```

### Router 2

Router 2 contains a client for *trelan* (Token Ring). Router 2 is configured as follows:

```
hostname router2
!
! The following lines set up the signaling and ILMI PVCs for the interface.
interface ATM2/0
 no ip address
 no keepalive
 atm pvc 1 0 5 qsaal
 atm pvc 2 0 16 ilmi
!
! The following lines configure a Token Ring LEC on atm2/0.1 and assign
! an IP address to the subinterface.
interface ATM2/0.1 multipoint
 ip address 10.1.1.2 255.255.255.0
 lane client tokenring trelan
!
! The following lines configure the IGRP routing protocol to enable routing
! between ELANS.
router igrp 1
 network 10.0.0.0
 network 20.0.0.0
```

### Router 3

Router 3 contains a client for *ethelan* (Ethernet). Router 3 is configured as follows:

```
hostname router3
!
! The following lines set up the signaling and ILMI PVCs for the interface.
interface ATM2/0
 no ip address
 no ip mroute-cache
 atm pvc 1 0 5 qsaal
 atm pvc 2 0 16 ilmi
!
! The following lines configure an Ethernet LEC on atm2/0.1 and assign
! an IP address to the subinterface.
interface ATM2/0.1 multipoint
 ip address 20.2.2.2 255.255.255.0
 lane client ethernet ethelan
!
! The following lines configure the IGRP routing protocol to enable routing
! between ELANS.
router igrp 1
 network 10.0.0.0
 network 20.0.0.0
```