

Configuring IBM Network Media Translation

This chapter describes how to configure the Cisco IOS software for IBM network media translation with SDLLC or Qualified Logical Link Control (QLLC). For a complete description of the commands in this chapter, refer to the “IBM Network Media Translation Commands” chapter in the *Bridging and IBM Networking Command Reference*. To locate documentation of other commands that appear in this chapter, use the command reference master index or search online.

SDLLC Configuration Task List

To configure SDLLC, perform the tasks in the following sections:

- Configure SDLLC with Direct Connection
- Configure SDLLC with Remote Source-Route Bridging (RSRB)
- Configure SDLLC with RSRB and Local Acknowledgment
- Configure SDLLC with Ethernet and Translational Bridging
- Customize SDLLC Media Translation
- Monitor SDLLC Media Translation

Note Because data-link switching plus (DLSw+) contains its own media conversion, SDLLC is not required when using DLSw+.

See the end of this chapter for “SDLLC Configuration Examples.”

Configure SDLLC with Direct Connection

In the SDLLC configuration with direct connection, a 37x5 front-end processor (FEP) on a Token Ring and a 3x74 cluster controller connected to a serial line are each connected to an interface on the same router configured with SDLLC. In this configuration, the Logical Link Control, type 2 (LLC2) session extends from the 37x5 FEP across the Token Ring to the router. The SDLLC session extends from the router across the serial line to the 3x74 cluster controller. The Systems Network Architecture (SNA) session extends across the Token Ring and the serial line to provide an end-to-end connection. The router is configured with source-route bridging (SRB).

To configure SDLLC with direct connection, you must perform the tasks in the following sections:

- Enable SDLLC Media Translation
- Associate a Service Access Point (SAP) Value
- Specify the Exchange Identification (XID) Value
- Initiate Connection to Token Ring Host

For an example of how to configure SDLLC with direct connection, see the “SDLLC with Direct Connection Example” later in this chapter.

Enable SDLLC Media Translation

The interfaces you will configure for SDLLC media translation are the serial interfaces that connect to the serial lines linking the remote Synchronous Data Link Control (SDLC) devices. To configure them, perform the following task in interface configuration mode:

Task	Command
Enable SDLLC media translation on a serial interface.	sdllc traddr <i>xxxx.xxxx.xx00 lr bn tr</i>

Associate a Service Access Point (SAP) Value

You can associate a SAP value by performing the following task in interface configuration mode:

Task	Command
Associate a SAP value.	sdllc sap <i>sdllc-address ssap dsap</i>

Specify the Exchange Identification (XID) Value

The XID value you define in the Cisco IOS software must match that of the IDBLK and IDNUM system generation parameters defined in VTAM of the Token Ring host to which the SDLC device will be communicating. To define XID, perform the following task in interface configuration mode:

Task	Command
Specify the XID value appropriate for the SDLC station to match VTAM values.	sdllc xid <i>address xxxxxxxx</i>

Initiate Connection to Token Ring Host

The Token Ring host is always kept in a state ready to accept a connection from the remote serial device. The remote serial device is responsible for initiating connections. The advantage of this scheme is that the serial device can communicate with the Token Ring host whenever it chooses without requiring personnel to be on the host site.

The Cisco IOS software actually initiates the connection on behalf of the serial device. To initiate connections, both the media access control (MAC) address of the Token Ring host and the SDLC line address are required. You must configure the Cisco IOS software to define the Token Ring host

as the partner of the serial device. To do so, perform the following task in interface configuration mode:

Task	Command
Enable connections for SDLLC.	sdllc partner <i>mac-address</i> <i>sdlc-address</i>

Configure SDLLC with Remote Source-Route Bridging (RSRB)

A router need not directly connect the two IBM end nodes: a 37x5 FEP on a Token Ring and a 3x74 cluster controller connected to a serial line can be connected to different routers. However, the router to which the 3x74 is connected must be configured with SDLLC. They communicate via RSRB using direct encapsulation, RSRB over an FST connection, or RSRB over a TCP connection. RSRB transports packets between Router A and Router B, while Router B performs all conversion between the LLC2 and SDLC protocols by means of the SDLLC software.

To configure the router for SDLLC with RSRB, you must perform all the tasks in the “Configure SDLLC with Direct Connection” section earlier in this chapter. In addition, you must perform one of the sets of tasks in the following sections:

- Configure RSRB Using Direct Encapsulation
- Configure RSRB over FST Connection
- Configure RSRB over TCP Connection

For more information about configuring RSRB, see the chapter “Configuring Source-Route Bridging” in this publication and “Source-Route Bridging Commands” in the *Bridging and IBM Networking Command Reference*.

Note When you configure RSRB, you must include a **source-bridge remote peer** command on the router connected to the serial line and another **source-bridge remote peer** command on the one connected to the Token Ring. If you have more than one serial line connected to the same router, then you will have a **source-bridge remote peer** command for each interface in its configuration that will be using SDLLC with RSRB.

For an example of how to configure SDLLC with RSRB, see the section “SDLLC with RSRB (Multiple 3x74s) Example” later in this chapter.

Configure RSRB Using Direct Encapsulation

To configure SDLLC with RSRB using direct encapsulation, perform the following tasks in global configuration mode:

Task	Command
Define a ring group.	source-bridge ring-group <i>ring-group</i> [<i>virtual-mac-address</i>]
Define a remote peer.	source-bridge remote-peer <i>ring-group</i> interface <i>interface-name</i> [<i>mac-address</i>]

Configure RSRB over FST Connection

To configure SDLLC with RSRB over an FST connection, perform the following tasks in global configuration mode:

Task	Command
Define a ring group.	source-bridge ring-group <i>ring-group</i> [<i>virtual-mac-address</i>]
For FST connection only, set up an FST peer name.	source-bridge fst-peername <i>local-interface-address</i>
Define a remote peer.	source-bridge remote-peer <i>ring-group</i> fst <i>ip-address</i>

Configure RSRB over TCP Connection

To configure SDLLC with RSRB over a TCP connection, perform the following tasks in global configuration mode:

Task	Command
Define a ring group.	source-bridge ring-group <i>ring-group</i> [<i>virtual-mac-address</i>]
Define a remote peer.	source-bridge remote-peer <i>ring-group</i> tcp <i>ip-address</i>

Configure SDLLC with RSRB and Local Acknowledgment

RSRB can be configured for only local acknowledgment with RSRB using IP encapsulation over a TCP connection. Configuring SDLLC local acknowledgment can reduce time-outs and keepalive traffic on the connection.

If LLC2 local acknowledgment is configured, it must be configured on the serial interface of the router on the 3x74 cluster controller side of the connection and on the Token Ring interface of the router on the 37x5 FEP side of the connection. Whether or not local acknowledgment is configured, the SNA session extends end-to-end and the SDLC session extends from the router configured with the serial interface to the 3x74 cluster controller. However, the LLC2 session extends from the 37x5 FEP to the router with the Token Ring interface configured. The LLC2 session is locally terminated at that router. A TCP session is then established across the WAN to a router on the 3x74 side of the connection.

To configure the Cisco IOS software for SDLLC with RSRB and local acknowledgment, you must perform all the tasks in the “Configure SDLLC with Direct Connection” section earlier in this chapter. In addition, you must perform the following tasks in global configuration mode:

Task	Command
Define a ring group.	source-bridge ring-group <i>ring-group</i> [<i>virtual-mac-address</i>]
Define a remote peer with the local acknowledgment feature.	source-bridge remote-peer <i>ring-group</i> tcp <i>ip-address</i> local-ack
Enable local acknowledgment for connections involving SDLLC media translation.	source-bridge sdllc-local-ack

Local acknowledgment is not supported when the LLC2 device is attached to an Ethernet rather than to a Token Ring.

For an example of how to configure SDLLC with RSRB and local acknowledgment, see the section “SDLLC with RSRB and Local Acknowledgment Example” later in this chapter.

For more information about configuring RSRB and local acknowledgment, see the chapter “Configuring Source-Route Bridging” in this manual and “Source-Route Bridging Commands” in the *Bridging and IBM Networking Command Reference*.

Configure SDLLC with Ethernet and Translational Bridging

SDLLC support over Ethernet combines translational bridging with Ethernet support of 37x5 FEP connections. Figure 108 shows SDLLC with Ethernet and translational bridging. The 3x75 FEP is attached to Router A through Ethernet. The same router is configured for translational bridging, which translates Ethernet packets into Token Ring packets and passes them across the WAN to Router B connected to the 3x74 cluster controller via a serial line. The LLC2 session terminates at Router B connected to the 3x74 cluster controller. In addition, Router B maintains an SDLC session from itself to the cluster controller.

Figure 108 SDLLC with Ethernet and Translational Bridging

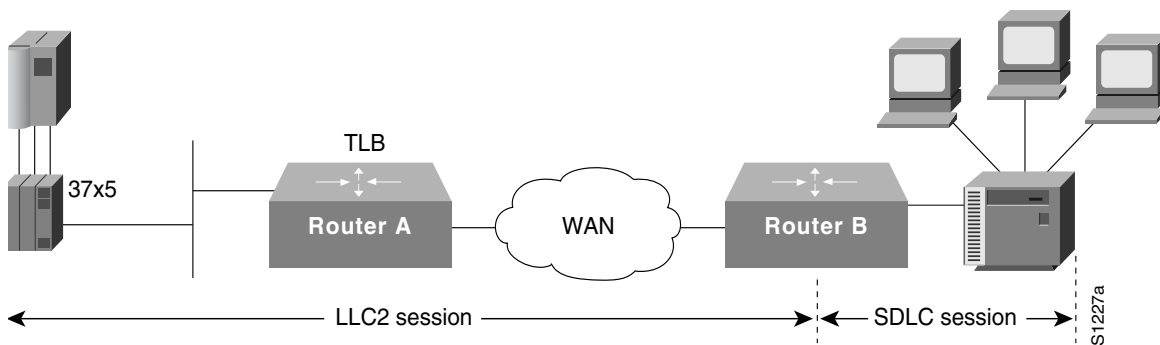

Customize SDLLC Media Translation

To increase performance on connections involving SDLLC media translation, perform the tasks in the following sections:

- Set the Largest LLC2 I-Frame Size
- Set the Largest SDLC I-Frame Size
- Increase the SDLC Line Speed

Refer to “Other Customizing Considerations” at the end of this section for additional information.

Set the Largest LLC2 I-Frame Size

Generally, the router and the LLC2 device with which it communicates should support the same maximum SDLC I-frame size. The larger this value, the better the line is used, thus increasing performance.

Faster screen updates to 3278-style terminals often result by configuring the Token Ring FEP to send as large an I-frame as possible and then allowing the Cisco IOS software to segment the frame into multiple SDLC I-frames.

After the Token Ring FEP has been configured to send the largest possible I-frame, it is best to configure the software to support the same maximum I-frame size. The default is 516 bytes. The maximum value the software can support is 8144 bytes.

To set the largest LLC2 I-frame size, perform the following task in interface configuration mode:

Task	Command
Specify the largest I-frame size that can be sent or received by the designated LLC2 primary station.	sdllc ring-largest-frame <i>value</i>

Set the Largest SDLC I-Frame Size

Generally, the router and the SDLC device with which it communicates should support the same maximum SDLC I-frame size. The larger this value, the better the line is utilized, thus increasing performance.

After the SDLC device has been configured to send the largest possible I-frame, you must configure the Cisco IOS software to support the same maximum I-frame size. The default is 265 bytes. The maximum value the software can support must be less than the value of the LLC2 largest frame value defined when setting the largest LLC2 I-frame size.

To set the largest SDLC I-frame size, perform the following task in interface configuration mode:

Task	Command
Set the largest I-frame size that can be sent or received by the designated SDLC station.	sdllc sdlc-largest-frame <i>address value</i>

Increase the SDLC Line Speed

You can increase the data transfer rate by increasing the SDLC line speed on the serial interface. If possible, increase the link speed of the 3x74 to 19.2 kbps on older units, or to 64 kbps on new units.

To increase the SDLC line speed, perform the following tasks in interface configuration mode:

Task	Command
Adjust the clock rate on the serial interface of the SCI and MCI cards to an acceptable bit rate.	clock rate <i>bps</i>

Other Customizing Considerations

In addition to adjusting the SDLLC parameters described in this section, you can improve performance on the connection by adjusting the LLC2 and SDLC parameters described in the chapter “Configuring LLC2 and SDLC Parameters.”

For IBM host configuration consider changing the default MAXOUT (window size) value. Widely used installation guides for IBM equipment show a MAXOUT value of 1 in the VTAM-switched major node for the IBM 3174 PU. Changing this value to 7 improves the performance, because VTAM can send seven frames before requiring an acknowledgment.

Monitor SDLLC Media Translation

To monitor connections using SDLLC media translation, perform the following monitoring tasks in privileged EXEC mode:

Task	Command
Display information about SDLC and LLC2 connections involving interfaces on which SDLLC media translation has been enabled.	show interfaces
Display the current state of any connections using local acknowledgment for LLC2 and SDLLC connections.	show sdllc local-ack
Display information about LLC2 connections involving interfaces on which SDLLC media translation has been enabled.	show llc2

In **show llc2** output, look for the LLC2 connections that correspond to the MAC addresses you assigned to the SDLLC interfaces using the **sdllc traddr** command. For information about these commands, see the chapter “LLC2 and SDLC Commands” and “IBM Network Media Translation Commands” in the *Bridging and IBM Networking Command Reference*.

QLLC Conversion Configuration Task List

Perform the tasks in the following sections to configure QLLC conversion. The first task is required; all others are optional and depend on your specific needs.

- Enable QLLC Conversion on a Serial Interface
- Customize QLLC Conversion
- Monitor QLLC Conversion

See the end of this chapter for QLLC configuration examples.

Enable QLLC Conversion on a Serial Interface

The interfaces you configure for QLLC conversion are the serial interfaces that connect to the X.25 network linking the remote devices with which you plan to communicate.

To enable QLLC conversion, you must perform the first of the following tasks. Perform the remaining tasks as appropriate.

- Enable QLLC Conversion on the Appropriate Serial Interfaces
- Define the XID Value Associated with an X.25 Device
- Enable to Open a Connection to the Local Token Ring Device

Enable QLLC Conversion on the Appropriate Serial Interfaces

You can enable QLLC conversion on a serial interface to support either a switched virtual circuit (SVC) or a permanent virtual circuit (PVC). The tasks you perform differ somewhat depending on the type of virtual circuit you plan to support on the interface. In either case, first verify that RSRB is enabled by performing the following task in privileged EXEC mode:

Task	Command
Ensure that RSRB is enabled on the interfaces.	show configuration

In the sections for the appropriate serial interfaces of the **show configuration** display, look for one or more **source-bridge remote-peer** entries and a **source-bridge rn** entry. For more information about configuring a serial interface for RSRB, see the chapter “Configuring LLC2 and SDLC Parameters” in this manual.

To enable QLLC conversion to support an SVC, perform the following tasks in interface configuration mode:

Task	Command
Step 1 Map a virtual Token Ring MAC address for the interface to its X.121 address.	x25 map qllc <i>virtual-mac-addr x121-addr</i> [<i>x25-map-options</i>]
Step 2 Enable the use of QLLC conversion on the interface.	qllc srb <i>virtual-mac-addr srn trn</i>

To enable QLLC conversion to support a PVC, perform the following tasks in interface configuration mode:

Task	Command
Step 1 Set up a PVC for QLLC conversion.	x25 pvc circuit qllc <i>x121-address</i> [<i>x25-map-options</i>]
Step 2 Enable the use of QLLC conversion on the interface.	qllc srb <i>virtual-mac-addr srn trn</i>

To configure QLLC to accept a call from any remote X.25 device, perform the following task in interface configuration mode:

Task	Command
Configure QLLC to accept a call from any remote X.25 device.	qllc accept-all-calls

In a Token Ring or RSRB environment the LAN-attached devices initiate a connection by sending a null XID packet upstream. If the Cisco IOS software forwards this null XID to an X.25-attached FEP, the FEP responds as if it were connecting to an PU2.1 device, and breaks the connection when the PU 2.0 next sends an XID Format 0 Type 2. To resolve this situation and to enable the connection, perform the following task in interface configuration mode:

Task	Command
Enable connection between a PU 2.0 on the LAN side and a FEP running NPSI on the X.25 side.	qllc npsi-poll <i>virtual-mac-addr</i>

The **qlc npsi-poll** command intercepts any null XID packet that the router receives on the LAN interface, and returns a null XID response to the downstream device. It continues to allow XID Format 3 and XID Format 0 packets through the X.25 device.

Define the XID Value Associated with an X.25 Device

The exchange identification (XID) serves as a password to ensure that only those devices that should communicate with the Token Ring host have that privilege. If the XID is defined in NCP on the host, you must enable the Cisco IOS software to reply (on behalf of the X.25 device) to the Token Ring host's requests for an XID reply. Although the XID value is used to reply to XID requests received on the LLC2 side of the connection, you apply this command on the serial interface defined for X.25. This XID value must match that of IDBLK and IDNUM defined in the NCP.

Note For most QLLC installations, you do not need to define the XID value. You only need to do so if the remote X.25 device is not configured to send its own XID. This is only possible for a device that is attached through a PVC, although most devices that are connected through X.25 send their own XIDs.

To define the XID value associated with an X.25 device, perform the following task in interface configuration mode:

Task	Command
Specify the XID value appropriate for the X.25 device associated with the Token Ring interface.	qlc xid <i>virtual-mac-addr xid</i>

Enable to Open a Connection to the Local Token Ring Device

If you plan to use SVCs rather than PVCs, you must enable the Cisco IOS software to open a connection to the local Token Ring device on behalf of the remote X.25 device when an incoming call is received. When QLLC conversion is used over an SVC, the remote X.25 device typically initiates the X.25/QLLC session, and the software in turn initiates the LLC2 session.

To enable the software to open a connection to the local Token Ring device, perform the following task in interface configuration mode:

Task	Command
Enable the software to open a connection to the local Token Ring device.	qlc partner <i>virtual-mac-addr mac-addr</i>

Customize QLLC Conversion

To customize your configuration of QLLC conversion, you can perform one or more of the following tasks:

- Enable QLLC local acknowledgment for remote source-route-bridged connections.
- Specify a SAP value other than the IBM default SAP value.
- Specify the largest packet that can be sent or received on the X.25 interface.

These tasks are described in the following sections.

Enable QLLC Local Acknowledgment for Remote Source-Route-Bridged Connections

Enable local acknowledgment when the round-trip time through the TCP/IP network is as large or larger than the LLC2 timeout period.

To enable QLLC local acknowledgment for RSRB connections, perform the following global configuration task on the router connected to the X.25 interface and configure the remote peers for local acknowledgment:

Task	Command
Enable QLLC local acknowledgment for remote source-route-bridged connections.	source-bridge qlc-local-ack

If, for example, Router B with X.25 interface has the IP address *ip1*, and the remote peer (Router A) has the address *ip2*, and they use a virtual ring group *vrg*, then both routers use the following configuration commands:

```
source-bridge ring-group vrg
source-bridge remote-peer vrg tcp ip1 local-ack
source-bridge remote-peer vrg tcp ip2
```

The configuration for Router B is as follows:

```
source-bridge ring-group vrg
source-bridge remote-peer vrg tcp ip1
source-bridge remote-peer vrg tcp ip2 local-ack
```

This will not affect Router A.

Specify SAP Values Other Than the Default IBM SAP Values

To use SAP values other than the default IBM SAP values, perform the following task in interface configuration mode:

Task	Command
Specify a SAP value other than the default IBM SAP value.	qlc sap <i>virtual-mac-addr ssap dsap</i>

Specify the Largest Packet That Can Be Sent or Received on the X.25 Interface

There are two ways for a packet to become segmented:

- The X.25 software performs the segmentation and the other X.25 station re-assembles the packet.
- The QLLC conversion performs SNA header segmentation. In this case, QLLC does not re-assemble, but passes smaller SNA segments to the IBM end station.

If the QLLC software does not perform SNA segmentation, then the X.25 software must be capable of performing X.25 segmentation of the largest packet that it can receive from the LLC2 side. This packet can be several thousand bytes long, whereas the typical size for X.25 packets is 1024 bytes or less. (The default is 128, but that can be overridden with larger values.) The X.25 software, especially in the X.25 attached IBM end station, might not be able to reassemble a very large packet. In this situation, specifying the largest QLLC packet can be useful.

By default, the maximum SNA data unit size established for the virtual circuit is the maximum packet size that can be sent or received on the X.25 interface. If packets received on the LLC2 interface are larger than the largest value allowed on the X.25 connection, they can be segmented by the X.25 software before being sent on the X.25 interface. Moreover, there is no reassembly on

receiving packets on the X.25 interface before sending them on the LLC2 interface. Thus, you might need to reconfigure the maximum packet size for the X.25 interface to match that for the LLC2 interface.

When the remote X.25 device has a limit on the maximum total length of recombined X.25 segments it will support, you must ensure the length is not exceeded. For example, a device whose maximum SNA packet size is limited to 265 bytes might not be able to handle a series of X.25 packets that it has to recombine to make a 4, 8, or 17 KB SNA packet, such as one often encounters in an LLC2 environment.

You cannot configure the X.25 interface with a larger packet size than the LLC2 interface.

To specify the largest packet that can be sent or received on the X.25 interface, perform the following task in interface configuration mode:

Task	Command
Specify the largest packet that can be sent or received on the X.25 interface.	qllc largest-packet <i>virtual-mac-address max-size</i>

Monitor QLLC Conversion

To monitor connections using QLLC conversion, perform the following tasks in privileged EXEC mode:

Task	Command
Display information about X.25 and LLC2 connections involving interfaces on which QLLC conversion has been enabled.	show interfaces serial <i>number</i>
Display the current state of any connections using QLLC local acknowledgment.	show qllc
Display information about LLC2 connections involving interfaces on which QLLC conversion has been enabled.	show llc2

SDLLC Configuration Examples

The following sections provide SDLLC configuration examples:

- SDLLC with Direct Connection Example
- SDLLC with Single Router Using RSRB Example
- SDLLC with RSRB (Single 3x74) Example
- SDLLC with RSRB (Multiple 3x74s) Example
- SDLLC with RSRB and Local Acknowledgment Example

Refer to the “NCP and VTAM Sysgen Parameters” section for sample NCP definitions that the 37x5 FEP in these topologies could use and VTAM definitions that the IBM host in these topologies could use to reflect the routers in the communication path.

SDLLC with Direct Connection Example

Figure 109 shows a router configuration when the router directly connects the Token Ring and the serial line. The Cisco IOS software is configured with SRB.

Figure 109 SDLLC Communication between a 37x5 and a 3x74 Connected to the Same Router (Direct Connection)

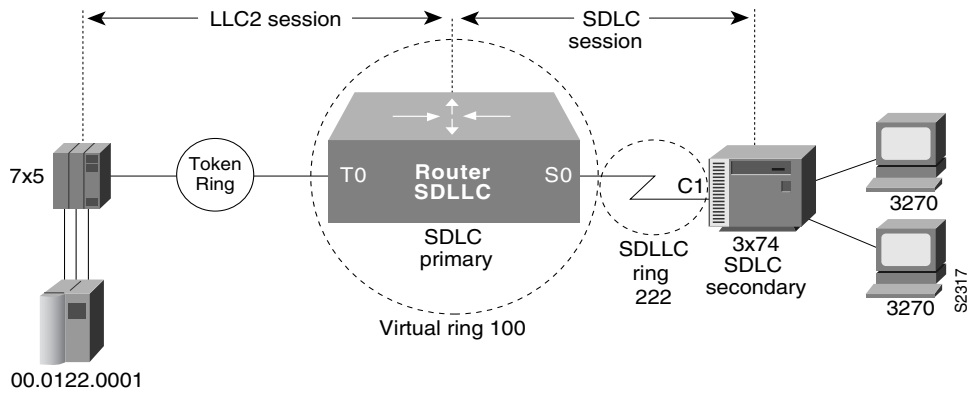

A configuration file that enables direct connection follows:

```

source-bridge ring-group 100
!
interface tokenring 0
 source-bridge 111 1 100
!
interface serial 0
 encapsulation sdhc-primary
 sdhc address c1
 sdllc traddr 0110.2222.3300 222 2 100
 sdllc partner 4000.0122.0001 c1
 sdllc xid c1 1720001
    
```

SDLLC with Single Router Using RSRB Example

Figure 110 shows a software configuration in which the router directly connects the Token Ring and the serial line, but uses RSRB to create a virtual ring 100. This configuration has the following characteristics:

- The FEP (37x5) sees C1 3x74 at MAC address 0110.2222.3300
- The RIF from the FEP to the devices would appear as:
ring 111—bridge 1—ring 100—bridge 1—ring 8

Figure 110 SDLLC with Single Router Using RSRB

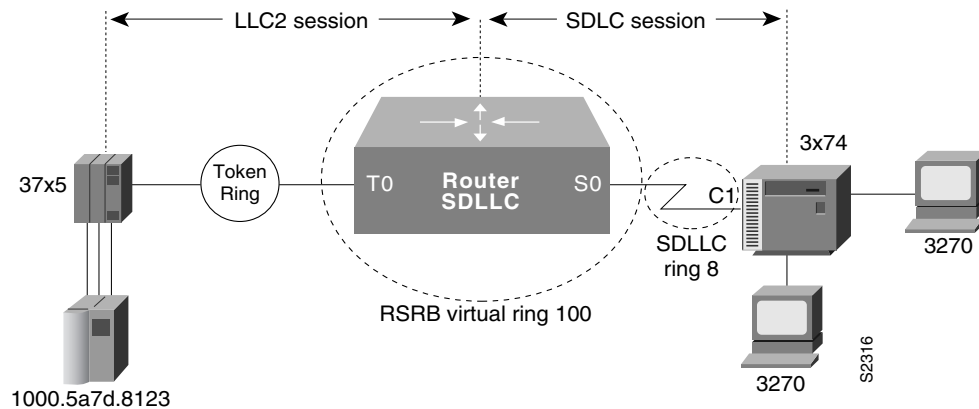

The following sample configuration file is for SDLLC with a single router using RSRB:

```
source-bridge ring-group 100
source-bridge remote-peer 100 tcp 131.108.1.1
source-bridge remote-peer 100 tcp 131.108.2.2

interface tokenring 0
 ip address 131.108.2.2 255.255.255.0
 source-bridge 111 1 100

interface serial 0
 encapsulation sdhc-primary
 sdhc address c1
 sdllc traddr 0110.2222.3300 8 1 100
 sdllc partner 1000.5a7d.8123 c1
 sdllc xid c1 17200c1
```

SDLLC with RSRB (Single 3x74) Example

In Figure 111, SDLLC with RSRB connects a FEP (37x5) and a single 3x74 cluster controller. The host wants to communicate with a single 3174 that its FEP sees on a Token Ring. However, the 3x74 seen by the FEP is in fact SDLC device C1 connected by means of a serial link through a remote router.

Figure 111 SDLLC with RSRB with a Single 3x74

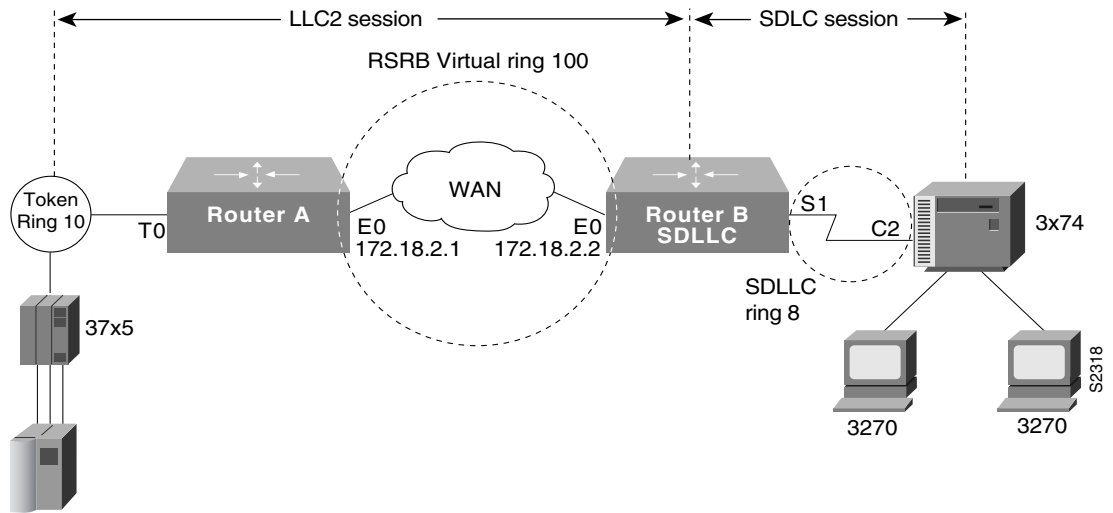

The configuration files for the network shown in Figure 111 follow.

Configuration for Router A

```

source-bridge ring-group 100
source-bridge remote-peer 100 tcp 131.108.1.1
source-bridge remote-peer 100 tcp 131.108.2.2
!
interface tokenring 0
 ip address 131.108.1.1 255.255.255.0
 source-bridge 10 1 100
!
interface ethernet 0
 ip address 131.108.2.1 255.255.255.0
    
```

Configuration for Router B

```

source-bridge ring-group 100
source-bridge remote-peer 100 tcp 131.108.1.1
source-bridge remote-peer 100 tcp 131.108.2.2
!
interface tokenring 0
 ip address 131.108.2.2 255.255.255.0
 source-bridge 1 1 100
!
interface serial 0
 encapsulation sdllc-primary
 sdllc address c1
 sdllc traddr 0110.2222.3300 8 1 100
 sdllc partner 1000.5a7d.8123 c1
 sdllc xid c1 17200c1
    
```

SDLLC with RSRB (Multiple 3x74s) Example

In the setup shown in Figure 112, Router A needs no SDLLC configuration, Router B has the SDLLC configuration and supports multipoint on the SDLC link with a modem-sharing device, and Router C is also configured with SDLLC. For information about the NCP and VTAM system generation (sysgen) parameters that are used in this configuration, see the “NCP and VTAM Sysgen Parameters” section later in this chapter.

Figure 112 SDLLC with RSRB with Multiple 3x74s

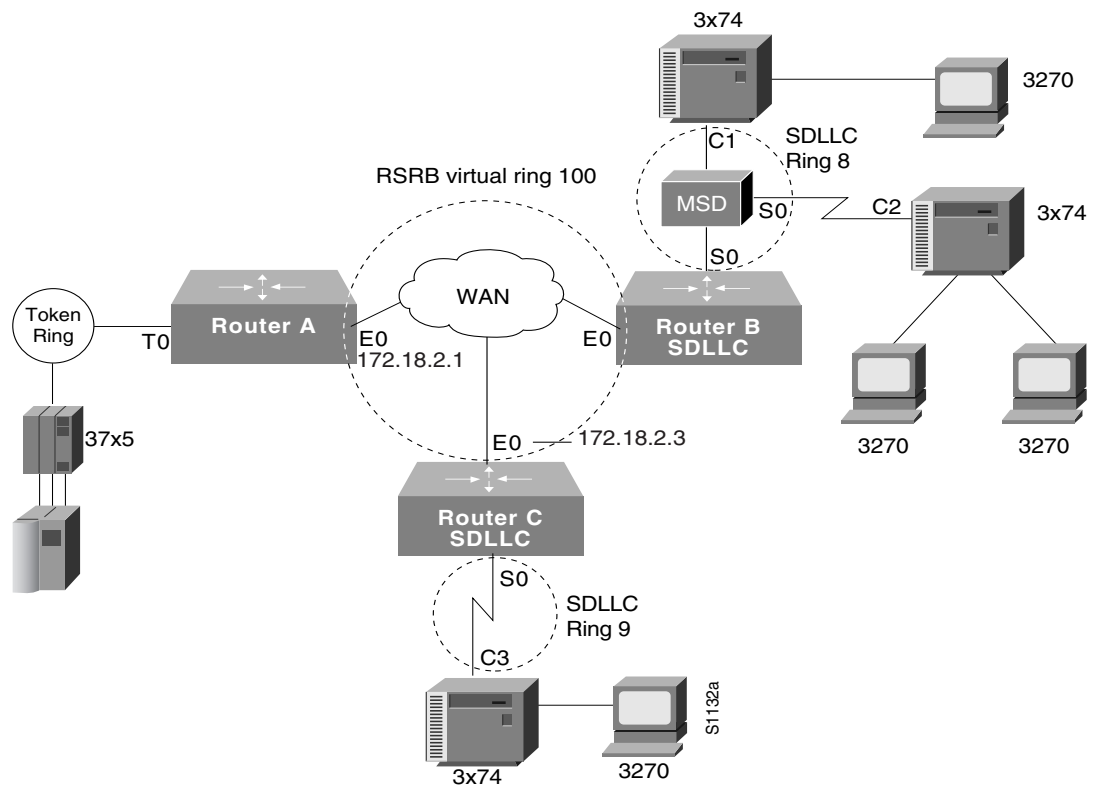

The following configuration files describe the network shown in Figure 112. The note references to the right of the configuration files refer to the “Notes” section at the end of this chapter.

Configuration for Router A

```

source-bridge ring-group 100
source-bridge remote-peer 100 tcp 131.108.2.1
source-bridge remote-peer 100 tcp 131.108.2.2
source-bridge remote-peer 100 tcp 131.108.2.3
!
interface tokenring 0
 ip address 131.108.1.1 255.255.255.0
 source-bridge 10 1 100
!
interface ethernet 0
 ip address 131.108.2.1 255.255.255.0

```

Configuration for Router B

```
source-bridge ring-group 100
source-bridge remote-peer 100 tcp 11.108.2.1
source-bridge remote-peer 100 tcp 11.108.2.2
source-bridge remote-peer 100 tcp 11.108.2.3
!
interface ethernet 0
 ip address 131.108.2.2 255.255.255.0
!
interface serial 0
 encapsulation sdlc-primary
 sdlc address c1
 sdlc address c2
 sdllc traddr 0110.2222.3300 7 1 100
 sdllc partner 1000.5a7d.8123 c1
 sdllc partner 1000.5a7d.8123 c2
 sdllc xid c1 17200c1
 sdllc xid c2 17200c2
```

Configuration for Router C

```
source-bridge ring-group 100
source-bridge remote-peer 100 tcp 131.108.2.1
source-bridge remote-peer 100 tcp 131.108.2.2
source-bridge remote-peer 100 tcp 131.108.2.3
!
interface ethernet 0
 ip address 131.108.2.3 255.255.255.0
!
interface serial 0
 encapsulation sdlc-primary
 sdlc address c3
 sdllc traddr 0110.2222.3300 9 1 100
 sdllc partner 1000.5a7d.8123 c3 MUST MATCH TIC LOCADD, NOTE 2
 sdllc xid c3 17200c3 MUST MATCH VTAM IDBLK/IDNUM, NOTE 4
```

SDLLC with RSRB and Local Acknowledgment Example

The configuration shown in Figure 113 enables local acknowledgment for Router B, which means that the LLC session terminates at Router A. However, the LLC2 session between Router A and Router C is not locally acknowledged and terminates at Router C.

For information about the NCP and VTAM system generation (sysgen) parameters that are used in this configuration, see the “NCP and VTAM Sysgen Parameters” section later in this chapter.

Figure 113 SDLLC with RSRB and Local Acknowledgment

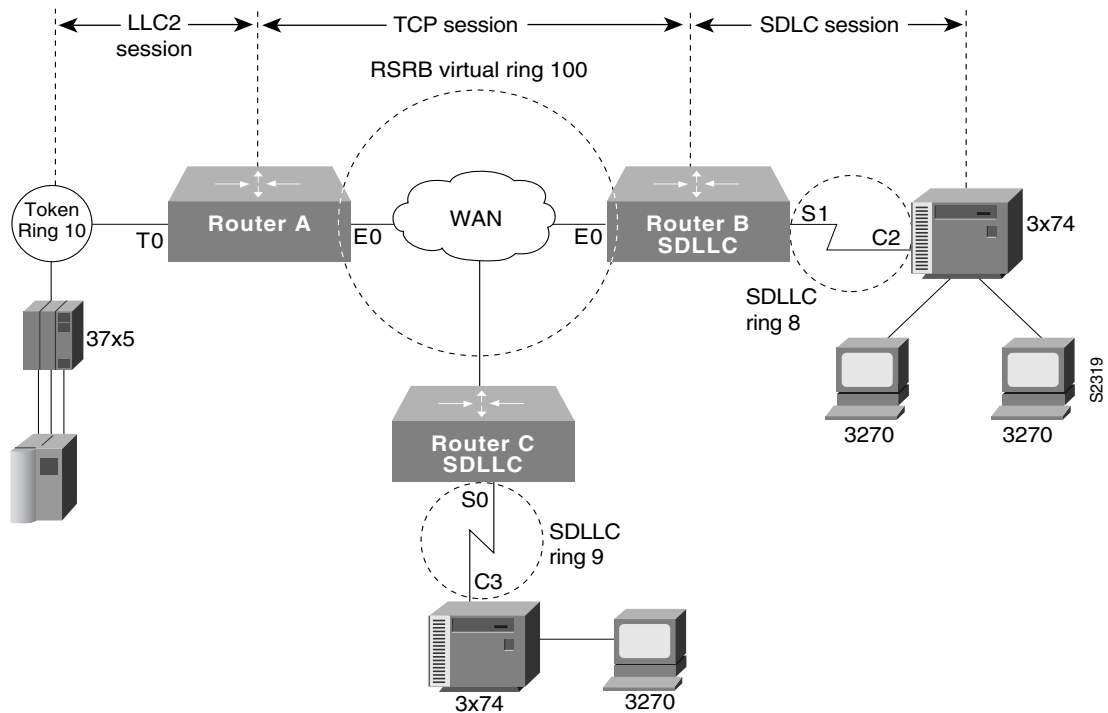

The following sample configuration files describe the network shown in Figure 113. (The notes in the sample configuration files refer to the “Notes” section at the end of this chapter.)

Configuration for Router A

```
source-bridge ring-group 100
source-bridge remote-peer 100 tcp 131.108.2.1
source-bridge remote-peer 100 tcp 131.108.2.2 local-ack
source-bridge remote-peer 100 tcp 131.108.2.3
!
interface tokenring 0
 ip address 131.108.1.1 255.255.255.0
 source-bridge 1 1 100
!
interface ethernet 0
 ip address 131.108.2.1 255.255.255.0
```

Configuration for Router B

```
source-bridge ring-group 100
source-bridge remote-peer 100 tcp 131.108.2.1 local-ack
source-bridge remote-peer 100 tcp 131.108.2.2
source-bridge remote-peer 100 tcp 131.108.2.3

source-bridge sdllc local-ack
!
interface ethernet 0
 ip address 131.108.2.2 255.255.255.0
!
```

```
interface serial 0
  encapsulation sdlc-primary
  sdlc address c1
  sdllc traddr 4000.3174.0b0d 7 1 100
  sdllc partner 1000.5a7d.8123 c1
  !Must match TIC LOCADD [See NOTE 2]
  sdllc xid c1 017200c1
  !Must match VTAM IDBLK/IDNUM [See NOTE 4]
!
interface serial 1
  encapsulation sdlc-primary
  sdlc address c2
  sdllc traddr 0110.2222.3200 8 1 100
  sdllc partner 1000.5a7d.8123 c2
  !Must match TIC LOCADD [See NOTE 2]
  sdllc xid c2 017200c2
  !Must match VTAM IDBLK/IDNUM [See NOTE 4]
```

Configuration for Router C

```
source-bridge ring-group 100
source-bridge remote-peer 100 tcp 131.108.2.1
source-bridge remote-peer 100 tcp 131.108.2.2
source-bridge remote-peer 100 tcp 131.108.2.3
!
interface ethernet 0
ip address 131.108.2.3 255.255.255.0
!
interface serial 0
  encapsulation sdlc-primary
  sdlc address c3
  sdllc traddr 4000.3174.0c00 9 1 100
  sdllc partner 1000.5a7d.8123 c3
  Must match TIC LOCADD [See NOTE 2]
  sdllc xid c3 017200c3
  !Must match VTAM IDBLK/IDNUM [See NOTE 4]
```

QLLC Conversion Configuration Examples

The following sections provide QLLC conversion configuration examples:

- QLLC Conversion between a Single 37x5 and a Single 3x74 Example
- QLLC Conversion between a Single 37x5 and Multiple 3x74s Example
- QLLC Conversion between Multiple 37x5s and Multiple 3x74s Example
- QLLC Conversion between a Single 37x5 and Multiple 3x74s across an Arbitrary WAN Example
- NCP and VTAM Sysgen Parameters

The examples describe four increasingly complex QLLC conversion topologies and possible software configurations for each. Following the examples are sample NCP definitions that the 37x5 FEP in these topologies could use and VTAM definitions that the IBM host in these topologies could use to reflect the routers in the communication path.

QLLC Conversion between a Single 37x5 and a Single 3x74 Example

Figure 113, shown previously, illustrates the simplest QLLC conversion topology—a single 37x5 FEP on a Token Ring communicating with a single 3x74 cluster controller across an X.25 network. A router connects the Token Ring to the X.25 network. In Figure 113, notice that the router's X.25 interface is treated as a virtual ring for configuration purposes.

The following configuration file configures the Cisco IOS software to support the network topology shown in Figure 113:

```
source-bridge ring-group 100
!
interface serial 0
 encapsulation x25
 x25 address 31102120100
 x25 map qllc 0100.0000.0001 31104150101
 qllc srb 0100.0000.0001 201 100
!
! Allow the 3x74 to initiate the connection.
!
 qllc partner 0100.0000.0001 4000.0101.0132

interface tokenring 0
 source-bridge 1 1 100
```

In this configuration file, the **source-bridge ring-group** command defines a virtual ring number 100. The serial 0 interface that connects to the X.25 network is then configured for X.25 DTE operation using the **encapsulation x25** command and assigned the X.121 address of 31102120100 using the **x25 address** command. The **x25 map qllc** command associates the X.121 address of the remote X.25 device (31104150101) with a virtual Token Ring MAC address (0100.0000.0001) the Token Ring device will use to communicate with this remote X.25 device. The **qllc srb** command indicates that the virtual MAC address of the X.25 device will be used to communicate with the real MAC address of the Token Ring device.

The **qllc partner** command enables the software to open a connection to the local Token Ring device at MAC address 4000.0101.0132 on behalf of the remote X.25 device at virtual Token Ring MAC address 0100.0000.0001. The **source-bridge** command configures the router's Token Ring 0 interface for local source-route bridging by associating the router's virtual ring number 100 with the ring number (1) of the local Token Ring and the bridge number (1) that uniquely identifies this bridge interface.

QLLC Conversion between a Single 37x5 and Multiple 3x74s Example

Figure 114 shows a slightly more complex QLLC conversion topology. The same 37x5 FEP on a Token Ring connects through a router to an X.25 network, but communicates with multiple 3x74 cluster controllers through X.25.

Figure 114 QLLC Conversion between a Single 37x5 and Multiple 3x74s

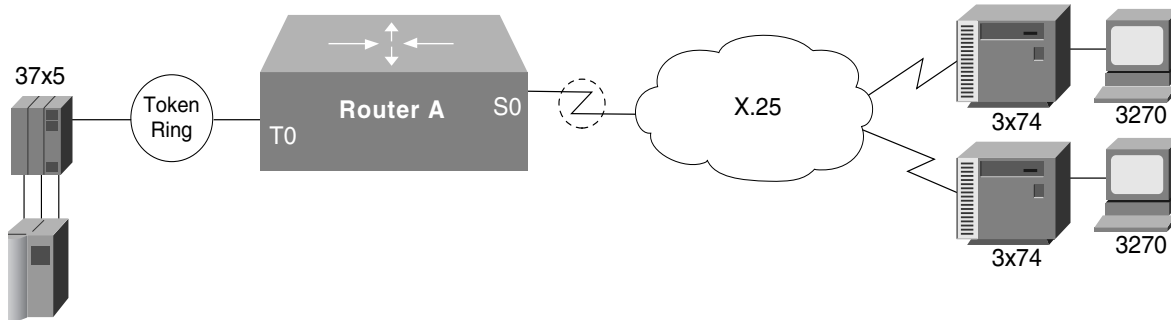

 = Virtual Ring

SI393a

The following configuration file configures the Cisco IOS software to support the network topology shown in Figure 114:

```

source-bridge ring-group 100
!
interface serial 0
 encapsulation x25
  x25 address 3137005469
!
! configure the first 3174
!
x25 map qllc 0000.0cff.0001 31370054111
!
! 1001 - virtual ring used by all qllc devices
! 100 - the virtual ring group
!
qllc srb 0000.0cff.0001 1001 100
qllc partner 0000.0cff.0001 4000.1160.0000
qllc xid 0000.0cff.0001 01710017
!
! configure the second 3174
!
x25 map qllc 0000.0cff.0002 313700543247
!
! 1001 - virtual ring used by all qllc devices
! 100 - the virtual ring group
!
qllc srb 0000.0cff.0002 1001 100
qllc partner 0000.0cff.0002 4000.1160.0000
qllc xid 0000.0cff.0002 01710017
!
interface tokenring 0
!
! Since this is a real bridge, we have to define the way it
! bridges to the Qllc virtual ring.
!
source-bridge 1 1 100
source-bridge spanning
    
```

QLLC Conversion between Multiple 37x5s and Multiple 3x74s Example

In the following example, two 3x74s on a Token Ring each attach to a different 37x5 on the other side of an X.25 network. Only one Token Ring interface is used. Do not create a bridge from the QLLC virtual ring (1001) to the physical Token Ring (1). Instead, define a virtual ring group (for example, 100).

```

interface serial 0
  encapsulation x25
  x25 address 3137005469
!
! configure the router for the first 3x74
!
x25 map qllc 0000.0cff.0001 31370054111
!
! 1001 - virtual ring used by all qllc devices
! 1 - the local Token Ring number
!
qllc srb 0000.0cff.0001 1001 1
qllc partner 0000.0cff.0001 4000.1160.0000
!
! configure the router for the second 3x74
!
x25 map qllc 0000.0cff.0002 31370053247
!
! 1001 - virtual ring used by all qllc devices
! 1 - the local Token Ring number
!
! Note that the partner's MAC address and XID are different from
! those in the first 3x74.
!
qllc srb 0000.0cff.0001 1001 1
qllc partner 0000.0cff.0002 4000.1161.1234
!
interface tokenring 0
!
! Since this is a real bridge, we have to define the way it bridges
! to the QLLC virtual ring.
!
source-bridge 1 1 1001
source-bridge spanning

```

QLLC Conversion between a Single 37x5 and Multiple 3x74s across an Arbitrary WAN Example

Figure 114, shown previously, includes an added arbitrary WAN in the communication path between the 37x5 FEP and the multiple 3x74 cluster controllers. The arbitrary WAN can be a multihop network, whereas QLLC conversion treats the X.25 network as a single-hop network.

In Figure 114, notice that the arbitrary WAN and the routers on either side of it form a single virtual ring, as configured using the **source-bridge ring-group** global configuration command.

In this configuration file, Router A uses an IP address of 131.108.2.2 and its Token Ring interface is attached to Token Ring 1. Because Router A connects to the Token Ring, it does not need to be configured for QLLC conversion. Router B, configured for QLLC conversion because it connects directly to the X.25 network through its serial interface, uses an X.121 address of 31102120100 and an IP address of 131.108.1.1. The 37x5 device uses a MAC address of 4000.0101.0132. The virtual MAC address of 0100.0000.0001 has been assigned to the 3x74 device.

Sample Configuration for Router A

The following configuration file configures the Router A in Figure 114:

```
source-bridge ring-group 100
source-bridge remote-peer 100 tcp 131.108.1.1 local-ack
source-bridge remote-peer 100 tcp 131.108.2.2 local-ack
!
interface ethernet 0
 ip address 131.108.3.3 255.255.255.0
!
interface tokenring 0
 ip address 131.108.2.2 255.255.255.0
 source-bridge 1 1 100
 source-bridge spanning
```

Sample Configuration for Router B

The following configuration file configures the Router B in Figure 114:

```
source-bridge ring-group 100
source-bridge remote-peer 100 tcp 131.108.1.1 local-ack
source-bridge remote-peer 100 tcp 131.108.2.2 local-ack
source-bridge qllc-local-ack
!
interface serial 0
 encapsulation x25
 x25 address 31102120100
 x25 map qllc 0100.0000.0001 31104150101
 x25 map qllc 0100.0000.0002 31104150102
 qllc srb 0100.0000.0001 201 100
 qllc srb 0100.0000.0002 201 100
!
! Allow the 3174 to initiate the connection.
!
qllc partner 0100.0000.0001 4000.0101.0132
qllc partner 0100.0000.0002 4000.0101.0132
!
interface ethernet 0
 ip address 131.108.1.1 255.255.255.0
```

NCP and VTAM Sysgen Parameters

The sample system generation (sysgen) parameters in this section show typical NCP and VTAM values that correspond with the Router A, Router B, and Router C configurations shown in Figure 112 and Figure 113 for SDLLC media translation and in Figure 114 for QLLC conversion.

IBM's ACF/NCP uses a function called NTRI (NCP/Token Ring Interconnection) to support Token Ring-attached SNA devices. NTRI also provides translation from Token Ring-attached SNA devices (Physical Units) to switched (dial-up) devices. VTAM provides the resolution for these devices in a Switched Major Node. VTAM treats these devices on NTRI logical lines as switched devices. (For more information consult IBM documentation *NCP/SSP/EP Resource Definition Reference*, SC30-3448-04.)

Using SDLLC, the Cisco IOS software translates SDLC leased line protocol into Token Ring LLC2 protocol, then the NTRI function in ACF/NCP translates Token Ring LLC2 protocol into an SNA switched protocol.

NCP Generation Definitions

```

*****
***          SAMPLES BASED ON ACF/NCP V5 R4.
***          NOT ALL NCP PARAMETERS ARE SHOWN
*****
*
*****
*          OPTIONS DEFINITION STATEMENT
*****
NCPOPTOPTIONS          NEWDEFN=YESNTRI GENERATION, MUST BE FIRST STMT
*
*****
*          BUILD MACRO
*****
NCPBU BUILD           LOCALTO=1.5,NTRI ACK TIMER FOR LOCAL TOKEN RINGS
                      REMOTTO=2.5,NTRI ACK TIMER FOR REMOTE TOKEN RINGS
                      USED IN SDLLC CONFIGURATIONS, NOTE 1
*
*****
*          DYNAMIC RECONFIGURATION POOL SPACE
*****
DRPOOLLUDRPOOL        NUMTYP2=50 RESERVE 50 LUS ON PU. T2 PUS
*
*****
*          PHYSICAL GROUP FOR NTRI TIC #1, DEFINITIONS FOR THE TOKEN RING
*          ADAPTER TO ESTABLISH PHYSICAL CONNECTIVITY
*****
EPHYG GROUP           ECLTYPE=PHYSICAL
*
EPHYL LINE            ADAPTER=TIC2,          TYPE OF ADAPTER
                      ADDRESS=(16,FULL),    INTERNAL FEP TIC ADDRESS
                      PORTADD=0,
                      LOCADD=10005a7d8123,TIC ADDRESS, NOTE 2
                      RCVBUFC=1440,
                      MAXTSL=2012,
                      TRSPEED=16           TOKEN RING SPEED
*
EPHYPPUPU
*
EPHYLULU              ISTATUS=INACTIVE
*
*****
*          NTRI PERIPHERAL LOGICAL LINE GROUP, LINE AND PU PAIRS ARE
*          GENERATED BY THE AUTOGEN PARAMETER.
*****
ELOGG GROUP           ECLTYPE=LOGICAL,
                      PHYPORT=0,
                      CALL=INOUT,
                      AUTOGEN=3           ONE PER SDLLC CONTROLLER,
                                           NOTE 3
*****

```

VTAM Definitions

```

*****
*          VTAM SWITCHED MAJOR NODE, BASED ON ACF/VTAM V3 R4.
*          THE CODING BELOW SUPPORTS DIAL IN OPERATION ONLY. TYPICALLY,
*          NTRI IMPLEMENTATIONS USE ONLY DIAL IN. IF DIAL OUT FROM AN
*          APPLICATION IS REQUIRED, PATH MACROS MUST BE USED. CONSULT
*          THE APPROPRIATE VTAM INSTALLATION REFERENCE MANUAL.
*****
VSWITCH  VBUILD          TYPE=SWNET
*
VPU1     PU              ADDR=13,          COULD BE ANYTHING (NOT USED)
          IDBLK=017,      XID PARM, NOTE 4
          IDNUM=200c1,    XID PARM, NOTE 4
          MAXOUT=7,
          MAXDATA=265,
          MODETAB=AMODETAB,
          DLOGMOD=US327X,
          PUTYPE=2,
          USSTAB=USS327X
*
VLU1A    LU              LOCADDR=2,
VLU1B    LU              LOCADDR=3
*
VPU2     PU              ADDR=13,          COULD BE ANYTHING (NOT USED)
          IDBLK=017,      XID PARM, NOTE 4
          IDNUM=200c2,    XID PARM, NOTE 4
          MAXOUT=7,
          MAXDATA=265,
          MODETAB=AMODETAB,
          DLOGMOD=US327X,
          PUTYPE=2,
          USSTAB=USS327X
*
VLU2A    LU              LOCADDR=2,
VLU2B    LU              LOCADDR=3
*
VPU3     PU              ADDR=13,          COULD BE ANYTHING (NOT USED)
          IDBLK=017,      XID PARM, NOTE 4
          IDNUM=200c3,    XID PARM, NOTE 4
          MAXOUT=7,
          MAXDATA=265,
          MODETAB=AMODETAB,
          DLOGMOD=US327X,
          PUTYPE=2,
          USSTAB=USS327X
*
VLU3A    LU              LOCADDR=2,
VLU3B    LU              LOCADDR=3
*

```

Notes

In these sample definitions:

- 1 REMOTTO is the NCP's T1 timer for remote Token Rings. All connections use RIF information and therefore look like remote Token Ring devices. The default is 2.5 seconds, which is adequate for most situations; however, when slow-speed links are used, this parameter should be reviewed to ensure enough time for link-level acknowledgments.
- 2 The LOCADD parameter defines the locally administered address of the TIC in the NCP. The Cisco IOS software, configured for SDLLC, will insert this address as the 802.5 destination address field in TEST and XID frames to establish connectivity and then in data frames during the session. The **sdllc partner** and **qllc partner** commands define this connection in the Cisco IOS software. Each SDLC control unit is defined with an **sdllc partner** or **qllc partner** command.
- 3 The AUTOGEN parameter specifies the number of LINE and PU pairs that are automatically generated by NDF (Network Definition Facility). Each controller requires a LINE and PU definition in the ELCTYPE LOGICAL group. These represent control block space in the NCP simulating switched line as described earlier.
- 4 The IDBLK and IDNUM parameters in VTAM are used to identify incoming connection requests. IDBLK is typically unique for each type of IBM device. IDNUM is any five hexadecimal digit combination. The Cisco routers configured for SDLLC or QLLC conversion must associate an IDBLK/IDNUM combination with a controller by using the **sdllc xid** or **qllc xid** command. If not using the **qllc xid** command, then IDBLK/IDNUM must agree with the values of the X.25 attached devices. During activation, an XID will be sent to the NCP containing the specific IDBLK/IDNUM. NCP will send these values to VTAM in an SNA command called REQCONT. VTAM will search its switched major nodes to find a match. If found, VTAM will establish sessions with the device by sending activation commands (ACTPU, ACTLU_s).

