

E1 R2 Signaling for the Cisco AS5800

The following sections are provided:

- Feature Summary on page 1
- Platforms on page 3
- Configuration Tasks on page 3
- Configuration Example on page 7
- Command Reference on page 9
- What to Do Next on page 19

Feature Summary

E1 R2 signaling, which was added to Cisco IOS Release 11.3(4)AA and later, is now available for the Cisco AS5800 access server. Only MICA modems support the R2 functionality.

E1 R2 Signaling

R2 signaling is an international signaling standard that is common to channelized E1 networks. There is no single standard for R2 signaling. The ITU-T Q.400-Q.490 recommendation defines R2, but a number of countries implement R2 in entirely different ways. Cisco Systems addresses this challenge by supporting many localized implementations of R2 signaling in its Cisco IOS software.

Cisco Systems' E1 R2 signaling default is ITU, which supports the following countries: Denmark, Finland, Germany, Russia (ITU variant), Hong Kong (ITU variant), and South Africa (ITU variant). The expression "ITU variant" means there are multiple R2 signaling types in the specified country.

Countries Supported

Cisco Systems also supports specific local variants of E1 R2 signaling in the following regions, countries, and corporations:

Note Country names and regions followed by an asterisk (*) were first supported in Cisco IOS Release 11.3(2)T.

- Argentina *
- Australia
- Brazil
- China
- Columbia
- Costa Rica
- East Europe (includes Croatia, Russia, and Slovak Republic) *
- Ecuador ITU *
- Ecuador LME *
- Greece
- Guatemala *
- Hong Kong (uses the China variant) *
- Indonesia
- Israel
- Korea
- Malaysia
- New Zealand
- Paraguay
- Peru *
- Philippines
- Saudi Arabia *
- Singapore
- South Africa (Panafel variant)*
- Telmex corporation (Mexico)
- Telnor corporation (Mexico)
- Thailand
- Uruguay

- Venezuela
- Vietnam *

Platforms

This feature is now supported on the Cisco AS5800.

Configuration Tasks

This section describes how to configure E1 R2 signaling.

R2 signaling is channelized E1 signaling used in Europe, Asia, and South America. It is equivalent to channelized T1 signaling in North America. There are two types of R2 signaling: line signaling and interregister signaling. R2 line signaling includes R2 digital, R2 analog, and R2 pulse. R2 interregister signaling includes R2 compelled, R2 non compelled, and R2 semi compelled. These signaling types are configured using the **cas-group (controller e1)** command.

Many countries have their own E1 R2 variant specifications, which supplement the ITU-T Q.400-Q.490 recommendation for R2 signaling. Unique E1 R2 signaling parameters for specific countries are set by issuing the **cas-custom channel** command followed by the **country name** command.

Cisco's implementation of R2 signaling has DNIS support turned on by default. If you enable the **ani** option, the collection of DNIS information is still performed. Specifying the **ani** option does not disable DNIS collection. DNIS is the number being called. ANI is the caller's number. For example, if you are configuring router A to call router B, then the DNIS number is assigned to router B, the ANI number is assigned to router A. ANI is similar to Caller ID.

Figure 1 shows a sample network topology for using E1 R2 signaling with a Cisco AS5800. All four controllers on the access server are configured with R2 digital signaling. Additionally, localized R2 country settings are enabled on the access server. For a sample configuration, see the "Configuration Example" section on page 7.

Figure 1 Service Provider using E1 R2 Signaling and a Cisco AS5800

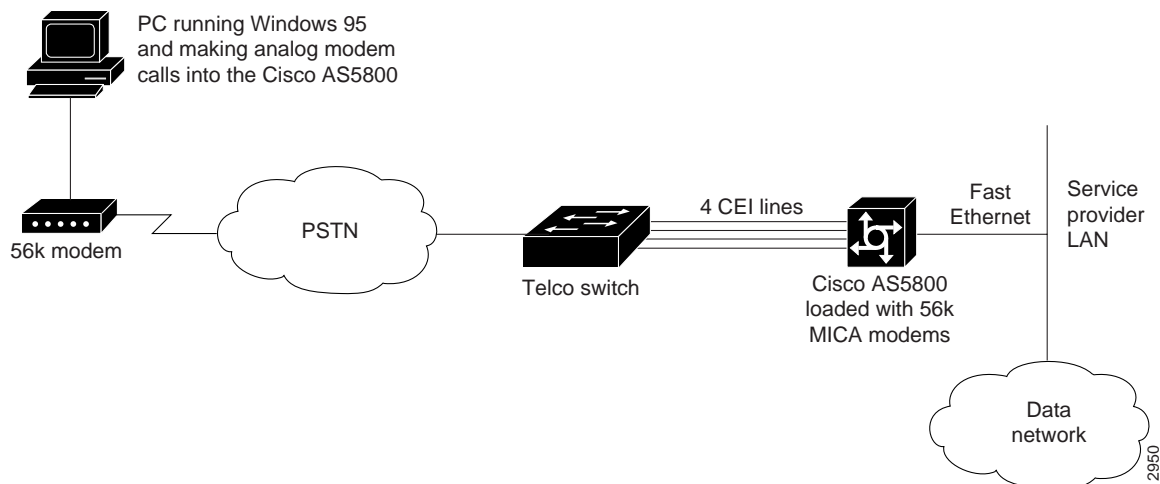

Configure

To configure E1 R2 signaling, use the following commands beginning in global configuration mode:

Step	Command	Purpose
1	controller e1 <i>number</i>	Specify the E1 controller that you want to configure with R2 signaling.
2	cas-group <i>channel timeslots range type</i> { r2-analog / r2-digital / r2-pulse } [dtmf r2-compelled [ani] r2-non-compelled [ani] r2-semi-compelled [ani]]	Configure R2 channel associated signaling on the E1 controller. For a complete description of the available R2 options, see the cas-group (controller e1) command reference page.
3	cas-custom <i>channel</i>	Enter cas-custom mode. In this mode, you can localize E1 R2 signaling parameters, such as specific R2 country settings for Hong Kong. For the customization to take effect, the <i>channel</i> number used in the cas-custom command must match the <i>channel</i> number specified by the cas-group command.
4	The following signaling commands are available: <ul style="list-style-type: none"> • ani-digits • answer-signal • caller-digits • category • country • default • dnis-digits • invert-abcd • ka • kd • metering • nc-congestion • unused-abcd 	(Optional) Customize E1 R2 signaling parameters for your E1 networking environment. Cisco strongly recommends that you specify your country type using the country command. Otherwise, the default will be ITU. See the cas-custom command reference page for more information about each signaling command.

For an E1 R2 configuration example, see the “Configuration Example” section on page 7.

Verify

To verify your E1 R2 signaling configuration, do the following:

- Enter the **show controller e1** command to view the status for all controllers, or enter the **show controller e1 number** command to view the status for a particular controller. Make sure the status indicates the controller is up (line 2 in the following example) and no alarms (line 4 in the following example) or errors (lines 9 and 10 in the following example) have been reported.

```
5800# show controller e1 0
E1 0 is up.
  Applique type is Channelized E1 - balanced
  No alarms detected.
  Version info of Slot 0: HW: 2, Firmware: 4, PLD Rev: 2

Manufacture Cookie is not programmed.

Framing is CRC4, Line Code is HDB3, Clock Source is Line Primary.
Data in current interval (785 seconds elapsed):
  0 Line Code Violations, 0 Path Code Violations
  0 Slip Secs, 0 Fr Loss Secs, 0 Line Err Secs, 0 Degraded Mins
  0 Errored Secs, 0 Bursty Err Secs, 0 Severely Err Secs, 0 Unavail Secs
Total Data (last 13 15 minute intervals):
  0 Line Code Violations, 0 Path Code Violations,
  0 Slip Secs, 12 Fr Loss Secs, 0 Line Err Secs, 0 Degraded Mins,
  0 Errored Secs, 0 Bursty Err Secs, 0 Severely Err Secs, 12 Unavail Secs
```

- Enter the **show modem csm [slot/modem-port]** command to view status for a specific modem:

```
5800# show modem csm 1/0
MODEM_INFO: slot 1, port 0, unit 0, tone r2-compelled, modem_mask=0x0000,
modem_port_offset=0
tty_hwidb=0x60E63E4C, modem_tty=0x60C16F04, oobp_info=0x00000000, modem_pool=0x60BC60CC
modem_status(0x0002): VDEV_STATUS_ACTIVE_CALL.
csm_state(0x0205)=CSM_IC5_CONNECTED, csm_event_proc=0x600CFF70, current call thru CAS
line
invalid_event_count=0, wdt_timeout_count=0
wdt_timestamp_started is not activated
wait_for_dialing:False, wait_for_bchan:False
pri_chnl=TDM_PRI_STREAM(s0, u3, c7), modem_chnl=TDM_MODEM_STREAM(s1, c0)
dchan_idb_start_index=0, dchan_idb_index=0, call_id=0x0239, bchan_num=6
csm_event=CSM_EVENT_DSX0_CONNECTED, cause=0x0000
ring_no_answer=0, ic_failure=0, ic_complete=3
dial_failure=0, oc_failure=0, oc_complete=0
oc_busy=0, oc_no_dial_tone=0, oc_dial_timeout=0
remote_link_disc=2, stat_busyout=2, stat_modem_reset=0
oobp_failure=0
call_duration_started=00:04:56, call_duration_ended=00:00:00,
total_call_duration=00:01:43
The calling party phone number =
The called party phone number = 9993003
total_free_rbs_timeslot = 0, total_busy_rbs_timeslot = 0,
total_dynamic_busy_rbs_timeslot = 0, total_static_busy_rbs_timeslot = 0,
min_free_modem_threshold = 0
```

Troubleshoot

If the connection does not come up, check the following:

- Loose wires, splices, connectors, shorts, bridge taps, and grounds
- Backwards transmit and receive

- Mismatched framing types (for example, CRC-4 verses no-CRC-4)
- Transmit and receive pair separation (crosstalk)
- Faulty line cards or repeaters
- Noisy lines (for example, power and crosstalk)

If you see errors on the line, or the line is going up and down, check the following:

- Mismatched line codes (HDB3 vs. AMI)
- Receive level
- Frame slips due to poor clocking plan

If you are still having trouble, enable the modem management Call Switching Module (CSM) debug mode using the **debug modem csm** command. The following is the debug output for an incoming call:

```
5800# debug modem csm 1/0
*May 15 04:05:46.675: VDEV_ALLOCATE: slot 2 and port 39 is allocated.

*May 15 04:05:46.675: CSM_RX_CAS_EVENT_FROM_NEAT:(04BF): EVENT_CALL_DIAL_IN at slot 2
and port 39

*May 15 04:05:46.675: CSM_PROC_IDLE: CSM_EVENT_DSX0_CALL at slot 2, port 39

*May 15 04:05:46.675: Mica Modem(2/39): Configure(0x0)
*May 15 04:05:46.675: Mica Modem(2/39): Configure(0x3)
*May 15 04:05:46.675: Mica Modem(2/39): Configure(0x6)
*May 15 04:05:46.675: Mica Modem(2/39): Call Setup
*May 15 04:05:46.891: Mica Modem(2/39): State Transition to Call Setup
*May 15 04:05:46.891: Mica Modem(2/39): Went offhook
*May 15 04:05:46.891: CSM_PROC_IC1_RING: CSM_EVENT_MODEM_OFFHOOK at slot 2, port 39
.
.
.
```

When the E1 controller comes up, you will see the following messages:

```
%CONTROLLER-3-UPDOWN: Controller E1 0, changed state to up
It also shows these messages for individual timeslots:
%DSX0-5-RBSLINEUP: RBS of controller 1 timeslot 1 is up
%DSX0-5-RBSLINEUP: RBS of controller 1 timeslot 2 is up
%DSX0-5-RBSLINEUP: RBS of controller 1 timeslot 3 is up
%DSX0-5-RBSLINEUP: RBS of controller 1 timeslot 4 is up
%DSX0-5-RBSLINEUP: RBS of controller 1 timeslot 5 is up
%DSX0-5-RBSLINEUP: RBS of controller 1 timeslot 6 is up
%DSX0-5-RBSLINEUP: RBS of controller 1 timeslot 7 is up
%DSX0-5-RBSLINEUP: RBS of controller 1 timeslot 8 is up
.
.
.
```

Configuration Example

This section shows a sample configuration of E1 R2 signaling. In most cases, the same R2 signaling type is configured on each E1 controller. The following example configures R2 signaling and customizes R2 parameters on controller E1 2 of a Cisco AS5800:

Step 1 Enter global configuration mode using the **configure terminal** command:

```
as5800# configure terminal
Enter configuration commands, one per line. End with CNTL/Z.
```

Step 2 Specify the E1 controller that you want to configure with R2 signaling using the **controller e1 number** global configuration command. A controller informs the access server how to distribute or provision individual timeslots for a connected channelized E1 line. You must configure one E1 controller for each E1 line.

```
as5800(config)# controller e1 2
```

Step 3 Configure channel-associated signaling with the **cas-group channel timeslots range type signal** command. The signaling type forwarded by the connecting telco switch must match the signaling configured on the Cisco AS5800. The Cisco IOS configuration options are **r2-analog**, **r2-digital**, or **r2-pulse**.

```
as5800(config-controller)# cas-group 1 timeslots 1-31 type ?
e&m-fgb          E & M Type II FGB
e&m-fgd          E & M Type II FGD
e&m-immediate-start E & M Immediate Start
fxs-ground-start FXS Ground Start
fxs-loop-start   FXS Loop Start
p7              P7 Switch
r2-analog       R2 ITU Q411
r2-digital      R2 ITU Q421
r2-pulse        R2 ITU Supplement 7
sas-ground-start SAS Ground Start
sas-loop-start  SAS Loop Start
```

The following example specifies R2 ITU Q421 digital line signaling (**r2-digital**). This example also specifies R2 compelled register signaling and provisions the ANI ADDR option.

```
as5800(config-controller)# cas-group 1 timeslots 1-31 type r2-digital
r2-compelled ani
as5800(config-controller)#
%DSX0-5-RBSLINEUP: RBS of controller 0 timeslot 1 is up
%DSX0-5-RBSLINEUP: RBS of controller 0 timeslot 2 is up
%DSX0-5-RBSLINEUP: RBS of controller 0 timeslot 3 is up
%DSX0-5-RBSLINEUP: RBS of controller 0 timeslot 4 is up
%DSX0-5-RBSLINEUP: RBS of controller 0 timeslot 5 is up
%DSX0-5-RBSLINEUP: RBS of controller 0 timeslot 6 is up
%DSX0-5-RBSLINEUP: RBS of controller 0 timeslot 7 is up
%DSX0-5-RBSLINEUP: RBS of controller 0 timeslot 8 is up
%DSX0-5-RBSLINEUP: RBS of controller 0 timeslot 9 is up
%DSX0-5-RBSLINEUP: RBS of controller 0 timeslot 10 is up
%DSX0-5-RBSLINEUP: RBS of controller 0 timeslot 11 is up
%DSX0-5-RBSLINEUP: RBS of controller 0 timeslot 12 is up
%DSX0-5-RBSLINEUP: RBS of controller 0 timeslot 13 is up
%DSX0-5-RBSLINEUP: RBS of controller 0 timeslot 14 is up
%DSX0-5-RBSLINEUP: RBS of controller 0 timeslot 15 is up
%DSX0-5-RBSLINEUP: RBS of controller 0 timeslot 17 is up
```

```
%DSX0-5-RBSLINEUP: RBS of controller 0 timeslot 18 is up
%D SX0-5-RBSLINEUP: RBS of controller 0 timeslot 19 is up
%D SX0-5-RBSLINEUP: RBS of controller 0 timeslot 20 is up
%D SX0-5-RBSLINEUP: RBS of controller 0 timeslot 21 is up
%D SX0-5-RBSLINEUP: RBS of controller 0 timeslot 22 is up
%D SX0-5-RBSLINEUP: RBS of controller 0 timeslot 23 is up
%D SX0-5-RBSLINEUP: RBS of controller 0 timeslot 24 is up
%D SX0-5-RBSLINEUP: RBS of controller 0 timeslot 25 is up
%D SX0-5-RBSLINEUP: RBS of controller 0 timeslot 26 is up
%D SX0-5-RBSLINEUP: RBS of controller 0 timeslot 27 is up
%D SX0-5-RBSLINEUP: RBS of controller 0 timeslot 28 is up
%D SX0-5-RBSLINEUP: RBS of controller 0 timeslot 29 is up
%D SX0-5-RBSLINEUP: RBS of controller 0 timeslot 30 is up
%D SX0-5-RBSLINEUP: RBS of controller 0 timeslot 31 is up
```

Note For a description of the supported R2 signaling options, see the **cas-group (controller e1)** command reference page. The actual R2 channel-associated signaling is configured on the 16th timeslot, which is the reason the timeslot does not come up in the example output.

Step 4 Customize some of the E1 R2 signaling parameters with the **cas-custom channel** controller configuration command. This example specifies the default R2 settings for Argentina. See the **cas-custom** command reference page for a detailed description of these options.

```
as5800(config-controller)# cas-custom 1
as5800(config-ctrl-cas)# ?
CAS custom commands:
  ani-digits      Expected number of ani digits
  answer-signal  Answer signal to be used
  caller-digits  Digits to be collected before requesting CallerID
  category       Category signal
  country        Country Name
  default        Set a command to its defaults
  dnis-digits    Expected number of DNIS digits
  exit           Exit from cas custom mode
  invert-abcd    invert the ABCD bits before tx and after rx
  ka             KA Signal
  kd             KD Signal
  metering       R2 network is sending metering signal
  nc-congestion  Non Compelled Congestion signal
  no            Negate a command or set its defaults
  unused-abcd   Unused ABCD bit values

as5800(config-ctrl-cas)# country ?
  argentina      Argentina
  australia      Australia
  brazil         Brazil
  china          China
  columbia       Columbia
  .
  .
  .
as5800(config-ctrl-cas)# country argentina ?
  use-defaults  Use Country defaults
  <cr>

as5800(config-ctrl-cas)# country argentina use-defaults
```

Note Cisco highly recommends that you specify your country's default settings. To display a list of supported countries, issue the **country ?** command. The default setting for all countries is ITU.

Command Reference

This section documents new or modified commands. All other commands used with this feature are documented in the Cisco IOS Release 11.3 command references.

The following commands are modified:

- **cas-custom**
- **cas-group (controller e1)**

cas-custom

To customize E1 R2 signaling parameters for a particular E1 channel group on a channelized E1 line, use the **cas-custom** controller configuration command. Use the **no** form of this command to disable the signaling customization.

```
cas-custom channel  
no cas-custom channel
```

Syntax Description

<i>channel</i>	Specifies a single channel group number, which can be between 0 and 30. This channel group number must match the channel number specified in the cas-group command.
----------------	--

Default

No customized signaling parameters are set. If you do not specify a country name using the **country name** command, which is described in Table 1, ITU is the selected default signal.

Command Mode

Controller configuration

Usage Guidelines

This command first appeared in Cisco IOS Release 11.2 P.

The customization parameters set by the **cas-custom channel** command are applied to the same channel group number used in the **cas-group channel timeslots range type signal** command. These channel group numbers must match. Otherwise, the customized features specified by the **cas-custom** command will not be applied to the **cas-group** command's configuration. The signaling customization will not take effect. See Example 1.

However, you will not need to configure or set more than one channel group number per E1 line in most cases. Though rarely used, it is possible to split a single E1 (timeslots 1 to 31) into two groups (for example, 1 to 15 on group 1 and timeslots 17 to 31 in group 2).

Cisco strongly recommends that you use the **use-defaults** option when specifying a particular country type. See the **country name** command in Table 1. This additional keyword ensures that all the local country settings are correctly enabled. For example, issue the **country greece use-defaults** command. If the **use-defaults** option is not specified, generic ITU will be the default setting for all countries. See Example 2.

You can configure the system to deviate from a country's default settings as defined by Cisco. To do this, choose from the following list of commands described in Table 1: **ani-digits min number max number**, **answer-signal {group-a | group-b} number**, **caller-digits number**, **category number**, **dnis-digits min number max number**, **invert-abcd**, **ka number**, **kd number**, **metering**, **nc-congestion**, and **unused-abcd value**. To return a country back to its country specific default settings, issue the **country name use-defaults** command. To return a country back to the ITU standard, issue the **default country name use-defaults** command. See Example 3 and Example 4.

Note Only integrated MICA modems support E1 R2 signaling on Cisco access servers.

Table 1 shows a list of command options in cas-custom mode, which is used to customize R2 signaling settings.

Table 1 Available Commands in cas-custom Mode

CAS Custom Command	Purpose
ani-digits <i>min number max number</i>	Expected number of ANI digits. The minimum number of collected digits is set by min number . Replace <i>number</i> with a value between 0 and 64. The maximum number of collected digits is set by max number . Replace <i>number</i> with a value between 5 and 64. The default is 0 digits, which is the ITU default.
answer-signal { group-a group-b } <i>number</i>	Answer signal to be used. You can specify the group A signal or the group B signal. The signal <i>number</i> can be 1 to 15. Default is group-b 6, which is the ITU default.
caller-digits <i>number</i>	Specifies the number of digits the access server needs to collect before it requests ANI or CallerID information. The digits can be from 1 to 10. Default is 1, which is the ITU default.
category <i>number</i>	Specifies the type of incoming call, which is mapped to a group signal <i>number</i> . Signal numbers from 1 to 15 are available. Default is 1, which is the ITU default.
country <i>name</i>	<p>Specifies local country settings to use with R2 signaling. Replace the <i>name</i> variable with one of the following supported country names. Cisco strongly recommends that you include the use-defaults option, which enables the default settings for a specific country. Default country setting is ITU.</p> <ul style="list-style-type: none"> • argentina [use-defaults] • australia [use-defaults] • brazil [use-defaults] • china [use-defaults] • columbia [use-defaults] • costarica [use-defaults] • easturope [use-defaults] <p>The easturope option supports Croatia, Russia, and the Slovak Republic.</p> <ul style="list-style-type: none"> • ecuador-itu [use-defaults] • ecuador-lme [use-defaults] • greece [use-defaults] • guatemala [use-defaults] • hongkong-china [use-defaults] <p>The Hong Kong options uses the China variant.</p>

Table 1 Available Commands in cas-custom Mode (Continued)

CAS Custom Command	Purpose
	<ul style="list-style-type: none"> • indonesia [use-defaults] • israel [use-defaults] • itu ITU is the signaling default. ITU provides support for the following list of countries: Denmark, Finland, Germany, Russia (ITU variant), Hong Kong (ITU variant), and South Africa (ITU variant). The expression “ITU variant” means that there are multiple R2 signaling types deployed in the specified country, but Cisco supports the ITU variant. • korea [use-defaults] • malaysia [use-defaults] • newzealand [use-defaults] • paraguay [use-defaults] • peru [use-defaults] • philippines [use-defaults] • saudi Arabia [use-defaults] • singapore [use-defaults] • southafrica-panaftel [use-defaults] The South Africa option uses the Panaftel variant. • telmex [use-defaults] • telnor [use-defaults] The telemex and telnor options are used in Mexico. • thailand [use-defaults] • uruguay [use-defaults] • venezuela [use-defaults] • vietnam [use-defaults]
default	Sets a command to its default setting.
dnis-digits <i>min number max number</i>	Expected number of DNIS digits. The minimum number of collected digits is set by min number . Replace <i>number</i> with a value between 0 and 64. The maximum number of collected digits is set by max number . Replace <i>number</i> with a value between 5 and 64. The default is 0 digits, which is the ITU default.
exit	Takes you out of cas custom mode.
invert-abcd	Inverts the ABCD bits before tx and after rx. This feature is disabled by default, which is the ITU default.
ka <i>number</i>	Specifies the KA signal code. You can choose 1 to 15. Default is 0, which is the ITU default.
kd <i>number</i>	Specifies the KD signal code. You can choose 1 to 15. Default is 0, which is the ITU default.
metering	Specifies sending a metering pulse when the access server is making an outgoing call. Metering is turned off by default, which is the ITU default.

Table 1 Available Commands in cas-custom Mode (Continued)

CAS Custom Command	Purpose
nc-congestion	Specifies the noncompelled congestion signal. This signal is sent to the central office when the access server is congested and cannot accept the call. The default is B4, which is the ITU default.
no	Negates a command or sets its defaults.
unused-abcd <i>value</i>	Specifies unused ABCD bit values, which can have a 0 or 1 bit value. This feature is disabled by default, which is the ITU default.

Example 1

The following example displays the available signaling parameters after you enter cas-custom mode. Notice that the same channel group 1 is specified in the **cas-group** command and the **cas-custom** command.

```

router# configure terminal
Enter configuration commands, one per line. End with CNTL/Z
router(config)# controller e1 1
router(config-controller) cas-group 1 timeslots 1-31 type r2-digital r2-compelled
router(config-controller) cas-custom 1
router(config-ctrl-cas)# ?
CAS custom commands:
  ani-digits      Expected number of ANI digits
  answer-signal  Answer signal to be used
  caller-digits  Digits to be collected before requesting CallerID
  category       Category signal
  country        Country Name
  default        Set a command to its defaults
  dnis-digits    Expected number of DNIS digits
  exit           Exit from cas custom mode
  invert-abcd    invert the ABCD bits before tx and after rx
  ka             KA Signal
  kd            KD Signal
  metering       R2 network is sending metering signal
  nc-congestion  Non Compelled Congestion signal
  no            Negate a command or set its defaults
  unused-abcd    Unused ABCD bit values

```

Example 2

You can localize your R2 configuration for a specific country. Don't forget to include the **use-defaults** option as described in Table 1. For example, use the **country argentina use-defaults** command for a R2 scenario in Argentina.

```

router(config-ctrl-cas)# country ?
  argentina      Argentina
  australia      Australia
  brazil         Brazil
  china          China
  columbia       Columbia
  costarica      Costa Rica
  easteuropa     East Europe
  ecuador-itu    Ecuador ITU
  ecuador-lme    Ecuador LME
  greece         Greece
  guatemala      Guatemala

```

hongkong-china	Hong Kong (China variant)
indonesia	Indonesia
israel	Israel
itu	ITU
korea	Korea
malaysia	Malaysia
newzealand	New Zealand
paraguay	Paraguay
peru	Peru
philippines	Philippines
saudiarabia	Saudi Arabia
singapore	Singapore
southafrica-panaftel	South Africa Panaftel
telmex	Telmex
telnor	Telnor
thailand	Thailand
uruguay	Uruguay
venezuela	Venezuela
vietnam	Vietnam

```
router(config-ctrl-cas)# country argentina ?
  use-defaults  Use Country defaults
  <cr>

router(config-ctrl-cas)# country argentina use-defaults
```

Example 3

The following example customizes the signaling for channel group 1. The configuration collects 3 digits before it requests ANI information for analog calls received on a Cisco AS5800 in Argentina.

```
router(config-controller)# cas-custom 1
router(config-ctrl-cas)# country argentina use-defaults
router(config-ctrl-cas)# caller-digits 3
router(config-controller)# ^z
router(config)#
```

Example 4

Because cas-custom mode gives you the flexibility to customize R2 parameters, the margin for user error increases. Therefore, the Cisco IOS software enables you to return a country back to its default R2 settings using the **use-defaults** option. The following example begins by bringing up Argentina's default settings, changing a few customization parameters, then returning the Argentina R2 setting back to its original state.

```
router(config-ctrl-cas)# country argentina use-defaults
router(config-ctrl-cas)# caller-digits 3
router(config-ctrl-cas)# unused-abcd 1
router(config-ctrl-cas)# metering
router(config-ctrl-cas)# country argentina use-defaults
```

Related Command

cas-group (controller E1)

cas-group (controller e1)

To configure channel associated signaling on an E1 controller, use the **cas-group** controller configuration command. Use the **no** form of this command to disable channel associated signaling for one or more timeslots.

```
cas-group channel timeslots range type signal
no cas-group channel timeslots range type signal
```

Syntax Description

<i>channel</i>	Specifies a single channel group number. Replace the <i>channel</i> variable with a number between 0 and 30.
timeslots <i>range</i>	Specifies a timeslot range, which can be from 1 to 31. You can specify a timeslot range (for example, 1-31), individual timeslots separated by commas (for example 1, 3, 5), or a combination of the two (for example 1-14, 15, 17-31). The 16th time slot is reserved for out-of-band signaling.
type <i>signal</i>	Specifies the type of channel associated signaling. Configure the signal type that your central office uses. Replace the <i>signal</i> variable with one of the following signal types: <ul style="list-style-type: none"> • e&m-fgb [dtmf [dnis] mf [dnis]]—Specifies ear and mouth channel signaling with feature group B support, which includes the wink start protocol. The optional signal tones are DTMF and MF with the option of provisioning DNIS. • e&m-fgd—Specifies ear and mouth channel signaling with feature group D support, which includes the wink start protocol. • e&m-immediate-start—Specifies ear and mouth channel signaling with immediate start support. • fxs-ground-start—Specifies Foreign Exchange Station ground start signaling support. • fxs-loop-start— Specifies Foreign Exchange Station loopstart signaling support. • p7— Specifies the P7 switch type. • sas-ground-start—Specifies Special Access Station ground start signaling support. • sas-loop-start—Specifies Special Access Station loopstart signaling support. • r2-analog [dtmf r2-compelled [ani] r2-non-compelled [ani] r2-semi-compelled [ani]] • r2-digital [dtmf r2-compelled [ani] r2-non-compelled [ani] r2-semi-compelled [ani]] • r2-pulse [dtmf r2-compelled [ani] r2-non-compelled [ani] r2-semi-compelled [ani]]

The following descriptions are provided for the previous three R2 syntax bullets:

r2-analog—Specifies R2 ITU Q411 analog line signaling, which reflects the on/off switching of a tone in frequency-division multiplexing circuits (before TDM circuits were created). The tone is used for line signaling.

r2-digital—Specifies R2 ITU Q421 digital line signaling, which is the most common signaling configuration. The A and B bits are used for line signaling.

r2-pulse—Specifies R2 ITU supplement 7 pulse line signaling, which is a transmitted pulse that indicates a change in the line state.

dtmf—Specifies the DTMF tone signaling.

r2-compelled [ani]—Specifies R2 compelled register signaling. You can also specify provisioning the ANI addr option.

r2-non-compelled [ani]—Specifies R2 noncompelled register signaling.

r2-semi-compelled [ani]—Specifies R2 semicompelled register signaling.

Default

No channel associated signaling is configured on the controller. All R2 signaling types have DNIS turned on by default.

Command Mode

Controller configuration

Usage Guidelines

This command first appeared in Cisco IOS Release 11.2 P.

Use this command to configure support for incoming and outgoing call signals (such as on-hook and off-hook) on each E1 controller.

If you specify the timeslot range 1-31, the system software automatically uses the 16th timeslot to transmit the channel associated signaling.

The signaling you configure on the access server must match the signaling used by the central office. For example if the central office switch is forwarding R2 analog signaling to a Cisco AS5800, then the access server's E1 controller must also be configured for R2 analog signaling (**r2-analog**).

All R2 signaling options have DNIS support turned on by default. If you enable the **ani** option, the collection of DNIS information is still performed. Specifying the **ani** option does not disable DNIS. DNIS is the number being called. ANI is the caller's number. For example, if you are configuring router A to call router B, then the DNIS number is router B, the ANI number is router A. ANI is very similar to Caller ID.

To customize the R2 signaling parameters, refer to the **cas-custom** controller configuration command. When you enable the **cas-group** command, the **cas-custom** command is automatically setup to be polled for configuration information. However, unless you enable or turn on specific features with the **cas-custom** command, the cas-custom feature has an empty set of signaling parameters.

Note Only integrated MICA modems support E1 R2 signaling on Cisco access servers.

DNIS is automatically collected for modem pools and R2 tone signaling. You do not need to specify the collection of DNIS information with the **cas-group** command. However, if you are using non-R2 tone signaling, the system must be manually configured to collect DNIS information. For non-R2 cas signaling, DNIS collection is done only for E&M-fgb.

Examples

In most cases, you will configure the same channel associated signaling on each E1 controller. The following examples configure signaling and customized parameters on controller E1 2 using the **cas-group** and **cas-custom** controller configuration commands.

The actual channel associated signaling is configured on the 16th timeslot, which is the reason why this timeslot does not come up in the following output.

```
router# configure terminal
Enter configuration commands, one per line. End with CNTL/Z.
router(config)# controller e1 2
router(config-controller)# cas-group 1 timeslots 1-31 type r2-digital r2-compelled ani
router(config-controller)#
%DSX0-5-RBSLINEUP: RBS of controller 0 timeslot 1 is up
%DSX0-5-RBSLINEUP: RBS of controller 0 timeslot 2 is up
%DSX0-5-RBSLINEUP: RBS of controller 0 timeslot 3 is up
%DSX0-5-RBSLINEUP: RBS of controller 0 timeslot 4 is up
%DSX0-5-RBSLINEUP: RBS of controller 0 timeslot 5 is up
%DSX0-5-RBSLINEUP: RBS of controller 0 timeslot 6 is up
%DSX0-5-RBSLINEUP: RBS of controller 0 timeslot 7 is up
%DSX0-5-RBSLINEUP: RBS of controller 0 timeslot 8 is up
%DSX0-5-RBSLINEUP: RBS of controller 0 timeslot 9 is up
%DSX0-5-RBSLINEUP: RBS of controller 0 timeslot 10 is up
%DSX0-5-RBSLINEUP: RBS of controller 0 timeslot 11 is up
%DSX0-5-RBSLINEUP: RBS of controller 0 timeslot 12 is up
%DSX0-5-RBSLINEUP: RBS of controller 0 timeslot 13 is up
%DSX0-5-RBSLINEUP: RBS of controller 0 timeslot 14 is up
%DSX0-5-RBSLINEUP: RBS of controller 0 timeslot 15 is up
%DSX0-5-RBSLINEUP: RBS of controller 0 timeslot 17 is up
%DSX0-5-RBSLINEUP: RBS of controller 0 timeslot 18 is up
%DSX0-5-RBSLINEUP: RBS of controller 0 timeslot 19 is up
%DSX0-5-RBSLINEUP: RBS of controller 0 timeslot 20 is up
%DSX0-5-RBSLINEUP: RBS of controller 0 timeslot 21 is up
%DSX0-5-RBSLINEUP: RBS of controller 0 timeslot 22 is up
%DSX0-5-RBSLINEUP: RBS of controller 0 timeslot 23 is up
%DSX0-5-RBSLINEUP: RBS of controller 0 timeslot 24 is up
%DSX0-5-RBSLINEUP: RBS of controller 0 timeslot 25 is up
%DSX0-5-RBSLINEUP: RBS of controller 0 timeslot 26 is up
%DSX0-5-RBSLINEUP: RBS of controller 0 timeslot 27 is up
%DSX0-5-RBSLINEUP: RBS of controller 0 timeslot 28 is up
%DSX0-5-RBSLINEUP: RBS of controller 0 timeslot 29 is up
%DSX0-5-RBSLINEUP: RBS of controller 0 timeslot 30 is up
%DSX0-5-RBSLINEUP: RBS of controller 0 timeslot 31 is up
```

The following example shows all the supported E1 signaling types on a Cisco AS5800:

```
router(config-controller)# cas-group 1 timeslots 1-31 type ?
e&m-fgb          E & M Type II FGB
e&m-fgd          E & M Type II FGD
e&m-immediate-start  E & M Immediate Start
fxs-ground-start  FXS Ground Start
fxs-loop-start    FXS Loop Start
p7              P7 Switch
r2-analog        R2 ITU Q411
r2-digital        R2 ITU Q421
r2-pulse         R2 ITU Supplement 7
sas-ground-start SAS Ground Start
sas-loop-start   SAS Loop Start

router(config-controller)# cas-group 1 timeslots 1-31 type r2-analog ?
dtmf             DTMF tone signalling
r2-compelled     R2 Compelled Register Signalling
r2-non-compelled R2 Non Compelled Register Signalling
r2-semi-compelled R2 Semi Compelled Register Signalling
<cr>
```

R2 signaling parameters can be customized with the **cas-custom** controller configuration command:

```
router(config-controller)# cas-custom 1
router(config-ctrl-cas)# ?
CAS custom commands:
caller-digits  Digits to be collected before requesting CallerID
category       Category signal
country        Country Name
default        Set a command to its defaults
exit           Exit from cas custom mode
invert-abcd    invert the ABCD bits before tx and after rx
metering       R2 network is sending metering signal
nc-congestion  Non Compelled Congestion signal
no             Negate a command or set its defaults
```

What to Do Next

For additional dial-related software configuration information, see the following publications:

- *Dial Solutions Configuration Guide* (Cisco IOS Release 11.3)
- *Cisco AS5800 Universal Access Server Software Configuration Guide*

