

# Enterprise Dial Scenarios and Configurations

---

This chapter provides sample hardware and software configurations for specific dial scenarios used by enterprises. Each configuration is designed to support IP network traffic with basic security for the specified scenario.

The following scenarios are described:

- Scenario 1—Remote Offices and Telecommuters Dialing In to a Central Site
- Scenario 2—Bidirectional Dial Networking between a Central Site and Remote Offices or Telecommuters
- Scenario 3—Telecommuters Dialing In to a Mixed Protocol Environment

---

**Note** If you use Token card-based security in your dial network, Cisco recommends that you enable PAP authentication and disable multilink to maximize dial-in performance.

---

## Scalability and Design Issues

You need to consider scalability and design issues when building dial enterprise networks. As the number of company employees increases, the number of remote users needing to dial in increases. A scalable dial solution is needed as the demand for dial-in ports grows. For example, it is not uncommon for a fast-growing enterprise to grow from a demand of 100 modems to 250 modems in less than one year.

You should always maintain a surplus of dial-in ports to accommodate company growth and occasional increases in access demand. In the early stages of a fast-growing company that has 100 modems installed for 6,000 registered remote users, only 50 to 60 modems might be active at the same time. One year later, however, 250 modems might be installed to support 10,000 registered token card holders.

During special company occasions, such as a worldwide convention, demand for remote access can also increase significantly. During such an activity, dial-in lines are heavily stressed throughout the day and evening by remote sales people using laptops to access e-mail and share files. This behavior is indicative of sales people working away from their home territories or sales offices. Network administrators need to prepare for these remote access bursts, which cause significant increases for remote access demand.

## Remote Offices and Telecommuters Dialing In to a Central Site

Employees stationed in remote offices or disparate locations often dial in to central sites or headquarter offices to download or upload files and check e-mail. These employees often dial in to the corporate network from a remote office LAN using ISDN or from another location such as a hotel room using a modem.

The following types of remote enterprise users dial in to enterprise networks:

- Full time telecommuters—Employees using stationary workstations to dial in from a small office or home office (SOHO), making ISDN connections with terminal adapters or PC cards through the public telephone network, and operating at higher speeds over the network, which rules out the need for a modem.
- Travelers—Employees such as sales people who are not in a steady location for more than 30% of the time, usually dial in to the network with a laptop and modem through the public telephone network, and primarily access the network to check e-mail or transfer a few files.
- Workday extenders—Employees who primarily work in the company office, occasionally dial in to the enterprise with a mobile or stationary workstation plus modem, and primarily access the network to check e-mail or transfer a few files.

Remote office LANs typically dial in to other networks using ISDN, which provides a larger bandwidth that cannot be attained over analog telephone connections. Remote offices that use Frame Relay to access other networks require a more costly dedicated link.

Connections initiated by remote offices or telecommuters are brought up on an as-needed basis, which results in substantial cost savings for the company. In dial-on-demand scenarios, users are not connected for long periods of time. The number of remote nodes requiring access is relatively low, and the completion time for the dial-in task is short.

Central or headquarter sites typically do not dial out to the remote LANs or devices. Instead, central sites respond to calls. Remote sites initiate calls. For example, a field sales office might use ISDN to dial in to and browse a central site's intranet. Additionally a warehouse comprised of five employees can use ISDN to log in to a remote network server to download or upload product order information. For an example of bidirectional dialing, see the section "Bidirectional Dial Networking between a Central Site and Remote Offices or Telecommuters."

---

**Note** When using dial-on-demand routing, you must make a fundamental decision about how your routing will be set up: to use static routes or snapshot routing. For IP-only configurations, static routes are commonly used for remote dial-in. For IPX networking, snapshot routing is often used to minimize configuration complexity.

---

Figure 17 shows an example of a remote office placing digital calls in to a central site network. The remote office router can be any Cisco router with a BRI physical interface, such as a Cisco 766 or Cisco 1604. The central office gateway router can be any Cisco router that supports PRI connections, such as a Cisco 3600 series, 4000 series, or 7000 series router.

**Figure 17 Remote Office Dialing In to a Central Site**

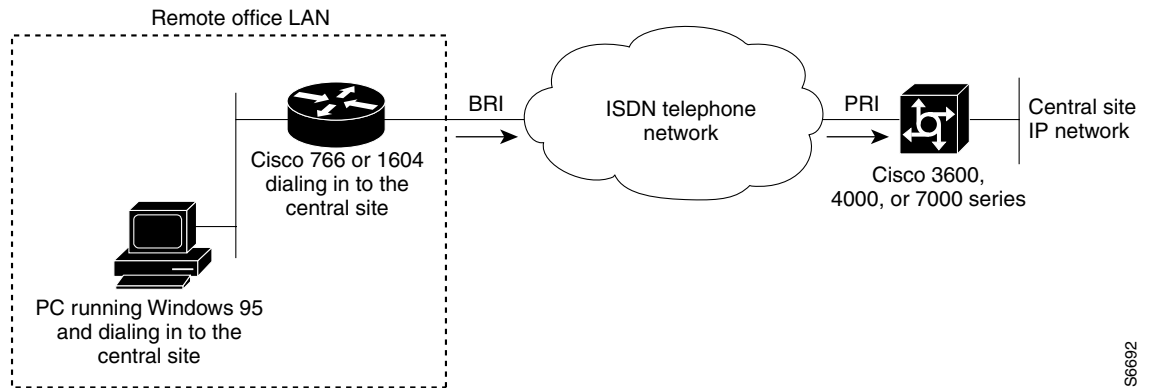

S6692

Figure 18 shows an example of a remote office and telecommuter dialing in to a central site. The remote office places digital calls. The telecommuter places analog calls. The remote office router can be any Cisco router with a BRI interface, such as a Cisco 766, 1604, or 2503. The central office gateway router is a Cisco AS5200 or Cisco 3640, which supports both PRI and analog connections.

**Figure 18 Remote Office and Telecommuter Dialing In to a Central Site**

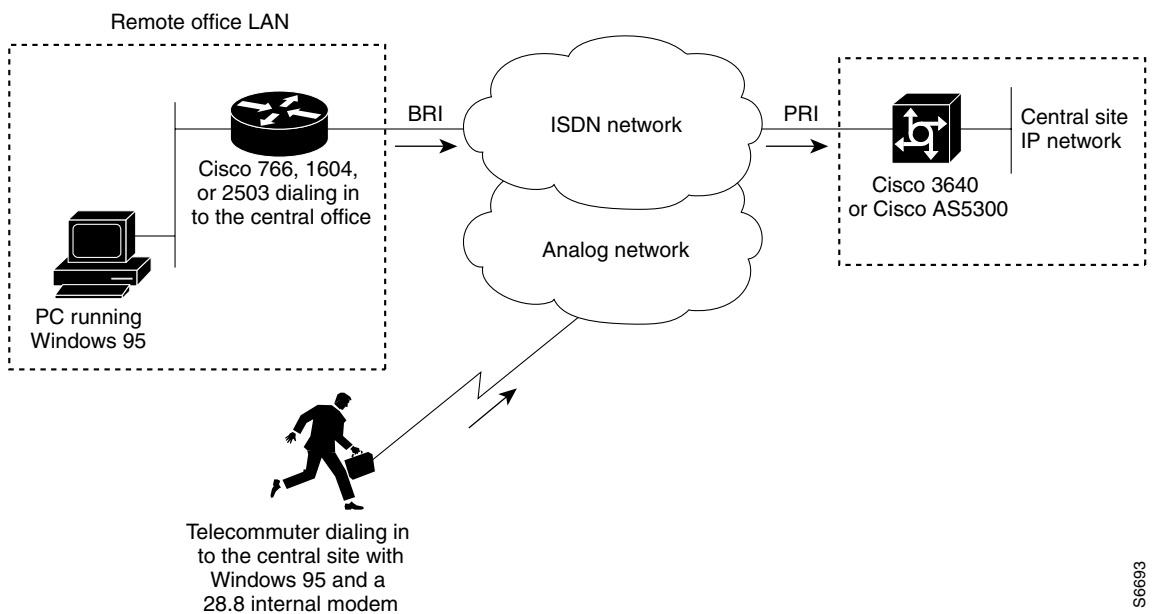

S6693

### Sample Configurations for Remote Offices and Telecommuters

The following sample configurations are provided for different combinations of dial-in scenarios, which can be derived from Figure 17 and Figure 18:

- Cisco 1604 Dialing In to a Cisco 3620 Central Site Router
- Cisco 700 Series Router Dialing In to a Cisco 3620 Central Site Access Router
- Cisco 700 Series Router Using PAT to Dial In to a Cisco AS5200 Central Site Access Server
- Cisco 1600 Using Easy IP to Dial In to a Central Site
- Cisco 3640 Central Site Configuration to Support ISDN and Modem Calls
- Cisco AS5200 Central Site Configuration Using Remote Security

---

**Note** Be sure to include your own IP addresses, host names, and security passwords where appropriate.

---

#### Cisco 1604 Dialing In to a Cisco 3620 Central Site Router

This section provides a common configuration for a Cisco 1604 remote office router dialing in to a Cisco 3620 access router positioned at a central enterprise site. Only ISDN digital calls are supported in this scenario. No analog modem calls are supported. All calls are initiated by the remote router on an as-needed basis. The Cisco 3620 is not setup to dial out to the Cisco 1604. (See Figure 17.)

The following configurations for the Cisco 1604 and Cisco 3620 use the IP unnumbered address configuration, Multilink PPP, and the dial-load threshold feature, which brings up the second B channel when the first B channel exceeds a certain limit. Because static routes are used, a routing protocol is not configured. A default static route is configured on the Cisco 1604, which points back to the central site. The central site also has a static route that points back to the remote LAN. Static route configurations assume that you have only one LAN segment at each remote office.

#### Configuration for the Remote Cisco 1604

The following example runs on the Cisco 1604 router, shown in Figure 17. This SOHO router places digital calls in to the Cisco 3620 central site access router. See the next example for the Cisco 3620 router's running configuration.

```
!  
version 11.2  
service timestamps debug datetime msec  
service timestamps log datetime msec  
service password-encryption  
no service udp-small-servers  
no service tcp-small-servers  
!  
hostname remotelan1  
!  
enable secret cisco  
!  
username NAS password dialpass  
username admin password cisco  
  
isdn switch-type basic-5ess  
!  
interface Ethernet0  
ip address 10.2.1.1 255.255.255.0
```

```

!
interface BRI0
  ip unnumbered Ethernet0
  encapsulation ppp
  dialer map ip 10.1.1.10 name NAS 5551234
  dialer load-threshold 100 either
  dialer-group 1
  no fair-queue
  ppp authentication chap pap callin
  ppp multilink
!
ip classless
ip route 0.0.0.0 0.0.0.0 10.1.1.10
ip route 10.1.1.10 255.255.255.255 BRI0
dialer-list 1 protocol ip permit
!
line con 0
line vty 0 4
  login local
!
end

```

### Configuration for the Cisco 3620 Central Site Access Router

The following sample configuration runs on the Cisco 3620 shown in Figure 17. This modular access router has one 2-port PRI network module installed in slot 1 and one 1-port Ethernet network module installed in slot 0. The router receives only digital ISDN calls from the Cisco 1604. The configuration for the Cisco 1604 is provided in the previous example.

```

!
version 11.2
service timestamps debug datetime msec
service timestamps log datetime msec
service password-encryption
no service udp-small-servers
no service tcp-small-servers
!
hostname NAS
!
aaa new-model
aaa authentication login default local
aaa authentication login console enable
aaa authentication login vty local
aaa authentication login dialin local
aaa authentication ppp default local
aaa authentication ppp dialin if-needed local
enable secret cisco
!
username admin password cisco
username remotelan1 password dialpass

async-bootp dns-server 10.1.3.1 10.1.3.2
isdn switch-type primary-5ess
!
controller T1 1/0
  framing esf
  clock source line
  linecode b8zs
  pri-group timeslots 1-24

```

## Remote Offices and Telecommuters Dialing In to a Central Site

---

```
!  
controller T1 1/1  
    framing esf  
    clock source line  
    linecode b8zs  
    pri-group timeslots 1-24  
!  
interface Loopback0  
    ip address 10.1.2.254 255.255.255.0  
!  
interface Ethernet 0/0  
    ip address 10.1.1.10 255.255.255.0  
    ip summary address eigrp 10 10.1.2.0 255.255.255.0  
!  
interface Serial 1/0:23  
    no ip address  
    encapsulation ppp  
    isdn incoming-voice modem  
    dialer rotary-group 0  
    dialer-group 1  
    no fair-queue  
    no cdp enable  
!  
interface Serial 1/1:23  
    no ip address  
    encapsulation ppp  
    isdn incoming-voice modem  
    dialer rotary-group 0  
    dialer-group 1  
    no fair-queue  
    no cdp enable  
!  
interface Dialer0  
    ip unnumbered Loopback0  
    no ip mroute-cache  
    encapsulation ppp  
    peer default ip address pool dialin_pool  
    dialer in-band  
    dialer-group 1  
    no fair-queue  
    no cdp enable  
    ppp authentication chap pap dialin  
    ppp multilink  
!  
router eigrp 10  
    network 10.0.0.0  
    passive-interface Dialer0  
    default-metric 64 100 250 100 1500  
    redistribute static  
    no auto-summary  
!  
ip local pool dialin_pool 10.1.2.1 10.1.2.50  
ip default-gateway 10.1.1.1  
  
ip route 10.2.1.1 255.255.255.255 Dialer0  
ip route 10.2.1.0 255.255.255.0 10.2.1.1  
  
ip classless  
!  
dialer-list 1 protocol ip permit  
!  
line con 0  
    login authentication console  
line aux 0  
    login authentication console
```

```

line vty 0 4
 login authentication vty
 transport input telnet rlogin
!
end

```

## Cisco 700 Series Router Dialing In to a Cisco 3620 Central Site Access Router

This section provides a common configuration for a Cisco 760 or Cisco 770 series remote office router placing digital calls in to a Cisco 3620 router positioned at a central enterprise site. All calls are initiated by the remote router on an as-needed basis. The Cisco 3620 is not set up to dial out to the remote office router. (See Figure 17.)

### Configuration for the Remote Cisco 700 Series Router

The following example is for a Cisco 760 or Cisco 770 series ISDN router placing digital calls in to a central site router that supports ISDN PRI, such as the Cisco 3620. In this scenario, ISDN unnumbered interfaces with static routes are pointing back to the Cisco 3620.

To configure the router, perform the following tasks. However, this configuration assumes you are starting from the router's default configuration. To return the router to its default configuration, issue the **set default** command.

Step	Command	Purpose
1	> > <b>set systemname remotelan1</b> remotelan1>	At the system prompt level, specify the router's host name, which is also used when responding to CHAP authentication with the Cisco 3620. For CHAP authentication, the system's name must match the username configured on the Cisco 3620.
2	remotelan1> <b>set ppp secret client</b> remotelan1> Enter new password: <b>dialpass</b> remotelan1> Enter new password: <b>dialpass</b>	Set the transmit and receive password for the client. This is the password which is used in response to CHAP authentication requests, and it must match the username password configured on the Cisco 3620.
3	remotelan1> <b>set encapsulation ppp</b>	Set PPP encapsulation for incoming and outgoing authentication instead of CPP.
4	remotelan1> <b>set ppp multilink on</b>	Enable PPP multilink.
5	remotelan1> <b>set user nas</b> remotelan1> New user nas being created	Create the profile <i>nas</i> , which is reserved for the Cisco 3620.
6	remotelan1:~> <b>set ip 0.0.0.0</b>	Specify the LAN IP address. The sequence 0.0.0.0 means that it will use the address assigned to it from the central Cisco 3620 router. See step 14.
7	remotelan1:~> <b>set ip framing none</b>	Configure the profiles to not use Ethernet framing.
8	remotelan1:~> <b>set ip route destination 0.0.0.0 gateway 10.1.1.10</b>	Set the default route to point to the Cisco 3620 router's Ethernet IP address.
9	remotelan1:~> <b>set timeout 300</b>	Set the idle time at which the B channel will be dropped. In this case, the line is dropped after 300 seconds of idle time.
10	remotelan1:~> <b>set 1/2 number 5551234</b>	Set the number to call when dialing out of the first and second B channel.
11	remotelan1:~> <b>cd lan</b>	Enter LAN profile mode.

Step	Command	Purpose
12	remotelan1:LAN> <b>set bridging off</b>	Turn bridging off.
13	remotelan1:LAN> <b>set ip routing on</b>	Turn on IP routing.
14	remotelan1:LAN> <b>set ip 10.2.1.1</b>	Set the LAN IP address for the interface.

After you configure the Cisco 760 or Cisco 770 series router, the final configuration should look like this:

```

set systemname remotelan1
set ppp secret client
set encapsulation ppp
set ppp multilink on
cd lan
set bridging off
set ip routing on
set ip 10.2.1.1
set subnet 255.255.255.0
set user nas
set bridging off
set ip 0.0.0.0
set ip netmask 0.0.0.0
set ip framing none
set ip route destination 0.0.0.0 gateway 10.1.1.10
set timeout 300
set 1 number 5551234
set 2 number 5551234
    
```

The previous software configuration does not provide for any access security. The following optional commands provide access security.

Command	Purpose
<b>set ppp authentication incoming chap</b>	Provides CHAP authentication to incoming calls.
<b>set callerid</b>	Requires the calling parties number to be matched against the configured receive numbers (such as set by the <b>set callidreceive #</b> command). This command also denies all incoming calls if no callidreceive number is configured.
<b>set remoteaccess protected</b>	Specifies a remote system password, which enables you to make changes on the Cisco 700 series router from a remote location.
<b>set localaccess protected</b>	Specifies a local system password, which enables you to make changes on the Cisco 700 series router from a local console connection.
<b>set password system</b>	Sets the system password for the above access configurations.

### Configuration for the Cisco 3620 Central Site Access Router

The following example provides a sample configuration for the Cisco 3620 router. This modular access router has one 2-port PRI network module installed in slot 1 and one 1-port Ethernet network module installed in slot 0. The router receives only digital ISDN calls over T1 lines from the Cisco 700 series remote office router, which is described in the previous example.

```
!  
version 11.2  
service timestamps debug datetime msec  
service timestamps log datetime msec  
service password-encryption  
no service udp-small-servers  
no service tcp-small-servers  
!  
hostname NAS  
!  
aaa new-model  
aaa authentication login default local  
aaa authentication login console enable  
aaa authentication login vty local  
aaa authentication login dialin local  
aaa authentication ppp default local  
aaa authentication ppp dialin if-needed local  
enable secret cisco  
!  
username admin password cisco  
username remotelan1 password dialpass  
!  
async-bootp dns-server 10.1.3.1 10.1.3.2  
isdn switch-type primary-5ess  
!  
controller T1 1/0  
    framing esf  
    clock source line  
    linecode b8zs  
    pri-group timeslots 1-24  
!  
controller T1 1/1  
    framing esf  
    clock source line  
    linecode b8zs  
    pri-group timeslots 1-24  
!  
interface Loopback0  
    ip address 10.1.2.254 255.255.255.0  
!  
interface Ethernet 0/0  
    ip address 10.1.1.10 255.255.255.0  
    ip summary address eigrp 10 10.1.2.0 255.255.255.0  
!  
interface Serial 1/0:23  
    no ip address  
    encapsulation ppp  
    isdn incoming-voice modem  
    dialer rotary-group 0  
    dialer-group 1  
    no fair-queue  
    no cdp enable  
!  
interface Serial 1/1:23  
    no ip address  
    encapsulation ppp  
    isdn incoming-voice modem  
    dialer rotary-group 0
```

```
dialer-group 1
no fair-queue
no cdp enable
!
interface Dialer0
ip unnumbered Loopback0
no ip mroute-cache
encapsulation ppp
peer default ip address pool dialin_pool
dialer in-band
dialer-group 1
no fair-queue
no cdp enable
ppp authentication chap pap dialin
ppp multilink
!
router eigrp 10
network 10.0.0.0
passive-interface Dialer0
default-metric 64 100 250 100 1500
redistribute static
no auto-summary
!
ip local pool dialin_pool 10.1.2.1 10.1.2.50
ip default-gateway 10.1.1.1

ip route 10.2.1.1 255.255.255.255 Dialer0
ip route 10.2.1.0 255.255.255.0 10.2.1.1

ip classless
!
dialer-list 1 protocol ip permit
!
line con 0
login authentication console
line aux 0
login authentication console
line vty 0 4
login authentication vty
transport input telnet rlogin
!
end
```

### Cisco 700 Series Router Using PAT to Dial In to a Cisco AS5200 Central Site Access Server

This section shows a Cisco 700 series router using the port address translation (PAT) feature to dial in to a Cisco AS5200 central site access server. IP addresses are assigned from the central site, which leverages the PAT feature to streamline multiple devices at the remote site through a single assigned address. In this example, the Cisco 700 series router has a private range of IP addresses used on the Ethernet side. However, the router is able to translate between the local private addresses and the dynamically registered address on the WAN interface. (See Figure 17.)

#### Configuration for the Cisco 700 Remote Router

The sample configuration in this section allows PCs on a LAN to boot up and acquire their IP address dynamically from a Cisco 700 series router, which in turn translates the private addresses into a single IP address assigned from a Cisco AS5200 central site router. The Cisco 700 series router also passes information via DHCP regarding the DNS server (in this example, 10.2.10.1) and the WINS server (in this example, 10.2.11.1) along with the domain name.

A possible sequence of events would be a remote PC running Windows 95 boots up on the Ethernet segment and gets its IP address and network information from the Cisco 700 series router. The PC then opens up Netscape and attempts to view a web page at the central site, which causes the Cisco 700 series router to dial in to the central site. The Cisco 700 series router dynamically obtains its address from the central site pool of addresses and uses it to translate between the private address on the local Ethernet segment and the registered IP address borrowed from the central site router.

To configure the Cisco 700 series remote router, perform the following tasks beginning in system configuration mode:

Step	Command	Purpose
1	> > <b>set systemname remotelan1</b> remotelan1>	At the system prompt level, specify the router's host name, which is also used when responding to CHAP authentication with the Cisco 3620. For CHAP authentication, the system's name must match the username configured on the Cisco 3620.
2	remotelan1> <b>set ppp secret client</b> remotelan1> Enter new password: <b>dialpass</b> remotelan1> Enter new password: <b>dialpass</b>	Set the transmit and receive password for the client. This is the password which is used in response to CHAP authentication requests, and it must match the username password configured on the Cisco 3620.
3	remotelan1> <b>set encapsulation ppp</b>	Set PPP encapsulation for incoming and outgoing authentication instead of CPP.
4	remotelan1> <b>set ppp multilink on</b>	Enable PPP multilink.
5	remotelan1> <b>set dhcp server</b>	Enable the router to act as a DHCP server and assign addresses from the private network. By default, all DHCP client addresses are assigned from the 10.0.0.0 network.
6	remotelan1> <b>set dhcp dns primary 10.2.10.1</b>	Pass the DNS server IP address to the DHCP client.
7	remotelan1> <b>set dhcp wins 10.2.11.1</b>	Pass the IP address of the WINs server to the DHCP client.
8	remotelan1> <b>set dhcp domain nas.com</b>	Set the DHCP domain name for the Cisco 3620 central site router.
9	remotelan1> <b>set user nas</b> remotelan1> New user nas being created	Create the profile <i>nas</i> , which is setup for the Cisco 3620.
10	remotelan1:nas> <b>set ip pat on</b>	Enable Port Address Translation (PAT) on the router.
11	remotelan1:nas> <b>set ip framing none</b>	Configure the profiles to not use Ethernet framing.
12	remotelan1:nas> <b>set ip route destination 0.0.0.0 gateway 10.1.1.0</b>	Set the default route to point to the Cisco 3620 router's Ethernet IP address.
13	remotelan1:nas> <b>set 1 number 5551234</b>	Set the number to call when dialing out of the first B channel.
14	remotelan1:nas> <b>set 2 number 5551234</b>	Set the number to call when dialing out of the second B channel.
15	remotelan1:nas> <b>cd lan</b>	Enter LAN profile mode.

Step	Command	Purpose
16	remotelan1:LAN> <b>set bridging off</b>	Turn bridging off.
17	remotelan1:LAN> <b>set ip routing on</b>	Turn on IP routing on.

After you configure the router, the configuration should look like this:

```
set systemname remotelan1
set encapsulation ppp
set ppp secret client
set ppp multilink on
set dhcp server
set dhcp dns primary 10.2.10.1
set dhcp wins 10.2.11.1
set dhcp domain nas.com
set user nas
set bridging off
set ip routing on
set ip framing none
set ip pat on
set ip route destination 0.0.0.0 gateway 10.1.1.0
set 1 number 5551234
set 2 number 5551234
```

### Configuration for a Cisco AS5200 Central Site Access Server

This example provides a sample configuration for a Cisco AS5200 receiving calls from the Cisco 700 series router in the previous example.

---

**Note** This configuration can also run on a Cisco 4000, 3600, or 7000 series router. However, the interface numbering scheme for these routers will be in the form of slot/port. Additionally, the clocking will be set differently. See your product's hardware and software configuration guides and configuration notes for more details.

---

```
!
version 11.2
service timestamps debug datetime msec
service timestamps log datetime msec
service password-encryption
no service udp-small-servers
no service tcp-small-servers
!
hostname NAS
!
aaa new-model
aaa authentication login default local
aaa authentication login console enable
aaa authentication login vty local
aaa authentication login dialin local
aaa authentication ppp default local
aaa authentication ppp dialin if-needed local
enable secret cisco
!
username admin password cisco
username remotelan1 password dialpass
```

```

async-bootp dns-server 10.1.3.1 10.1.3.2
isdn switch-type primary-5ess
!
controller T1 0
 framing esf
 clock source line primary
 linecode b8zs
 pri-group timeslots 1-24
!
controller T1 1
 framing esf
 clock source line secondary
 linecode b8zs
 pri-group timeslots 1-24
!
interface Loopback0
 ip address 10.1.2.254 255.255.255.0
!
interface Ethernet0
 ip address 10.1.1.10 255.255.255.0
 ip summary address eigrp 10 10.1.2.0 255.255.255.0
!
interface Serial0
 no ip address
 shutdown
!
interface Serial1
 no ip address
 shutdown
!
interface Serial0:23
 no ip address
 encapsulation ppp
 isdn incoming-voice modem
 dialer rotary-group 0
 dialer-group 1
 no fair-queue
 no cdp enable
!
interface Serial1:23
 no ip address
 encapsulation ppp
 isdn incoming-voice modem
 dialer rotary-group 0
 dialer-group 1
 no fair-queue
 no cdp enable
!
interface Dialer0
 ip unnumbered Loopback0
 no ip mroute-cache
 encapsulation ppp
 peer default ip address pool dialin_pool
 dialer in-band
 dialer-group 1
 no fair-queue
 no cdp enable
 ppp authentication chap pap dialin
 ppp multilink
!
router eigrp 10
 network 10.0.0.0
 passive-interface Dialer0
 default-metric 64 100 250 100 1500

```

## Remote Offices and Telecommuters Dialing In to a Central Site

---

```
    redistribute static
    no auto-summary
    !
ip local pool dialin_pool 10.1.2.1 10.1.2.50
ip default-gateway 10.1.1.1

ip route 10.2.1.1 255.255.255.255 Dialer0
ip route 10.2.1.0 255.255.255.0 10.2.1.1

ip classless
!
dialer-list 1 protocol ip permit
!
line con 0
    login authentication console
line aux 0
    login authentication console
line vty 0 4
    login authentication vty
    transport input telnet rlogin
!
end
```

In this configuration, the local pool is using a range of unused addresses on the same subnet that the Ethernet interface is configured on. The addresses will be used for the remote devices dialing in to the Cisco AS5200.

## Cisco 1600 Using Easy IP to Dial In to a Central Site

The following example shows the running configuration on a Cisco 1600 series router using the Easy IP (Phase 1) feature. Unlike the PAT feature for the Cisco 700 series routers, Easy IP (Phase 1) does not support DHCP server functionality. However, Easy IP (Phase 2) will support this feature. For Easy IP (Phase 1) configuration, you must statically configure the IP addresses for the hosts (PCs) on the Cisco 1600 series side of the connection. For additional information about using Easy IP, see the chapter “Configuring Easy IP” later in this document.

```
!
version 11.3
service timestamps debug datetime msec
service timestamps log datetime msec
service password-encryption
no service udp-small-servers
no service tcp-small-servers
!
hostname remotelan1
!
enable secret cisco
!
username NAS password dialpass
username admin password cisco
ip nat inside source list 1 interface BRI0 overload
!
isdn switch-type basic-5ess
!
interface Ethernet0
    ip address 13.1.1.1 255.255.255.0
    ip nat inside
!
interface BRI0
    ip address negotiated
    ip nat outside
    encapsulation ppp
```

```
dialer map ip 10.1.1.10 name NAS 5551234
dialer load-threshold 100 either
dialer-group 1
no fair-queue
ppp authentication chap pap callin
ppp multilink
!
ip classless
ip route 0.0.0.0 0.0.0.0 10.1.1.10
ip route 10.1.1.10 255.255.255.255 BRI0
access-list 1 permit 13.1.1.0 0.0.0.255
dialer-list 1 protocol ip permit
!
line con 0
line vty 0 4
  login local
!
end
```

### Cisco 3640 Central Site Configuration to Support ISDN and Modem Calls

The following configuration allows remote LANs and standalone remote users with modems to dial in to a central site. Figure 18 shows the network topology.

The Cisco 3640 has the following hardware configuration for this scenario:

- One 2-port ISDN-PRI network module installed in slot 1.
- One digital modem network module installed in slot 2 and slot 3.
- One 1-port Ethernet network module installed in slot 0.

---

**Note** Each MICA digital modem card has its own group async configuration. Additionally, a single range of async lines is used for each modem card. For additional interface numbering information, refer to the document *Digital Modem Network Module Configuration Note*.

---

```
!
version 11.2
service timestamps debug datetime msec
service timestamps log datetime msec
service password-encryption
no service udp-small-servers
no service tcp-small-servers
!
hostname NAS
!
aaa new-model
aaa authentication login default local
aaa authentication login console enable
aaa authentication login vty local
aaa authentication login dialin local
aaa authentication ppp default local
aaa authentication ppp dialin if-needed local
enable secret cisco
!
username admin password cisco
username remotelan1 password dialpass1
username remotelan2 password dialpass2
username PCuser1 password dialpass3
username PCuser2 password dialpass4
```

## Remote Offices and Telecommuters Dialing In to a Central Site

---

```
async-bootp dns-server 10.1.3.1 10.1.3.2
isdn switch-type primary-5ess
!
controller T1 1/0
 framing esf
 clock source line
 linecode b8zs
 pri-group timeslots 1-24
!
controller T1 1/1
 framing esf
 clock source line
 linecode b8zs
 pri-group timeslots 1-24
!
interface Loopback0
 ip address 10.1.2.254 255.255.255.0
!
interface Ethernet0/0
 ip address 10.1.1.10 255.255.255.0
 ip summary address eigrp 10 10.1.2.0 255.255.255.0
!
interface Serial 1/0:23
 no ip address
 encapsulation ppp
 isdn incoming-voice modem
 dialer rotary-group 0
 dialer-group 1
 no fair-queue
 no cdp enable
!
interface Serial 1/1:23
 no ip address
 encapsulation ppp
 isdn incoming-voice modem
 dialer rotary-group 0
 dialer-group 1
 no fair-queue
 no cdp enable
!
interface Group-Async1
 ip unnumbered Loopback0
 encapsulation ppp
 async mode interactive
 peer default ip address pool dialin_pool
 no cdp enable
 ppp authentication chap pap dialin
 group-range 65 88
!
interface Group-Async2
 ip unnumbered Loopback0
 encapsulation ppp
 async mode interactive
 peer default ip address pool dialin_pool
 no cdp enable
 ppp authentication chap pap dialin
 group-range 97 120
!
interface Dialer0
 ip unnumbered Loopback0
 no ip mroute-cache
 encapsulation ppp
 peer default ip address pool dialin_pool
 dialer in-band
```

```
dialer-group 1
no fair-queue
no cdp enable
ppp authentication chap pap dialin
ppp multilink
!
router eigrp 10
network 10.0.0.0
passive-interface Dialer0
no auto-summary
!
ip local pool dialin_pool 10.1.2.1 10.1.2.50
ip default-gateway 10.1.1.1
ip classless
!
dialer-list 1 protocol ip permit
!
line con 0
login authentication console
line 65 88
autoselect ppp
autoselect during-login
login authentication dialin
modem DialIn
line 97 120
autoselect ppp
autoselect during-login
login authentication dialin
modem DialIn
line aux 0
login authentication console
line vty 0 4
login authentication vty
transport input telnet rlogin
!
end
```

## Cisco AS5200 Central Site Configuration Using Remote Security

The previous examples in this section configure static CHAP authentication on the central router using the **username** command. A more common configuration to support modem and ISDN calls on a single chassis is to use the AAA security model and an external security server at the central site. Cisco recommends that you have a solid understanding of basic security principles and the AAA model before you set up this configuration. For more information about security, see the publication *Security Configuration Guide*.

## Central Site Cisco AS5200 Configuration Using TACACS+ Authentication

The following example assumes you are running TACACS+ on the remote security server.

```
!
version 11.2
service timestamps debug datetime msec
service timestamps log datetime msec
service password-encryption
no service udp-small-servers
no service tcp-small-servers
!
hostname NAS
!
aaa new-model
aaa authentication login console enable
```

## Remote Offices and Telecommuters Dialing In to a Central Site

---

```
aaa authentication login vty tacacs+
aaa authentication login dialin tacacs+
aaa authentication ppp default tacacs+
aaa authentication ppp dialin if-needed tacacs+
enable secret cisco
!
async-bootp dns-server 10.1.3.1 10.1.3.2
isdn switch-type primary-5ess
!
controller T1 0
 framing esf
 clock source line primary
 linecode b8zs
 pri-group timeslots 1-24
!
controller T1 1
 framing esf
 clock source line secondary
 linecode b8zs
 pri-group timeslots 1-24
!
interface Loopback0
 ip address 10.1.2.254 255.255.255.0
!
interface Ethernet0
 ip address 10.1.1.10 255.255.255.0
 ip summary address eigrp 10 10.1.2.0 255.255.255.0
!
interface Serial0
 no ip address
 shutdown
!
interface Serial1
 no ip address
 shutdown
!
interface Serial0:23
 no ip address
 encapsulation ppp
 isdn incoming-voice modem
 dialer rotary-group 0
 dialer-group 1
 no fair-queue
 no cdp enable
!
interface Serial1:23
 no ip address
 encapsulation ppp
 isdn incoming-voice modem
 dialer rotary-group 0
 dialer-group 1
 no fair-queue
 no cdp enable
!
interface Group-Async1
 ip unnumbered Loopback0
 encapsulation ppp
 async mode interactive
 peer default ip address pool dialin_pool
 no cdp enable
 ppp authentication chap pap dialin
 group-range 1 48
```

```

!
interface Dialer0
  ip unnumbered Loopback0
  no ip mroute-cache
  encapsulation ppp
  peer default ip address pool dialin_pool
  dialer in-band
  dialer-group 1
  no fair-queue
  no cdp enable
  ppp authentication chap pap dialin
  ppp multilink
!
router eigrp 10
  network 10.0.0.0
  passive-interface Dialer0
  redistribute static
  default-metric 64 100 250 100 1500
  no auto-summary
!
ip local pool dialin_pool 10.1.2.1 10.1.2.50
ip default-gateway 10.1.1.1
ip classless
!
dialer-list 1 protocol ip permit
!
line con 0
  login authentication console
line 1 48
  autoselect ppp
  autoselect during-login
  login authentication dialin
  modem DialIn
line aux 0
  login authentication console
line vty 0 4
  login authentication vty
  transport input telnet rlogin
!
end

```

### TACACS+ Security Server Entry

The following configuration file entry runs on the remote TACACS+ security server, which compliments the Cisco AS5200 configuration in the previous example.

```

user = remotelan1 {
    chap = cleartext "dialpass1"
    service = ppp protocol = ip {
        addr = 10.2.1.1
        route = "10.2.1.0 255.255.255.0"
    }
}

user = PCuser1 {
    login = cleartext "dialpass2"
    chap = cleartext "dialpass2"
    service = ppp protocol = ip {
        addr-pool = dialin_pool
    }
    service = exec {
        autocmd = "ppp negotiate"
    }
}

```

```

}

user = PCuser2 {
    login = cleartext "dialpass3"
    chap = cleartext "dialpass3"
    service = ppp protocol = ip {
        addr-pool = dialin_pool
    }
    service = exec {
        autocmd = "ppp negotiate"
    }
}

```

## Bidirectional Dial Networking between a Central Site and Remote Offices or Telecommuters

Sometimes a headquarter's gateway access server is required to dial out to a remote site while receiving incoming calls. This type of networking need is designed around a specific business support model, such as shown in Figure 19.

Figure 19 Headquarters Configured for Dial-In and Dial-Out Networking

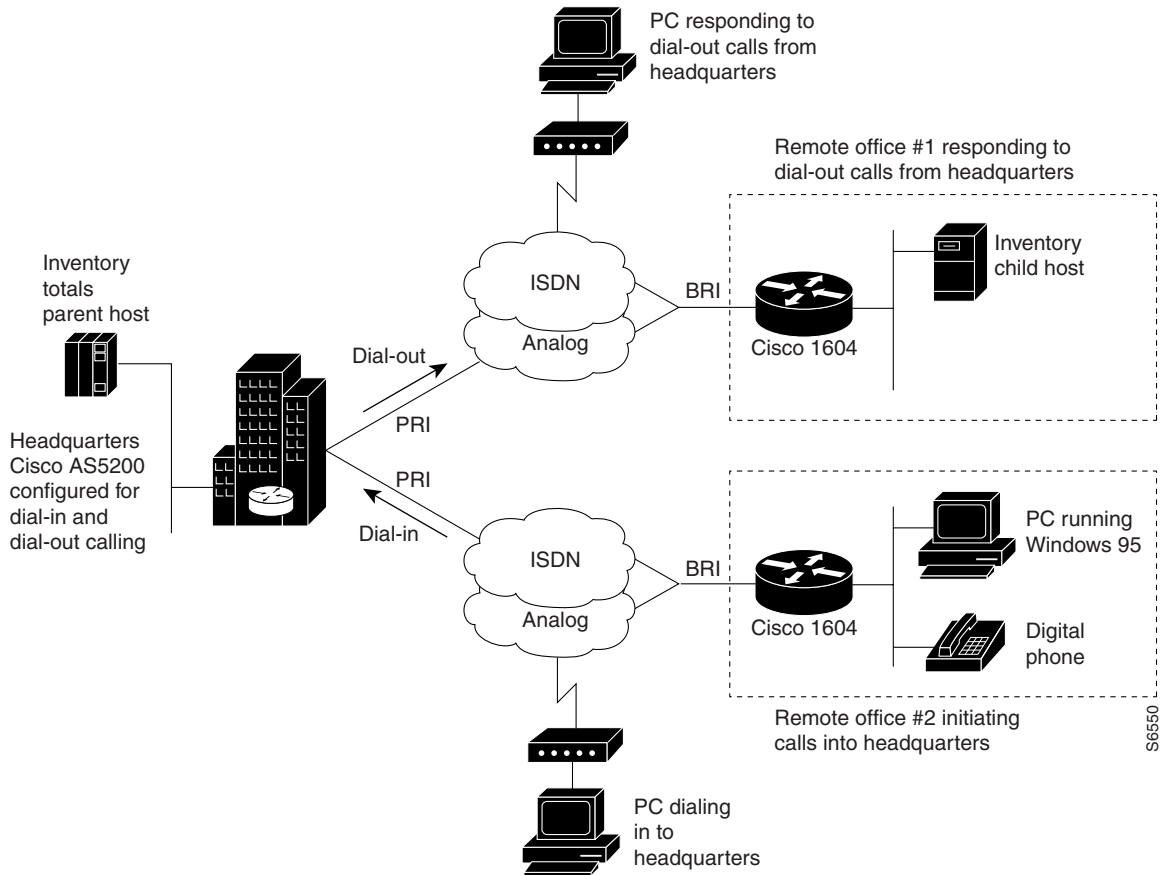

Figure 19 shows a typical dial-in and dial-out network scenario, which amounts to only 25% of all dial topologies. The headquarters' Cisco AS5200 initiates a connection with a Cisco 1604 at remote office 1. After a connection is established, the remote site's file server (shown as *Inventory child host*) runs a batch processing application with the headquarters' mainframe (shown as *Inventory totals parent host*). While files are being transferred between remote office 1 and headquarters, remote office 2 is successfully dialing in to headquarters.

There are some restrictions for dial out calling. Dial out analog and digital calls are commonly made to remote ISDN routers, such as the Cisco 1604. On the whole, dial out calls are not made from a central site router to a remote PC but rather from a remote PC in to the central site. However, central site post offices often call remote office routers on demand to deliver e-mail. Callback is enabled on dial-in scenarios only. The majority of a dial out software configuration is setup on the headquarters' router not the remote office router. Dialing out to a stack group of multiple chassis is not supported by Cisco IOS software. Note that Multichassis Multilink PPP and virtual private dial networks (VPDNs) are dial-in only solutions.

## Dialer Profiles and Virtual Profiles

You can set up profiles in your dial solution to discriminate access on a user-specific basis. For example, if the chief network administrator is dialing into the enterprise, a unique user profile can be created with an idle timeout of one year, and universal access privileges setup to all networks in the company. For less fortunate users, access can be restricted to an idle timeout of 10 seconds and network connections setup for only a few addresses.

Depending on the size and scope of your dial solution, you can setup two different types of profiles: dialer profiles or virtual profiles. Dialer profiles are individual user profiles setup on routers or access servers in a small scale-dial solution. This type of profile is configured locally on the router and is limited by the number of interfaces that exist on the router. When an incoming call comes into the dial pool, the dialer interface binds the caller to a dialer profile via the caller ID or the caller name.

Figure 20 shows an example of how dialer profiles can be used:

- You need to bridge over multiple ISDN channels.
- You want to use ISDN to back-up a WAN link, but still have the ISDN interface available during those times that the WAN link is up.
- A security server, such as a AAA TACACS or RADIUS server, is not available for use.

---

**Note** For more information about dialer profiles, see the chapters “Configuring Peer-to-Peer DDR with Dialer Profiles” and “Configuring Dial Backup with Dialer Profiles” later in this document.

---

**Figure 20 Dial-In Scenario for Dialer Profiles**

Virtual profiles are user-specific profiles for large scale dial solutions; however, these profiles are not manually configured on each router or access server. A virtual profile is a unique Point-to-Point Protocol (PPP) application that can create and configure a virtual access interface dynamically when a dial-in call is received, and tear down the interface dynamically when the call ends.

The configuration information for a virtual profile's virtual access interface can come from a virtual template interface, or from user-specific configuration stored on an AAA server, or both. The virtual profile user-specific configuration stored on the AAA server is identified by the authentication name for the call-in user. (That is, if the AAA server authenticates the user as samson, the user-specific configuration is listed under samson in the AAA users file.) The virtual profile user-specific configuration should include only the configuration that is not shared by multiple users. Shared configuration should be placed in the virtual template interface where it can be cloned on many virtual access interfaces as needed.

AAA configurations are much easier to manage for large numbers of dial-in users. Virtual profiles can span across a group of access servers, but a AAA server is required. Virtual profiles are setup independently of which access server, interface, or port number users connect to. For users that share duplicate configuration information, it is best to enclose the configuration in a virtual template. This eliminates the duplication of commands in each of the user records on the AAA server.

The user-specific AAA configuration used by virtual profiles is interface configuration information and downloaded during LCP negotiations. Another feature, called Per-User Configuration, also uses configuration information gained from a AAA server. However, Per-User Configuration uses *network* configuration (such as access lists and route filters) downloaded during NCP negotiations.

Figure 21 shows an example of how virtual profiles are used:

- A large dial-in solution is available, which includes many access servers or routers (for example, three or more devices stacked together in a multichassis multilink PPP scenario).
- Discrimination between large numbers of users is needed.
- Setup and maintenance of a user profile for each dial-in user on each access server or router is much too time consuming.
- A security server, such as a AAA TACACS or RADIUS server, is available for use.

**Note** For a virtual profile configuration example, see the section “Large Scale Dial-In Configuration Using Virtual Profiles.” For more information about virtual profiles, refer to the chapters “Configuring Virtual Profiles” and “Per-User Configuration” later in this document.

**Figure 21 Dial-In Scenario for Virtual Profiles**

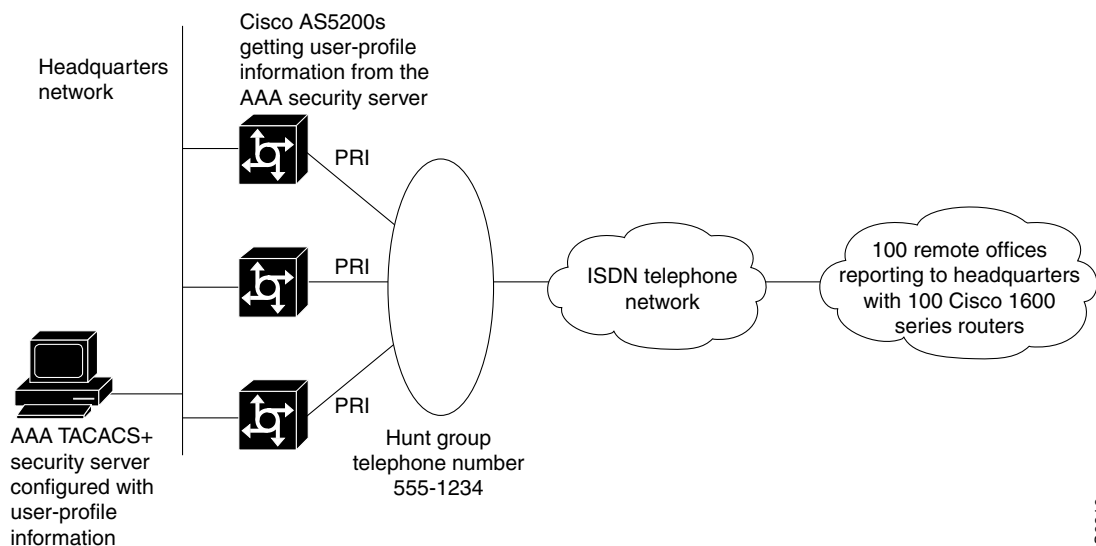

56816

## Configuration Examples

In most cases, dialer profiles are configured on access servers or routers that receive calls and must discriminate between users, such as many different remote routers dialing in. See Figure 22.

**Figure 22 Remote Cisco 1600s Dialing In to a Cisco AS5200 at the Central Site**

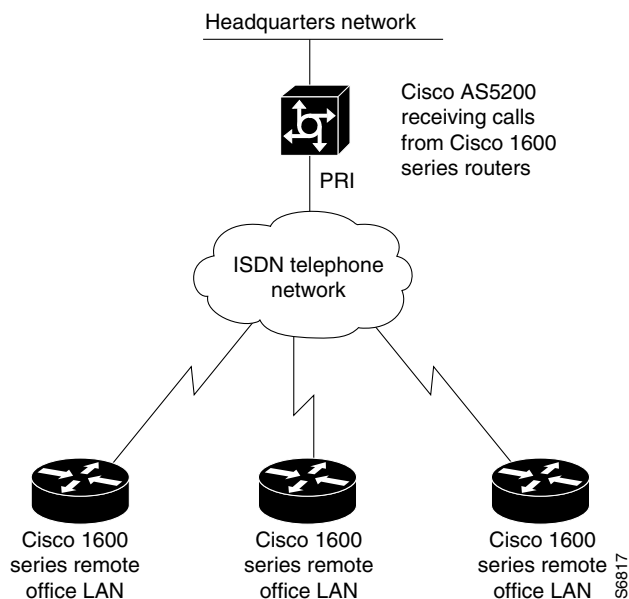

Access servers or routers that only place calls (not receive calls) do not need any awareness of dialer profiles configured. Remote routers do not need to discriminate based on which device they are calling into. For example, if multiple Cisco 1600 series routers are dialing into one Cisco AS5200, the Cisco 1600s should not be configured with dialer profiles. The Cisco AS5200 should be configured with dialer profiles. Do not configure dialer profiles on devices that *only* make calls.

The following sample configurations are provided for different types of dial scenarios, which can be derived from Figure 19 through Figure 22:

- Examples with dialer profiles
  - Cisco AS5200 Configuration with Dialer Profiles
  - Cisco 1604 ISDN Configuration with Dialer Profiles
  - Cisco 1604 Async Configuration with Dialer Profiles
- Examples without dialer profiles
  - Cisco AS5200 Configuration without Dialer Profiles
  - Cisco 1604 ISDN Configuration without Dialer Profiles
  - Cisco 1604 Async Configuration without Dialer Profiles
- Large Scale Dial-In Configuration Using Virtual Profiles

---

**Note** Be sure to include your own IP addresses, host names, and security passwords where appropriate.

---

## Cisco AS5200 Configuration with Dialer Profiles

The following bidirectional dial configuration runs on the headquarters' Cisco AS5200 in Figure 19. This configuration enables calls to be sent to the SOHO router and received from remote hosts and clients. The calling is bidirectional.

```

!
version 11.2
service udp-small-servers
service tcp-small-servers
!
hostname 5200
!
aaa new-model
aaa authentication login default local
aaa authentication login console enable
aaa authentication login vty local
aaa authentication login dialin local
aaa authentication ppp default local
aaa authentication ppp dialin if-needed local
enable secret cisco
!
username async1 password cisco
username async2 password cisco
username async3 password cisco
username async4 password cisco
username async5 password cisco
username async6 password cisco
username async7 password cisco
username async8 password cisco
username isdn1 password cisco
username isdn2 password cisco
username isdn3 password cisco
username isdn4 password cisco
username isdn5 password cisco
username isdn6 password cisco
username isdn7 password cisco
username isdn8 password cisco
username DialupAdmin password cisco
!
isdn switch-type primary-dms100
chat-script cisco-default ABORT ERROR "" "AT" OK "ATDT\T" TIMEOUT 60 CONNECT
!
controller T1 0
framing esf
clock source line primary
linecode b8zs
pri-group timeslots 1-24
!
controller T1 1
framing esf
clock source line secondary
linecode b8zs
pri-group timeslots 1-24
!
interface loopback 1
ip address 131.108.38.40 255.255.255.128
!
interface loopback 2
ip address 131.108.38.130 255.255.255.128
!
interface Ethernet0
ip address 131.108.39.40 255.255.255.0
no ip mroute-cache
ip ospf priority 0

```

```
!  
interface Serial0:23  
  no ip address  
  no ip mroute-cache  
  encapsulation ppp  
  isdn incoming-voice modem  
  dialer pool-member 2  
!  
interface Serial1:23  
  no ip address  
  no ip mroute-cache  
  encapsulation ppp  
  isdn incoming-voice modem  
  dialer pool-member 2  
!  
interface Group-Async1  
  no ip address  
  no ip mroute-cache  
  encapsulation ppp  
  async mode interactive  
  dialer in-band  
  dialer pool-member 1  
  ppp authentication chap pap  
  group-range 1 48  
!  
interface Dialer10  
  ip unnumbered loopback 1  
  encapsulation ppp  
  peer default ip address dialin_pool  
  dialer remote-name async1  
  dialer string 14085268983  
  dialer hold-queue 10  
  dialer pool 1  
  dialer-group 1  
  ppp authentication pap chap callin  
  ppp pap sent-username DialupAdmin password 7 07063D11542  
!  
interface Dialer11  
  ip unnumbered loopback 1  
  encapsulation ppp  
  no peer default ip address pool  
  dialer remote-name async2  
  dialer string 14085262012  
  dialer hold-queue 10  
  dialer pool 1  
  dialer-group 1  
  ppp authentication pap chap callin  
  ppp pap sent-username DialupAdmin password 7 07063D11542  
!  
interface Dialer12  
  ip unnumbered loopback 1  
  encapsulation ppp  
  no peer default ip address pool  
  dialer remote-name async3  
  dialer string 14085260706  
  dialer hold-queue 10  
  dialer pool 1  
  dialer-group 1  
  ppp authentication pap chap callin  
  ppp pap sent-username DialupAdmin password 7 07063D11542  
!  
interface Dialer13  
  ip unnumbered loopback 1  
  encapsulation ppp  
  no peer default ip address pool
```

```
dialer remote-name async4
dialer string 14085262731
dialer hold-queue 10
dialer pool 1
dialer-group 1
ppp authentication pap chap callin
ppp pap sent-username DialupAdmin password 7 07063D11542
!
interface Dialer14
ip unnumbered loopback 1
encapsulation ppp
no peer default ip address pool
dialer remote-name async5
dialer string 14085264431
dialer hold-queue 10
dialer pool 1
dialer-group 1
ppp authentication pap chap callin
ppp pap sent-username DialupAdmin password 7 07063D11542
!
interface Dialer15
ip unnumbered loopback 1
encapsulation ppp
no peer default ip address pool
dialer remote-name async6
dialer string 14085261933
dialer hold-queue 10
dialer pool 1
dialer-group 1
ppp authentication pap chap callin
ppp pap sent-username DialupAdmin password 7 07063D11542
!
interface Dialer16
ip unnumbered loopback 1
encapsulation ppp
no peer default ip address pool
dialer remote-name async7
dialer string 14085267631
dialer hold-queue 10
dialer pool 1
dialer-group 1
ppp authentication pap chap callin
ppp pap sent-username DialupAdmin password 7 07063D11542
!
interface Dialer17
ip unnumbered loopback 2
encapsulation ppp
no peer default ip address pool
dialer remote-name async8
dialer string 14085265153
dialer hold-queue 10
dialer pool 2
dialer-group 1
ppp authentication chap pap
!
interface Dialer18
ip unnumbered loopback 2
encapsulation ppp
no peer default ip address pool
dialer remote-name isdn1
dialer string 14085267887
dialer hold-queue 10
dialer pool 2
dialer-group 1
ppp authentication chap pap
```

```
!  
interface Dialer19  
  ip unnumbered loopback 2  
  encapsulation ppp  
  no peer default ip address pool  
  dialer remote-name isdn2  
  dialer string 14085261591  
  dialer hold-queue 10  
  dialer pool 2  
  dialer-group 1  
  ppp authentication chap pap  
!  
interface Dialer20  
  ip unnumbered loopback 2  
  encapsulation ppp  
  no peer default ip address pool  
  dialer remote-name isdn3  
  dialer string 14085262118  
  dialer hold-queue 10  
  dialer pool 2  
  dialer-group 1  
  ppp authentication chap pap  
!  
interface Dialer21  
  ip unnumbered loopback 2  
  encapsulation ppp  
  no peer default ip address pool  
  dialer remote-name isdn4  
  dialer string 14085263757  
  dialer hold-queue 10  
  dialer pool 2  
  dialer-group 1  
  ppp authentication chap pap  
!  
interface Dialer22  
  ip unnumbered loopback 2  
  encapsulation ppp  
  no peer default ip address pool  
  dialer remote-name isdn5  
  dialer string 14085263769  
  dialer hold-queue 10  
  dialer pool 2  
  dialer-group 1  
  ppp authentication chap pap  
!  
interface Dialer23  
  ip unnumbered loopback 2  
  encapsulation ppp  
  no peer default ip address pool  
  dialer remote-name isdn6  
  dialer string 14085267884  
  dialer hold-queue 10  
  dialer pool 2  
  dialer-group 1  
  ppp authentication chap pap  
!  
interface Dialer24  
  ip unnumbered loopback 2  
  encapsulation ppp  
  no peer default ip address pool  
  dialer remote-name isdn7  
  dialer string 14085267360  
  dialer hold-queue 10  
  dialer pool 2
```

```
dialer-group 1
  ppp authentication chap pap
!
interface Dialer25
  ip unnumbered loopback 2
  encapsulation ppp
  no peer default ip address pool
  dialer remote-name isdn8
  dialer string 14085260361
  dialer hold-queue 10
  dialer pool 2
  dialer-group 1
  ppp authentication chap pap
!
router ospf 1
  redistribute static subnets
  passive-interface Dialer1
  passive-interface Dialer2
  network 131.108.0.0 0.0.255.255 area 0
!
ip local pool dialin_pool 10.1.2.1 10.1.2.50
ip domain-name cisco.com
ip classless
!
dialer-list 1 protocol ip permit
!
line con 0
  exec-timeout 0 0
line 1 24
  no exec
  exec-timeout 0 0
  autoselect during-login
  autoselect ppp
  script dialer cisco-default
  login local
  modem InOut
  modem autoconfigure type microcom_hdms
  transport input telnet
line aux 0
line vty 0 1
  exec-timeout 60 0
  password cisco
  login
line vty 2 5
  exec-timeout 5 0
  password cisco
  login
!
end
```

### Cisco 1604 ISDN Configuration with Dialer Profiles

The following configuration runs on the remote office Cisco 1604 router, which receives calls from the Cisco AS5200 central site access server. See Figure 19.

```
!
version 11.2
service udp-small-servers
service tcp-small-servers
!
hostname isdn1
!
enable password cisco
```

```
!
username 5200 password cisco
username isdn1 password cisco
isdn switch-type basic-5ess
!
interface Ethernet0
 ip address 131.108.40.1 255.255.255.0
!
interface BRI0
 no ip address
 encapsulation ppp
 dialer pool-member 1
 ppp authentication chap pap
!
interface Dialer1
 ip address 131.108.38.131 255.255.255.128
 encapsulation ppp
 no peer default ip address pool
 dialer remote-name 5200
 dialer string 14085269328
 dialer hold-queue 10
 dialer pool 2
 dialer-group 1
 ppp authentication chap pap
!
ip classless
ip route 0.0.0.0 0.0.0.0 131.108.38.130
dialer-list 1 protocol ip permit
!
line con 0
line vty 0 4
 password cisco
 login
 password cisco
 login
!
end
```

### Cisco 1604 Async Configuration with Dialer Profiles

The following asynchronous configuration runs on the remote office Cisco 1604 router, which receives calls from the Cisco AS5200 central site access server. See Figure 19.

```
!
version 11.2
service udp-small-servers
service tcp-small-servers
!
hostname async1
!
enable password cisco
!
username 5200 password cisco
username async1 password cisco
chat script dial_out "" "ATDT\T" timeout 60 connect \c
!
interface Ethernet0
 ip address 131.108.41.1 255.255.255.0
!
interface serial 0
 physical-layer async
 no ip address
 encapsulation ppp
 dialer pool-member 1
```

```
    ppp authentication chap pap
!
interface Dialer10
  ip address 131.108.38.41 255.255.255.128
  encapsulation ppp
  no peer default ip address pool
  dialer remote-name 5200
  dialer string 14085269328
  dialer hold-queue 10
  dialer pool 1
  dialer-group 1
  ppp authentication chap pap
!
ip classless
ip route 0.0.0.0 0.0.0.0 131.108.38.40
dialer-list 1 protocol ip permit
!
line con 0
line 1
  password cisco
  login
  script modem dial_out
!
end
```

### Cisco AS5200 Configuration without Dialer Profiles

The following bidirectional dial configuration runs on the headquarters' Cisco AS5200 in Figure 19. This configuration enables calls to be sent to the SOHO router and received from remote hosts and clients. The calling is bidirectional.

```
!
version 11.2
service udp-small-servers
service tcp-small-servers
!
hostname 5200
!
aaa new-model
aaa authentication login default local
aaa authentication login console enable
aaa authentication login vty local
aaa authentication login dialin local
aaa authentication ppp default local
aaa authentication ppp dialin if-needed local
enable secret cisco
!
username async1 password cisco
username async2 password cisco
username async3 password cisco
username async4 password cisco
username async5 password cisco
username async6 password cisco
username async7 password cisco
username async8 password cisco
username isdn1 password cisco
username isdn2 password cisco
username isdn3 password cisco
username isdn4 password cisco
username isdn5 password cisco
username isdn6 password cisco
username isdn7 password cisco
username isdn8 password cisco
```

## Bidirectional Dial Networking between a Central Site and Remote Offices or Telecommuters

---

```
username DialupAdmin password cisco
!
isdn switch-type primary-dms100
chat-script cisco-default ABORT ERROR "" "AT" OK "ATDT\T" TIMEOUT 60 CONNECT
!
controller T1 0
 framing esf
 clock source line primary
 linecode b8zs
 pri-group timeslots 1-24
 description ISDN Controller 0
!
controller T1 1
 framing esf
 clock source line secondary
 linecode b8zs
 pri-group timeslots 1-24
 description ISDN Controller 1
!
interface Ethernet0
 ip address 131.108.39.40 255.255.255.0
 no ip mroute-cache
 ip ospf priority 0
!
interface Serial0:23
 no ip address
 no ip mroute-cache
 encapsulation ppp
 isdn incoming-voice modem
 dialer rotary-group 2
!
interface Serial1:23
 no ip address
 no ip mroute-cache
 encapsulation ppp
 isdn incoming-voice modem
 dialer rotary-group 2
!
interface Group-Async1
 no ip address
 no ip mroute-cache
 encapsulation ppp
 async dynamic address
 async mode interactive
 dialer in-band
 dialer rotary-group 1
 ppp authentication pap callin
 ppp pap sent-username HQ5200 password 7 09434678520A
 group-range 1 24
!
interface Dialer1
 ip address 131.108.38.40 255.255.255.128
 encapsulation ppp
 no peer default ip address pool
 dialer in-band
 dialer map ip 131.108.38.41 name async1 14085268983
 dialer map ip 131.108.38.42 name async2 14085262012
 dialer map ip 131.108.38.43 name async3 14085260706
 dialer map ip 131.108.38.44 name async4 14085262731
 dialer map ip 131.108.38.45 name async5 14085264431
```

```
dialer map ip 131.108.38.46 name async6 14085261933
dialer map ip 131.108.38.47 name async7 14085267631
dialer map ip 131.108.38.48 name async8 14085265153
dialer hold-queue 10
dialer-group 1
ppp authentication pap chap callin
ppp pap sent-username DialupAdmin password 7 07063D11542
!
interface Dialer2
ip address 131.108.38.130 255.255.255.128
encapsulation ppp
no peer default ip address pool
dialer in-band
dialer map ip 131.108.38.131 name isdn1 14085267887
dialer map ip 131.108.38.132 name isdn2 14085261591
dialer map ip 131.108.38.133 name isdn3 14085262118
dialer map ip 131.108.38.134 name isdn4 14085263757
dialer map ip 131.108.38.135 name isdn5 14085263769
dialer map ip 131.108.38.136 name isdn6 14085267884
dialer map ip 131.108.38.137 name isdn7 14085267360
dialer map ip 131.108.38.138 name isdn8 14085260361
dialer hold-queue 10
dialer-group 1
ppp authentication chap pap
ppp multilink
!
router ospf 1
redistribute static subnets
passive-interface Dialer1
passive-interface Dialer2
network 131.108.0.0 0.0.255.255 area 0
!
ip domain-name cisco.com
ip classless
!
dialer-list 1 protocol ip permit
!
line con 0
exec-timeout 0 0
line 1 24
no exec
exec-timeout 0 0
autoselect during-login
autoselect ppp
script dialer cisco-default
login local
modem InOut
modem autoconfigure type microcom_hdms
transport input telnet
line aux 0
line vty 0 1
exec-timeout 60 0
password cisco
login
line vty 2 5
exec-timeout 5 0
password cisco
login
!
end
```

### Cisco 1604 ISDN Configuration without Dialer Profiles

The following configuration runs on the remote office Cisco 1604 router, which dials into the headquarters' Cisco AS5200. This configuration does not receive calls from the Cisco AS5200. See Figure 19.

```
!  
version 11.1  
service udp-small-servers  
service tcp-small-servers  
!  
hostname isdn1  
!  
enable password cisco  
!  
username 5200 password cisco  
username isdn1 password cisco  
isdn switch-type basic-5ess  
!  
interface Ethernet0  
 ip address 131.108.40.1 255.255.255.0  
!  
interface BRI0  
 ip address 131.108.38.131 255.255.255.128  
 encapsulation ppp  
 dialer map ip 131.108.38.130 name 5200 14085269328  
 dialer-group 1  
 ppp authentication chap pap  
!  
ip classless  
ip route 0.0.0.0 0.0.0.0 131.108.38.130  
dialer-list 1 protocol ip permit  
!  
line con 0  
line vty 0 4  
 password cisco  
 login  
 password cisco  
 login  
!  
end
```

### Cisco 1604 Async Configuration without Dialer Profiles

The following asynchronous configuration runs on the remote office Cisco 1604 router, which dials into the headquarters' Cisco AS5200. This configuration does not receive calls from the Cisco AS5200. See Figure 19.

```
!  
version 11.2  
service udp-small-servers  
service tcp-small-servers  
!  
hostname async1  
!  
enable password cisco  
!  
username 5200 password cisco  
username async1 password cisco  
chat script dial_out "" "ATDT\T" timeout 60 connect \c
```

```
!  
interface Ethernet0  
  ip address 131.108.41.1 255.255.255.0  
!  
interface serial 0  
  physical-layer async  
  ip address 131.108.38.41 255.255.255.128  
  encapsulation ppp  
  dialer in-band  
  dialer map ip 131.108.38.40 name 5200 modem-script dial_out 14085269328  
  dialer-group 1  
  ppp authentication chap pap  
!  
ip classless  
ip route 0.0.0.0 0.0.0.0 131.108.38.40  
dialer-list 1 protocol ip permit  
!  
line con 0  
line 1  
  password cisco  
  login  
  password cisco  
  login  
!  
end
```

### Large Scale Dial-In Configuration Using Virtual Profiles

The following example configuration is used on each central site stack member shown in Figure 21. This configuration is for a large scale dial-in scenario.

```
!  
aaa new-model  
aaa authentication login default none  
aaa authentication ppp default radius  
aaa authentication ppp admin local  
aaa authorization network radius  
isdn switch-type primary-5ess  
!  
interface Serial0:23  
  no ip address  
  no ip mroute-cache  
  no cdp enable  
  ppp authentication chap  
!  
tacacs-server host 171.68.203.45  
virtual-profile aaa
```

The following is a sample configuration entry running on a RADIUS security server, which is queried by each central site stack member when a call comes in. This entry includes the virtual profile configuration information for remote users dialing into the central site stack solution.

In this example, virtual profiles are configured by both virtual templates and AAA configuration. John and Rick can dial in from anywhere and have their same keepalive settings and their own IP addresses.

The remaining AV-pair settings are not used by virtual profiles. They are the network-protocol access lists and route filters used by AAA-based Per-User Configuration.

In the AAA configuration cisco-avpair lines, "\n" is used to indicate the start of a new Cisco IOS command line.

```
john Password = "welcome"
    User-Service-Type = Framed-User,
    Framed-Protocol = PPP,
    cisco-avpair = "lcp:interface-config=keepalive 75\nip address 100.100.100.100
255.255.255.0",
    cisco-avpair = "ip:rte-fltr-out#0=router igrp 60",
    cisco-avpair = "ip:rte-fltr-out#3=deny 171.0.0.0 0.255.255.255",
    cisco-avpair = "ip:rte-fltr-out#4=deny 172.0.0.0 0.255.255.255",
    cisco-avpair = "ip:rte-fltr-out#5=permit any"
rick Password = "emoclew"
    User-Service-Type = Framed-User,
    Framed-Protocol = PPP,
    cisco-avpair = "lcp:interface-config=keepalive 100\nip address 200.200.200.200
255.255.255.0",
    cisco-avpair = "ip:inacl#3=permit ip any any precedence immediate",
    cisco-avpair = "ip:inacl#4=deny igrp 0.0.1.2 255.255.0.0 any",
    cisco-avpair = "ip:outacl#2=permit ip any any precedence immediate",
    cisco-avpair = "ip:outacl#3=deny igrp 0.0.9.10 255.255.0.0 any"
```

## Telecommuters Dialing In to a Mixed Protocol Environment

This scenario describes how to provide remote access to employees dialing in to a mixed protocol enterprise network. The sample configurations provided in this section assume that enterprise telecommuters are dialing in with modems or terminal adapters from outside the headquarters' LAN.

The following sections are provided:

- Description of a Mixed Protocol Enterprise Environment
- Sample Enterprise Network for Dial-In Access
- Mixed Protocol Configuration Examples

### Description of a Mixed Protocol Enterprise Environment

Sometimes an enterprise conducts its daily business operations across internal mixed protocol environments. (See Figure 23 and Table 2.) For example, an enterprise might deploy an IP base across the entire intranet while still allowing file sharing with other protocols such as AppleTalk and AppleTalk Remote Access (ARA).

Figure 23 Large Enterprise with a Multiprotocol Network

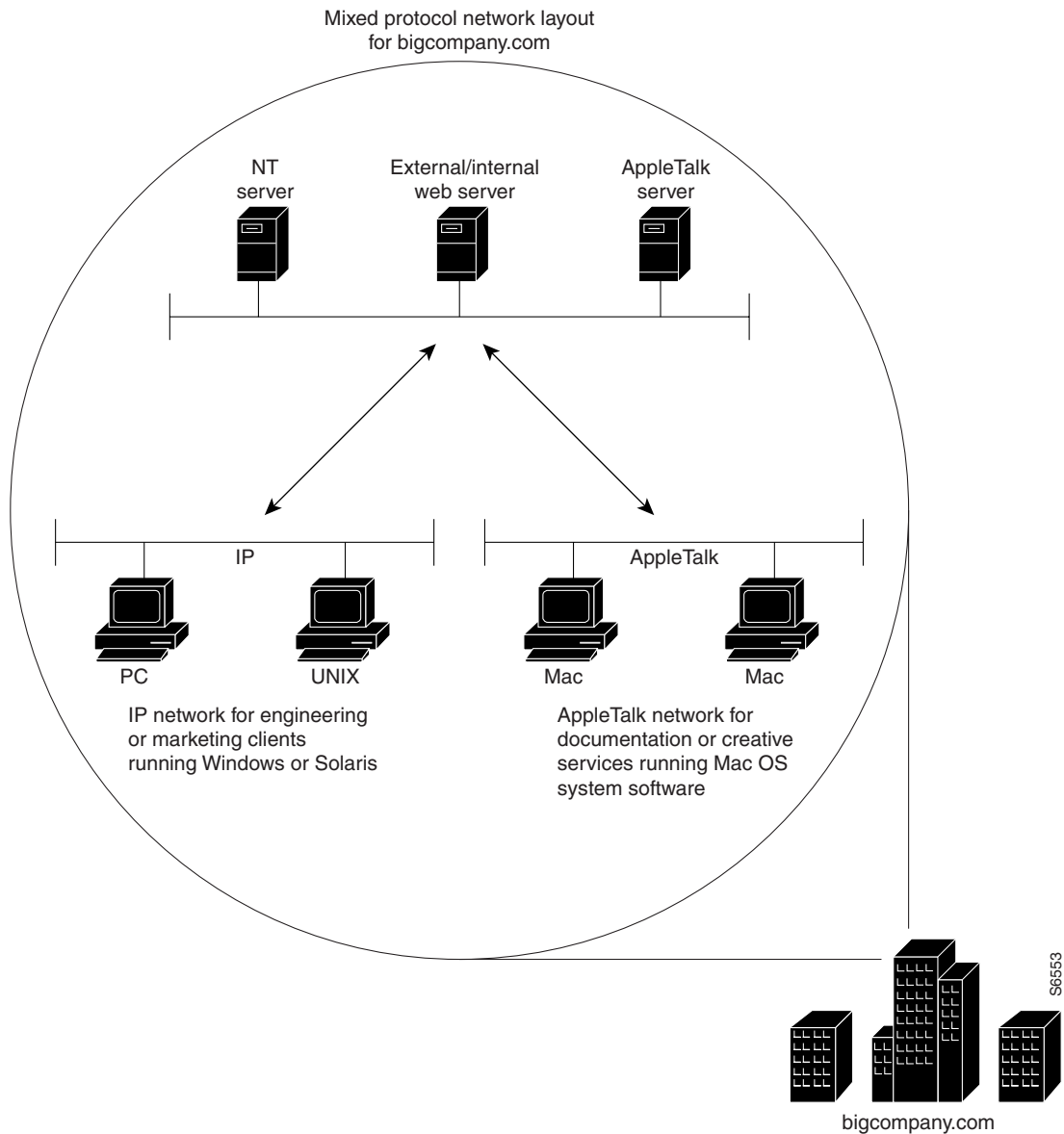

Table 2 Typical Mixed Protocol Environment

Applications Running on the Network Server	Remote or Local Client Applications	Protocol Used to Support the Network	Internal Supporting Department
Windows NT	Windows 95 or Windows 3.1 running on PCs	IP	Marketing, human resources, engineering, customer support
UNIX	SunOS or Solaris running on a UNIX based workstation or NCD	IP	Engineering and customer support
AppleTalk	Mac OS System Software 7.5 running on Macintosh computers	AppleTalk	Documentation and creative services

**Table 2 Typical Mixed Protocol Environment (Continued)**

Applications Running on the Network Server	Remote or Local Client Applications	Protocol Used to Support the Network	Internal Supporting Department
NetWare	Novell NetWare client software	IPX	Marketing, human resources, engineering, customer support

### Sample Enterprise Network for Dial-In Access

Figure 24 shows a sample enterprise network, which supports 10,000 registered token card holders. Some registered users might use their access privileges each day, while others might use their access privileges very infrequently, such as only on business trips. The dial-in access provisioned for outsiders, such as partners or vendors, is supported separately in a firewalled setup.

Five Cisco AS5200s are positioned to provide 250 dial-in ports for incoming modem calls. A Catalyst 1900 is used as a standalone switch to provide Ethernet switching between the Cisco AS5200s and the 100BaseT interfaces on the backbone routers. Two Cisco 7200 series routers are used to reduce the processing workload on the access servers and provide access to the company’s backbone. If the Cisco 7200 series devices were not used in the network solution, the Cisco AS5200s could not update routing tables, especially if 20 to 30 additional routers existed on the company’s backbone. Two additional backbone switches are used to provide access to the company network.

**Note** Depending on your networking needs, the Cisco 7200 series could be substituted by one or more Cisco 4500s, 4700s, or 3640s. Additionally, the Cisco AS5200s could be replaced by Cisco 3640s loaded with MICA digital modem cards.

**Figure 24 Sample Enterprise Network Topology**

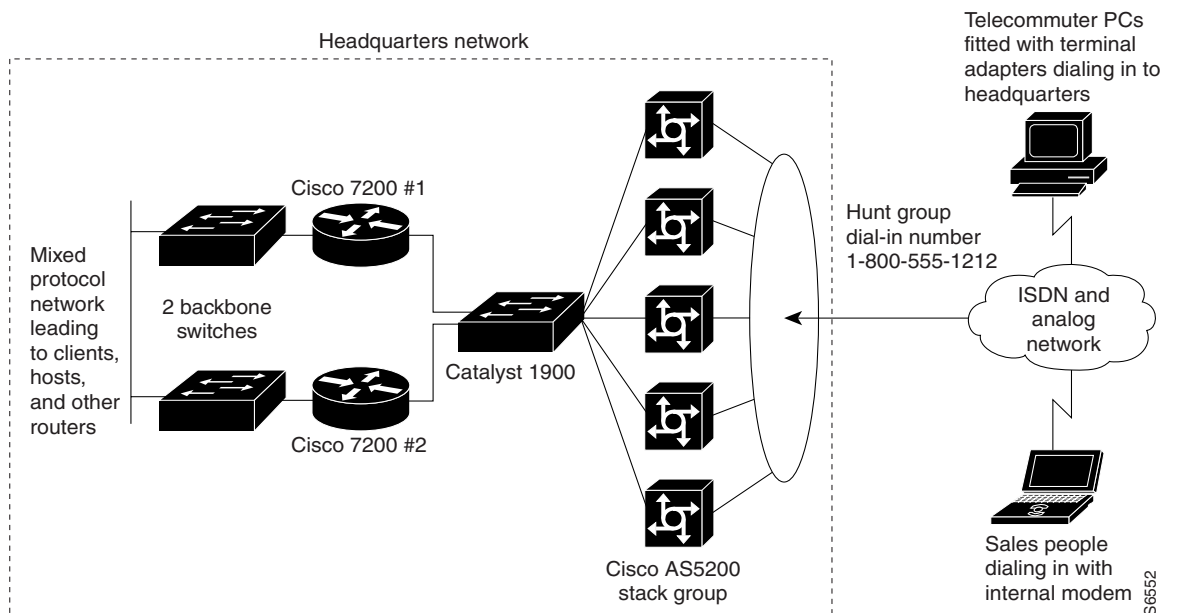

If you are setting up dial-in access for remote terminal adapters, the settings configured on the terminal adapters must match the setting on the access server or router. Depending on your business application, terminal adapters can operate in many different modes. (See Table 3.)

**Table 3 Options for Terminal Adapter Settings**

Terminal Adapter Mode	Comments
Synchronous PPP	Cisco recommends you use this mode for most terminal adapter scenarios. By default, Cisco access servers and routers have synchronous PPP enabled. Therefore, additional configuration is required on the router or access server.
V.120	Use this mode for asynchronous to synchronous communication, which can be used to tunnel character mode sessions over synchronous ISDN. Cisco recommends you use this mode with mid-range routers, such as the Cisco 4500.
V.110	Use this modem for setting up cellular modem access.

## Mixed Protocol Configuration Examples

These sample configurations are intended to run on each network device featured in Figure 24, which allows remote users to dial in to a mixed protocol environment.

- Cisco 7200 #1 Backbone Router
- Cisco 7200 #2 Backbone Router
- Cisco AS5200 Universal Access Server

---

**Note** Be sure to include your own IP addresses, host names, and security passwords where appropriate.

---

### Cisco 7200 #1 Backbone Router

The following configuration runs on the router labeled Cisco 7200 #1 in Figure 24. The Fast Ethernet interface 0/0 connects to the corporate backbone switch. The Fast Ethernet interface 1/0 connects to the Catalyst 1900 switch, which in turn connects to the Cisco AS5200 access servers.

```

!
version 11.2
no service udp-small-servers
no service tcp-small-servers
!
hostname bbone-dial1
!
aaa new-model
aaa authentication login default local
aaa authentication login console enable
!
username admin password cisco
!
boot system flash slot0:
enable secret <password>
appletalk routing
ipx routing
!

```

```
interface FastEthernet0/0
 ip address 10.0.1.52 255.255.255.192
 appletalk cable-range 1000-1000
 appletalk zone Networking Infrastructure
 ipx network 1000
!
interface FastEthernet1/0
 ip address 10.1.1.2 255.255.255.224
 no ip redirects
 appletalk cable-range 7650-7650 7650.1
 appletalk zone Dial-Up Net
 ipx network 7650
!
 standby ip 10.1.1.1
 standby priority 101
 standby preempt
!
router eigrp 109
 redistribute static
 network 10.0.0.0
 no auto-summary
!
ip classless
ip http server
no logging console
!
ip route 10.1.2.0 255.255.255.192 10.1.1.10
!
line con 0
 login authentication console
!
line vty 0 4
 login authentication default
!
end
```

### Cisco 7200 #2 Backbone Router

The following configuration runs on the router labeled Cisco 7200 #2 in Figure 24. The Fast Ethernet interface 0/0 connects to the corporate backbone switch. The Fast Ethernet interface 1/0 connects to the Catalyst 1900 switch, which in turn connects to the Cisco AS5200 access servers.

```
!
version 11.2
no service udp-small-servers
no service tcp-small-servers
!
hostname bbone-dial2
!
aaa new-model
aaa authentication login default local
aaa authentication login console enable
!
username admin password cisco
!
boot system flash slot0:
enable secret <password>
appletalk routing
ipx routing
!
interface FastEthernet0/0
 ip address 10.0.1.116 255.255.255.192
 appletalk cable-range 1001-1001
```

```

appletalk zone Networking Infrastructure
ipx network 1001
!
interface FastEthernet1/0
ip address 10.1.1.3 255.255.255.224
no ip redirects
appletalk cable-range 7650-7650 7650.2
appletalk zone Dial-Up Net
ipx network 7650
!
standby ip 10.1.1.1
!
router eigrp 109
 redistribute static
 network 10.0.0.0
 no auto-summary
!
ip classless
ip http server
no logging console
!
ip route 10.1.2.0 255.255.255.192 10.1.1.10
!
line con 0
login authentication console
!
line vty 0 4
 login authentication console
!
end

```

## Cisco AS5200 Universal Access Server

The following sample configuration runs on each Cisco AS5200 in the stackgroup shown in Figure 24:

```

!
version 11.2
service timestamps debug datetime msec
service timestamps log datetime msec
service password-encryption
no service udp-small-servers
no service tcp-small-servers
!
appletalk routing
ipx routing
appletalk virtual net 7651 Dial-Up Net
arap network 7652 Dial-Up Net
!
hostname NAS
!
aaa new-model
aaa authentication login default local
aaa authentication login console enable
aaa authentication login vty local
aaa authentication login dialin local
aaa authentication ppp default local
aaa authentication ppp dialin if-needed local
aaa authentication arap default auth-guest local
enable secret cisco
!
username admin password cisco
username puser1 password mypass
isdn switch-type primary-5ess

```

```
!  
controller T1 0  
    framing esf  
    clock source line primary  
    linecode b8zs  
    pri-group timeslots 1-24  
!  
controller T1 1  
    framing esf  
    clock source line secondary  
    linecode b8zs  
    pri-group timeslots 1-24  
!  
interface loopback 0  
    ip address 10.1.2.0 255.255.255.192  
    ipx network 7651  
!  
interface Ethernet0  
    ip address 10.1.1.10 255.255.255.0  
    appletalk cable-range 7650  
    appletalk zone Dial-Up-Net  
    ipx network 7650  
!  
interface Serial0  
    no ip address  
    shutdown  
!  
interface Serial1  
    no ip address  
    shutdown  
!  
interface Serial0:23  
    no ip address  
    encapsulation ppp  
    isdn incoming-voice modem  
    dialer rotary-group 0  
    dialer-group 1  
    no fair-queue  
    no cdp enable  
!  
interface Serial1:23  
    no ip address  
    encapsulation ppp  
    isdn incoming-voice modem  
    dialer rotary-group 0  
    dialer-group 1  
    no fair-queue  
    no cdp enable  
!  
interface Group-Async1  
    ip unnumbered Ethernet0  
    encapsulation ppp  
    async mode interactive  
    peer default ip address pool dialin_pool  
    appletalk client-mode  
    ipx ppp-client  
    no cdp enable  
    ppp authentication chap pap dialin  
    group-range 1 48  
!  
interface Dialer0  
    ip unnumbered Ethernet0  
    no ip mroute-cache  
    encapsulation ppp  
    peer default ip address pool dialin_pool
```

```
ipx ppp-client
appletalk client-mode
dialer in-band
dialer-group 1
no fair-queue
no cdp enable
ppp authentication chap pap dialin
ppp multilink
!
ip local pool dialin_pool 10.1.2.1 10.1.2.62
ip default-gateway 10.1.1.1
ip classless
ip route 0.0.0.0 0.0.0.0 10.1.1.1
!
dialer-list 1 protocol ip permit
!
async-bootp dns-server 10.1.0.40 10.1.0.170
async-bootp nbns-server 10.0.235.228 10.0.235.229
!
xremote buffersize 72000
xremote tftp host 10.0.2.74
!
line con 0
 login authentication console
line 1 48
 autoselect ppp
 autoselect during-login
 autoselect arap
 arap enable
 arap authentication default
 arap timelimit 240
 arap warningtime 15
 login authentication dialin
 modem DialIn
 terminal-type dialup
line aux 0
 login authentication console
line vty 0 4
 login authentication vty
 transport input telnet rlogin
!
end
```

