

# Configuring NCIA Client/Server Topologies

This chapter describes native client interface architecture (NCIA) support for Systems Network Architecture (SNA) devices. NCIA Server and the NCIA client/server model extends the scalability of NCIA I, the earlier NCIA implementation, by minimizing the number of central-site RSRB or DLSw+ peer connections required to support a large number of NCIA clients. For a complete description of the commands mentioned in this chapter, refer to the “NCIA Server Configuration Commands” chapter of the *Bridging and IBM Networking Command Reference*.

Cisco’s NCIA server feature implements RFC 2114, Data Link Switch Client Access Protocol.

## NCIA Server Session to Local Token Ring Using DLSw+ Local Switch

The network configuration shown in Figure 115 includes NCIA clients that connect to a front-end processor (FEP) on a Token Ring through a local router (the NCIA server). The virtual ring is used in conjunction with DLSw+ local switch. The routing information field (RIF) of each circuit is terminated on the virtual ring. Figure 116 shows a logical view of an NCIA server session using a DLSw+ local switch (connected to a local Token Ring). In addition to Token Ring, an NCIA server also supports Ethernet, SDLC, and QLLC network connections as well as Channel Interface Processor (CIP) connections through a DLSw+ local switch. For more information on the different media types that a DLSw+ local switch supports, refer to the “Configuring DLSw+” chapter.

Figure 115 NCIA Server Session to Local Token Ring Using DLSw+ Local Switch

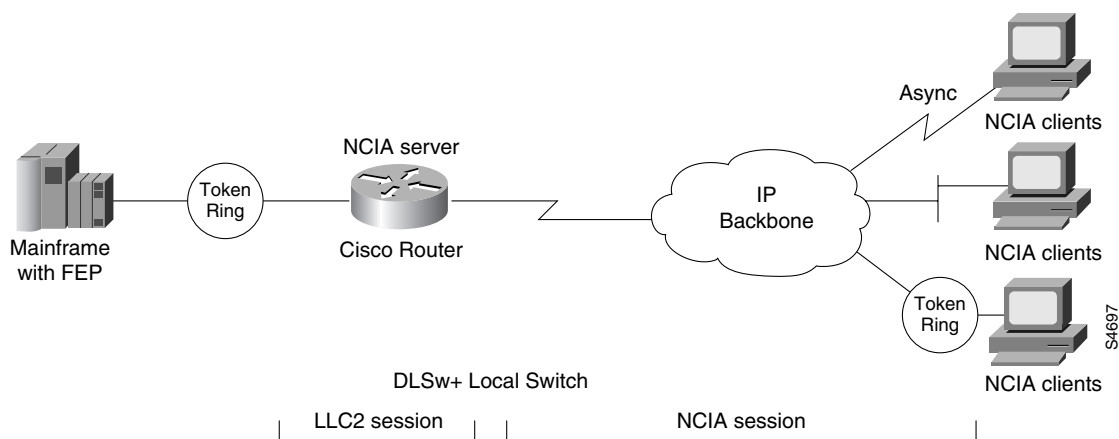

**Figure 116 Logical View of NCIA Server Session to a Local Token Ring Using DLSw+ Local Switch**

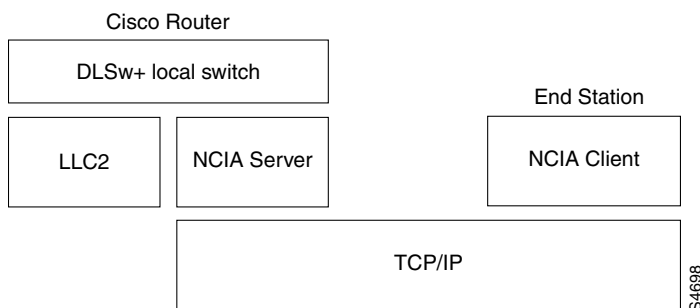

### Configuration Task List

To configure an NCIA session connected to a local Token Ring, perform the tasks in the following sections.

- Define a Source-Bridge Ring Group for DLSw+
- Define a DLSw+ Local Peer for the Router
- Configure an NCIA Server on the Router

For a configuration example, see “NCIA Server Session to Local Token Ring Using DLSw+ Local Switch Example” at the end of this chapter.

### Define a Source-Bridge Ring Group for DLSw+

In DLSw+, the source-bridge ring group specifies the virtual ring that will appear to be the last ring in the RIF. This ring is transparent to the NCIA client. From the host’s point of view, all NCIA clients look like stations sitting on the virtual ring. To define a source-bridge ring group for DLSw+, perform the following task in global configuration mode:

Task	Command
Define a ring group.	<b>source-bridge ring-group</b> <i>ring-group</i> [ <i>virtual-mac-address</i> ] <sup>1</sup>

1. This command is documented in the “Source-Route Bridging Commands” chapter of the *Bridging and IBM Networking Command Reference*.

### Define a DLSw+ Local Peer for the Router

Defining a DLSw+ local peer for a router enables DLSw+ local switch. You specify all local DLSw+ parameters as part of the local peer definition. To define a local peer, perform the following task in global configuration mode:

Task	Command
Define the DLSw+ local peer.	<b>dlsw local-peer</b> [ <i>peer-id ip-address</i> ] [ <b>group</b> <i>group</i> ] [ <b>border</b> ] [ <b>cost</b> <i>cost</i> ] [ <b>If</b> <i>size</i> ] [ <b>keepalive</b> <i>seconds</i> ] [ <b>passive</b> ] [ <b>promiscuous</b> ] [ <b>biu-segment</b> ] <sup>1</sup>

1. This command is documented in the “DLSw+ Configuration Commands” chapter of the *Bridging and IBM Networking Command Reference*.

## Configure an NCIA Server on the Router

Configuring an NCIA server on a router enables the router to perform two roles:

- Establish TCP/NDLC sessions with clients for the purpose of sending and receiving data.
- Use the standard interface (CLSI) to communicate with other software modules in the router, such as APPN, DLSw+, and DSPU, and act as the data intermediary between them and the clients of the NCIA server.

To configure an NCIA server, perform the following task in global configuration mode:

Task	Command
Configure the NCIA server.	<code>ncia server server-number server-ip-address server-virtual-mac-address virtual-mac-address virtual-mac-range [inbound-only] [keepalive seconds] [tcp_keepalive minutes]</code>

## NCIA Server Session with DLSw+

In the network configuration shown in Figure 117, the NCIA server uses DLSw+ to connect its clients to the FEP through a remote router. Figure 118 shows a logical view of the NCIA Server session with DLSw+.

Figure 117 NCIA Server Session with DLSw+

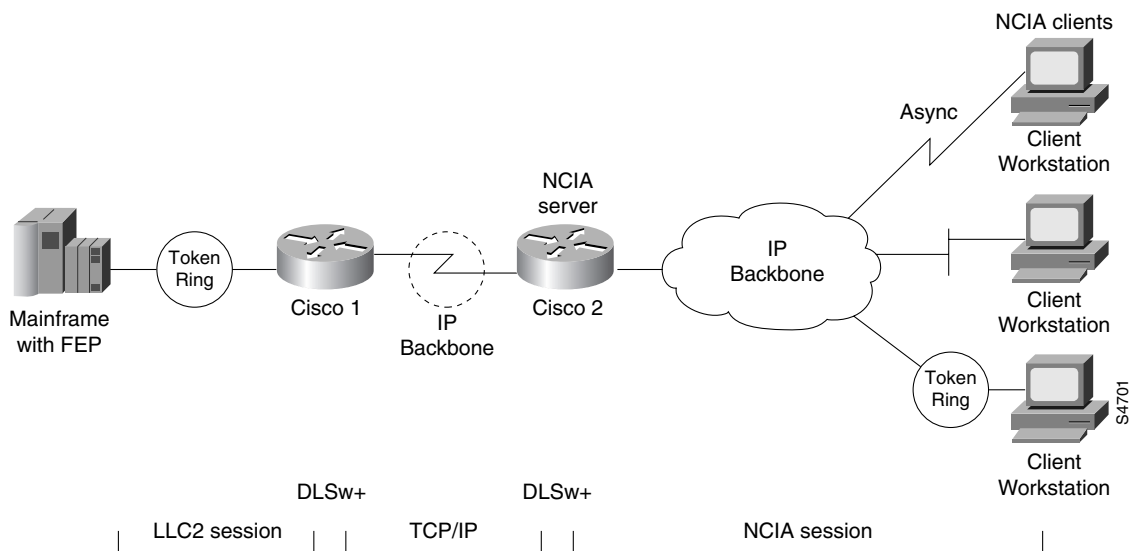

**Figure 118 Logical View of NCIA Server with DLSw+**

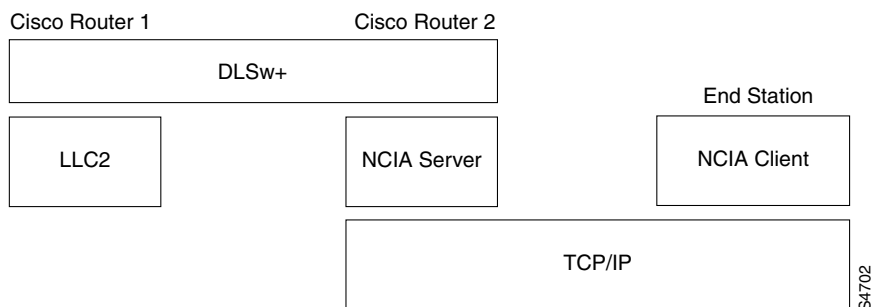

## Configuration Task List

To configure an NCIA Server session connected to a remote router using DLSw+, perform the tasks in the following sections.

- Define a Source-Bridge Ring Group for DLSw+
- Define a DLSw+ Local Peer for the Router
- Define a DLSw+ Remote Peer
- Configure an NCIA Server on the Local Router

For a configuration example, see “NCIA Server Session with DLSw+ Example” at the end of this chapter.

## Define a Source-Bridge Ring Group for DLSw+

The source-bridge ring can be shared between DLSw+ and SRB/RSRB. In DLSw+, the source-bridge ring group specifies the virtual ring that will appear to be the last ring in the RIF. Because RIFs are terminated at the router, there is no correlation between the ring-group number specified in DLSw+ peers. The numbers can be the same for management simplicity, but they do not have to be. To define a source-bridge ring group for DLSw+, perform the following task in global configuration mode:

Task	Command
Define a ring group.	<b>source-bridge ring-group</b> <i>ring-group</i> [ <i>virtual-mac-address</i> ] <sup>1</sup>

1. This command is documented in the “Source-Route Bridging Commands” chapter of the *Bridging and IBM Networking Command Reference*.

## Define a DLSw+ Local Peer for the Router

Defining a DLSw+ local peer for a router enables DLSw+. You specify all local DLSw+ parameters as part of the local peer definition. To define a local peer, perform the following task in global configuration mode:

Task	Command
Define the DLSw+ local peer.	<b>dlsw local-peer</b> [ <i>peer-id ip-address</i> ] [ <i>group group</i> ] [ <i>border</i> ] [ <i>cost cost</i> ] [ <i>if size</i> ] [ <i>keepalive seconds</i> ] [ <i>passive</i> ] [ <i>promiscuous</i> ] [ <i>biu-segment</i> ]

## Define a DLSw+ Remote Peer

To configure TCP encapsulation on a remote peer, perform the following task in global configuration mode:

Task	Command
Define a TCP encapsulation remote peer.	<b>dlsw remote-peer</b> <i>list-number</i> <b>tcp</b> <i>ip-address</i> [ <b>backup-peer</b> <i>ip-address</i> ] [ <b>bytes-netbios-out</b> <i>bytes-list-name</i> ] [ <b>cost</b> <i>cost</i> ] [ <b>dest-mac</b> <i>mac-address</i> ] [ <b>dmac-output-list</b> <i>access-list-number</i> ] [ <b>dynamic</b> ] [ <b>host-netbios-out</b> <i>host-list-name</i> ] [ <b>inactivity</b> <i>minutes</i> ] [ <b>keepalive</b> <i>seconds</i> ] [ <b>if</b> <i>size</i> ] [ <b>linger</b> <i>minutes</i> ] [ <b>lsap-output-list</b> <i>list</i> ] [ <b>no-llc</b> <i>minutes</i> ] [ <b>priority</b> ] [ <b>tcp-queue-max</b> <i>size</i> ] [ <b>timeout</b> <i>seconds</i> ]

## Configure an NCIA Server on the Local Router

Configuring an NCIA server on the local router enables the router to perform two roles:

- Establish TCP/NDLC sessions with clients to send and receive data.
- Use the standard interface (CLSI) to communicate with other software modules in the router, such as APPN, DLSw+, and DSPU, and act as the data intermediary between them and the NCIA clients.

To configure an NCIA server, perform the following task in global configuration mode:

Task	Command
Configure the NCIA server.	<b>ncia server</b> <i>server-number</i> <i>server-ip-address</i> <i>server-virtual-mac-address</i> <i>virtual-mac-address</i> <i>virtual-mac-range</i> [ <b>inbound-only</b> ] [ <b>keepalive</b> <i>seconds</i> ] [ <b>tcp_keepalive</b> <i>minutes</i> ]

## NCIA Server Session with DSPU

In the network configuration shown in Figure 119, the NCIA server uses DSPU to connect its clients to the FEP through a remote router. Figure 120 shows a logical view of the NCIA Server session with RSRB/DLSw+ and DSPU.

Figure 119 NCIA Server Session with DSPU

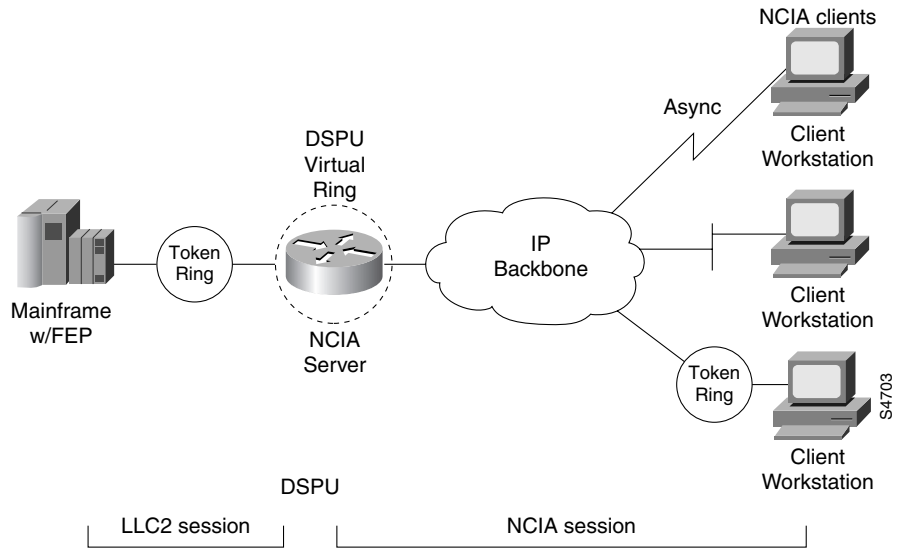
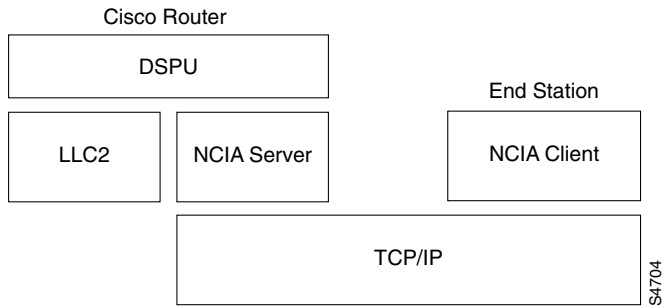

Figure 120 Logical View of NCIA Server with DSPU



### Configuration Task List

To configure an NCIA Server session connected to a remote router using DSPU, perform the tasks in the following sections.

- Define DSPU Upstream Host
- Explicitly Define Downstream PU
- Define Dedicated LU
- Configure the NCIA Server as the Underlying Transport Mechanism

For a configuration example, see “NCIA Server Session with DSPU Example” at the end of this chapter.

## Define DSPU Upstream Host

To define a DSPU host over Token Ring, Ethernet, FDDI, remote source-route bridging (RSRB), or virtual data link control (VDLC) connections, perform the following task in global configuration mode:

Task	Command
Define a DSPU host over Token Ring, Ethernet, FDDI, RSRB, or virtual data link control connections.	<b>dspu host</b> <i>host-name</i> <b>xid-snd</b> <i>xid</i> <b>rmac</b> <i>remote-mac</i> [ <b>rsap</b> <i>remote-sap</i> ] [ <b>lsap</b> <i>local-sap</i> ] [ <b>interface</b> <i>slot/port</i> ] [ <b>window</b> <i>window-size</i> ] [ <b>maxiframe</b> <i>max-iframe</i> ] [ <b>retries</b> <i>retry-count</i> ] [ <b>retry-timeout</b> <i>retry-timeout</i> ] [ <b>focalpoint</b> ]

## Explicitly Define Downstream PU

To explicitly define a downstream PU over Token Ring, Ethernet, FDDI, RSRB, virtual data link control, or NCIA connections, perform the following task in global configuration mode:

Task	Command
Explicitly define a downstream PU over Token Ring, Ethernet, FDDI, RSRB, virtual data link control, or NCIA connections.	<b>dspu pu</b> <i>pu-name</i> [ <b>rmac</b> <i>remote-mac</i> ] [ <b>rsap</b> <i>remote-sap</i> ] [ <b>lsap</b> <i>local-sap</i> ] [ <b>xid-rcv</b> <i>xid</i> ] [ <b>interface</b> <i>slot/port</i> ] [ <b>window</b> <i>window-size</i> ] [ <b>maxiframe</b> <i>max-iframe</i> ] [ <b>retries</b> <i>retry-count</i> ] [ <b>retry-timeout</b> <i>retry-timeout</i> ]

## Define Dedicated LU

To define a dedicated LU or a range of dedicated LUs for an upstream host and downstream PU, perform the following task in global configuration mode:

Task	Command
Define a dedicated LU or a range of dedicated LUs for a downstream PU.	<b>dspu lu</b> <i>lu-start</i> [ <i>lu-end</i> ] { <b>host</b> <i>host-name</i> <i>host-lu-start</i>   <b>pool</b> <i>pool-name</i> } [ <b>pu</b> <i>pu-name</i> ]

## Configure the NCIA Server as the Underlying Transport Mechanism

To configure the NCIA server as the underlying transport mechanism, perform the following task in global configuration mode:

Task	Command
Configure the NCIA server as the underlying transport mechanism.	<b>dspu ncia</b> [ <i>server-number</i> ]

To enable a local SAP on the NCIA server for use by downstream PUs, perform the following task in global configuration mode:

Task	Command
Enable local SAP for downstream PUs.	<b>dspu ncia enable-pu</b> [ <b>lsap</b> <i>local-sap</i> ]

## NCIA Server Session with RSRB

The network configuration shown in Figure 121 includes NCIA clients that connect to a FEP on a Token Ring through a remote router. Figure 122 shows a logical view of the NCIA Server session with RSRB (to a remote Token Ring). Because DLSw+ is the latest technology provided by Cisco, Cisco does not encourage using the NCIA Server feature with RSRB. If the router on the host side is running DLSw+, RSRB should not be used. Support for the NCIA Server feature with RSRB is provided to encourage RSRB users to migrate to DLSw+.

Figure 121 NCIA Server Session with RSRB

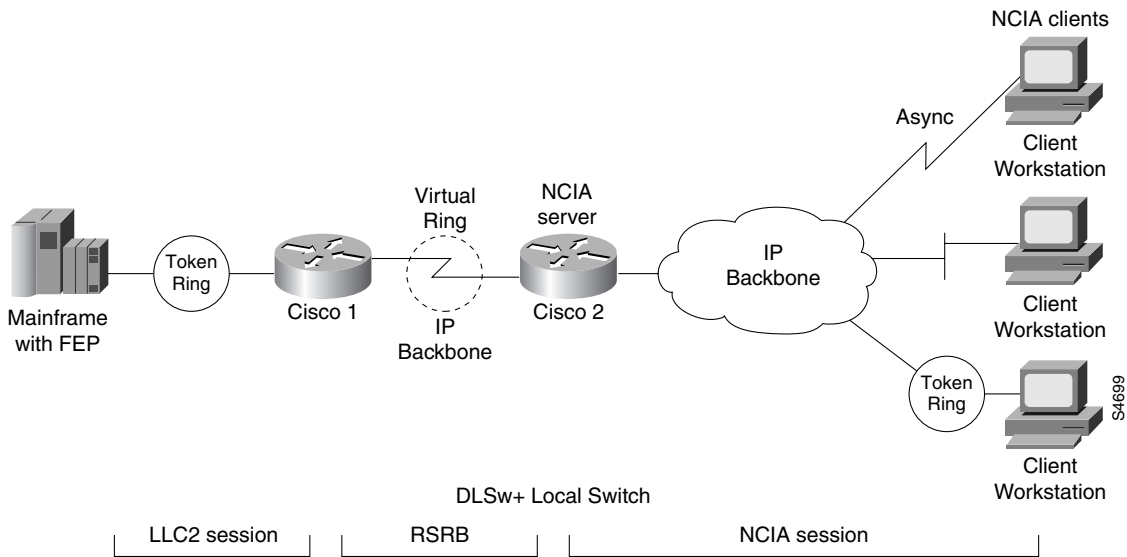
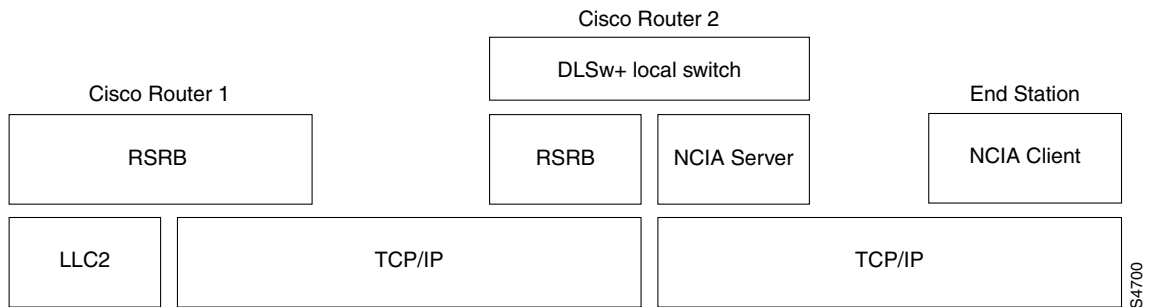

Figure 122 Logical View of NCIA Server Session with RSRB (Remote Token Ring)



### Configuration Task List

To configure an NCIA Server session connected to a remote Token Ring using RSRB, perform the tasks in the following sections.

- Define a Source-Bridge Ring Group for DLSw+ and RSRB
- Identify the Remote Peer (TCP Connection)
- Define a DLSw+ Local Peer for the Local Router

- Configure an NCIA Server on the Router
- Configure an RSRB Ring for the NCIA Server on the Local Router

For a configuration example, see “NCIA Server Session with DLSw+ Example” at the end of this chapter.

## Define a Source-Bridge Ring Group for DLSw+ and RSRB

The source-bridge virtual ring can be shared between DLSw+ and SRB/RSRB. In DLSw+, the source-bridge ring group specifies the virtual ring that will appear to be the last ring in the RIF. Because RIFs are terminated at the router, the ring group numbers specified in commands to set up DLSw+ peers can be different. The ring group numbers can be the same for management simplicity, but they do not have to be.

To define a source-bridge ring group for DLSw+, perform the following task in global configuration mode:

Task	Command
Define a ring group.	<b>source-bridge ring-group</b> <i>ring-group</i> [ <i>virtual-mac-address</i> ] <sup>1</sup>

1. This command is documented in the “Source-Route Bridging Commands” chapter of the *Bridging and IBM Networking Command Reference*.

## Identify the Remote Peer (TCP Connection)

In our implementation, whenever you connect Token Rings using non-Token Ring media, you must treat that non-Token Ring media as a virtual ring by assigning it to a ring group. Every router with which you want to exchange Token Ring traffic must be a member of this same ring group. For more information about defining a ring group, see the “Define a Ring Group in SRB Context” section of the “Configuring Source-Route Bridging” chapter of this document.

To identify the remote peers, perform the following task in global configuration mode:

Task	Command
Identify the IP address of a peer in the ring group with which to exchange source-bridge traffic using TCP.	<b>source-bridge remote-peer</b> <i>ring-group</i> <b>tcp</b> <i>ip-address</i> [ <b>if</b> <i>size</i> ] [ <b>tcp-receive-window</b> <i>wsz</i> ] [ <b>local-ack</b> ] [ <b>priority</b> ]

Specify one **source-bridge remote-peer** command for each peer router that is part of the virtual ring. Also specify one **source-bridge remote-peer** command to identify the IP address of the local router.

NCIA Server supports only RSRB pass-through mode. Local acknowledgment is not supported.

## Define a DLSw+ Local Peer for the Local Router

Defining a DLSw+ local peer for the local router enables DLSw+. You specify all local DLSw+ parameters as part of the local peer definition. To define a local peer, perform the following task in global configuration mode:

Task	Command
Define the DLSw+ local peer.	<b>dls</b> <b>local-peer</b> [ <b>peer-id</b> <i>ip-address</i> ] [ <b>group</b> <i>group</i> ] [ <b>border</b> ] [ <b>cost</b> <i>cost</i> ] [ <b>if</b> <i>size</i> ] [ <b>keepalive</b> <i>seconds</i> ] [ <b>passive</b> ] [ <b>promiscuous</b> ] [ <b>biu-segment</b> ]

## Configure an NCIA Server on the Router

Configuring an NCIA server on a router enables the router to perform two roles:

- Establish TCP/NDLC sessions with clients for the purpose of sending and receiving data.
- Use the standard interface (CLSI) to communicate with other software modules in the router, such as APPN, DLSw+, and DSPU, and to act as the data intermediary between them and the NCIA clients.

To configure an NCIA server, perform the following task in global configuration mode:

Task	Command
Configure the NCIA server.	<b>ncia server</b> <i>server-number server-ip-address server-virtual-mac-address virtual-mac-address virtual-mac-range [inbound-only] [keepalive seconds] [tcp_keepalive minutes]</i>

## Configure an RSRB Ring for the NCIA Server on the Local Router

Configuring an RSRB ring to associate with the NCIA server on the local router provides the virtual ring that connects the DLSw ring within the local router and the target ring between the local router and the remote router.

To configure an RSRB ring for the NCIA server on the local router, perform the following task in global configuration mode:

Task	Command
Define the NCIA/RSRB interface.	<b>ncia rsrb</b> <i>virtual-ring local-bridge local-ring ncia-bridge ncia-ring virtual-mac-address</i>

## Monitor and Maintain an NCIA Server Network

You can monitor and maintain the operation of an NCIA Server network. To display information about the state of the NCIA Server feature and perform maintenance tasks, perform the following tasks in EXEC mode:

Task	Command
Show the status of the NCIA server.	<b>show ncia server</b> [ <i>server-number</i> ]
Show the status of the NCIA client.	<b>show ncia client</b> [ <i>sap-list</i> ] [ <i>ip-address</i> ]
Terminate an NCIA client connection.	<b>clear ncia client</b> [ <i>ip-address</i> ]
Show the status of an NCIA circuit.	<b>show ncia circuits</b> [ <i>id-number</i> ]
Drop an NCIA circuit.	<b>clear ncia circuit</b> [ <i>id-number</i> ]
Terminate the active connection to the specified client and release all control blocks of the registered client.	<b>clear ncia client registered</b> [ <i>ip-address</i> ]
Stop an NCIA server.	<b>ncia stop</b>
Restart an NCIA server.	<b>ncia start</b>

## NCIA Server Configuration Examples

The following sections provide NCIA Server configuration examples:

- NCIA Server Session to Local Token Ring Using DLSw+ Local Switch Example
- NCIA Server Session with DLSw+ Example
- NCIA Server Session with DSPU Example
- NCIA Server Session with RSRB Example

### NCIA Server Session to Local Token Ring Using DLSw+ Local Switch Example

Figure 123 illustrates the use of DLSw+ local peer with an NCIA Server session to a local Token Ring.

**Figure 123 NCIA Server Session to Local Token Ring Using DLSw+ Local Switch**

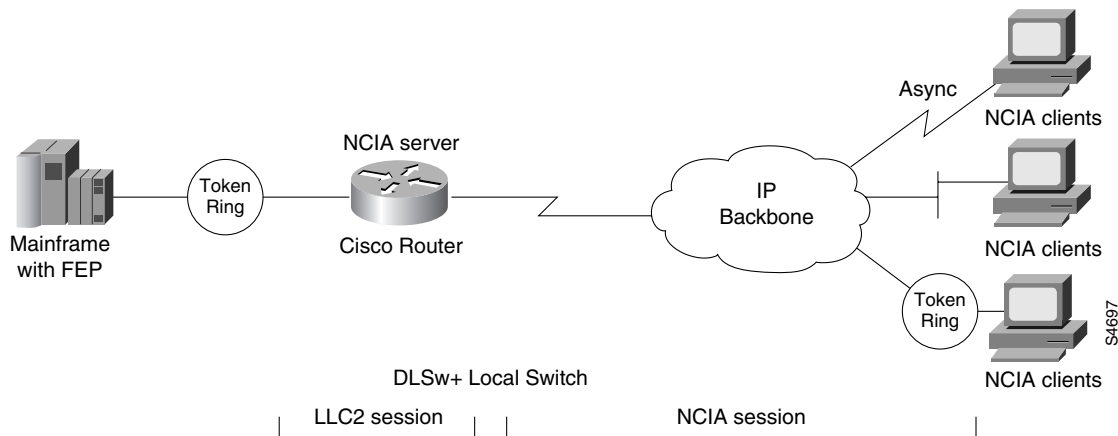

The following is a configuration file for the network example shown in Figure 123:

```
source-bridge ring-group 44
dlsw local-peer
ncia server 1 10.2.20.4 4000.3174.0001 4000.0000.0001 128
!
interface token ring 0
ring-speed 16
source-bridge 21 3 44
```

## NCIA Server Session with DLSw+ Example

Figure 124 illustrates the use of DLSw+ with an NCIA Server session.

**Figure 124 NCIA Server Session with DLSw+**

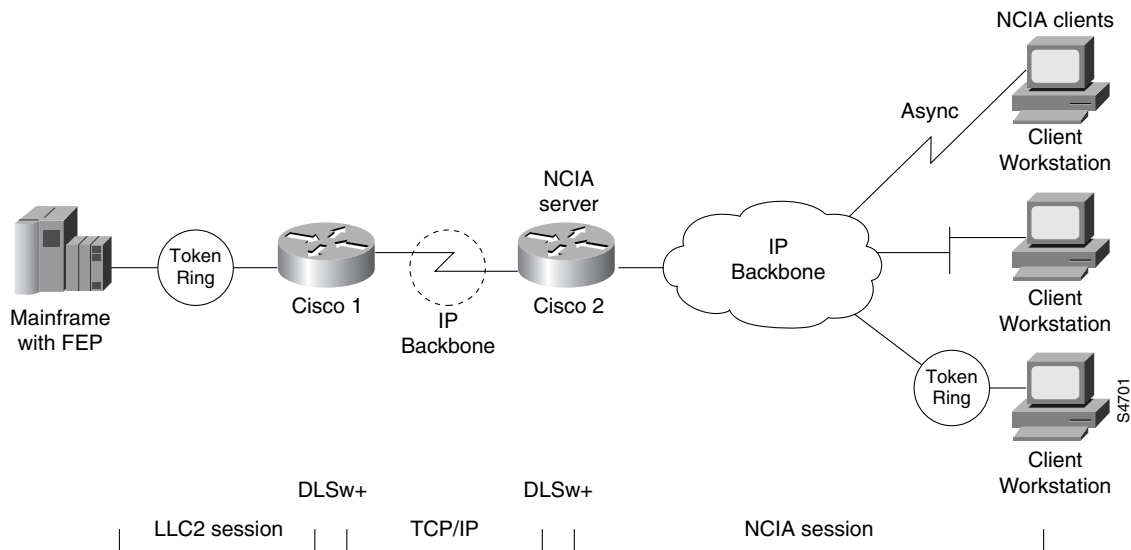

The following is a configuration file for the network example shown in Figure 124:

```
source-bridge ring-group 44
dlsw local-peer peer-id 10.2.20.4
dlsw remote-peer 0 tcp 10.2.20.3
ncia server 1 10.2.20.4 4000.3174.0001 4000.0000.0001 128
```

## NCIA Server Session with DSPU Example

Figure 125 illustrates an NCIA Server session with RSRB/DLSw+ and DSPU.

**Figure 125 NCIA Server Session with RSRB/DLSw+ and DSPU**

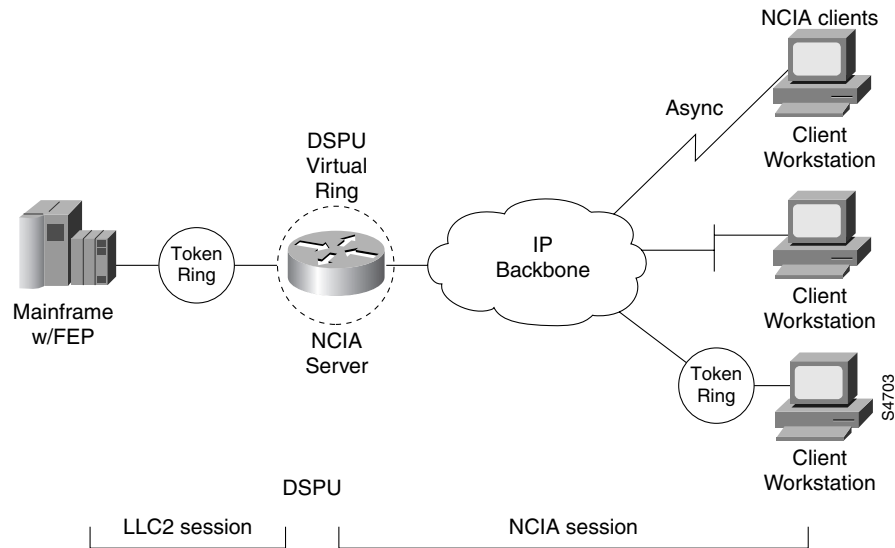

The following is a configuration file for the network example shown in Figure 125:

```
ncia server 1 10.2.20.4 4000.3745.0001 4000.0000.0001 128
!
dspu ncia 1
dspu ncia enable-pu lsap 8
!
dspu host HOST-9370 xid-snd 11100001 rmac 4000.1060.1000 rsap 4 lsap 4
!
dspu pu CISCOPU-A xid-rcv 01700001
dspu lu 2 6 host HOST-9370 2
!
interface TokenRing 0
ring-speed 16
llc2 xid-retry-time 0
dspu enable-host lsap 4
dspu start HOST-9370
```

## NCIA Server Session with RSRB Example

Figure 126 illustrates the use of RSRB with an NCIA Server session.

**Figure 126 NCIA Server Session with RSRB**

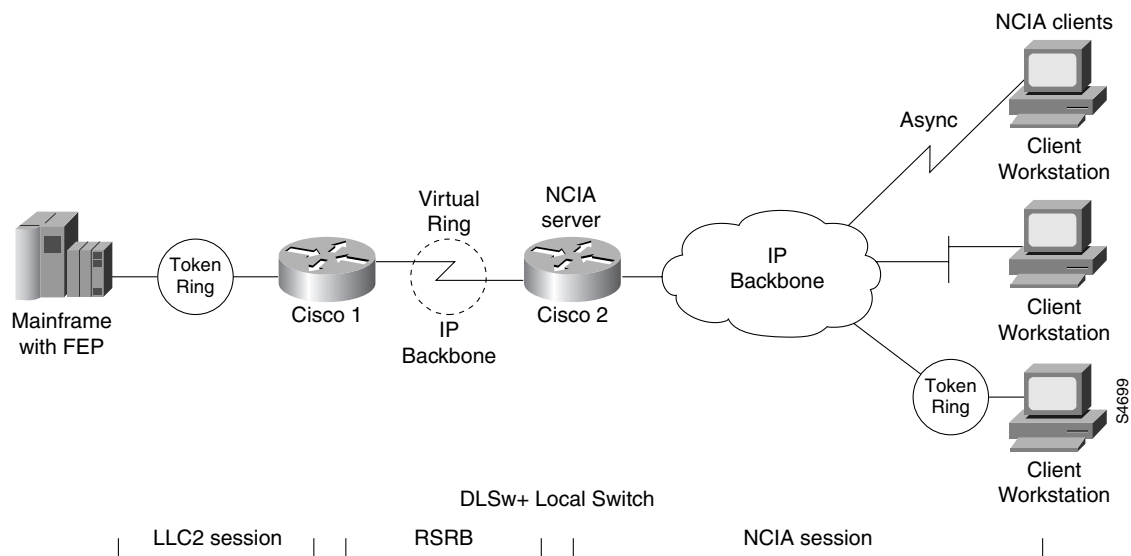

The following is a configuration file for router Cisco 2 for the network example shown in Figure 126:

```

source-bridge ring-group 44
source-bridge ring-group 22
source-bridge remote-peer 22 tcp 10.2.20.3
source-bridge remote-peer 22 tcp 10.2.20.4
dlsw local-peer
ncia server 1 10.2.20.4 4000.3174.0001 4000.0000.0001 128
ncia rsrb 22 2 33 4 44 1111.1111.2222
    
```