



Chapter Goals

- Explain the difference between RSVP and routing protocols.
- Name the three traffic types supported by RSVP.
- Understand RSVP's different filter and style types.
- Explain the purpose of RSVP tunneling.

Resource Reservation Protocol

Background

The *Resource Reservation Protocol (RSVP)* is a network-control protocol that enables Internet applications to obtain differing qualities of service (QoS) for their data flows. Such a capability recognizes that different applications have different network performance requirements. Some applications, including the more traditional interactive and batch applications, require reliable delivery of data but do not impose any stringent requirements for the timeliness of delivery. Newer application types, including videoconferencing, IP telephony, and other forms of multimedia communications require almost the exact opposite: Data delivery must be timely but not necessarily reliable. Thus, RSVP was intended to provide IP networks with the capability to support the divergent performance requirements of differing application types.

It is important to note that RSVP is not a routing protocol. RSVP works in conjunction with routing protocols and installs the equivalent of dynamic access lists along the routes that routing protocols calculate. Thus, implementing RSVP in an existing network does not require migration to a new routing protocol.

Researchers at the University of Southern California (USC) Information Sciences Institute (ISI) and Xerox's Palo Alto Research Center (PARC) originally conceived RSVP. The Internet Engineering Task Force (IETF) subsequently specified an open version of RSVP in its RFC 2205 based directly on the USC and PARC version. RSVP operational topics discussed in this chapter include data flows, quality of service, session startup, reservation style, and soft state implementation. Figure 48-1 illustrates an RSVP environment.

Figure 48-1 In RSVP, Host Information Is Delivered to Receivers over Data Flows

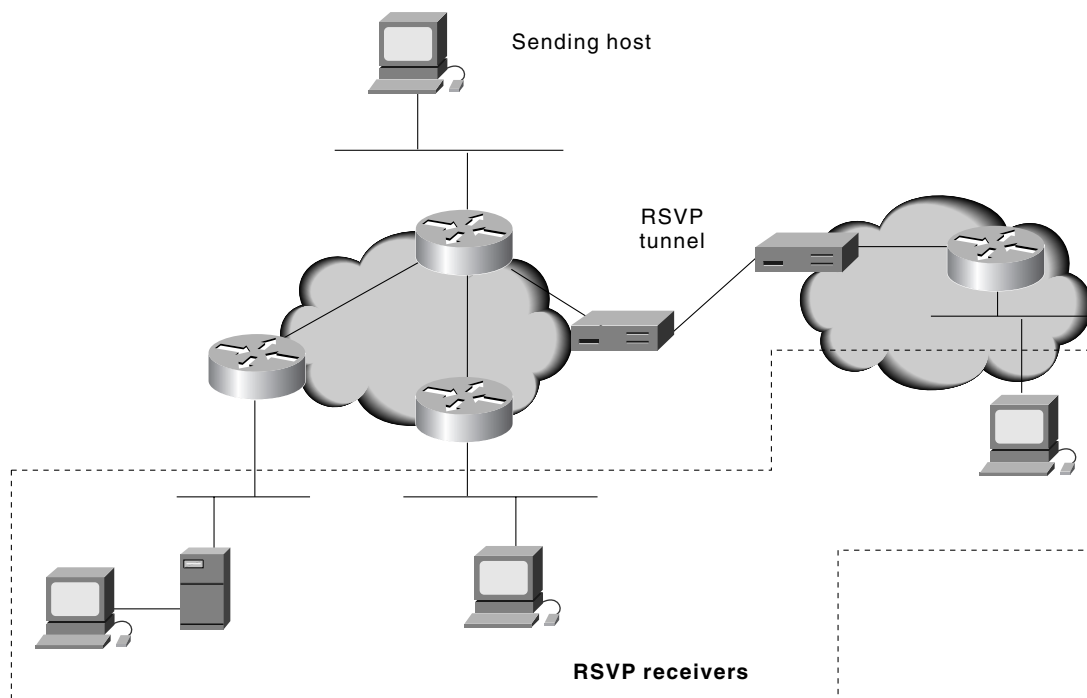

RSVP Data Flows

In RSVP, a data flow is a sequence of datagrams that have the same source, destination (regardless of whether that destination is one or more physical machines), and quality of service. QoS requirements are communicated through a network via a *flow specification*, which is a data structure used by internetwork hosts to request special services from the internetwork. A flow specification describes the level of service required for that data flow. This description takes the form of one of three traffic types. These traffic types are identified by their corresponding RSVP class of service:

1. Best-effort
2. Rate-sensitive
3. Delay-sensitive

Best-effort traffic is traditional IP traffic. Applications include file transfer (such as mail transmissions), disk mounts, interactive logins, and transaction traffic. These types of applications require reliable delivery of data regardless of the amount of time needed to achieve that delivery. Best-effort traffic types rely upon the native TCP mechanisms to resequence datagrams received out of order, as well as to request retransmissions of any datagrams lost or damaged in transit.

Rate-sensitive traffic requires a guaranteed transmission rate from its source to its destination. An example of such an application is H.323 videoconferencing, which is designed to run on ISDN (H.320) or ATM (H.310), but is also found on the Internet and many IP-based intranets. H.323 encoding is a constant (or nearly constant) rate, and it requires a constant transport rate such as is available in a circuit-switched network. By its very nature, IP is packet-switched. Thus, it lacks the mechanisms to support a constant bit rate of service for any given application's data flow. RSVP enables constant bit-rate service in packet-switched networks via its rate-sensitive level of service. This service is sometimes referred to as *guaranteed bit-rate service*.

Delay-sensitive traffic is traffic that requires timeliness of delivery and that varies its rate accordingly. MPEG-II video, for example, averages about 3 to 7 Mbps, depending on the amount of change in the picture. As an example, 3 Mbps might be a picture of a painted wall, although 7 Mbps would be required for a picture of waves on the ocean. MPEG-II video sources send key and delta frames. Typically, 1 or 2 key frames per second describe the whole picture, and 13 or 28 frames (known as delta frames) describe the change from the key frame. Delta frames are usually substantially smaller than key frames. As a result, rates vary quite a bit from frame to frame. A single frame, however, requires delivery within a specific time frame or the CODEC (code-decode) is incapable of doing its job. A specific priority must be negotiated for delta-frame traffic. RSVP services supporting delay-sensitive traffic are referred to as *controlled-delay service* (non-real-time service) and *predictive service* (real-time service).

RSVP Data Flows Process

Unlike routing protocols, RSVP is designed to manage flows of data rather than make decisions for each individual datagram. Data flows consist of discrete sessions between specific source and destination machines. A session is more specifically defined as a simplex flow of datagrams to a particular destination and transport layer protocol. Thus, sessions are identified by the following data: destination address, protocol ID, and destination port. RSVP supports both unicast and multicast simplex sessions.



Note

It is important to note that RSVP sessions are simplex. Thus, a bidirectional exchange of data between a pair of machines actually constitutes two separate RSVP simplex sessions.

A multicast session sends a copy of each datagram transmitted by a single sender to multiple destinations. A unicast session features a single source and destination machine. An RSVP source and destination address can correspond to a unique Internet host. A single host, however, can contain multiple logical senders and receivers distinguished by port numbers, with each port number corresponding to a different application. Given that RSVP tracks such application-specific information, it is possible for a unicast session to result in data being forwarded to multiple applications within the same destination host.

RSVP Quality of Service

In the context of RSVP, *quality of service (QoS)* is an attribute specified in flow specifications that are used to determine the way in which data interchanges are handled by participating entities (routers, receivers, and senders). RSVP is used to specify the QoS by both hosts and routers. Hosts use RSVP to request a QoS level from the network on behalf of an application data stream. Routers use RSVP to deliver QoS requests to other routers along the path(s) of the data stream. In doing so, RSVP maintains the router and host state to provide the requested service.

RSVP Session Startup

To initiate an RSVP multicast session, a receiver first joins the multicast group specified by an IP destination address by using the Internet Group Membership Protocol (IGMP). In the case of a unicast session, unicast routing serves the function that IGMP, coupled with protocol-independent multicast (PIM), serves in the multicast case. After the receiver joins a group, a potential sender starts sending RSVP path messages to the IP destination address. The receiver application receives a path message and

starts sending appropriate reservation-request messages specifying the desired flow descriptors using RSVP. After the sender application receives a reservation-request message, the sender starts sending data packets.

RSVP Reservation Style

Reservation style refers to a set of control options that specify a number of supported parameters. RSVP supports two major classes of reservation: *distinct reservations* and *shared reservations*. Distinct reservations install a flow for each relevant sender in each session. A shared reservation is used by a set of senders that are known not to interfere with each other. Figure 43-2 illustrates distinct and shared RSVP reservation-style types in the context of their scope. Each supported reservation style/scope combination is described following the illustration.

Wildcard-Filter Style

The *wildcard-filter (WF) style* specifies a shared reservation with a wildcard scope. With a WF-style reservation, a single reservation is created into which flows from all upstream senders are mixed. Reservations can be thought of as a shared pipe whose size is the largest of the resource requests for that link from all receivers, independent of the number of senders. The reservation is propagated upstream toward all sender hosts and is automatically extended to new senders as they appear.

Figure 48-2 RSVP Supports Both Distinct Reservations and Shared Reservations

Scope	Reservations	
	Distinct	Shared
Explicit	Fixed-filter (FF) style	Shared-explicit (SE) style
Wildcard	None defined	Wildcard-Filter (WF) style

Fixed-Filter Style

The *fixed-filter (FF) style* specifies a distinct reservation with an explicit scope. With an FF-style reservation, a distinct reservation request is created for data packets from a particular sender. The reservation scope is determined by an explicit list of senders. The total reservation on a link for a given session is the total of the FF reservations for all requested senders. FF reservations that are requested by different receivers but that select the same sender must be merged to share a single reservation in a given node.

Shared-Explicit Style

The *shared-explicit (SE) style* reservation specifies a shared reservation environment with an explicit reservation scope. The SE style creates a single reservation into which flows from all upstream senders are mixed. As in the case of an FF reservation, the set of senders (and, therefore, the scope) is specified explicitly by the receiver making the reservation.

RSVP Reservation Style Implications

WF and SE are both shared reservations that are appropriate for multicast applications in which application-specific constraints make it unlikely that multiple data sources will transmit simultaneously. An example might be audioconferencing, in which a limited number of people talk at once. Each receiver might issue a WF or SE reservation request twice for one audio channel (to allow some overspeaking). The FF style creates independent reservations for the flows from different senders. The FF style is more appropriate for video signals. Unfortunately, it is not possible to merge shared reservations with distinct reservations.

RSVP Soft State Implementation

In the context of an RSVP-enabled network, a *soft state* refers to a state in routers and end nodes that can be updated by certain RSVP messages. The soft state characteristic permits an RSVP network to support dynamic group membership changes and adapt to changes in routing. In general, the soft state is maintained by an RSVP-based network to enable the network to change states without consultation with end points. This contrasts with a circuit-switch architecture, in which an endpoint places a call and, in the event of a failure, places a new call.

RSVP protocol mechanisms provide a general facility for creating and maintaining a distributed reservation state across a mesh of multicast and unicast delivery paths.

To maintain a reservation state, RSVP tracks a soft state in router and host nodes. The RSVP soft state is created and must be periodically refreshed by path and reservation-request messages. If no matching refresh messages arrive before the expiration of a cleanup timeout interval, the state is deleted. The soft state also can be deleted as the result of an explicit teardown message. RSVP periodically scans the soft state to build and forward path and reservation-request refresh messages to succeeding hops.

When a route changes, the next path message initializes the path state on the new route. Future reservation-request messages establish a reservation state. The state on the now-unused segment is timed out. (The RSVP specification requires initiation of new reservations through the network 2 seconds after a topology change.)

When state changes occur, RSVP propagates those changes from end to end within an RSVP network without delay. If the received state differs from the stored state, the stored state is updated. If the result modifies the refresh messages to be generated, refresh messages are generated and forwarded immediately.

RSVP Operational Model

Under RSVP, resources are reserved for simple data streams (that is, unidirectional data flows). Each sender is logically distinct from a receiver, but any application can act as a sender and a receiver. Receivers are responsible for requesting resource reservations. Figure 48-3 illustrates this general operational environment, while the subsequent section provides an outline of the specific sequence of events.

Figure 48-3 The RSVP Operational Environment Reserves Resources for Unidirectional Data Flows

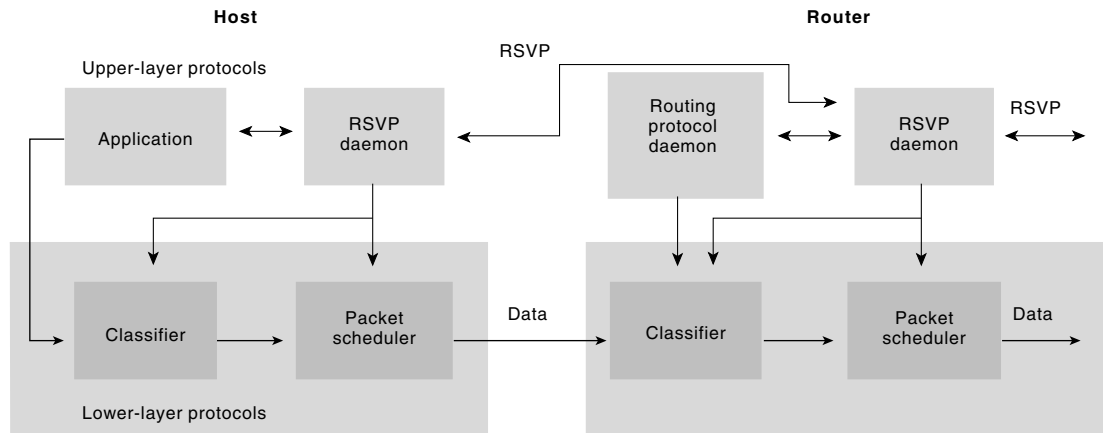

General RSVP Protocol Operation

The RSVP resource-reservation process initiation begins when an RSVP daemon consults the local routing protocol(s) to obtain routes. A host sends IGMP messages to join a multicast group and RSVP messages to reserve resources along the delivery path(s) from that group. Each router that is capable of participating in resource reservation passes incoming data packets to a packet classifier and then queues them as necessary in a packet scheduler. The RSVP packet classifier determines the route and QoS class for each packet. The RSVP scheduler allocates resources for transmission on the particular data link layer medium used by each interface. If the data link layer medium has its own QoS management capability, the packet scheduler is responsible for negotiation with the data link layer to obtain the QoS requested by RSVP.

The scheduler itself allocates packet-transmission capacity on a QoS-passive medium, such as a leased line, and also can allocate other system resources, such as CPU time or buffers. A QoS request, typically originating in a receiver host application, is passed to the local RSVP implementation as an RSVP daemon.

The RSVP protocol then is used to pass the request to all the nodes (routers and hosts) along the reverse data path(s) to the data source(s). At each node, the RSVP program applies a local decision procedure called admission control to determine whether it can supply the requested QoS. If admission control succeeds, the RSVP program sets the parameters of the packet classifier and scheduler to obtain the desired QoS. If admission control fails at any node, the RSVP program returns an error indication to the application that originated the request.

RSVP Tunneling

It is impossible to deploy RSVP or any new protocol at the same moment throughout the entire Internet. Indeed, RSVP might never be deployed everywhere. Therefore, RSVP must provide correct protocol operation even when two RSVP-capable routers are interconnected via an arbitrary cloud of non-RSVP routers. An intermediate cloud that does not support RSVP is incapable of performing resource reservation, so service guarantees cannot be made. However, if such a cloud has sufficient excess capacity, it can provide acceptable and useful real-time service.

To support connection of RSVP networks through non-RSVP networks, RSVP supports tunneling, which occurs automatically through non-RSVP clouds. Tunneling requires RSVP and non-RSVP routers to forward path messages toward the destination address by using a local routing table. When a path message traverses a non-RSVP cloud, the path message copies carry the IP address of the last RSVP-capable router. Reservation-request messages are forwarded to the next upstream RSVP-capable router.

Two arguments have been offered in defense of implementing tunneling in an RSVP environment. First, RSVP will be deployed sporadically rather than universally. Second, by implementing congestion control in situations in which congestion is a known problem, tunneling can be made more effective.

Sporadic, or piecemeal, deployment means that some parts of the network will actively implement RSVP before other parts. If RSVP is required end to end, no benefit is achievable without nearly universal deployment, which is unlikely unless early deployment shows substantial benefits.

Weighted Fair-Queuing Solution

Having the technology to enforce effective resource reservation (such as Cisco's weighted fair-queuing scheme) in a location that presents a bottleneck can have real positive effects. Tunneling presents a risk only when the bottleneck is within a non-RSVP domain and the bottleneck cannot be avoided. Figure 48-4 illustrates an RSVP environment featuring a tunnel between RSVP-based networks.

RSVP Messages

RSVP supports four basic message types: reservation-request messages, path messages, error and confirmation messages, and teardown messages. Each of these is described briefly in the sections that follow.

Figure 48-4 An RSVP Environment Can Feature a Tunnel Between RSVP-Based Networks

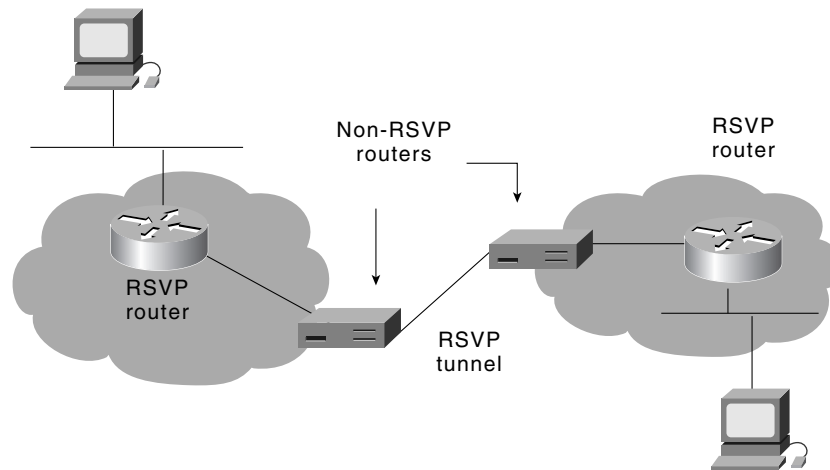

Reservation-Request Messages

A *reservation-request message* is sent by each receiver host toward the senders. This message follows in reverse the routes that the data packets use, all the way to the sender hosts. A reservation-request message must be delivered to the sender hosts so that the hosts can set up appropriate traffic-control parameters for the first hop. RSVP does not send any positive acknowledgment messages.

Path Messages

An *RSVP path message* is sent by each sender along the unicast or multicast routes provided by the routing protocol(s). A path message is used to store the path state in each node. The path state is used to route reservation-request messages in the reverse direction.

Error and Confirmation Messages

Three error and confirmation message forms exist: path-error messages, reservation-request error messages, and reservation-request acknowledgment messages.

Path-error messages result from path messages and travel toward senders. Path-error messages are routed hop by hop using the path state. At each hop, the IP destination address is the unicast address of the previous hop.

Reservation-request error messages result from reservation-request messages and travel toward the receiver. Reservation-request error messages are routed hop by hop using the reservation state. At each hop, the IP destination address is the unicast address of the next-hop node. Information carried in error messages can include the following:

- Admission failure
- Bandwidth unavailable
- Service not supported
- Bad flow specification
- Ambiguous path

Reservation-request acknowledgment messages are sent as the result of the appearance of a reservation-confirmation object in a reservation-request message. This acknowledgment message contains a copy of the reservation confirmation. An acknowledgment message is sent to the unicast address of a receiver host, and the address is obtained from the reservation-confirmation object. A reservation-request acknowledgment message is forwarded to the receiver hop by hop (to accommodate the hop-by-hop integrity-check mechanism).

Teardown Messages

RSVP teardown messages remove the path and reservation state without waiting for the cleanup timeout period. Teardown messages can be initiated by an application in an end system (sender or receiver) or a router as the result of state timeout. RSVP supports two types of teardown messages: path-teardown and reservation-request teardown. *Path-teardown messages* delete the path state (which deletes the reservation state), travel toward all receivers downstream from the point of initiation, and are routed like path messages. *Reservation-request teardown messages* delete the reservation state, travel toward all matching senders upstream from the point of teardown initiation, and are routed like corresponding reservation-request messages.

RSVP Packet Format

Figure 48-5 illustrates the RSVP packet format. The summaries that follow outline the header and object fields illustrated in Figure 48-5.

Figure 48-5 An RSVP Packet Format Consists of Message Headers and Object Fields

RSVP message header fields

Field length,
in bits

4	4	8	16	16	8	8	32	15	1	16
Version	Flags	Type	Checksum	Length	Reserved	Send TTL	Message ID	Reserved	MF	Fragment offset

RSVP object fields

Field length,
in bits

16	8	8	Variable
Length	Class-num	C-Type	Object contents

RSVP Message Header Fields

RSVP message header fields are comprised of the following:

- **Version**—A 4-bit field indicating the protocol version number (currently version 1).
- **Flags**—A 4-bit field with no flags currently defined.

- **Type**—An 8-bit field with six possible (integer) values, as shown in Table 48-1.

Table 48-1 RSVP Message Type Field Values

Value	Message Type
1	Path
2	Reservation-request
3	Path-error
4	Reservation-request error
5	Path-teardown
6	Reservation-teardown
7	Reservation-request acknowledgment

- **Checksum**—A 16-bit field representing a standard TCP/UDP checksum over the contents of the RSVP message, with the checksum field replaced by 0.
- **Length**—A 16-bit field representing the length of this RSVP packet in bytes, including the common header and the variable-length objects that follow. If the More Fragment (MF) flag is set or the Fragment Offset field is nonzero, this is the length of the current fragment of a larger message.
- **Send TTL**—An 8-bit field indicating the IP time-to-live (TTL) value with which the message was sent.
- **Message ID**—A 32-bit field providing a label shared by all fragments of one message from a given next/previous RSVP hop.
- **More fragments (MF) flag**—Low-order bit of a 1-byte word with the other 7 high-order bits specified as reserved. MF is set on for all but the last fragment of a message.
- **Fragment offset**—A 24-bit field representing the byte offset of the fragment in the message

RSVP Object Fields

RSVP object fields are comprised of the following:

- **Length**—Is a 16-bit field containing the total object length in bytes (must always be a multiple of 4 and must be at least 4).
- **Class-num**—Identifies the object class. Each object class has a name. An RSVP implementation must recognize the classes listed in Table 48-2.

The high-order bit of the Class-Num field determines what action a node should take if it does not recognize the Class-Num of an object.

- **C-type**—Object type, unique within Class-Num. The maximum object content length is 65528 bytes. The Class-Num and C-Type fields (together with the flag bit) can be used together as a 16-bit number to define a unique type for each object.

- **Object contents**—The Length, Class-Num, and C-Type fields specify the form of the object content. Refer to Table 48-2 for definitions of the classes of objects that can be included in the object contents.

Table 48-2 RSVP Object Classes

Object Class	Description
Null	Contains a Class-Num of 0, and its C-Type is ignored. Its length must be at least 4 but can be any multiple of 4. A null object can appear anywhere in a sequence of objects, and its contents will be ignored by the receiver.
Session	Contains the IP destination address and possibly a generalized destination port to define a specific session for the other objects that follow (required in every RSVP message).
RSVP Hop	Carries the IP address of the RSVP-capable node that sent this message.
Object Class	Description
Time Values	If present, contains values for the refresh period and the state TTL to override the default values.
Style	Defines the reservation style plus style-specific information that is not a flow-specification or filter-specification object (included in a reservation-request message).
Flow Specification	Defines a desired QoS (included in a reservation-request message).
Filter Specification	Defines a subset of session-data packets that should receive the desired QoS (specified by a flow-specification object within a reservation-request message).
Sender Template	Contains a sender IP address and perhaps some additional demultiplexing information to identify a sender (included in a path message).
Sender TSPEC	Defines the traffic characteristics of a sender's data stream (included in a path message).
Adspec	Carries advertising data in a path message.
Error Specification	Specifies an error (included in a path-error or reservation-request error message).
Policy Data	Carries information that will enable a local policy module to decide whether an associated reservation is administratively permitted (included in a path or reservation-request message).
Integrity	Contains cryptographic data to authenticate the originating node and perhaps to verify the contents of this reservation-request message.
Scope	Is an explicit specification of the scope for forwarding a reservation-request message.
Reservation Confirmation	Carries the IP address of a receiver that requested a confirmation. It appears in either a reservation-request or a reservation-request acknowledgment.

Summary

RSVP is a transport layer protocol that enables a network to provide differentiated levels of service to specific flows of data. Ostensibly, different application types have different performance requirements. RSVP acknowledges these differences and provides the mechanisms necessary to detect the levels of performance required by different applications and to modify network behaviors to accommodate those required levels. Over time, as time and latency-sensitive applications mature and proliferate, RSVP's capabilities will become increasingly important.

Review Questions

Q—*Is it necessary to migrate away from your existing routing protocol to support RSVP?*

A—RSVP is *not* a routing protocol. Instead, it was designed to work in conjunction with existing routing protocols. Thus, it is not necessary to migrate to a new routing protocol to support RSVP.

Q—*Identify the three RSVP levels of service, and explain the difference among them.*

A—RSVP's three levels of service include best-effort, rate-sensitive, and delay-sensitive service. Best-effort service is used for applications that require reliable delivery rather than a timely delivery. Rate-sensitive service is used for any traffic that is sensitive to variation in the amount of bandwidth available. Such applications include H.323 videoconferencing, which was designed to run at a nearly constant rate. RSVP's third level of service is delay-sensitive service. Delay-sensitive traffic requires timely but not reliable delivery of data.

Q—*What are the two RSVP reservation classes, and how do they differ?*

A—A reservation style is a set of control options that defines how a reservation operates. RSVP supports two primary types of reservation styles: distinct reservations and shared reservations. A distinct reservation establishes a flow for each sending device in a session. Shared reservations aggregate communications flows for a set of senders. Each of these two reservation styles is defined by a series of filters.

Q—*What are RSVP filters?*

A—A filter in RSVP is a specific set of control options that specifies operational parameters for a reservation. RSVP's styles include wildcard-filter (WF), fixed-filter (FF), and shared-explicit (SE) filters.

Q—*How can RSVP be used through network regions that do not support RSVP?*

A—RSVP supports tunneling through network regions that do not support RSVP. This capability was developed to enable a phased-in implementation of RSVP.

For More Information

- <http://www.ietf.org/rfc/rfc2205.txt>
- http://www.cisco.com/univercd/cc/td/doc/cisintwk/ito_doc/rsvp.htm