



Configuring Content Switching

This chapter describes how to configure content switching and contains these sections:

- [Configuring the Single Subnet \(Bridge\) Mode, page 4-2](#)
- [Configuring the Secure \(Router\) Mode, page 4-4](#)
- [Configuring Fault Tolerance, page 4-5](#)
- [Configuring HSRP, page 4-9](#)



Note

All examples assume that the **ip slb mode csm** command has been entered as described in [Chapter 3, “Configuring the Content Switching Module.”](#)

Configuring the Single Subnet (Bridge) Mode

In the single subnet (bridge) mode configuration, the client-side and server-side VLANs are on the same subnets. [Figure 4-1](#) shows how the single subnet (bridge) mode configuration is set up.

Figure 4-1 Single Subnet (Bridge) Mode Configuration

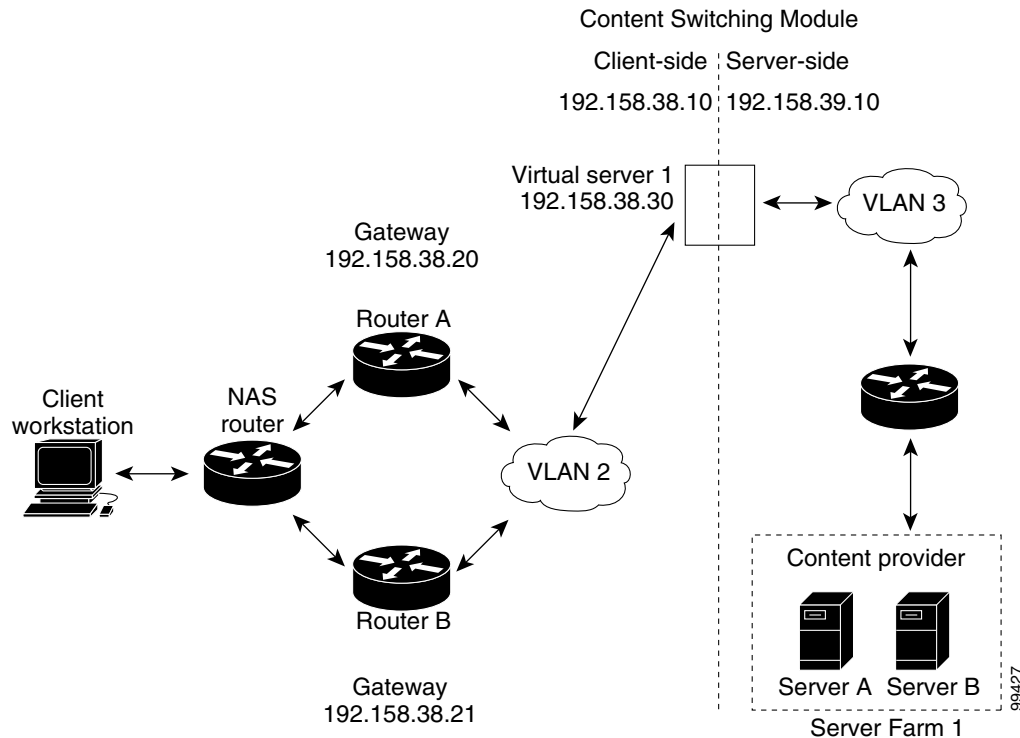

Note

The addresses in [Figure 4-1](#) refer to the steps in the following task table.



Note

You configure single subnet (bridge) mode by assigning the same IP address to the CSM client and server VLANs.

To configure content switching for the single subnet (bridge) mode, perform this task:

	Command	Purpose
Step 1	Router(config-module-csm)# vlan database	Enters the VLAN mode ¹ .
Step 2	Router(vlan)# vlan 2	Configures a client-side VLAN ² .
Step 3	Router(vlan)# vlan 3	Configures a server-side VLAN.
Step 4	Router(vlan)# exit	Exits to have the configuration take effect.
Step 5	Router(config-module-csm)# vlan 2 client	Creates the client-side VLAN 2 and enters the SLB VLAN mode ¹ .

	Command	Purpose
Step 6	Router(config-slb-vlan-client)# ip addr 192.158.38.10 255.255.255.0	Assigns the CSM IP address on VLAN 2.
Step 7	Router(config-slb-vlan-client)# gateway 192.158.38.20	Defines the client-side VLAN gateway to Router A.
Step 8	Router(config-slb-vlan-client)# gateway 192.158.38.21	Defines the client-side VLAN gateway to Router B.
Step 9	Router(config-slb-vserver)# vlan 3 server	Creates the server-side VLAN 3 and enters the SLB VLAN mode.
Step 10	Router(config-slb-vlan-client)# ip addr 192.158.38.10 255.255.255.0	Assigns the CSM IP address on VLAN 3.
Step 11	Router(config-slb-vlan-client)# exit	Exits the submode.
Step 12	Router(config-module-csm)# vserver vip1	Creates a virtual server and enters the SLB <i>vserver</i> mode.
Step 13	Router(config-slb-vserver)# virtual 192.158.38.30 tcp www	Creates a virtual IP address.
Step 14	Router(config-slb-vserver)# serverfarm farm1	Associates the virtual server with the server farm ³ .
Step 15	Router(config-module-csm)# inservice	Enables the server.

1. Enter the **exit** command to leave a mode or submode. Enter the **end** command to return to the menu's top level.
2. The **no** form of this command restores the defaults.
3. This step assumes that the server farm has already been configured. (See the "Configuring Server Farms" section on page 3-12.)



Note Set the server's default routes to Router A's gateway (192.158.38.20) or Router B's gateway (192.158.38.21).

Configuring the Secure (Router) Mode

In secure (router) mode, the client-side and server-side VLANs are on different subnets. [Figure 4-2](#) shows how the secure (router) mode configuration is set up.

Figure 4-2 Secure (Router) Mode Configuration

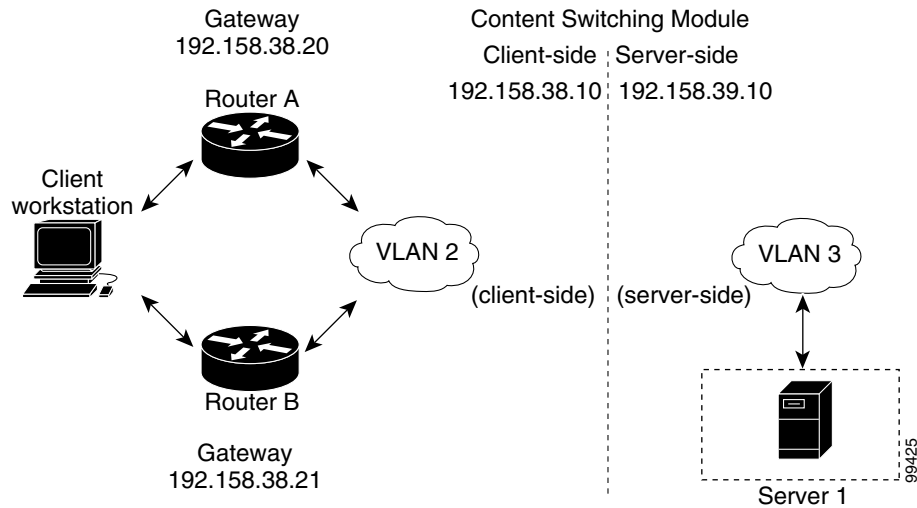

Note

The addresses in [Figure 4-2](#) refer to the steps in the following task table.

To configure content switching in secure (router) mode, perform this task:

	Command	Purpose
Step 1	Router(config-module-csm)# vlan database	Enters the VLAN mode ¹ .
Step 2	Router(vlan)# vlan 2	Configures a client-side VLAN ² .
Step 3	Router(vlan)# vlan 3	Configures a server-side VLAN.
Step 4	Router(vlan)# exit	Exits to have the configuration take effect.
Step 5	Router(config-module-csm)# vlan 2 client	Creates the client-side VLAN 2 and enters the SLB VLAN mode.
Step 6	Router(config-slb-vlan-client)# ip addr 192.158.38.10 255.255.255.0	Assigns the CSM IP address on VLAN 2.
Step 7	Router(config-slb-vlan-client)# gateway 192.158.38.20	Defines the client-side VLAN gateway to Router A.
Step 8	Router(config-slb-vlan-client)# gateway 192.158.38.21	Defines the client-side VLAN gateway to Router B.
Step 9	Router(config-module-csm)# vlan 3 server	Creates the server-side VLAN 3 and enters the SLB VLAN mode.
Step 10	Router(config-slb-vlan-server)# ip addr 192.158.39.10 255.255.255.0	Assigns the CSM IP address on VLAN 3.
Step 11	Router(config-slb-vlan-server)# exit	Exits the submode.

	Command	Purpose
Step 12	Router(config-module-csm) # vserver VIP1	Creates a virtual server and enters the SLB <i>vserver</i> mode.
Step 13	Router(config-slb-vserver) # virtual 192.158.38.30 tcp www	Creates a virtual IP address.
Step 14	Router(config-slb-vserver) # serverfarm farm1	Associates the virtual server with the server farm ³ .
Step 15	Router(config-module-csm) # inservice	Enables the server.

1. Enter the **exit** command to leave a mode or submode. Enter the **end** command to return to the menu's top level.
2. The **no** form of this command restores the defaults.
3. This step assumes that the server farm has already been configured. (See the "Configuring Server Farms" section on page 3-12.)

**Note**

Set the server's default routes to the CSM's IP address (192.158.39.10).

Configuring Fault Tolerance

This section describes a fault-tolerant configuration. In this configuration, two separate Catalyst 6500 series chassis each contain a CSM.

**Note**

You can also create a fault-tolerant configuration with two CSMs in a single Catalyst 6500 series chassis. You also can create a fault-tolerant configuration in either the secure (router) mode or nonsecure (bridge) mode.

In the secure (router) mode, the client-side and server-side VLANs provide the fault-tolerant (redundant) connection paths between the CSM and the routers on the client side and the servers on the server side. In a redundant configuration, two CSMs perform active and standby roles. Each CSM contains the same IP, virtual server, server pool, and real server information. From the client-side and server-side networks, each CSM is configured identically. The network sees the fault-tolerant configuration as a single CSM.

**Note**

When you configure multiple fault-tolerant CSM pairs, do not configure multiple CSM pairs to use the same FT VLAN. Use a different FT VLAN for each fault-tolerant CSM pair.

Configuring fault tolerance requires the following:

- Two CSMs that are installed in the Catalyst 6500 series chassis.
- Identically configured CSMs. One CSM is configured as the active; the other is configured as the standby.
- Each CSM connected to the same client-side and server-side VLANs.
- Communication between the CSMs provided by a shared private VLAN.
- A network that sees the redundant CSMs as a single entity.
- Connection redundancy by configuring a link that has a 1-GB per-second capacity. Enable the calendar in the switch Cisco IOS software so that the CSM state change gets stamped with the correct time.

The following command enables the calendar:

```
Cat6k-2# conf t
Cat6k-2(config)# clock timezone WORD offset from UTC
Cat6k-2(config)# clock calendar-valid
```

Because each CSM has a different IP address on the client-side and server-side VLAN, the CSM can issue health monitor probes (see the “Configuring Probes for Health Monitoring” section on page 6-1) to the network and receive responses. Both the active and standby CSMs send probes while operational. If the passive CSM assumes control, it knows the status of the servers because of the probe responses it has received.

Connection replication supports both non-TCP connections and TCP connections. Enter the **replicate csrp {sticky | connection}** command in the virtual server mode to configure replication for the CSMs.



Note

The default setting for the **replicate** command is disabled.

To use connection replication for connection redundancy, use these commands:

```
Cat6k-2# conf t
Cat6k-2(config)# no ip igmp snooping
```

If no router is present on the server-side VLAN, then each server’s default route points to the aliased IP address.

Figure 4-3 shows how the secure (router) mode fault-tolerant configuration is set up.

Figure 4-3 Fault-Tolerant Configuration

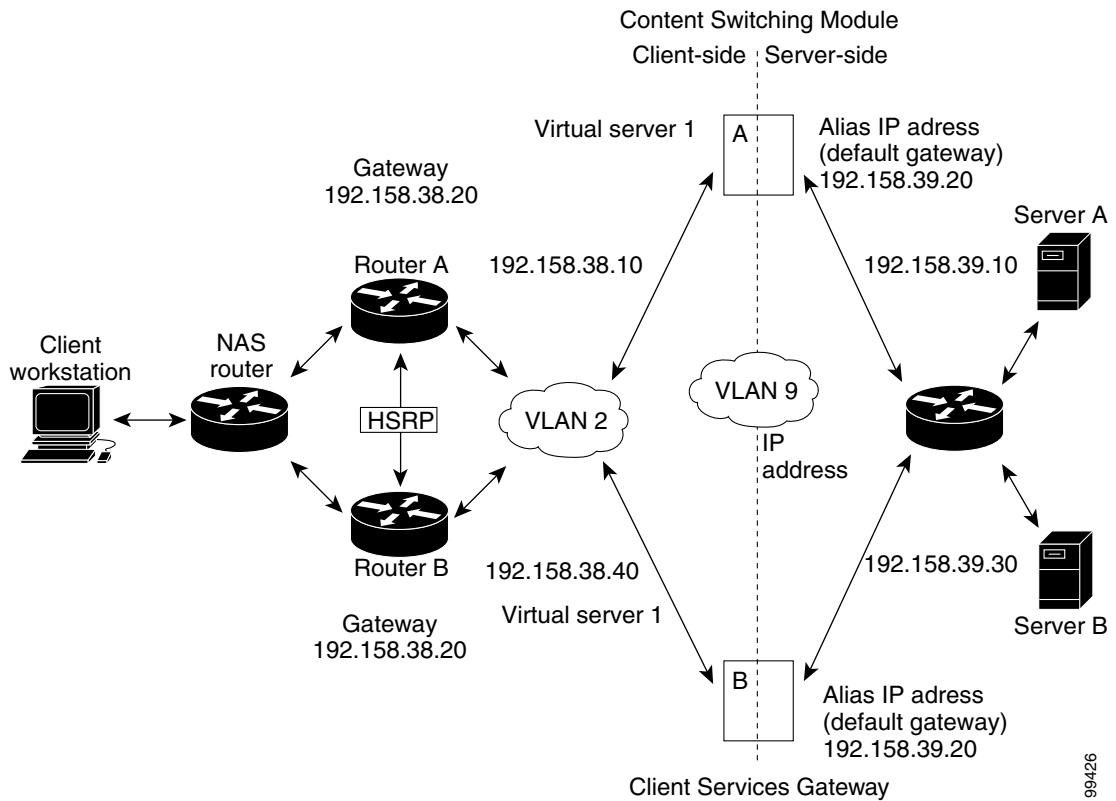

99426



Note The addresses in [Figure 4-3](#) refer to the steps in the following two task tables.

To configure the active (A) CSM for fault tolerance, perform this task:

	Command	Purpose
Step 1	Router(config-module-csm)# vlan 2 client	Creates the client-side VLAN 2 and enters the SLB VLAN mode ¹ .
Step 2	Router(config-slb-vlan-client)# ip addr 192.158.38.10 255.255.255.0	Assigns the content switching IP address on VLAN 2.
Step 3	Router(config-slb-vlan-client)# gateway 192.158.38.20	(Optional) Defines the client-side VLAN gateway for an HSRP enabled gateway.
Step 4	Router(config-module-csm)# vserver vip1	Creates a virtual server and enters the SLB vserver mode.

	Command	Purpose
Step 5	Router(config-slb-vserver)# virtual 192.158.38.30 tcp www	Creates a virtual IP address.
Step 6	Router(config-module-csm)# inservice	Enables the server.
Step 7	Router(config-module-csm)# vlan 3 server	Creates the server-side VLAN 3 and enters the SLB VLAN mode.
Step 8	Router(config-slb-vlan-server)# ip addr 192.158.39.10 255.255.255.0	Assigns the CSM IP address on VLAN 3.
Step 9	Router(config-slb-vlan-server)# alias ip addr 192.158.39.20 255.255.255.0	Assigns the default route for VLAN 3.
Step 10	Router(config-slb-vlan-server) vlan 9	Defines VLAN 9 as a fault-tolerant VLAN.
Step 11	Router(config-module-csm)# ft group ft-group-number vlan 9	Creates the content switching active and standby (A/B) group VLAN 9.
Step 12	Router(config-module-csm)# vlan database	Enters the VLAN mode ¹ .
Step 13	Router(vlan)# vlan 2	Configures a client-side VLAN 2 ² .
Step 14	Router(vlan)# vlan 3	Configures a server-side VLAN 3.
Step 15	Router(vlan)# vlan 9	Configures a fault-tolerant VLAN 9.
Step 16	Router(vlan)# exit	Enters the exit command to have the configuration take affect.

1. Enter the **exit** command to leave a mode or submode. Enter the **end** command to return to the menu's top level.
2. The **no** form of this command restores the defaults.

To configure the standby (B) CSM for fault tolerance, perform this task (see [Figure 4-3](#)):

	Command	Purpose
Step 1	Router(config-module-csm)# vlan 2 client	Creates the client-side VLAN 2 and enters the SLB VLAN mode ¹ .
Step 2	Router(config-slb-vlan-client)# ip addr 192.158.38.40 255.255.255.0	Assigns the Content Switching IP address on VLAN 2.
Step 3	Router(config-module-csm) vlan 9	Defines VLAN 9 as a fault-tolerant VLAN.
Step 4	Router(config-slb-vlan-client)# gateway 192.158.38.20	Defines the client-side VLAN gateway.
Step 5	Router(config-module-csm)# vserver vip1	Creates a virtual server and enters the SLB <i>vserver</i> mode.
Step 6	Router(config-slb-vserver)# virtual 192.158.38.30 tcp www	Creates a virtual IP address.
Step 7	Router(config-module-csm)# inservice	Enables the server.
Step 8	Router(config-module-csm)# vlan 3 server	Creates the server-side VLAN 3 and enters the SLB <i>vlan</i> mode.
Step 9	Router(config-slb-vserver)# ip addr 192.158.39.30 255.255.255.0	Assigns the CSM IP address on VLAN 3.
Step 10	Router(config-slb-vserver)# alias 192.158.39.20 255.255.255.0	Assigns the default route for VLAN 2.

	Command	Purpose
Step 11	Router(config-module-csm)# ft group <i>ft-group-number</i> vlan 9	Creates the CSM active and standby (A/B) group VLAN 9.
Step 12	Router(config-module-csm)# show module csm <i>module</i> ft	Displays the state of the fault tolerant system.

1. Enter the **exit** command to leave a mode or submenu. Enter the **end** command to return to the menu's top level.

Configuring HSRP

This section provides an overview of a Hot Standby Router Protocol (HSRP) configuration (see [Figure 4-4](#)) and describes how to configure the CSMs with HSRP and CSM failover on the Catalyst 6500 series switches.

HSRP Configuration Overview

[Figure 4-4](#) shows that two Catalyst 6500 series switches, Switch 1 and Switch 2, are configured to route from a client-side network (10.100/16) to an internal CSM client network (10.6/16, VLAN 136) through an HSRP gateway (10.100.0.1). The configuration shows the following:

- The client-side network is assigned an HSRP group ID of HSRP ID 2.
- The internal CSM client network is assigned an HSRP group ID of HSRP ID 1.



Note

HSRP group 1 must have tracking turned on so that it can track the client network ports on HSRP group 2. When HSRP group 1 detects any changes in the active state of those ports, it duplicates those changes so that both the HSRP active (Switch 1) and HSRP standby (Switch 2) switches share the same knowledge of the network.

In the example configuration, two CSMs (one in Switch 1 and one in Switch 2) are configured to forward traffic between a client-side and a server-side VLAN:

- Client VLAN 136



Note

The client VLAN is actually an internal CSM VLAN network; the actual client network is on the other side of the switch.

- Server VLAN 272

The actual servers on the server network (10.5/1) point to the CSM server network through an aliased gateway (10.5.0.1), allowing the servers to run a secure subnet.

In the example configuration, an EtherChannel is set up with trunking enabled, allowing traffic on the internal CSM client network to travel between the two Catalyst 6500 series switches. The setup is shown in [Figure 4-4](#).



Note

EtherChannel protects against a severed link to the active switch and a failure in a non-CSM component of the switch. EtherChannel also provides a path between an active CSM in one switch and another switch, allowing CSMs and switches to fail over independently, providing an extra level of fault tolerance.

Figure 4-4 HSRP Configuration

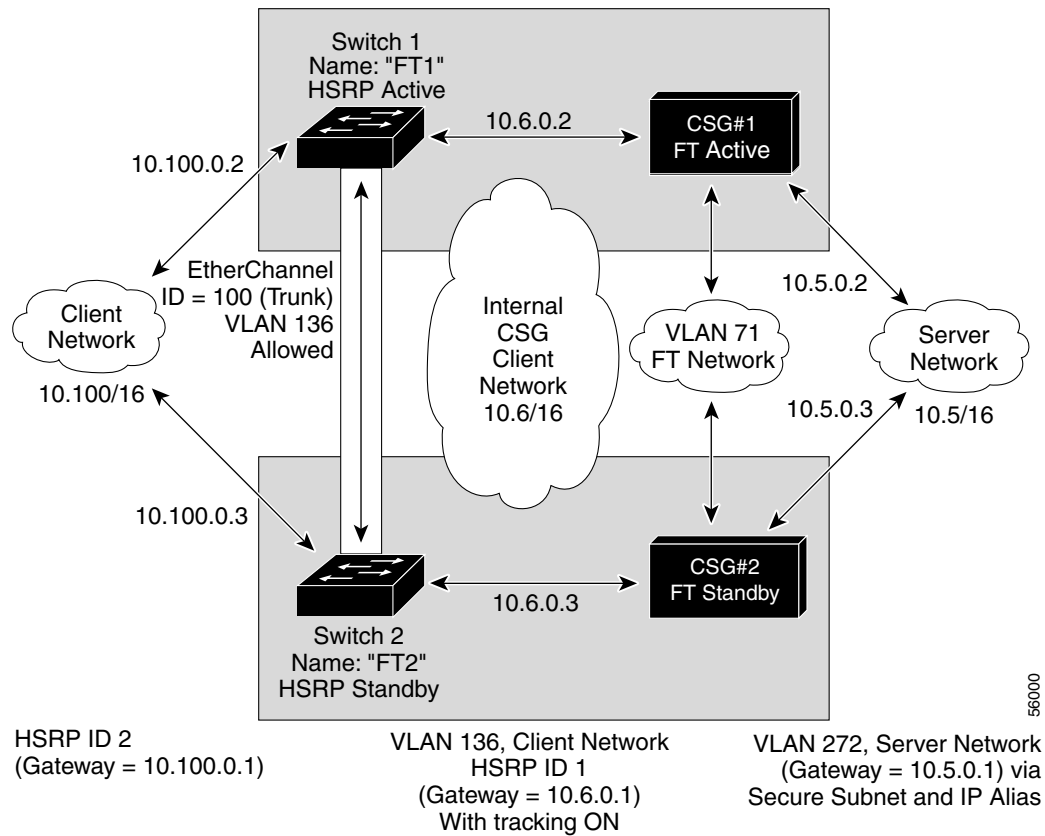

Creating the HSRP Gateway

This procedure describes how to create an HSRP gateway for the client-side network. The gateway is HSRP ID 2 for the client-side network.



Note

In this example, HSRP is set on Fast Ethernet ports 3/6.

To create an HSRP gateway, follow these steps:

Step 1 Configure Switch 1—FT1 (HSRP active) as follows:

```
Router(config)#interface FastEthernet3/6
Router(config)#ip address 10.100.0.2 255.255.0.0
Router(config)#standby 2 priority 110 preempt
Router(config)#standby 2 ip 10.100.0.1
```

Step 2 Configure Switch 2—FT2 (HSRP standby) as follows:

```
Router(config)#interface FastEthernet3/6
Router(config)#ip address 10.100.0.3 255.255.0.0
Router(config)#standby 2 priority 100 preempt
Router(config)#standby 2 ip 10.100.0.1
```

Creating Fault-Tolerant HSRP Configurations

This section describes how to create a fault-tolerant HSRP secure-mode configuration. To create a nonsecure-mode configuration, enter the commands described with these exceptions:

- Assign the same IP address to both the server-side and the client-side VLANs.
- Do not use the **alias** command to assign a default gateway for the server-side VLAN.

To create fault-tolerant HSRP configurations, follow these steps:

Step 1 Configure VLANs on HSRP FT1 as follows:

```
Router(config)# module csm 5
Router(config-module-csm)# vlan 136 client
Router(config-slbn-vlan-client)# ip address 10.6.0.245 255.255.0.0
Router(config-slbn-vlan-client)# gateway 10.6.0.1
Router(config-slbn-vlan-client)# exit

Router(config-module-csm)# vlan 272 server
Router(config-slbn-vlan-server)# ip address 10.5.0.2 255.255.0.0
Router(config-slbn-vlan-server)# alias 10.5.0.1 255.255.0.0
Router(config-slbn-vlan-server)# exit

Router(config-module-csm)# vlan 71

Router(config-module-csm)# ft group 88 vlan 71
Router(config-slbn-ft)# priority 30
Router(config-slbn-ft)# preempt
Router(config-slbn-ft)# exit

Router(config-module-csm)# interface Vlan136
ip address 10.6.0.2 255.255.0.0
standby 1 priority 100 preempt
standby 1 ip 10.6.0.1
standby 1 track Fa3/6 10
```

Step 2 Configure VLANs on HSRP FT2 as follows:

```
Router(config)# module csm 6
Router(config-module-csm)# vlan 136 client
Router(config-slbn-vlan-client)# ip address 10.6.0.246 255.255.0.0
Router(config-slbn-vlan-client)# gateway 10.6.0.1
Router(config-slbn-vlan-client)# exit

Router(config-module-csm)# vlan 272 server
Router(config-slbn-vlan-server)# ip address 10.5.0.3 255.255.0.0
Router(config-slbn-vlan-server)# alias 10.5.0.1 255.255.0.0
Router(config-slbn-vlan-server)# exit

Router(config-module-csm)# vlan 71
```

```
Router(config-module-csm)# ft group 88 vlan 71
Router(config-slb-ft)# priority 20
Router(config-slb-ft)# preempt
Router(config-slb-ft)# exit
```

```
Router(config-module-csm)# interface Vlan136
ip address 10.6.0.3 255.255.0.0
standby 1 priority 100 preempt
standby 1 ip 10.6.0.1
standby 1 track Fa3/6 10
```



Note To allow tracking to work, preempt must be on.

Step 3 Configure EtherChannel on both switches as follows:

```
Router(console)# interface Port-channel100
Router(console)# switchport
Router(console)# switchport trunk encapsulation dot1q
Router(console)# switchport trunk allowed vlan 136
```



Note By default, all VLANs are allowed on the port channel.

Step 4 To prevent problems, remove the server and FT CSM VLANs as follows:

```
Router(console)# switchport trunk remove vlan 71
Router(console)# switchport trunk remove vlan 272
```

Step 5 Add ports to the EtherChannel as follows:

```
Router(console)# interface FastEthernet3/25
Router(console)# switchport
Router(console)# channel-group 100 mode on
```
