



CHAPTER 4

Configuring the PA-MC-STM-1

To continue your PA-MC-STM-1 port adapter installation, you must configure the STM-1 interface. The instructions that follow apply to all supported platforms. Minor differences among the platforms—with Cisco IOS software commands—are noted.

This chapter contains the following sections:

- [Using the EXEC Command Interpreter, page 4-1](#)
- [Configuring the Interface, page 4-2](#)
- [Checking the Configuration, page 4-13](#)



Note

The Cisco 7200 VXR Port Adapter Jacket Card requires no configuration. Configure a port adapter in it as you would any other port adapter.

Using the EXEC Command Interpreter

You modify the configuration of your router or switch through the software command interpreter called the EXEC (also called enable mode). You must enter the privileged level of the EXEC command interpreter with the **enable** command before you can use the **configure** command to configure a new interface or change the existing configuration of an interface. The system prompts you for a password if one has been set.

The system prompt for the privileged level ends with a pound sign (#) instead of an angle bracket (>). At the console terminal, use the following procedure to enter the privileged level:

Step 1 At the user-level EXEC prompt, enter the **enable** command. The EXEC prompts you for a privileged-level password as follows:

```
Router> enable
```

```
Password:
```

Step 2 Enter the password (the password is case sensitive). For security purposes, the password is not displayed. When you enter the correct password, the system displays the privileged-level system prompt (#):

```
Router#
```

Configuring the Interface

After you verify that the new PA-MC-STM-1 is installed correctly (the ENABLED LED goes on), use the privileged-level **configure** command to configure the new interface. Have the following information available:

- Protocols you plan to route on each new interface
- IP addresses, if you plan to configure the interfaces for IP routing
- Bridging protocols you plan to use

If you installed a new PA-MC-STM-1 or if you want to change the configuration of an existing interface, you must enter configuration mode to configure the new interfaces. If you replaced a PA-MC-STM-1 that was previously configured, the system recognizes the new interfaces and brings each of them up in their existing configurations.

For a summary of the configuration options available and instructions for configuring interfaces on a PA-MC-STM-1, refer to the appropriate configuration publications listed in the [“Related Documentation”](#) section on page ix.

You execute configuration commands from the privileged level of the EXEC command interpreter, which usually requires password access. Contact your system administrator, if necessary, to obtain password access. (See the [“Using the EXEC Command Interpreter”](#) section on page 4-1 for an explanation of the privileged level of the EXEC.)

This section contains the following subsections:

- [Shutting Down an Interface, page 4-2](#)
- [Performing a Basic Interface Configuration, page 4-6](#)
- [Configuring the AU-3s and TUG-3s of a PA-MC-STM-1, page 4-9](#)
- [Configuring a Logical Channel Group on an E1 Line, page 4-9](#)
- [Configuring a Logical Channel Group Interface, page 4-10](#)
- [Configuring an E1 Unframed Channel, page 4-10](#)
- [Basic Multi-Router MSP Configuration, page 4-10](#)
- [Basic Single Router APS Configuration, page 4-12](#)

Shutting Down an Interface

Before you remove an interface that you will not replace, or replace port adapters, use the **shutdown** command to shut down (disable) the interfaces to prevent anomalies when you reinstall the new or reconfigured port adapter. When you shut down an interface, it is designated *administratively down* in the **show** command displays.

Follow these steps to shut down an interface:

-
- Step 1** Enter the privileged level of the EXEC command interpreter (also called enable mode). (See the [“Using the EXEC Command Interpreter”](#) section on page 4-1 for instructions.)
- Step 2** At the privileged-level prompt, enter configuration mode and specify that the console terminal is the source of the configuration subcommands, as follows:

```
Router# configure terminal
Enter configuration commands, one per line. End with CNTL/Z.
Router(config)#
```

Step 3 Shut down interfaces by entering the **interface serial** subcommand (followed by the interface address of the interface), and then enter the **shutdown** command. Table 4-1 shows the command syntax.

When you have finished, press **Ctrl-Z**—hold down the **Control** key while you press **Z**—or enter **end** or **exit** to exit configuration mode and return to the EXEC command interpreter.

Table 4-1 shows the **shutdown** command syntax for the supported platforms.

Table 4-1 Syntax of the shutdown Command for the Supported Platforms

| Platform | Command | Example |
|--|---|--|
| FlexWAN module in Catalyst 6000 family switches and Cisco 7600 series Internet Routers | interface , followed by the <i>type (serial) module/bay/port</i> (module-slot-number/port-adapter-bay-number/interface-port-number) shutdown | The example is for interface 0 on a port adapter in module slot 5 in port adapter bay 0. Console# interface serial 5/0/0 Console# shutdown Ctrl-Z Console# |
| Cisco 7200 VXR routers | interface , followed by the <i>type (serial) and slot/port</i> (port-adapter-slot-number/interface-port-number) shutdown | The example is for interface 0 on a port adapter in port adapter slot 6. Router(config-if)# interface serial 6/0 Router(config-if)# shutdown Ctrl-Z Router# |
| Cisco 7201 router | interface , followed by the <i>type (serial) and slot/port</i> (port-adapter-slot-number/interface-port-number) shutdown | The example is for interface 0 and interface 1 on a port adapter in slot 1. Router(config)# interface serial 1/0 Router(config-if)# shutdown Router(config-if)# interface serial 1/1 Router(config-if)# shutdown Ctrl-Z Router# |
| Cisco 7301 router | interface , followed by the <i>type (serial) and slot/port</i> (port-adapter-slot-number/interface-port-number) shutdown | The example is for interface 0 and interface 1 on a port adapter in slot 1. Router(config)# interface serial 1/0 Router(config-if)# shutdown Router(config-if)# interface serial 1/1 Router(config-if)# shutdown Ctrl-Z Router# |
| Cisco 7304 PCI Port Adapter Carrier Card in a Cisco 7304 router | interface , followed by the <i>type (serial) and slot/port</i> (module-slot-number/interface-port-number) shutdown | The example is for interface 0 on a port adapter in a Cisco 7304 PCI Port Adapter Carrier Card in module slot 3 of a Cisco 7304 router. Router(config-if)# interface serial 3/0 Router(config-if)# shutdown Ctrl-Z Router# |

Table 4-1 Syntax of the shutdown Command for the Supported Platforms (continued)

| Platform | Command | Example |
|---|--|--|
| Cisco 7401ASR router | interface , followed by the <i>type</i> (serial) and <i>slot/port</i> (port-adapter-slot-number/interface-port-number) shutdown | The example is for interface 0 and interface 1 on a port adapter in slot 1. Router(config)# interface serial 1/0 Router(config-if)# shutdown Router(config-if)# interface serial 1/1 Router(config-if)# shutdown Ctrl-Z Router# |
| VIP4-80 or VIP6-80 in Cisco 7500 series routers | interface , followed by the <i>type</i> (serial) and <i>slot/port adapter/port</i> (interface-processor-slot-number/port-adapter-slot-number/interface-port-number) shutdown | The example is for interface 0 on a port adapter in port adapter slot 1 of a VIP installed in interface processor slot 1. Router(config-if)# interface serial 1/1/0 Router(config-if)# shutdown Ctrl-Z Router# |

**Note**

If you need to shut down additional interfaces, enter the **interface serial** command (followed by the interface address of the interface) for each of the interfaces on your port adapter. Use the **no shutdown** command to enable the interface.

Step 4 Write the new configuration to NVRAM as follows:

```
Router# copy running-config startup-config
[OK]
Router#
```

The system displays an OK message when the configuration has been stored in NVRAM.

Step 5 Verify that new interfaces are now in the correct state (shut down) using the **show interfaces** command (followed by the interface type and interface address of the interface) to display the specific interface.

Table 4-2 provides examples of the **show interfaces serial** command for the supported platforms.

Table 4-2 Examples of the **show interfaces serial** Command for the Supported Platforms

| Platform | Command | Example |
|--|---|--|
| FlexWAN module in Catalyst 6000 family switches and Cisco 7600 series Internet Routers | show interfaces serial , followed by <i>module/bay/port</i> (module-slot-number/port-adapter-bay-number/interface-port-number) | The example is for interface 0 on a port adapter in module slot 5 in port adapter bay 0. <pre>Console# show interfaces serial 5/0/0</pre> Serial 5/0/0 is administratively down, line protocol is down [Additional display text omitted from this example] |
| Cisco 7200 VXR routers | show interfaces serial , followed by <i>slot/port</i> (port-adapter-slot-number/interface-port-number) | The example is for interface 0 on a port adapter in port adapter slot 6. <pre>Router# show interfaces serial 6/0</pre> Serial 6/0 is administratively down, line protocol is down [Additional display text omitted from this example] |
| Cisco 7201 router | show interfaces serial , followed by <i>slot/port</i> (port-adapter-slot-number/interface-port-number) | The example is for interface 0 on a port adapter in port adapter slot 1. <pre>Router# show interfaces serial 1/0</pre> Serial 1/0 is administratively down, line protocol is down [Additional display text omitted from this example] |
| Cisco 7301 router | interface , followed by the <i>type (serial)</i> and <i>slot/port</i> (port-adapter-slot-number/interface-port-number) | The example is for interface 0 and interface 1 on a port adapter in slot 1. <pre>Router(config)# interface serial 1/0 Router(config-if)# shutdown Router(config-if)# interface serial 1/1 Router(config-if)# shutdown Ctrl-Z Router#</pre> |
| Cisco 7304 PCI Port Adapter Carrier Card in a Cisco 7304 router | show interfaces serial , followed by <i>slot/port</i> (module-slot-number/interface-port-number) | The example is for interface 0 on a port adapter in a Cisco 7304 PCI Port Adapter Carrier Card in module slot 3 of a Cisco 7304 router. <pre>Router# show interfaces serial 3/0</pre> Serial 3/0 is administratively down, line protocol is down [Additional display text omitted from this example] |

Table 4-2 Examples of the `show interfaces serial` Command for the Supported Platforms (continued)

| Platform | Command | Example |
|---|--|---|
| Cisco 7401ASR router | interface , followed by the <i>type (serial)</i> and <i>slot/port</i> (port-adapter-slot-number/interface-port-number) | The example is for interface 0 and interface 1 on a port adapter in slot 1. Router(config)# interface serial 1/0 Router(config-if)# shutdown Router(config-if)# interface serial 1/1 Router(config-if)# shutdown Ctrl-Z Router# |
| VIP4-80 or VIP6-80 in Cisco 7500 series routers | show interfaces serial , followed by <i>slot/port adapter/port</i> (interface-processor-slot-number/port-adapter-slot-number/interface-port-number) | The example is for interface 0 on a port adapter in port adapter slot 1 of a VIP in interface processor slot 1. Router# show interfaces serial 1/1/0 Serial 1/1/0 is administratively down, line protocol is down [Additional display text omitted from this example] |

- Step 6** Re-enable interfaces by doing the following:
- Repeat Step 3 to re-enable an interface. Substitute the **no shutdown** command for the **shutdown** command.
 - Repeat Step 4 to write the new configuration to memory. Use the **copy running-config startup-config** command.
 - Repeat Step 5 to verify that the interfaces are in the correct state. Use the **show interfaces** command followed by the interface type and interface address of the interface.

For complete descriptions of software configuration commands, refer to the publications listed in the “[Related Documentation](#)” section on page ix.

Performing a Basic Interface Configuration

Following are instructions for a basic configuration, which include enabling an interface and configuring the SONET controller. You might also need to enter other configuration subcommands, depending on the requirements for your system configuration and the protocols you plan to route on the interface. For complete descriptions of configuration subcommands and the configuration options available for SONET interfaces, refer to the appropriate software documentation.

In the following procedure, press the **Return** key after each step unless otherwise noted. At any time you can exit the privileged level and return to the user level by entering **disable** at the prompt as follows:

```
Router# disable
```

```
Router>
```

- Step 1** Enter configuration mode and specify that the console terminal is the source of the configuration subcommands, as follows:

```
Router# configure terminal
Enter configuration commands, one per line. End with CNTL/Z.
Router(config)#
```

- Step 2** Configure the SONET controller by entering the **controller sonet** subcommand, followed by the interface address of the controller you plan to configure.

Table 4-3 provides examples of the **controller sonet** subcommand for the supported platforms.

Table 4-3 Examples of the **controller sonet** Subcommand for the Supported Platforms

| Platform | Command | Example |
|--|--|--|
| FlexWAN module in Catalyst 6000 family switches and Cisco 7600 series Internet Routers | controller sonet , followed by <i>module/bay/port</i> (module-slot-number/port-adapter-bay-number/interface-port-number) | The example is for interface 0 on a port adapter in module slot 5 in port adapter bay 0. Console# controller sonet 5/0/0 Console# |
| Cisco 7200 VXR routers | controller sonet , followed by <i>slot/port</i> (port-adapter-slot-number/interface-port-number) | The example is for interface 0 of a port adapter in port adapter slot 6. Router(config)# controller sonet 6/0 Router(config-if)# |
| Cisco 7201 router | controller sonet , followed by <i>slot/port</i> (port-adapter-slot-number/interface-port-number) | The example is for interface 0 of a port adapter in port adapter slot 1. Router(config)# controller sonet 1/0 Router(config-if)# |
| Cisco 7301 router | controller sonet , followed by <i>slot/port</i> (port-adapter-slot-number/interface-port-number) | The example is for interface 0 of a port adapter in port adapter slot 1. Router(config)# controller sonet 1/0 Router(config-if)# |
| Cisco 7304 PCI Port Adapter Carrier Card in a Cisco 7304 router | controller sonet , followed by <i>slot/port</i> (module-slot-number/interface-port-number) | The example is for interface 0 on a port adapter in a Cisco 7304 PCI Port Adapter Carrier Card in module slot 3 of a Cisco 7304 router. Router(config)# controller sonet 3/0 Router(config-if)# |
| Cisco 7401ASR router | controller sonet , followed by <i>slot/port</i> (port-adapter-slot-number/interface-port-number) | The example is for interface 0 of a port adapter in port adapter slot 1. Router(config)# controller sonet 1/0 Router(config-if)# |
| VIP4-80 or VIP6-80 in Cisco 7500 series routers | controller sonet , followed by <i>slot/port adapter/port</i> (interface-processor-slot-number/port-adapter-slot-number/interface-port-number) | The example is for interface 0 in port adapter slot 1 of a VIP in interface processor slot 1. Router(config)# controller sonet 1/1/0 Router(config-controller)# |

- Step 3** Use the **framing {sonet | sdh}** command to set the port to SONET mode or SDH mode, as shown below:

```
Router(config)# controller sonet 1/1/0
Router(config-controller)# framing sdh
```

The default is SONET mode.

- Step 4** Use the **clock source {internal | line}** command to determine if clocking will be obtained locally from the PA-MC-STM-1 or from the network or line, as shown below:

```
Router(config)# controller sonet 1/1/0
Router(config-controller)# clock source internal
```

The default is line.

- Step 5** Use the **aug mapping {au-3 | au-4}** command to determine how the administrative unit groups (AUGs) will be mapped. (See [Figure 4-1](#).) The example shown below configures the AUG as AU-3:

```
Router(config)# controller sonet 1/1/0
Router(config-controller)# aug mapping au-3
```

When the AUG is configured to be AU-3, the following muxing, alignment, and mapping will be configured:

```
C-12 <--> VC-12 <--> TU-12 <--> TUG-2 <--> VC-3 <--> AU-3 <--> AUG
```

When the AUG is configured to be AU-4, the following muxing, alignment, mapping will be configured:

```
C-12 <--> VC-12 <--> TU-12 <--> TUG-2 <--> TUG-3 <--> VC-4 <--> AU-4 <--> AUG
```



Note This command is available only when SDH framing is configured

- Step 6** After including all of the configuration subcommands to complete your configuration, press **Ctrl-Z**—hold down the **Control** key while you press **Z**—or enter **end** or **exit** to exit configuration mode and return to the EXEC command interpreter prompt.

- Step 7** Write the new configuration to NVRAM as follows:

```
Router# copy running-config startup-config
[OK]
Router#
```

This completes the procedure for creating a basic configuration.

Configuring the AU-3s and TUG-3s of a PA-MC-STM-1

You can configure each of the administrative unit groups (AUGs) and tributary unit groups (TUGs) of a PA-MC-STM-1 to carry a set of E1 links that are mapped into TU-12s (see [Figure 4-1](#)).

Figure 4-1 PA-MC-STM-1 Multiplexing Structure

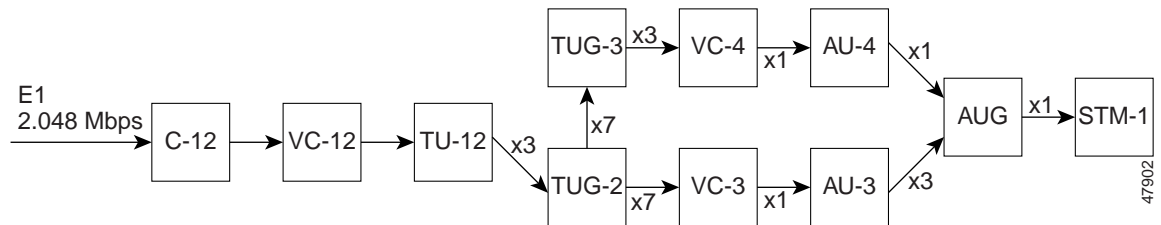

In the following example, SDH framing, internal clock source, AUG mapping au-4, and idle pattern are configured:

```
Router(config)# controller sonet 1/1/0
Router(config-controller)# framing sdh
Router(config-controller)# clock source internal
Router(config-controller)# aug mapping au-4
Router(config-controller)# au-4 1 tug-3 2
Router(config-controller-tug3)# mode c-12
Router(config-controller-tug3)# tug-2 4 e1 channel-group 15 timeslots 1-5, 20-23
Router(config-controller-tug3)# idle pattern 0X0
Router(config-controller-tug3)# exit
Router(config-controller)# exit
```

Configuring a Logical Channel Group on an E1 Line

To configure a logical channel group on an E1 line, use the **tug-2 tug-2# e1 e1# channel-group channel-group# timeslots list-of-timeslots** command where:

- *tug-2#* is a value from 1 to 7
- *e1#* is a value from 1 to 3
- *channel-group#* is a value from 0 to 30
- *list-of-timeslots* can be a value from 1 to 31 or a combination of subranges within the range 1 to 31 (each subrange is a list of time slots that makes up the E1 line).

In the following example, logical channel group 15 on E1 line 1 is configured and channelized time slots 1 to 5 and 20 to 23 are assigned to the newly created logical channel group:

```
Router(config)# controller sonet 1/1/0
Router(config-controller)# framing sdh
Router(config-controller)# aug mapping au-4
Router(config-controller)# au-4 1 tug-3 2
Router(config-controller-tug3)# mode c-12
Router(config-controller-tug3)# tug-2 4 e1 1 channel-group 15 timeslots 1-5, 20-23
Router(config-controller-tug3)# exit
Router(config-controller)# exit
```

Configuring a Logical Channel Group Interface

Once a channel group has been created (see the “[Configuring a Logical Channel Group on an E1 Line](#)” section on page 4-9), interface serial configuration commands may be used as in the example below:

```
Router(config)# controller sonet 1/1/0
Router(config-controller)# framing sdh
Router(config-controller)# aug mapping au-4
Router(config-controller)# au-4 1 tug-3 2
Router(config-controller-tug3)# mode c-12
Router(config-controller-tug3)# tug-2 4 e1 1 channel-group 15 timeslots 1-5, 20-23
Router(config-controller-tug3)# exit
Router(config-controller)# exit
Router(config)# interface serial 1/1/0.1/2/4/1:15
Router(config-if)# ip address 1.1.1.10 255.255.255.252
Router(config-if)# encapsulation ppp
```

Configuring an E1 Unframed Channel

To create an unframed or clear channel logical channel group on an E1 line, use the **tug-2 tug-2# e1 e1# unframed** command, as shown in the example below:

```
Router(config)# controller sonet 1/1/0
Router(config-controller)# au-4 1 tug-3 2
Router(config-controller-tug3)# tug-2 4 e1 1 unframed
```



Note

The channel group is always 0 for unframed E1 lines.

Basic Multi-Router MSP Configuration

The following example shows the configuration of Multiplex Section Protection (MSP) on router A and router B (see [Figure 4-2](#)). In this example, router A is configured with the working controller, and router B is configured with the protect controller. If the working controller on router A becomes unavailable, the connection will automatically switchover to the protect controller on router B. This configuration is typically used to protect against both line card and router failures.

Figure 4-2 Basic Multi-Router MSP Configuration

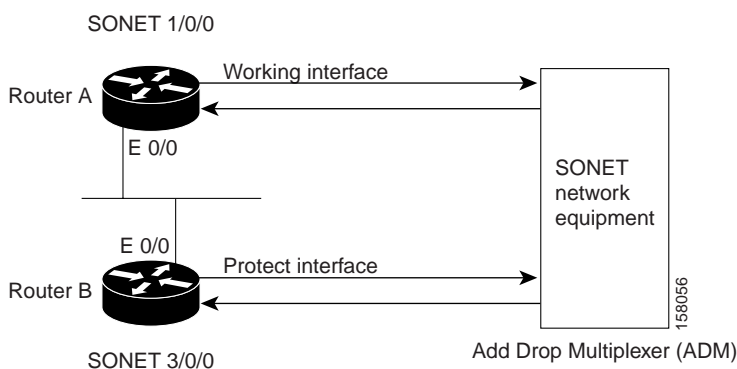

To configure Router A as the working controller, use the following configuration:

```
RouterA# configure terminal
RouterA(config)# interface ethernet 0/0
RouterA(config-if)# ip address 7.7.7.7 255.255.255.0
RouterA(config-if)# exit
RouterA(config)# controller SONET 1/0/0
RouterA(config-controller)# aps group 1
RouterA(config-controller)# aps working 1
RouterA(config-controller)# end
RouterA#
```

To configure Router B as the protect controller, use the following configuration:

```
RouterB# configure terminal
RouterB(config)# interface ethernet 0/0
RouterB(config-if)# ip address 7.7.7.6 255.255.255.0
RouterB(config-if)# exit
RouterB(config)# controller SONET 3/0/0
RouterB(config-controller)# aps group 1
RouterB(config-controller)# aps protect 1 7.7.7.7
RouterB(config-controller)# end
RouterB#
```

To configure serial interfaces on Router A, use the following configuration:

```
RouterA# configure terminal
RouterA(config)# controller SONET 1/0/0
RouterA(config-controller)# au-4 1 tug-3 1
RouterA(config-ctrlr-tug3)# tug-2 1 e1 1 unframed
RouterA(config-controller)# exit
RouterA(config)# interface serial 1/0/0.1/1/1/1:0
RouterA(config-if)# ip address 192.0.1.2 255.255.255.0
RouterA(config-if)# end
RouterA#
```

To configure serial interfaces on Router B, use the following configuration:

```
RouterB# configure terminal
RouterB(config)# controller SONET 3/0/0
RouterB(config-controller)# au-4 1 tug-3 1
RouterB(config-ctrlr-tug3)# tug-2 1 e1 1 unframed
RouterB(config-controller)# exit
RouterB(config)# interface serial 3/0/0.1/1/1/1:0
RouterB(config-if)# ip address 192.0.1.2 255.255.255.0
RouterB(config-if)# end
RouterB#
```

Basic Single Router APS Configuration

The following example shows the configuration of Automatic Protection Switching (APS) on router A (see Figure 4-3). In this example, Router A has both working and protect controllers. If the working controller SONET 1/0/0 becomes unavailable, the connection will automatically switchover to the protect controller SONET 3/0/0. Single router APS configuration is typically used to protect line card failures.

Figure 4-3 Basic Single Router APS Configuration

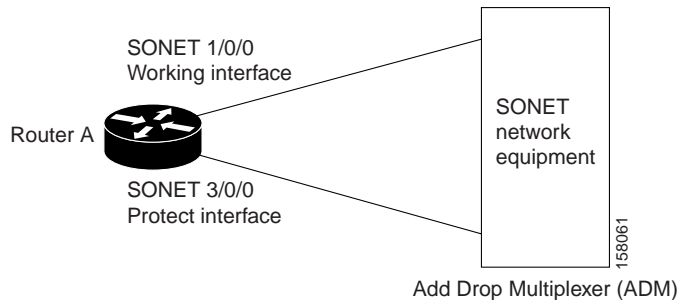

To configure a loopback interface on Router A, use the following configuration:

```
RouterA# configure terminal
RouterA(config)# interface Loopback 0/0
RouterA(config-if)# ip address 7.7.7.7 255.255.255.255
RouterA(config-if)# end
RouterA#
```

Next, to configure working and protect controllers, use the following configuration:

```
RouterA# configure terminal
RouterA(config)# controller SONET 1/0/0
RouterA(config-controller)# aps group 1
RouterA(config-controller)# aps working 1
RouterA(config-controller)# exit
RouterA(config)# controller SONET 3/0/0
RouterA(config-controller)# aps group 1
RouterA(config-controller)# aps protect 1 7.7.7.7
RouterA(config-controller)# end
RouterA#
```

Finally, to configure serial interfaces on both working and protect controllers, use the following configuration:

```
RouterA(config)# controller SONET 1/0/0
RouterA(config-controller)# au-4 1 tug-3 1
RouterA(config-ctrlr-tug3)# tug-2 1 e1 1 unframed
RouterA(config-controller)# exit
RouterA(config)# interface serial 1/0/0.1/1/1:0
RouterA(config-if)# ip address 192.0.1.2 255.255.255.0
RouterA(config-if)# exit
RouterA(config)# controller SONET 3/0/0
RouterA(config-controller)# au-4 1 tug-3 1
RouterA(config-ctrlr-tug3)# tug-2 1 e1 1 unframed
RouterA(config-controller)# exit
RouterA(config)# interface serial 3/0/0.1/1/1:0
```

```
RouterA(config-if)# ip address 192.0.1.2 255.255.255.0
RouterA(config-if)# end
```

**Note**

MSP is only supported at the SONET controller level. Individual E1 level protection is not supported with PA-MC-STM1.

Checking the Configuration

After configuring the new interface, use the **show** commands to display the status of the new interface or all interfaces, and use the **ping** and **loopback** commands to check connectivity. This section includes the following subsections:

- [Using show Commands to Verify the New Interface Status, page 4-13](#)
- [Using the ping Command to Verify Network Connectivity, page 4-25](#)
- [Using loopback Commands, page 4-25](#)

Using show Commands to Verify the New Interface Status

This section demonstrates how you can use the **show** commands to verify that new interfaces are configured and operating correctly and that the module appears in them correctly. Sample displays of the output of selected **show** commands appear in the sections that follow. For complete command descriptions and examples, refer to the publications listed in the “[Related Documentation](#)” section on [page ix](#).

If an interface is shut down and you configured it as up, or if the displays indicate that the hardware is not functioning properly, ensure that the interface is properly connected and terminated. If you still have problems bringing up the interface, contact a service representative for assistance.

This section includes the following subsections:

- [Using the show controllers Commands, page 4-14](#)
- [Using the show protocols Command, page 4-14](#)
- [Using the show running-config Command, page 4-15](#)
- [Using the show startup-config Command, page 4-15](#)
- [Using the show version or show hardware Commands, page 4-17](#)
- [Using the show diag Command, page 4-20](#)
- [Using the show interfaces Command, page 4-22](#)

Using the show controllers Commands

Display all the current interface processors and their interfaces using the **show controllers** command.



Note

The outputs that appear in this document may not match the output you receive when running these commands. The outputs in this document are examples only.

The following is an example of the **show controllers** command:

```
Router# show controllers

MEMD at 40000000, 2097152 bytes (unused 3360, recarves 1, lost 0)
RawQ 48000100, ReturnQ 48000108, EventQ 48000110
BufhdrQ 48000128 (2900 items), LovltrQ 48000140 (5 items, 2016 bytes)
IpcbufQ 48000150 (16 items, 4096 bytes)
IpcbufQ_classic 48000148 (8 items, 4096 bytes)
3570 buffer headers (48002000 - 4800FF10)
pool0: 9 buffers, 256 bytes, queue 48000130
pool1: 344 buffers, 1536 bytes, queue 48000138
pool2: 284 buffers, 4544 bytes, queue 48000158
pool3: 4 buffers, 4576 bytes, queue 48000160
slot2: VIP2, hw 2.4, sw 22.20, ccb 5800FF40, cmdq 48000090
software loaded from flash slot0:vip2_22-20.atmdx.191897
IOS (tm) VIP Software (SVIP-DW-M), Experimental Version 11.3
ROM Monitor version 17.0
ATM2/0/0, applique is DS3 (45Mbps)
gfreeq 48000158, lfreeq 48000168 (4544 bytes), throttled 0
rxlo 4, rxhi 284, rxcurr 1, maxrxcurr 5
txq 48001A00, txacc 48001A02 (value 284), txlimit 284
```

Using the show protocols Command

Display protocols configured for the entire system and for specific interfaces using the **show protocols** command.



Note

The outputs that appear in this document may not match the output you receive when running these commands. The outputs in this document are examples only.

The following is an example of the **show protocols** command:

```
Router# show protocols
line protocol is up
```

Using the show running-config Command

Display the running configuration file using the **show running-config** command.

**Note**

The outputs that appear in this document may not match the output you receive when running these commands. The outputs in this document are examples only.

The following is an example of the **show running-config** command:

```
Router# show running-config

Building configuration...
Current configuration:
!
!
!
user add admin uid 0 capability admin-access
!
!
!
hostname CR4430
!
interface ethernet 0
 ip address 10.2.2.8 255.255.255.0
 ip broadcast-address 10.2.2.255
 exit
!
interface ethernet 1
 exit
!
ip default-gateway 10.2.2.1
ip name-server 10.2.2.6
ip route 0.0.0.0 0.0.0.0 10.2.2.1
```

Using the show startup-config Command

Display the configuration stored in the NVRAM using the **show startup-config** command.

**Note**

The outputs that appear in this document may not match the output you receive when running these commands. The outputs in this document are examples only.

The following is an example of the **show startup-config** command:

```
Router# show startup-config

Building configuration...

Current configuration:
!
version 12.0
service timestamps debug uptime
service timestamps log uptime
no service password-encryption
!
hostname rp-3640-2b
!
ip subnet-zero
!
```

```
ip audit notify log
ip audit po max-events 100
!
crypto isakmp policy 1
hash md5
authentication pre-share
crypto isakmp key cisco123 address 95.95.95.2
!
crypto ipsec transform-set rtpset esp-des esp-md5-hmac
!
crypto map rtp 1 ipsec-isakmp
set peer 95.95.95.2
set transform-set rtpset
match address 115
!
interface Ethernet0/0
ip address 98.98.98.1 255.255.255.0
no ip directed-broadcast
!
interface Ethernet0/1
ip address 99.99.99.2 255.255.255.0
no ip directed-broadcast
no ip route-cache
no ip mroute-cache
crypto map rtp
!
interface Ethernet0/2
no ip address
no ip directed-broadcast
shutdown
!
interface Ethernet0/3
no ip address
no ip directed-broadcast
shutdown
!
ip classless
ip route 0.0.0.0 0.0.0.0 99.99.99.1
no ip http server
!
access-list 115 permit ip 98.98.98.0 0.0.0.255 10.103.1.0 0.0.0.255
access-list 115 deny ip 98.98.98.0 0.0.0.255 any
!
line con 0
transport input none
line aux 0
line vty 0 4
login
!
end
```

Using the show version or show hardware Commands

Display the configuration of the system hardware, the number of each interface type installed, the Cisco IOS software version, the names and sources of configuration files, and the boot images, using the **show version** (or **show hardware**) command.



Note

The outputs that appear in this document may not match the output you receive when running these commands. The outputs in this document are examples only.

The following sections provide platform-specific output examples of the **show version** command:

- [Catalyst 6000 Family Switches and Cisco 7600 Series Internet Routers with FlexWAN Module—Example Output of the show version Command, page 4-17](#)
- [Cisco 7200 VXR Routers—Example Output of the show version Command, page 4-18](#)
- [Cisco 7201 Router—Example Output of the show version Command, page 4-18](#)
- [Cisco 7500 Series Routers with VIP—Example Output of the show version Command, page 4-19](#)

Catalyst 6000 Family Switches and Cisco 7600 Series Internet Routers with FlexWAN Module—Example Output of the show version Command

Following is an example of the **show version** command from a Catalyst 6000 family switch with a PA-MC-STM-1 installed:

```

Console# show version

Cisco Internetwork Operating System Software
IOS (tm) MSFC Software (C6MSFC-JSV-M), Version 12.1(20010119:22010)
Copyright (c) 1986-2001 by cisco Systems, Inc.
Compiled Fri 19-Jan-01 14:46 by biff
Image text-base: 0x60008950, data-base: 0x617AC000

ROM: System Bootstrap, Version 12.0(3)XE, RELEASE SOFTWARE
BOOTFLASH: MSFC Software (C6MSFC-BOOT-M), Version 12.0(7)XE1, EARLY DEPLOYMENT )

Switch uptime is 4 hours, 21 minutes
System returned to ROM by reload
System image file is "bootflash:c6msfc-jsv-mz.Feb9"

cisco Cat6k-MSFC (R5000) processor with 114688K/16384K bytes of memory.
Processor board ID SAD03432638
R5000 CPU at 200Mhz, Implementation 35, Rev 2.1, 512KB L2 Cache
Last reset from power-on
Bridging software.
X.25 software, Version 3.0.0.
SuperLAT software (copyright 1990 by Meridian Technology Corp).
TN3270 Emulation software.
1 FlexWAN controller (1 Channelized OC3/STM-1).
1 Virtual Ethernet/IEEE 802.3 interface(s)
1 Channelized OC3/STM-1 port(s)
123K bytes of non-volatile configuration memory.
4096K bytes of packet SRAM memory.

16384K bytes of Flash internal SIMM (Sector size 256K).
Configuration register is 0x100Cisco 7200 VXR Routers

```

Cisco 7200 VXR Routers—Example Output of the show version Command

Following is an example of the **show version** command from a Cisco 7200 VXR router with a PA-MC-STM-1 installed:

```
Router1-VXR> show version

Cisco Internetwork Operating System Software
IOS (tm) 7200 Software (C7200-P-M), Version 12.1(20010104:023621) ]
Copyright (c) 1986-2001 by cisco Systems, Inc.
Compiled Tue 23-Jan-01 15:34 by biff
Image text-base: 0x60008968, data-base: 0x60C56000

ROM: System Bootstrap, Version 12.0(20000211:194150)
BOOTFLASH: 7200 Software (C7200-BOOT-M), Version 12.0(10)S, EARLY DEPLOYMENT RE)

Router1-VXR uptime is 5 days, 20 hours, 48 minutes
System returned to ROM by reload
System image file is "c7200-p-mz"

cisco 7206VXR (NSE-1) processor (revision A) with 114688K/16384K bytes of memor.
Processor board ID 21288237
R7000 CPU at 262Mhz, Implementation 39, Rev 2.1, 256KB L2, 2000KB L3 Cache
6 slot VXR midplane, Version 2.0

Last reset from power-on
X.25 software, Version 3.0.0.
PXF processor tmc is running.
8 Ethernet/IEEE 802.3 interface(s)
1 FastEthernet/IEEE 802.3 interface(s)
63 Serial network interface(s)
1 Channelized T3 port(s)
1 Channelized OC3/STM-1 port(s)
125K bytes of non-volatile configuration memory.

20480K bytes of Flash PCMCIA card at slot 0 (Sector size 128K).
4096K bytes of Flash internal SIMM (Sector size 256K).
Configuration register is 0x0
```

Cisco 7201 Router—Example Output of the show version Command

Following is an example of the **show version** command from a Cisco 7201 router:

```
Router# show version

Cisco IOS Software, 7200 Software (C7200P-ADVENTERPRISEK9-M), Version
12.4(biffDEV.061001), INTERIM SOFTWARE Copyright (c) 1986-2006 by Cisco Systems, Inc.
Compiled Sun 01-Oct-06 23:42 by biff
ROM: System Bootstrap, Version 12.4(4r)XD5, RELEASE SOFTWARE (fc1)
BOOTLDR: Cisco IOS Software, 7200 Software (C7200P-KBOOT-M), Version 12.4(TAZ3DEV.060927),
INTERIM SOFTWARE
c7201alphal uptime is 5 days, 18 hours, 32 minutes System returned to ROM by power-on
System image file is "disk0:c7200p-adventerprisek9-mz.2006-10-01.biffdev"
This product contains cryptographic features and is subject to United States and local
country laws governing import, export, transfer and use. Delivery of Cisco cryptographic
products does not imply third-party authority to import, export, distribute or use
encryption.
Importers, exporters, distributors and users are responsible for compliance with U.S. and
local country laws. By using this product you agree to comply with applicable laws and
regulations. If you are unable to comply with U.S. and local laws, return this product
immediately.
A summary of U.S. laws governing Cisco cryptographic products may be found at:
```

```

http://www.cisco.com/wwl/export/crypto/tool/stqrg.html
If you require further assistance please contact us by sending email to export@cisco.com.
Cisco 7201 (c7201) processor (revision A) with 917504K/65536K bytes of memory.
Processor board ID 222222222222
MPC7448 CPU at 1666Mhz, Implementation 0, Rev 2.2
1 slot midplane, Version 2.255
Last reset from power-on
1 FastEthernet interface
4 Gigabit Ethernet interfaces
2045K bytes of NVRAM.
62443K bytes of USB Flash usbflash0 (Read/Write)
250880K bytes of ATA PCMCIA card at slot 0 (Sector size 512 bytes).
65536K bytes of Flash internal SIMM (Sector size 512K).
Configuration register is 0x2

```

Cisco 7500 Series Routers with VIP—Example Output of the show version Command

Following is an example of the **show version** command from a VIP4-80 in a Cisco 7500 series router with a PA-MC-STM-1 installed:

```

Router# show version

Cisco Internetwork Operating System Software
IOS (tm) RSP Software (RSP-PV-M), Version 12.0(20000912:174226) ]
Copyright (c) 1986-2000 by cisco Systems, Inc.
Compiled Wed 13-Sep-00 04:08 by biff
Image text-base: 0x60010950, data-base: 0x60DA6000

ROM: System Bootstrap, Version 11.1(8)CA1, RELEASE SOFTWARE (fc1)
BOOTFLASH: GS Software (RSP-BOOT-M), Version 11.1(8)CA1, RELEASE SOFTWARE (fc1)
7500_right uptime is 2 minutes
System returned to ROM by reload at 17:20:30 UTC Fri Apr 30 1999
System image file is
"tftp://223.255.254.254//tftpboot-users/halrev312sdevtst/rel091300/bin/rsp-pv-mz091300"

cisco RSP4 (R5000) processor with 131072K/2072K bytes of memory.
R5000 CPU at 200Mhz, Implementation 35, Rev 2.1, 512KB L2 Cache
Last reset from power-on
G.703/E1 software, Version 1.0.
G.703/JT2 software, Version 1.0.
X.25 software, Version 3.0.0.
1 EIP controller (6 Ethernet).
1 VIP4-80 RM7000 controller (1 Channelized OC3/STM-1).
6 Ethernet/IEEE 802.3 interface(s)
1 Serial network interface(s)
1 Channelized OC3/STM-1 port(s)
123K bytes of non-volatile configuration memory.

20480K bytes of Flash PCMCIA card at slot 1 (Sector size 128K).
8192K bytes of Flash internal SIMM (Sector size 256K).
No slave installed in slot 7.
Configuration register is 0x0

```

Using the show diag Command

Display the types of port adapters installed in your system (and specific information about each) using the **show diag slot** command, where *slot* is the *port adapter slot* in a Cisco 7200 VXR router, Cisco 7201 router, Cisco 7301 router, or Cisco 7401ASR router, the *module slot* in a Cisco 7304 PCI Port Adapter Carrier Card in a Cisco 7304 router, and the *interface processor slot* in a Cisco 7500 series router with a VIP. In the FlexWAN module, the **show diag** command is used without the *slot* designation.



Note

The outputs that appear in this document may not match the output you receive when running these commands. The outputs in this document are examples only.

The following sections provide platform-specific output examples of the **show diag** command:

- [Catalyst 6000 Family Switches and Cisco 7600 Series Internet Routers with FlexWAN Module—Example Output of the show diag Command, page 4-20](#)
- [Cisco 7200 VXR Routers—Example Output of the show diag Command, page 4-21](#)
- [Cisco 7201 Router—Example Output of the show diag Command, page 4-21](#)
- [Cisco 7500 Series Routers with VIP—Example Output of the show diag Command, page 4-22](#)

Catalyst 6000 Family Switches and Cisco 7600 Series Internet Routers with FlexWAN Module—Example Output of the show diag Command

Following is an example of the **show diag** command that shows a PA-MC-STM-1 installed in a FlexWAN module:

```

Console# show diag
Slot 4: Logical_index 8
        Board is analyzed ipc ready FlexWAN controller
        HW rev 1.3, board revision B0
        Serial Number: SAD04340JY3 Part number: 73-3869-07

        Slot database information:
        Flags: 0x2004 Insertion time: 0x61BFC (04:16:29 ago)

        CWAN Controller Memory Size: Unknown

Slot 4: Logical_index 9
        Board is analyzed ipc ready FlexWAN controller
        HW rev 1.3, board revision B0
        Serial Number: SAD04340JY3 Part number: 73-3869-07

        Slot database information:
        Flags: 0x2004 Insertion time: 0x622A0 (04:16:27 ago)

        Controller Memory Size: 56 MBytes DRAM, 8192 KBytes Packet Memory
        IOS (tm) cwlc Software (cwpa-DW-M), Experimental Version 12.1(20010119:v

PA Bay 1 Information:
        Channelized OC3/STM-1 SMI PA, 1 port
        EEPROM format version 4
        HW rev 1.00, Board revision UNKNOWN
        Serial number: 00000000 Part number: 76-33356-130

```

Cisco 7200 VXR Routers—Example Output of the show diag Command

Following is an example of the **show diag** command that shows a PA-MC-STM-1 installed in port adapter slot 1 of a Cisco 7200 VXR router:

```
Router1-VXR> show diag 1
Slot 1:
  Ethernet Port adapter, 8 ports
  Port adapter is analyzed
  Port adapter insertion time 5d20h ago
  EEPROM contents at hardware discovery:
  Hardware revision 1.14          Board revision A0
  Serial number 16733712         Part number 255-65535-255
  Test history 0x0               RMA number 255-255-255
  EEPROM format version 1
  EEPROM contents (hex):
    0x20: 01 01 01 0E 00 FF 56 10 49 05 6F 08 00 00 00 00
    0x30: 50 00 00 00 00 04 29 00 FF FF FF FF FF FF FF FF
```



Note

Port adapters used with Cisco 7200 VXR routers require the correct base hardware revision in order to function. An error message occurs on bootup if the incorrect hardware revision is used. Use the **show diag** command to display the hardware revision.

Cisco 7201 Router—Example Output of the show diag Command

Following is an example of the **show diag** command from a Cisco 7201 router:

```
Router# show diag 1
Slot 1:
  Dual OC3 POS Port adapter, 2 ports
  Port adapter is analyzed
  Port adapter insertion time 00:02:19 ago
  EEPROM contents at hardware discovery:
  Hardware Revision : 1.0
  PCB Serial Number : JAE07520DYL
  Part Number : 73-8220-02
  Board Revision : A0
  RMA Test History : 00
  RMA Number : 0-0-0-0
  RMA History : 00
  Deviation Number : 0
  Product (FRU) Number : PA-POS-2OC3
  Top Assy. Part Number : 800-21857-02
  EEPROM format version 4
  EEPROM contents (hex):
    0x00: 04 FF 40 03 E3 41 01 00 C1 8B 4A 41 45 30 37 35
    0x10: 32 30 44 59 4C 82 49 20 1C 02 42 41 30 03 00 81
    0x20: 00 00 00 00 04 00 88 00 00 00 00 CB 94 50 41 2D
    0x30: 50 4F 53 2D 32 4F 43 33 20 20 20 20 20 20 20 20
    0x40: 20 C0 46 03 20 00 55 61 02 FF FF FF FF FF FF FF
    0x50: FF FF FF FF FF FF FF FF FF FF FF FF FF FF FF
    0x60: FF FF FF FF FF FF FF FF FF FF FF FF FF FF FF
    0x70: FF FF FF FF FF FF FF FF FF FF FF FF FF FF FF
```

Cisco 7500 Series Routers with VIP—Example Output of the show diag Command

Following is an example of the **show diag** command that shows a PA-MC-STM-1 installed in port adapter slot 2 on a VIP4-80 in interface processor slot 0:

```
Router# show diag 2
Slot 2:
  Physical slot 2, ~physical slot 0xD, logical slot 2, CBus 0
  Microcode Status 0x4
  Master Enable, LED, WCS Loaded
  Board is analyzed
  Pending I/O Status: None
  EEPROM format version 1
  VIP4-80 RM7000 controller, HW rev 2.02, board revision B0
  Serial number: 18314858 Part number: 73-3143-02
  Test history: 0x00 RMA number: 00-00-00
  Flags: cisco 7000 board; 7500 compatible
  EEPROM contents (hex):
    0x20: 01 22 02 02 01 17 76 6A 49 0C 47 02 00 00 00 00
    0x30: 58 00 00 00 00 00 00 00 00 00 00 00 00 00 00 00

  Slot database information:
  Flags: 0x4Insertion time: 0x1DB8 (00:02:13 ago)

  Controller Memory Size: 64 MBytes DRAM, 65536 KBytes SRAM

  PA Bay 0 Information:
  Channelized OC3/STM-1 MM PA, 1 port
  EEPROM format version 4
  HW rev 1.00, Board revision 04
  Serial number: MIC043626TF Part number: 73-4762-03
```

Using the show interfaces Command

Display status information (including the physical slot and interface address) for the interfaces you specify using the **show interfaces** command.

For complete descriptions of interface subcommands and the configuration options available for the supported interfaces, refer to the publications listed in the [“Related Documentation”](#) section on page ix.



Note

The outputs that appear in this document may not match the output you receive when running these commands. The outputs in this document are examples only.

The following sections provide platform-specific output examples of the **show interfaces** command:

- [Catalyst 6000 Family Switches and Cisco 7600 Series Internet Routers with FlexWAN Module—Example Output of the show interfaces Command, page 4-23](#)
- [Cisco 7200 VXR Routers—Example Output of the show interfaces Command, page 4-23](#)
- [Cisco 7201 Router—Example Output of the show interfaces Command, page 4-24](#)
- [Cisco 7500 Series Routers with VIP—Example Output of the show interfaces Command, page 4-24](#)

Catalyst 6000 Family Switches and Cisco 7600 Series Internet Routers with FlexWAN Module—Example Output of the show interfaces Command

Following is an example of the **show interfaces** command that shows a PA-MC-STM-1 installed in a FlexWAN module:

```

Console# show interfaces
Vlan1 is up, line protocol is up
  Hardware is Cat6k RP Virtual Ethernet
    MTU 1500 bytes, BW 1000000 Kbit, DLY 10 usec,
      reliability 255/255, txload 1/255, rxload 1/255
  Encapsulation ARPA, loopback not set
  ARP type: ARPA, ARP Timeout 04:00:00
  Last input 00:00:00, output never, output hang never
  Last clearing of "show interface" counters never
  Queueing strategy: fifo
  Output queue 0/40, 0 drops; input queue 0/75, 0 drops
  5 minute input rate 0 bits/sec, 2 packets/sec
  5 minute output rate 0 bits/sec, 0 packets/sec
    30459 packets input, 2875285 bytes, 0 no buffer
    Received 30419 broadcasts, 0 runts, 0 giants, 0 throttles
    0 input errors, 0 CRC, 0 frame, 0 overrun, 0 ignored
    343 packets output, 110047 bytes, 0 underruns
    0 output errors, 1 interface resets
    0 output buffer failures, 0 output buffers swapped out

```

Cisco 7200 VXR Routers—Example Output of the show interfaces Command

Following is an example of the **show interfaces serial** command that shows all of the information specific to interface port 0 on a PA-MC-STM-1 installed in port adapter slot 1 of a Cisco 7200 VXR router:

```

Router1-VXR> show interfaces serial 1/0.1/1/1:0
Serial1/0.1/1/1:0 is up, line protocol is up
  Hardware is Channelized STM-1 controller
    MTU 1500 bytes, BW 1984 Kbit, DLY 20000 usec,
      reliability 255/255, txload 1/255, rxload 1/255
  Encapsulation HDLC, crc 16, loopback not set
  Keepalive set (10 sec)
  Last input 00:00:01, output 00:00:06, output hang never
  Last clearing of "show interface" counters never
  Input queue: 0/75/0/0 (size/max/drops/flushes); Total output drops: 0
  Queueing strategy: weighted fair
  Output queue: 0/1000/64/0 (size/max total/threshold/drops)
    Conversations 0/1/16 (active/max active/max total)
    Reserved Conversations 0/0 (allocated/max allocated)
  5 minute input rate 0 bits/sec, 0 packets/sec
  5 minute output rate 0 bits/sec, 0 packets/sec
    50594 packets input, 1216008 bytes, 3 no buffer
    Received 0 broadcasts, 0 runts, 0 giants, 0 throttles
    223 input errors, 24 CRC, 75 frame, 0 overrun, 0 ignored, 124 abort
    59092 packets output, 6639740 bytes, 0 underruns
    0 output errors, 0 collisions, 0 interface resets
    0 output buffer failures, 0 output buffers swapped out
    0 carrier transitions no alarm present

```

Cisco 7201 Router—Example Output of the show interfaces Command

Following is an example of the **show interfaces** command for the Cisco 7201 router:

```
Router# show interfaces

GigabitEthernet0/0 is up, line protocol is up
  Hardware is MV64460 Internal MAC, address is 0019.56c5.2adb (bia
0019.56c5.2adb)
  Internet address is 209.165.200.225
  MTU 1500 bytes, BW 1000000 Kbit, DLY 10 usec,
    reliability 255/255, txload 1/255, rxload 45/255
  Encapsulation ARPA, loopback not set
  Keepalive set (10 sec)
  Full-duplex, 1000Mb/s, media type is RJ45
  output flow-control is XON, input flow-control is XON
  ARP type: ARPA, ARP Timeout 04:00:00
  Last input 00:07:03, output 00:00:07, output hang never
  Last clearing of "show interface" counters 00:00:04
  Input queue: 0/75/0/0 (size/max/drops/flushes); Total output drops: 0
  Queueing strategy: fifo
  Output queue: 0/40 (size/max)
  5 minute input rate 180240000 bits/sec, 430965 packets/sec
  5 minute output rate 0 bits/sec, 0 packets/sec
    2222975 packets input, 133378500 bytes, 0 no buffer
    Received 0 broadcasts, 0 runts, 0 giants, 0 throttles
    0 input errors, 0 CRC, 0 frame, 0 overrun, 0 ignored
    0 watchdog, 0 multicast, 0 pause input
    0 input packets with dribble condition detected
    0 packets output, 0 bytes, 0 underruns
    0 output errors, 0 collisions, 0 interface resets
    0 babbles, 0 late collision, 0 deferred
    0 lost carrier, 0 no carrier, 0 pause output
    0 output buffer failures, 0 output buffers swapped out
```

Cisco 7500 Series Routers with VIP—Example Output of the show interfaces Command

Following is an example of the **show interfaces serial** command used with a VIP. In this example, the PA-MC-STM-1 is installed in port adapter slot 0 of a VIP in interface processor slot 2.

```
Router# show interfaces serial 2/0/0.1/1/1/1:1

Serial2/0/0.1/1/1/1:1 is up, line protocol is up
  Hardware is cyBus Channelized OC3/STM-1 PA
  Internet address is 105.105.105.1/24
  MTU 1500 bytes, BW 1984 Kbit, DLY 20000 usec, rely 255/255, load 36/255
  Encapsulation HDLC, loopback not set
  Keepalive not set
  Last input 00:00:00, output 00:00:00, output hang never
  Last clearing of "show interface" counters never
  Input queue: 1/75/0 (size/max/drops); Total output drops: 0
  Queueing strategy: weighted fair
  Output queue: 0/1000/64/0 (size/max total/threshold/drops)
  Conversations 0/1/256 (active/max active/max total)
  Reserved Conversations 0/0 (allocated/max allocated)
  5 minute input rate 286000 bits/sec, 36 packets/sec
  5 minute output rate 284000 bits/sec, 36 packets/sec
    8019 packets input, 11695347 bytes, 0 no buffer
    Received 0 broadcasts, 0 runts, 0 giants, 0 throttles
    0 input errors, 0 CRC, 0 frame, 0 overrun, 0 ignored, 0 abort
    7991 packets output, 11650799 bytes, 0 underruns
    0 output errors, 0 collisions, 0 interface resets
```

```
0 output buffer failures, 0 output buffers swapped out
2 carrier transitions no alarm present
Timeslot(s) Used:1-31, Transmitter delay is 0 flags, transmit queue length 6
[Additional display text for remaining interfaces omitted]
```

Proceed to the next section, “[Using the ping Command to Verify Network Connectivity](#),” to check network connectivity of the PA-MC-STM-1 and switch or router.

Using the ping Command to Verify Network Connectivity

Using the **ping** command, you can verify that an interface port is functioning properly. This section provides a brief description of this command. Refer to the publications listed in the “[Related Documentation](#)” section on page ix for detailed command descriptions and examples.

The **ping** command sends echo request packets out to a remote device at an IP address that you specify. After sending an echo request, the system waits a specified time for the remote device to reply. Each echo reply is displayed as an exclamation point (!) on the console terminal; each request that is not returned before the specified timeout is displayed as a period (.). A series of exclamation points (!!!!!) indicates a good connection; a series of periods (.....) or the messages [timed out] or [failed] indicate a bad connection.

Following is an example of a successful **ping** command to a remote server with the address 10.0.0.10:

```
Router# ping 10.0.0.10 <Return>
Type escape sequence to abort.
Sending 5, 100-byte ICMP Echoes to 10.0.0.10, timeout is 2 seconds:
!!!!!
Success rate is 100 percent (5/5), round-trip min/avg/max = 1/15/64 ms
Router#
```

If the connection fails, verify that you have the correct IP address for the destination and that the device is active (powered on), and repeat the **ping** command.

Proceed to the next section, “[Using loopback Commands](#),” to finish checking network connectivity.

Using loopback Commands

With the loopback test, you can detect and isolate equipment malfunctions by testing the connection between the PA-MC-STM-1 interface and a remote device such as a multiplexer interface. The **loopback** subcommand places an interface in loopback mode, which enables test packets that are generated from the **ping** command to loop through a remote device. If the packets complete the loop, the connection is good. If not, you can isolate a fault to the remote device in the path of the loopback test.

The PA-MC-STM-1 supports two loopback modes at the sonet controller level: local and network.

Use the **loopback {local | network}** command to set the loopback mode, as shown below:

```
Router(config)# controller sonet 1/1/0
Router(config-controller)# loopback network
```

When the **loopback local** command is used, all data transmitted to the network is internally looped back to the receiver. In this loopback mode, the serial interfaces should go into up/up looped state.

When the **loopback network** command is used, all data received from the connected device is transmitted back unchanged. In this loopback mode, T1 serial interfaces are not working.

The PA-MC-STM-1 also supports loopback on E1 lines mapped to a TUG-3 or AU-3.

To specify a loopback on an E1 line that has been mapped to a TUG-3, use the **tug-2 e1 loopback** command in configuration controller tug3 mode.

To specify a loopback on an E1 line that has been mapped to an AU-3, use the **tug-2 e1 loopback** command in configuration controller au3 mode.

The complete **tug-2 e1 loopback** command syntax is:

```
tug-2 tug-2 number e1 e1-number loopback {local | network {line | payload}}
```

To disable the loopback, use the **no** form of this command:

```
[no] tug-2 tug-2 number e1 e1-number loopback {local | network {line | payload}}
```