



Overview

This chapter describes the PA-F half-duplex FDDI port adapters and contains the following sections:

- [Port Adapter Overview, page 1-1](#)
- [FDDI Overview, page 1-2](#)
- [FDDI Specifications, page 1-4](#)
- [LEDs, page 1-6](#)
- [Cables and Connections, page 1-7](#)
- [Port Adapter Locations on the Supported Platforms, page 1-8](#)
- [Identifying Interface Addresses, page 1-11](#)

Port Adapter Overview

The PA-F, shown in [Figure 1-1](#) and [Figure 1-2](#), provides a half-duplex FDDI connection for both single-mode and multimode fiber-optic cable. The two physical ports (PHY A and PHY B) are available with either single-mode (SC-type) or multimode media interface connector (MIC) receptacles. Each FDDI connection allows a maximum bandwidth of 100 Mbps per the FDDI standard.

The following FDDI port adapter combinations are available:

- PA-F-MM—FDDI PHY-A multimode, PHY-B multimode port adapter with optical bypass switch capability
- PA-F-SM—FDDI PHY-A single-mode, PHY-B single-mode port adapter with optical bypass switch capability

Figure 1-1 PA-F-MM Faceplate

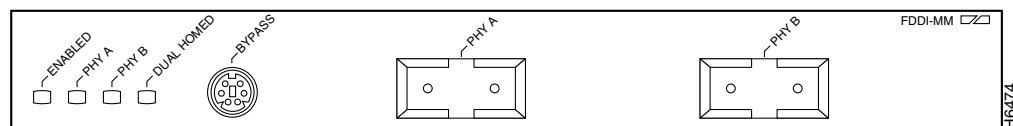
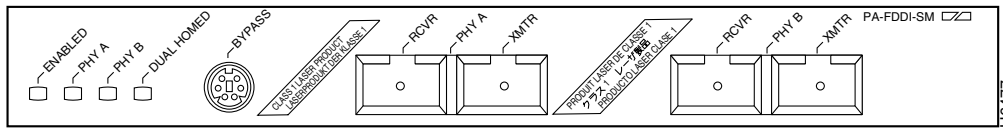

Figure 1-2 PA-F-SM Faceplate



Warning

Invisible laser radiation may be emitted from the aperture ports of the single-mode FDDI products when no fiber cable is connected. **Avoid exposure and do not stare into open apertures.**

FDDI Overview

FDDI, which specifies a 100-Mbps wire-speed token-passing dual-ring network using fiber-optic transmission media, is defined by the ANSI X3.1 standard and by ISO 9314, the international version of the ANSI standard. An FDDI network comprises two token-passing fiber-optic rings: a primary ring and a secondary ring.

A *ring* consists of two or more point-to-point connections between adjacent stations. On most networks, the primary ring is used for data communication, and the secondary ring is used as a backup. Single attachment stations attach to one ring and are typically attached through a concentrator; Class A dual attachment stations (DASs), attach to both rings.

Figure 1-3 shows a typical FDDI configuration with both dual-attached and single-attached connections. Single attachment stations (SASs) typically attach to the primary ring through a concentrator, which provides connections for multiple single-attached devices. The concentrator ensures that a failure or power down of any single attachment station does not interrupt the ring. Single attachment stations use one transmit port and one receive port to attach to the single ring. DASs (Class A) have two physical ports, designated PHY A and PHY B, each of which connects the station to both the primary and the secondary rings. Each port is a receiver for one ring and a transmitter for the other. For example, PHY A receives traffic from the primary ring and PHY B transmits to it.

Figure 1-3 Typical Configuration with DAS, Concentrator, and SASs

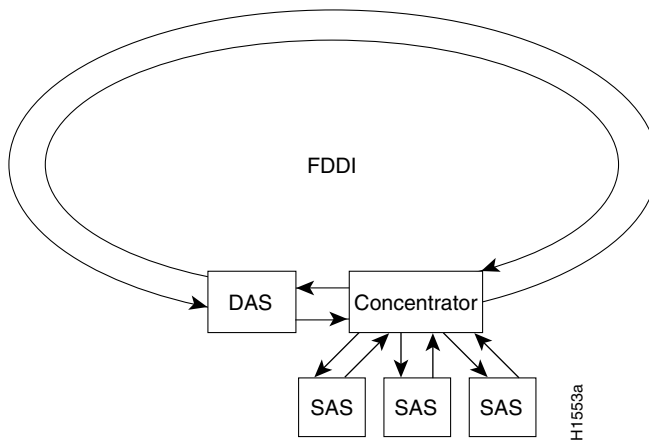

The dual rings in an FDDI network provide fault tolerance. If a station on a dual ring shuts down or fails, such as Station 3 in Figure 1-4, the ring automatically wraps (doubles back on itself) to form a single contiguous ring. This removes the failed station from the ring, but allows the other stations to continue

operation. In [Figure 1-4](#), the ring wraps to eliminate Station 3 and forms a smaller ring that includes only Stations 1, 2, and 4. A second failure could cause the ring to wrap in both directions from the point of failure, which would segment the ring into two separate rings that could not communicate with each other.

For example, if Station 1 in [Figure 1-4](#) fails after Station 3 fails, Stations 2 and 4 will each be isolated because no path for communication exists between them. Subsequent failures cause additional segmentation.

Figure 1-4 DAS Station Failure and Ring Recovery Example

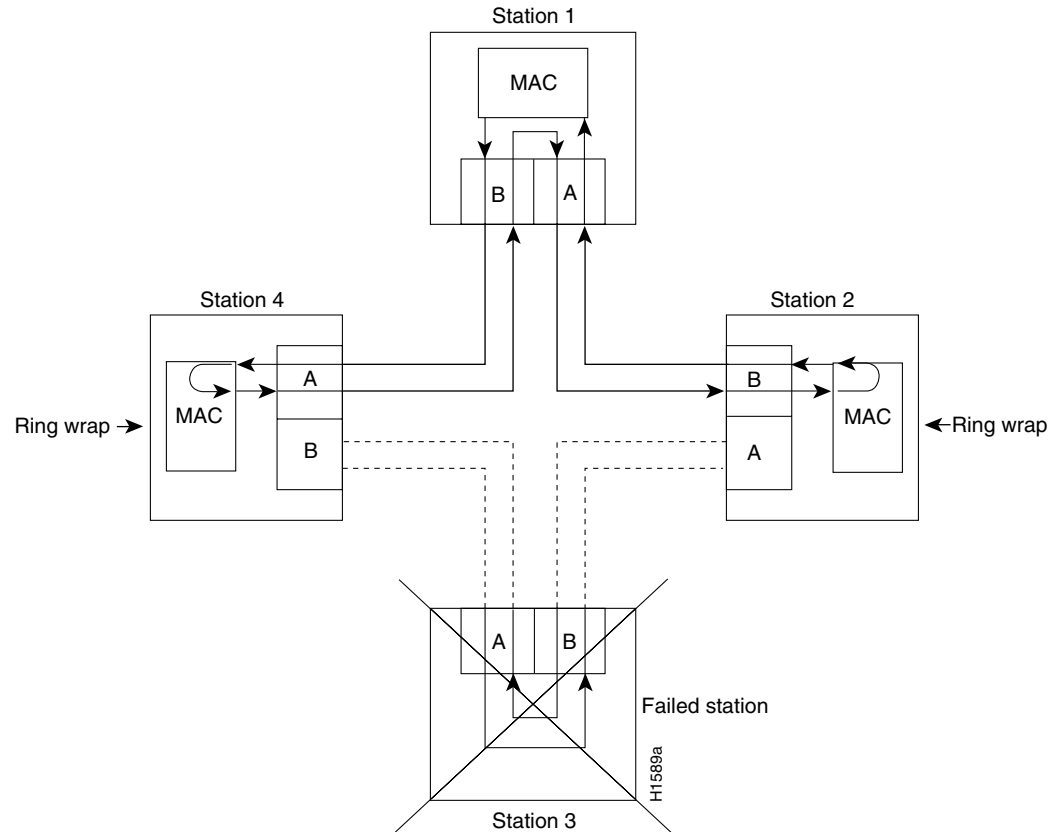

Optical Bypass Switch Overview

Optical bypass switching avoids segmentation by eliminating failed stations from a ring. An optical bypass switch allows the light signal to pass directly through it, completely bypassing the failed or shutdown station.



Note

For example, if an optical bypass switch had been installed at Station 3 in the sample ring in [Figure 1-4](#), it would have allowed the light signal to pass through the switch and maintain its existing path and direction without wrapping back on itself.

The FDDI port adapters have an optical bypass switch feature by way of a DIN connector. During normal operation, an optical bypass switch allows the light signal to pass uninterrupted directly through itself. When a station with a bypass switch fails, the bypass switch reroutes the signal back onto the ring before it reaches the failed station, so the ring does not have to wrap back on itself.

Figure 1-5 shows an optical bypass switch installed at Station 1. In the normal configuration shown on the left, Station 1 is functioning normally, so the optical bypass switch appears transparent. The switch essentially allows the signals to pass through it without interruption. However, if Station 1 fails, the optical bypass switch enables the bypassed configuration shown on the right in.

Figure 1-5 Optical Bypass Operation on a DAS

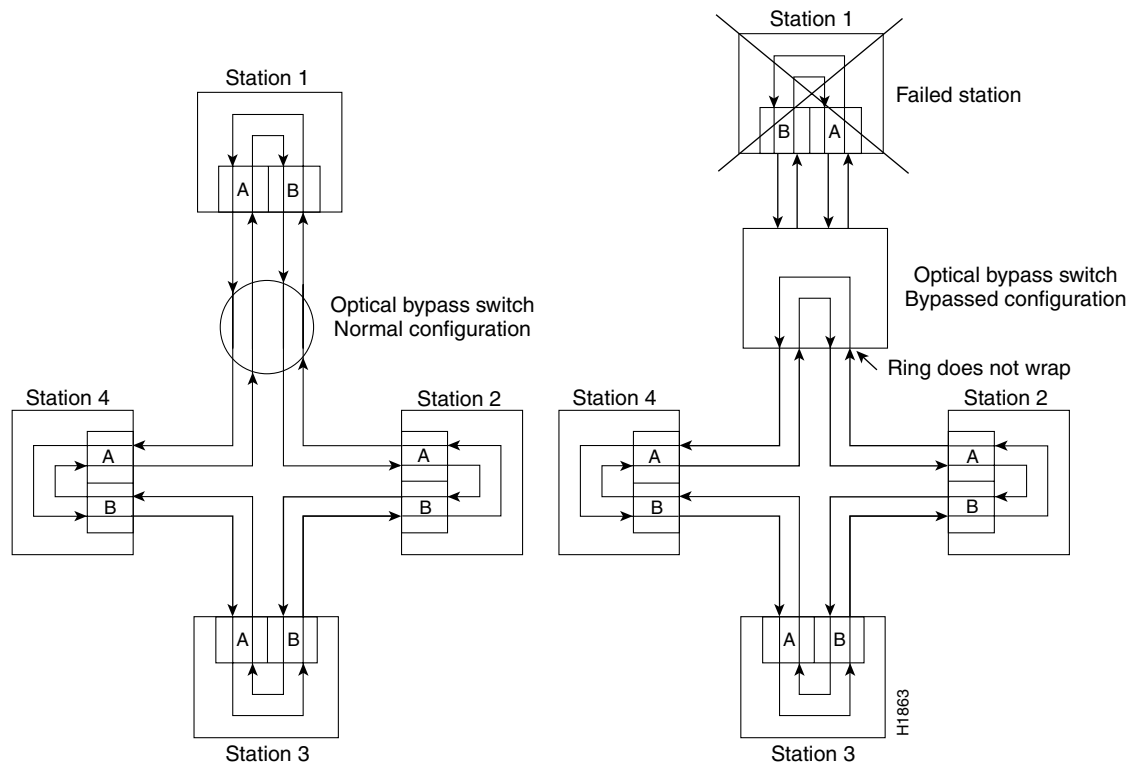

The optical bypass switch reroutes the light signal by intercepting it before it reaches failed Station 1 and sends it back out to the ring. This rerouting allows the signal to maintain its existing path and direction without wrapping back on itself. However, stations that are operating normally repeat the signal when sending it back out to the ring. Optical bypass switches do not repeat or drive the signal (they just allow the signal to pass through them), so significant signal loss can occur when the the next station on the ring is far away.

Another technique for fault tolerance is *dual homing*, in which critical devices are attached to two concentrators. Only the designated primary concentrator is active unless it (or its link) fails. If the primary concentrator does fail, the backup (passive) concentrator is automatically activated and sustains the ring.

FDDI Specifications

Typically, FDDI uses two types of fiber-optic cable:

- Single-mode (also called monomode) optical fiber with SC-type, duplex and simplex connectors
- Multimode optical fiber with media interface connectors (MICs)

Mode refers to the angle at which light rays (signals) are reflected and propagated through the optical fiber core, which acts as a waveguide for the light signals. Multimode fiber has a relatively thick core (62.5/125-micron) that reflects light rays at many angles. Single-mode fiber has a narrow core (8.7 to 10/125-micron) that allows the light to enter only at a single angle.

Although multimode fiber allows more light signals to enter at a greater variety of angles (modes), the different angles create multiple propagation paths that cause the signals to spread out in time and limit the rate at which data can be accurately received. This distortion does not occur on the single path of the single-mode signal; therefore, single-mode fiber is capable of higher bandwidth and greater cable run distances than multimode fiber. In addition, multimode transmitters usually use LEDs as a light source, and single-mode transmitters use a laser diode, which is capable of sustaining faster data rates. Both transmitter types use a photodiode detector at the receiver to translate the light signal into electrical signals.

The FDDI standard sets total fiber lengths of 1.2 miles (2 kilometers) for multimode fiber and 9.3 miles (15 kilometers) for single-mode fiber. (The maximum circumference of the FDDI network is only half the specified distance because of signal wrapping or loopback that occurs during fault correction.) The FDDI standard allows a maximum of 500 stations with a maximum distance between active stations of 1.2 miles (2 kilometers).

Table 1-1 lists the signal descriptions for the mini-DIN optical bypass switch available on the FDDI port adapters. The mini-DIN-to-DIN adapter cable (Product Number CAB-FMDD=) allows connection to an optical bypass switch with a DIN connector (which is larger than the mini-DIN connector on the FDDI port adapters).

Table 1-1 Optical Bypass Switch Pinout

Pin	Direction	Description
1	Out	+5V to secondary switch
2	Out	+5V to primary switch
3	Out	Enable optical bypass switch primary
4	Out	Enable optical bypass switch secondary
5	In	Sense optical bypass switch—1 kohm to +5V
6	Out	Ground—Sense optical bypass switch return



Note

Up to 160 milliamperes (mA) of current can be supplied to the optical bypass switch.

The FDDI port adapter implementation complies with Version 6.1 of the X3T9.5 FDDI specification, offering a Class A dual attachment interface that supports the fault-recovery methods of DAS. The FDDI port adapter supports dual homing and optical bypass and complies with ANSI X3.1 and ISO 9314 FDDI standards.

Maximum Transmission Distances for FDDI Connections

The maximum transmission distances for single-mode and multimode FDDI stations are shown in [Table 1-2](#). If the distance between two connected stations is greater than the maximum distance shown, significant signal loss can result.

Table 1-2 FDDI Maximum Transmission Distances

Transceiver Type	Maximum Distance Between Stations
Single-mode	Up to 9.3 miles (up to 15 km)
Multimode	Up to 1.2 miles (up to 2 km)

FDDI Port Adapter Optical Power Parameters

The multimode and single-mode optical fiber connections conform to the following optical power parameters:

- Output power: -19 to -14 dBm
- Input power: -31 to -14 dBm
- Input sensitivity: -31 dBm @ 2.5×10^{-10} bit error rate @ 125 Mbps

LEDs

The PA-F contains the enabled LED, which is standard on all port adapters, and status LEDs for each port. After system initialization, the enabled LED goes on to indicate that the port adapter has been enabled for operation. (The LEDs are shown in [Figure 1-6](#).) The LEDs on both the PA-F-MM and the PA-F-SM are identical to the LEDs shown in [Figure 1-6](#) and are described in [Table 1-3](#).

Figure 1-6 LEDs on the PA-F—Partial Faceplate

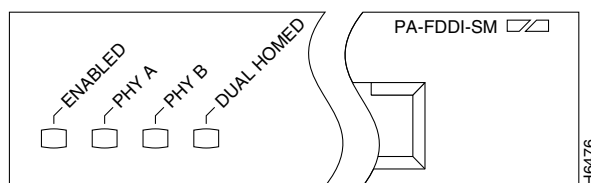

The following conditions must be met before the enabled LED goes on:

- The port adapter is correctly connected and receiving power.
- The FDDI-equipped card or chassis contains a valid microcode version that has been downloaded successfully.
- The bus recognizes the FDDI-equipped card or chassis.

If any of these conditions is not met, or if the initialization fails for other reasons, the enabled LED does not go on.

Table 1-3 PA-F LEDs

LED Label	Color	State	Indication
ENABLED	Green	On	Port adapter is enabled for operation.
PHY A	Green	On	PHY A connection is active on an FDDI ring.
PHY B	Green	On	PHY B connection is active on an FDDI ring.
DUAL HOMED	Green	On	FDDI station is dual homed.

The PA-F LED states are described in [Table 1-4](#).

Table 1-4 PA-F LED States

PHY A	PHY B	DUAL HOMED	Indications
Off	Off	Off	Not connected
Off	On	Off	Wrap B
Off	On	On	Dual homed (B connected to M port)
On	Off	Off	Wrap A
On	Off	On	Dual homing backup (A connected to M port; B port not connected)
On	On	Off	Through A

Cables and Connections

The interface receptacles on the PA-F are MICs for multimode and SC-type connectors for simplex and duplex single-mode applications. The multimode receptacle is an FDDI-standard physical sublayer (PHY) connector that encodes and decodes the data into a format acceptable for fiber transmission. The multimode receptacle accepts standard 62.5/125-micron, multimode fiber-optic cable using the MIC and, with proper cable terminators, can accept 50/125-micron fiber-optic cable. Fiber-optic cables are commercially available and are not available from Cisco Systems. Multimode uses the integrated MIC shown in [Figure 1-7](#) at both the port adapter end and the network end.

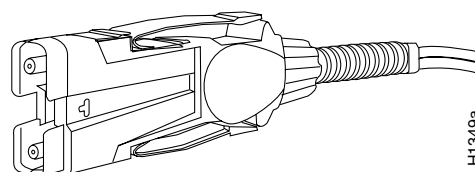
Figure 1-7 Multimode FDDI Network Interface MIC

For FDDI single-mode connections, use one duplex SC-type connector. (See [Figure 1-8](#)) or two single SC-type connectors at both the port adapter end and the network end. (See [Figure 1-9](#)). Single-mode optical fiber cable has a narrow core (8.7 to 10/125-micron) that allows light to enter only at a single angle.

Figure 1-8 Duplex SC Connector

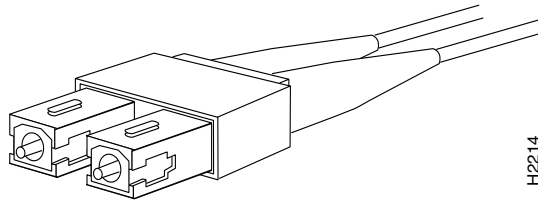
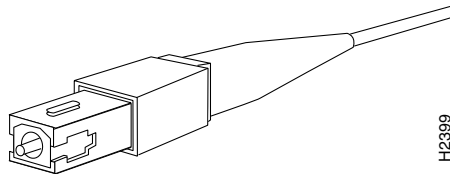

Figure 1-9 Simplex SC Connector



Warning

Invisible laser radiation may be emitted from the aperture ports of the single-mode FDDI products when no fiber cable is connected. *Avoid exposure and do not stare into open apertures.*

Port Adapter Locations on the Supported Platforms

This section discusses port adapter slot locations on the supported platforms. The illustrations that follow summarize slot location conventions on each platform.

Catalyst RSM/VIP2 Slot Numbering

The Catalyst RSM/VIP2 can be installed in any slot except the top slots, which contain the supervisor engine modules. The Catalyst RSM/VIP2 in a Catalyst 5000 family switch does not use interface processor slot numbering; therefore, slots are not numbered in [Figure 1-10](#). The *PA-F* can be installed into either port adapter slot 0 or slot 1 on a Catalyst RSM/VIP2. [Figure 1-10](#) shows a Catalyst RSM/VIP2 with two port adapters installed.



Note

The Catalyst 5500 switch has 13 slots. Slot 1 is reserved for the supervisor engine module. If a redundant supervisor engine module is used, it would go in slot 2; otherwise, slot 2 can be used for other modules. Slot 13 is a dedicated slot, reserved for the ATM Switch Processor (ASP) module. Refer to the *Catalyst 5000 Series Route Switch Module Installation and Configuration Note* for any additional slot restrictions for the Catalyst RSM/VIP2.

Figure 1-10 Catalyst 5000 Family Switch with Port Adapters Installed on Catalyst RSM/VIP2

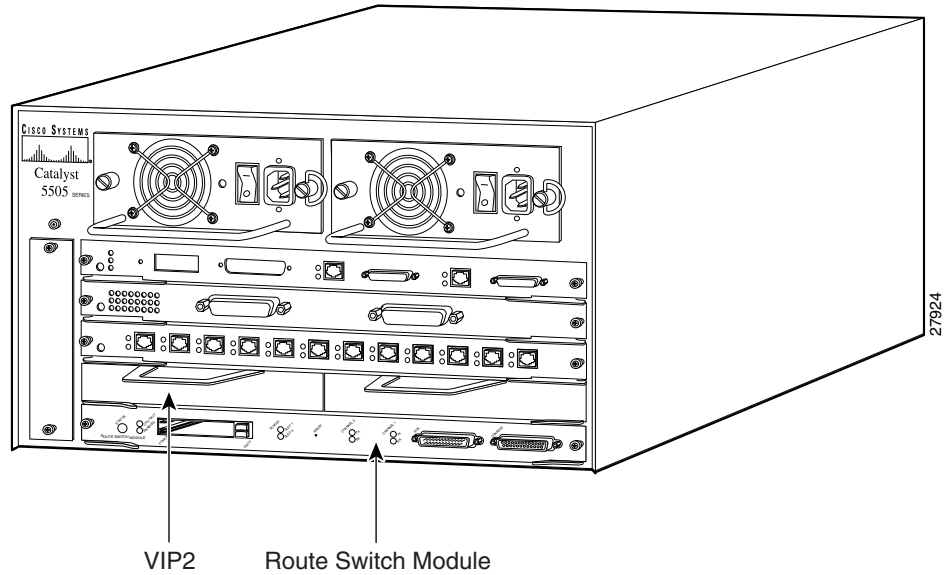

Cisco 7200 Series Routers Slot Numbering

Figure 1-11 shows a Cisco 7206 with port adapters installed. In the Cisco 7206 (including the Cisco 7206 as router shelves in a Cisco AS5800 Universal Access Server), port adapter slot 1 is in the lower left position, and port adapter slot 6 is in the upper right position. (The Cisco 7202 and Cisco 7204 are not shown; however, the PA-F can be installed in any available port adapter slot.)

Figure 1-11 Port Adapter Slots in the Cisco 7206

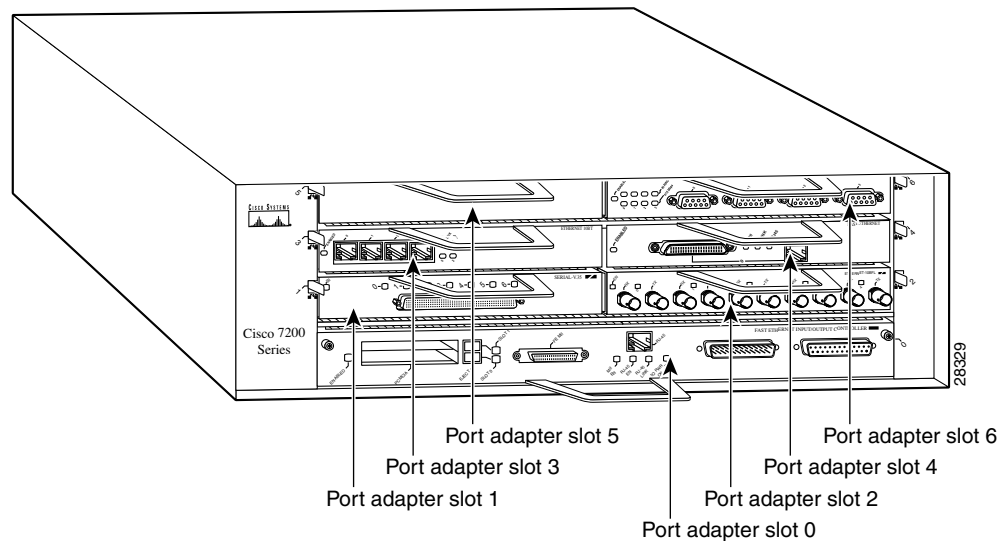

VIP2 and VIP4 Slot Numbering

Figure 1-12 shows a partial view of a VIP motherboard with installed port adapters. With the motherboard oriented as shown in Figure 1-12, the left port adapter is in port adapter slot 0, and the right port adapter is in port adapter slot 1. The slot numbering is the same for the Catalyst RSM/VIP2. The slots are always numbered 0 and 1.

Figure 1-12 VIP Motherboard with Two Port Adapters Installed—Horizontal Orientation

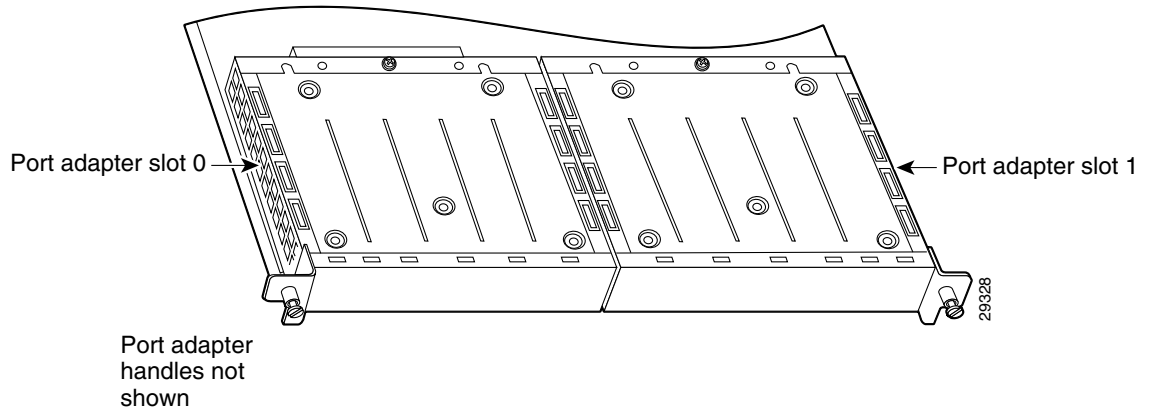

Note

In the Cisco 7000, Cisco 7507, and Cisco 7513 chassis, the VIP motherboard is installed vertically. In the Cisco 7010 and Cisco 7505 chassis, the VIP motherboard is installed horizontally.

Interface processor slots are numbered as shown in Figure 1-13.

Figure 1-13 Interface Slot Numbers—Cisco 7505 Shown

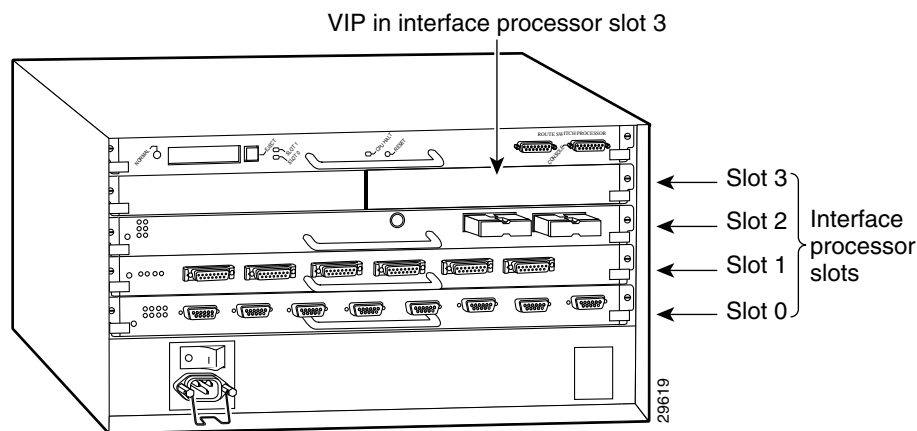

Identifying Interface Addresses

This section describes how to identify interface addresses for the PA-F in supported platforms. Interface addresses specify the actual physical location of each interface on a router or switch.

Interfaces on the PA-F installed in a router maintain the same address regardless of whether other port adapters are installed or removed. However, when you move a port adapter to a different slot, the first number in the interface address changes to reflect the new port adapter slot number.

Interfaces on a PA-F installed in a VIP2 maintain the same address regardless of whether other interface processors are installed or removed. However, when you move a VIP2 to a different slot, the interface processor slot number changes to reflect the new interface processor slot.

Note

Interface ports are numbered from left to right starting with 0.

Table 1-5 explains how to identify interface addresses.

Table 1-5 *Identifying Interface Addresses*

Platform	Interface Address Format	Numbers	Syntax
Catalyst RSM/VIP2 in Catalyst 5000 family switches	Port-adapter-slot-number/interface-port-number	Port adapter slot—always 0 or 1 Interface port—0 through 7	0/1
Cisco 7200 series and Cisco 7200 VXR routers	Port-adapter-slot-number/interface-port-number	Port adapter slot—0 through 6 (depends on the number of slots in the router) ¹ Interface port—0 through 7	1/0
VIP in Cisco 7000 series or Cisco 7500 series routers	Interface-processor-slot-number/port-adapter-slot-number/interface-port-number	Interface processor slot—0 through 12 (depends on the number of slots in the router) Port adapter slot—always 0 or 1 Interface port—0 through 7	3/1/0

1. Port adapter slot 0 is reserved for the Fast Ethernet port on the I/O controller (if present).

