



# CHAPTER 4

## Attaching the PA-GE Cables

---

To continue your PA-GE port adapter installation, you must attach the cables to the Gigabit Interface Converter (GBIC) on your port adapter.

Your PA-GE shipped with a GBIC installed, depending on the PA-GE model you ordered (1000BASE-SX, 1000BASE-LX, 1000BASE-LH, or 1000BASE-ZX).

This chapter contains the following sections:

- [Connecting Cables to the PA-GE, page 4-1](#)
- [Replacing a GBIC in the PA-GE, page 4-5](#)



Note

---

If your PA-GE arrived *without* the GBIC installed and you need to install it now, or you need to change your GBIC for another reason, use the procedures in the [“Replacing a GBIC in the PA-GE”](#) section on [page 4-5](#).

If your GBIC is installed, use the procedures in the [“Connecting Cables to the PA-GE”](#) section that follows.

---

## Connecting Cables to the PA-GE

The two cabling options for the PA-GE are discussed in the following sections:

- [Attaching Multimode and Single-Mode Optical Fiber Cables to a GBIC, page 4-2](#)

Use this cabling option for the following connections:

- PA-GE with a GBIC-SX
- PA-GE with a GBIC-LX or a GBIC-LH, when you expect transmission distances to be less than 984.25 feet (300 meters) over 50/125-micron or 62.5/125-micron multimode fiber
- PA-GE with a GBIC-ZX

(For specific information about multimode and single-mode optical fiber cables, refer to [Table 1-5](#) and the [“Optical Fiber Cables”](#) section on [page 1-9](#).)

- [Attaching a Mode Conditioning Patch Cord to a GBIC-LX or GBIC-LH, page 4-4](#)

Use this cabling option for a PA-GE with a GBIC-LX or a GBIC-LH when you expect transmission distances to be greater than 984.25 feet (300 meters) over 50/125-micron or 62.5/125-micron multimode fiber. (For specific information about the mode conditioning patch cord, see the “[Mode Conditioning Patch Cord with a Multimode GBIC-LX and GBIC-LH](#)” section on page 1-10.)

**Caution**

---

To prevent transmission problems, do not use the mode conditioning patch cord with 9/125-micron or 10/125-micron *single-mode* optical fiber under any circumstances.

---

## Attaching Multimode and Single-Mode Optical Fiber Cables to a GBIC

This section provides the cable-attachment procedure for the following connections:

- GBIC-SX with 50/125-micron or 62.5/125-micron multimode optical fiber cables
- GBIC-LX or GBIC-LH with 50/125-micron or 62.5/125-micron multimode optical fiber cables, when you expect maximum transmission distances to be less than 984.25 feet (300 meters)
- GBIC-LX with 10/125-micron single-mode optical fiber cables
- GBIC-LH with 10/125-micron single-mode optical fiber cables
- GBIC-ZX with 10/125-micron single-mode optical fiber cables

**Note**

---

Optical fiber cables are not available from Cisco Systems; they are available from outside commercial cable vendors. (For information on the proper cables to use, see [Table 1-5](#) and the “[Optical Fiber Cables](#)” section on page 1-9.)

---

Use the following procedure to attach multimode or single-mode optical fiber cables to your GBIC:

- Step 1** Attach the appropriate optical fiber cable directly to the SC-type receptacle on the GBIC. (See [Figure 4-1](#).) Use a cable with either one duplex SC-type connector or two simplex SC-type connectors.

**Figure 4-1** Attaching Multimode or Single-Mode Optical Fiber Cables to a GBIC—Horizontal Orientation Shown

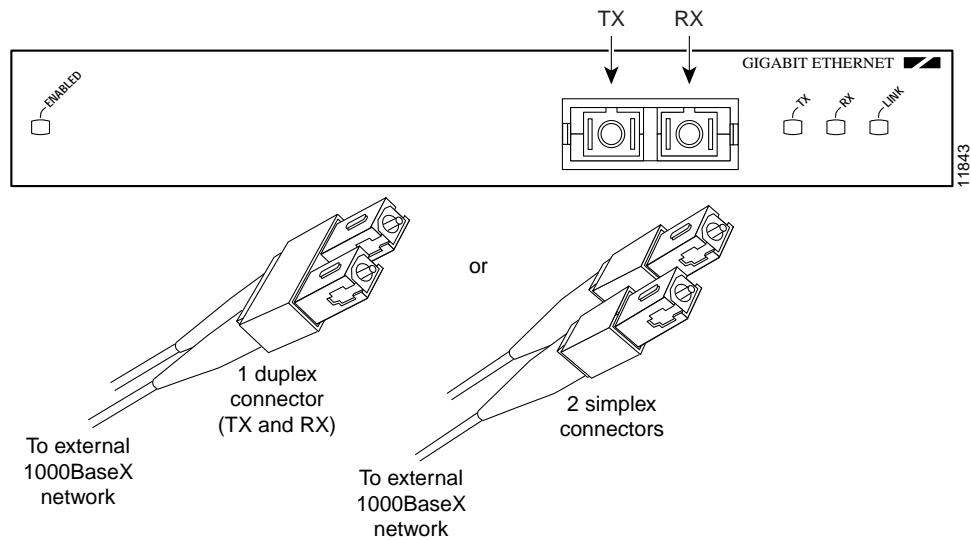

**Caution**

To prevent transmission problems, ensure that you connect the TX and RX ports on one end of the optical fiber cable to the RX and TX ports (respectively) on the other end. In other words, connect TX to RX and RX to TX.



**Warning**

**Invisible laser radiation may be emitted from disconnected fibers or connectors. Do not stare into beams or view directly with optical instruments.** Statement 105



**Warning**

**Class 1 laser product.** Statement 1008

- Step 2** Attach the network ends of your optical fiber cables to the 1000BASE-X equipment in your cable plant.

This completes the procedure for attaching optical fiber cable to your GBIC.



- Step 2** Attach the network ends of your mode conditioning patch cord to the appropriate 1000BASE-X equipment in your building cable plant. (See [Figure 4-2](#).)
- 

This completes the procedure for attaching a mode conditioning patch cord to your GBIC.

## Replacing a GBIC in the PA-GE

Your PA-GE shipped with a GBIC installed, depending on the PA-GE model you ordered (1000BASE-SX, 1000BASE-LX, 1000BASE-LH, or 1000BASE-ZX).

**Note**

If your PA-GE arrived *without* the GBIC installed and you need to install it now, or you need to change your GBIC for another reason, use the procedures in this section; otherwise, you do *not* need to use these procedures.

---

**Caution**

To prevent system problems, do not use GBICs from third-party vendors. Use only the GBIC that shipped with your PA-GE.

---

**Note**

If your GBIC is already properly installed, proceed to the “[Attaching Multimode and Single-Mode Optical Fiber Cables to a GBIC](#)” section on [page 4-2](#); otherwise, continue with the following procedures.

---

**Caution**

To prevent problems associated with data transmission, you must attach this device only to devices compliant with IEEE 802.3x specifications.

---

**Note**

You can install and remove GBICs with power on to the system; however, we strongly recommend that you do *not* install or remove the GBIC with optical fiber cables attached to it. Disconnect all cables before removing or installing a GBIC.

---

## Removing a GBIC from the PA-GE

Use the following procedure to remove a GBIC from your PA-GE:

- Step 1** Attach an ESD-preventive wrist strap between you and an unpainted chassis surface.
- Step 2** Disconnect the SC-type optical fiber cables or the mode conditioning patch cord from the GBIC; note which plug is TX and which plug is RX for reattachment.
- Step 3** Locate the tabs on either side of the exposed portion of the GBIC and squeeze them with your thumb and forefinger as you gently pull the GBIC out of the GBIC slot. (See arrows in [Figure 4-3](#).)
-

**Figure 4-3** Removing and Inserting a GBIC

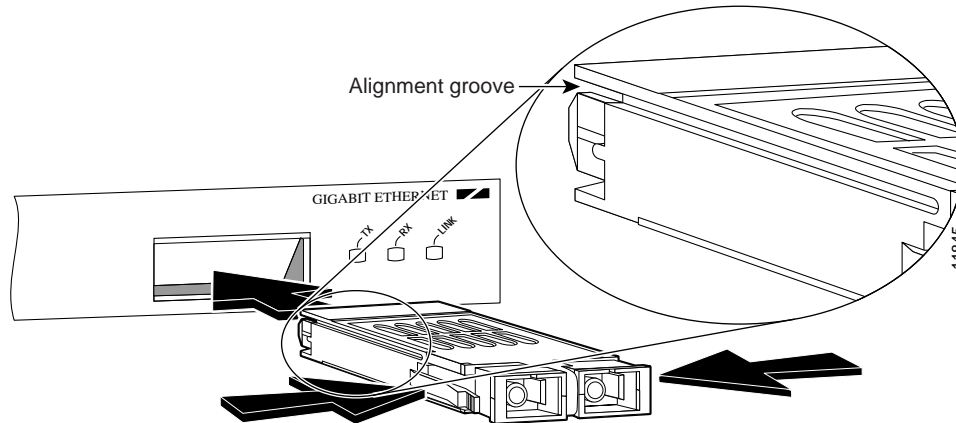

## Inserting a GBIC into the PA-GE

Use the following procedure to insert a GBIC into your PA-GE interface:

- Step 1** Attach an ESD-preventive wrist strap between you and an unpainted chassis surface.
- Step 2** Locate the alignment groove on the GBIC. (See the enlargement in [Figure 4-3](#).) Position the GBIC so that this groove is in the position shown in the enlargement, to ensure that the 20-pin plug on the GBIC is in the correct position.



**Caution**

To prevent damage to the GBIC plug and receptacle before you insert the GBIC into the GBIC slot on the PA-GE, ensure that the plug is in the orientation shown in [Figure 4-4](#).

**Figure 4-4** 20-Pin Plug on the GBIC

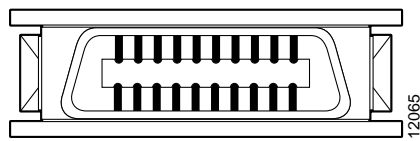

20-pin SCA-2 plug

- Step 3** Squeeze the tabs on each side of the GBIC using your thumb and forefinger, and insert the GBIC into the GBIC slot on the PA-GE. (See [Figure 4-3](#).)
- Step 4** Using moderate force, ensure that the GBIC is fully inserted into the 20-pin receptacle at the rear of the GBIC slot. The tabs on either side of the GBIC snap into place when you have completely and properly inserted the GBIC.
- Step 5** Reattach the SC-type optical fiber cable or the mode conditioning patch cord to the GBIC. (Use the appropriate procedure in the [“Connecting Cables to the PA-GE”](#) section on page 4-1.)

This completes the procedures for replacing the GBIC in your PA-GE interface.



