



PA-5EFL Ethernet 10Base-FL Port Adapter Installation and Configuration

Product Number: PA-5EFL(=)

Platforms Supported: Cisco 7100 Series Routers, Cisco 7200 Series Routers,
Cisco uBR7200 Universal Broadband Routers, Cisco 7301 Router, VIP2 in the
Cisco 7000 Series Routers and Cisco 7500 Series Routers

Corporate Headquarters
Cisco Systems, Inc.
170 West Tasman Drive
San Jose, CA 95134-1706
USA
<http://www.cisco.com>
Tel: 408 526-4000
800 553-NETS (6387)
Fax: 408 526-4100

Text Part Number: OL-3495-02



THE SPECIFICATIONS AND INFORMATION REGARDING THE PRODUCTS IN THIS MANUAL ARE SUBJECT TO CHANGE WITHOUT NOTICE. ALL STATEMENTS, INFORMATION, AND RECOMMENDATIONS IN THIS MANUAL ARE BELIEVED TO BE ACCURATE BUT ARE PRESENTED WITHOUT WARRANTY OF ANY KIND, EXPRESS OR IMPLIED. USERS MUST TAKE FULL RESPONSIBILITY FOR THEIR APPLICATION OF ANY PRODUCTS.

THE SOFTWARE LICENSE AND LIMITED WARRANTY FOR THE ACCOMPANYING PRODUCT ARE SET FORTH IN THE INFORMATION PACKET THAT SHIPPED WITH THE PRODUCT AND ARE INCORPORATED HEREIN BY THIS REFERENCE. IF YOU ARE UNABLE TO LOCATE THE SOFTWARE LICENSE OR LIMITED WARRANTY, CONTACT YOUR CISCO REPRESENTATIVE FOR A COPY.

The following information is for FCC compliance of Class A devices: This equipment has been tested and found to comply with the limits for a Class A digital device, pursuant to part 15 of the FCC rules. These limits are designed to provide reasonable protection against harmful interference when the equipment is operated in a commercial environment. This equipment generates, uses, and can radiate radio-frequency energy and, if not installed and used in accordance with the instruction manual, may cause harmful interference to radio communications. Operation of this equipment in a residential area is likely to cause harmful interference, in which case users will be required to correct the interference at their own expense.

The following information is for FCC compliance of Class B devices: The equipment described in this manual generates and may radiate radio-frequency energy. If it is not installed in accordance with Cisco's installation instructions, it may cause interference with radio and television reception. This equipment has been tested and found to comply with the limits for a Class B digital device in accordance with the specifications in part 15 of the FCC rules. These specifications are designed to provide reasonable protection against such interference in a residential installation. However, there is no guarantee that interference will not occur in a particular installation.

Modifying the equipment without Cisco's written authorization may result in the equipment no longer complying with FCC requirements for Class A or Class B digital devices. In that event, your right to use the equipment may be limited by FCC regulations, and you may be required to correct any interference to radio or television communications at your own expense.

You can determine whether your equipment is causing interference by turning it off. If the interference stops, it was probably caused by the Cisco equipment or one of its peripheral devices. If the equipment causes interference to radio or television reception, try to correct the interference by using one or more of the following measures:

- Turn the television or radio antenna until the interference stops.
- Move the equipment to one side or the other of the television or radio.
- Move the equipment farther away from the television or radio.
- Plug the equipment into an outlet that is on a different circuit from the television or radio. (That is, make certain the equipment and the television or radio are on circuits controlled by different circuit breakers or fuses.)

Modifications to this product not authorized by Cisco Systems, Inc. could void the FCC approval and negate your authority to operate the product.

The Cisco implementation of TCP header compression is an adaptation of a program developed by the University of California, Berkeley (UCB) as part of UCB's public domain version of the UNIX operating system. All rights reserved. Copyright © 1981, Regents of the University of California.

NOTWITHSTANDING ANY OTHER WARRANTY HEREIN, ALL DOCUMENT FILES AND SOFTWARE OF THESE SUPPLIERS ARE PROVIDED "AS IS" WITH ALL FAULTS. CISCO AND THE ABOVE-NAMED SUPPLIERS DISCLAIM ALL WARRANTIES, EXPRESSED OR IMPLIED, INCLUDING, WITHOUT LIMITATION, THOSE OF MERCHANTABILITY, FITNESS FOR A PARTICULAR PURPOSE AND NONINFRINGEMENT OR ARISING FROM A COURSE OF DEALING, USAGE, OR TRADE PRACTICE.

IN NO EVENT SHALL CISCO OR ITS SUPPLIERS BE LIABLE FOR ANY INDIRECT, SPECIAL, CONSEQUENTIAL, OR INCIDENTAL DAMAGES, INCLUDING, WITHOUT LIMITATION, LOST PROFITS OR LOSS OR DAMAGE TO DATA ARISING OUT OF THE USE OR INABILITY TO USE THIS MANUAL, EVEN IF CISCO OR ITS SUPPLIERS HAVE BEEN ADVISED OF THE POSSIBILITY OF SUCH DAMAGES.

CCIP, CCSP, the Cisco Arrow logo, the Cisco *Powered* Network mark, the Cisco Systems Verified logo, Cisco Unity, Follow Me Browsing, FormShare, iQ Breakthrough, iQ FastTrack, the iQ Logo, iQ Net Readiness Scorecard, Networking Academy, ScriptShare, SMARTnet, TransPath, and Voice LAN are trademarks of Cisco Systems, Inc.; Changing the Way We Work, Live, Play, and Learn, The Fastest Way to Increase Your Internet Quotient, and iQuick Study are service marks of Cisco Systems, Inc.; and Aironet, ASIST, BPX, Catalyst, CCDA, CCDP, CCIE, CCNA, CCNP, Cisco, the Cisco Certified Internetwork Expert logo, Cisco IOS, the Cisco IOS logo, Cisco Press, Cisco Systems, Cisco Systems Capital, the Cisco Systems logo, Empowering the Internet Generation, Enterprise/Solver, EtherChannel, EtherSwitch, Fast Step, GigaStack, Internet Quotient, IOS, IP/TV, iQ Expertise, LightStream, MGX, MICA, the Networkers logo, Network Registrar, *Packet*, PIX, Post-Routing, Pre-Routing, RateMUX, Registrar, SlideCast, StrataView Plus, Stratum, SwitchProbe, TeleRouter, and VCO are registered trademarks of Cisco Systems, Inc. and/or its affiliates in the U.S. and certain other countries.

All other trademarks mentioned in this document or Web site are the property of their respective owners. The use of the word partner does not imply a partnership relationship between Cisco and any other company. (0301R)

PA-5EFL Ethernet 10Base-FL Port Adapter Installation and Configuration

Copyright © 2000–2003, Cisco Systems, Inc.

All rights reserved.



Preface	v
Objectives	v
Organization	vi
Related Documentation	vi
Obtaining Documentation	viii
Cisco.com	viii
Documentation CD-ROM	viii
Ordering Documentation	viii
Documentation Feedback	ix
Obtaining Technical Assistance	ix
Cisco.com	ix
Technical Assistance Center	ix
Cisco TAC Website	x
Cisco TAC Escalation Center	x
Obtaining Additional Publications and Information	xi

Overview	1-1
Port Adapter Overview	1-1
Ethernet and Ethernet 10Base-FL Overview	1-1
IEEE 802.3 10Base-FL Specifications	1-2
LEDs	1-3
Cables and Connectors	1-4
Port Adapter Slot Locations on the Supported Platforms	1-4
Cisco 7100 Series Routers Slot Numbering	1-4
Cisco 7200 Series and Cisco uBR7200 Series Routers Slot Numbering	1-5
Cisco 7301 Router Slot Numbering	1-6
VIP Slot Numbering	1-7
Identifying Interface Addresses	1-8
Cisco 7100 Series Routers Interface Addresses	1-9
Cisco 7200 Series and Cisco uBR7200 Series Routers Interface Addresses	1-9
Cisco 7301 Router Interface Addresses	1-9
VIP2 Interface Addresses	1-9

CHAPTER 2

Preparing for Installation 2-1

- Required Tools and Equipment 2-1
- Software and Hardware Requirements 2-2
- Checking Hardware and Software Compatibility 2-3
- Safety Guidelines 2-3
 - Warning Definition 2-3
 - Electrical Equipment Guidelines 2-7
 - Telephone Wiring Guidelines 2-7
 - Preventing Electrostatic Discharge Damage 2-8
- FCC Class A Compliance 2-8

CHAPTER 3

Removing and Installing Port Adapters 3-1

- Handling Port Adapters 3-1
- Online Insertion and Removal 3-2
- Warnings and Cautions 3-3
- Port Adapter Removal and Installation 3-4
 - Cisco 7100 Series—Removing and Installing a Port Adapter 3-5
 - Cisco 7200 Series—Removing and Installing a Port Adapter 3-6
 - Cisco uBR7200 Series—Removing a Port Adapter 3-7
 - Cisco uBR7200 Series—Installing a Port Adapter 3-8
 - Cisco 7301 Router—Removing and Installing a Port Adapter 3-9
 - VIP—Removing and Installing a Port Adapter 3-10
- Connecting an ST Fiber-Optic Cable 3-11

CHAPTER 4

Configuring the PA-5EFL Port Adapter 4-1

- Using the EXEC Command Interpreter 4-1
- Configuring the Interfaces 4-2
 - Shutting Down an Interface 4-2
 - Performing a Basic Configuration 4-6
- Checking the Configuration 4-8
 - Using show Commands to Verify the New Interface Status 4-8
 - Using the show version or show hardware Commands 4-9
 - Using the show diag Command 4-12
 - Using the show interfaces Command 4-14
 - Using the ping Command to Verify Network Connectivity 4-19
 - Using loopback Commands 4-19



Preface

This preface describes the objectives and organization of this document and explains how to find additional information on related products and services. This preface contains the following sections:

- [Objectives, page v](#)
- [Organization, page vi](#)
- [Related Documentation, page vi](#)
- [Obtaining Documentation, page viii](#)
- [Obtaining Technical Assistance, page ix](#)
- [Obtaining Additional Publications and Information, page xi](#)

Objectives

This document describes how to install and configure the Cisco PA-5EFL Ethernet 10Base-FL port adapter (PA-5EFL[=]), hereafter referred to as PA-5EFL, which is used in the following platforms:

- Cisco 7100 series routers—consisting of the Cisco 7120 series and Cisco 7140 series
- Cisco 7200 series routers—consisting of the two-slot Cisco 7202, four-slot Cisco 7204 and Cisco 7204VXR, and the six-slot Cisco 7206 and the Cisco 7206VX
- Cisco uBR7200 series universal broadband routers—consisting of the six-slot Cisco uBR7246 and Cisco uBR7246VXR and the three-slot Cisco uBR7223
- Cisco 7301 router—consisting of a single slot, 1 RU router
- VIP2 in Cisco 7500 series and Cisco 7000 series routers with the Cisco 7000 series route switch processor (RSP7000) and 7000 series chassis interface (RSP7000CI)

Organization

This document is organized into the following chapters:

Section	Title	Description
Chapter 1	Overview	Describes the PA-5EFL port adapter and its LED displays, cables, and receptacles.
Chapter 2	Preparing for Installation	Describes safety considerations, tools required, and procedures you should perform before the actual installation.
Chapter 3	Removing and Installing Port Adapters	Describes the procedures for installing and removing port adapters in the supported platforms.
Chapter 4	Configuring the PA-5EFL Port Adapter	Provides instructions for configuring the PA-5EFL port adapter on the supported platforms.

Related Documentation

Your router and the Cisco IOS software running on it contain extensive features and functionality, which are documented in the following resources:

- For Cisco IOS software:

For configuration information and support, refer to the modular configuration and modular command reference publications in the Cisco IOS software configuration documentation set that corresponds to the software release installed on your Cisco hardware.



Note You can access Cisco IOS software configuration and hardware installation and maintenance documentation on the World Wide Web at <http://www.cisco.com>, <http://www-china.cisco.com>, or <http://www-europe.cisco.com>.

- Cisco 7100 series routers:
 - For hardware installation and maintenance information, refer to the *Cisco 7100 Series VPN Router Installation and Configuration Guide*.
 - For information on setting up a Virtual Private Network, refer to the *Cisco 7100 Series VPN Configuration Guide*.
- Cisco 7200 series routers:
 - For port adapter hardware and memory configuration guidelines, refer to the *Cisco 7200 Series Port Adapter Hardware Configuration Guidelines*.
 - For hardware installation and maintenance information (including the Cisco 7206 or Cisco 7206VXR as a router shelf in a Cisco AS5800 Universal Access Server), refer to the *Cisco 7200 Installation and Configuration Guide* and the hardware installation documents for the Cisco AS5800.

- Cisco 7200VXR routers:
For hardware installation and maintenance information, refer to the *Cisco 7200VXR Installation and Configuration Guide* that shipped with your Cisco 7200 VXR router.
- Cisco uBR7200 series routers:
For hardware installation and maintenance information, refer to the *Cisco uBR7200 Series Hardware Installation Guide*.
- Cisco 7301 router:
For hardware installation and maintenance information, refer to the *Cisco 7300 Series Hardware Installation and Configuration Guide*.
- VIP2 in Cisco 7000 and Cisco 7500 series routers:
For hardware installation and maintenance information, and the, refer to the following publications:
 - The installation and configuration guide that shipped with your Cisco 7000 series or Cisco 7500 series router
 - Second-Generation Versatile Interface Processor (VIP2) Installation and Configuration
- For international agency compliance, safety, and statutory information for WAN interfaces, see:
 - Site Preparation and Safety Guide
 - Regulatory Compliance and Safety Information for the Cisco 7000 Series Routers
 - Regulatory Compliance and Safety Information for the Cisco 7100 Series VPN Routers
 - Regulatory Compliance and Safety Information for the Cisco 7200 Series Routers
 - Regulatory Compliance and Safety Information for the Cisco uBR7200 Series Universal Broadband Router
 - Regulatory Compliance and Safety Information for the Cisco 7300 Series Routers
 - Regulatory Compliance and Safety Information for the Cisco 7500 Series Routers
- To view Cisco documentation or obtain general information about the documentation, refer to the following sources:
 - [“Obtaining Documentation” section on page viii](#)
 - [“Obtaining Technical Assistance” section on page ix](#)
 - Customer service at 800 553-6387 or 408 526-7208. Customer service hours are 5:00 a.m. to 6:00 p.m. Pacific time, Monday through Friday (excluding Cisco-observed holidays). You can also send e-mail to cs-rep@cisco.com.
 - *Cisco Information Packet* that shipped with your router or switch.

Obtaining Documentation

Cisco provides several ways to obtain documentation, technical assistance, and other technical resources. These sections explain how to obtain technical information from Cisco Systems.

Cisco.com

You can access the most current Cisco documentation on the World Wide Web at this URL:

<http://www.cisco.com/univercd/home/home.htm>

You can access the Cisco website at this URL:

<http://www.cisco.com>

International Cisco web sites can be accessed from this URL:

http://www.cisco.com/public/countries_languages.shtml

Documentation CD-ROM

Cisco documentation and additional literature are available in a Cisco Documentation CD-ROM package, which may have shipped with your product. The Documentation CD-ROM is updated monthly and may be more current than printed documentation. The CD-ROM package is available as a single unit or through an annual subscription.

Registered Cisco.com users can order the Documentation CD-ROM (product number DOC-CONDOCCD=) through the online Subscription Store:

<http://www.cisco.com/go/subscription>

Ordering Documentation

You can find instructions for ordering documentation at this URL:

http://www.cisco.com/univercd/cc/td/doc/es_inpk/pdi.htm

You can order Cisco documentation in these ways:

- Registered Cisco.com users (Cisco direct customers) can order Cisco product documentation from the Networking Products MarketPlace:
<http://www.cisco.com/en/US/partner/ordering/index.shtml>
- Registered Cisco.com users can order the Documentation CD-ROM (Customer Order Number DOC-CONDOCCD=) through the online Subscription Store:
<http://www.cisco.com/go/subscription>
- Nonregistered Cisco.com users can order documentation through a local account representative by calling Cisco Systems Corporate Headquarters (California, U.S.A.) at 408 526-7208 or, elsewhere in North America, by calling 800 553-NETS (6387).

Documentation Feedback

You can submit comments electronically on Cisco.com. On the Cisco Documentation home page, click **Feedback** at the top of the page.

You can e-mail your comments to bug-doc@cisco.com.

You can submit your comments by mail by using the response card behind the front cover of your document or by writing to the following address:

Cisco Systems
Attn: Customer Document Ordering
170 West Tasman Drive
San Jose, CA 95134-9883

We appreciate your comments.

Obtaining Technical Assistance

Cisco provides Cisco.com, which includes the Cisco Technical Assistance Center (TAC) Website, as a starting point for all technical assistance. Customers and partners can obtain online documentation, troubleshooting tips, and sample configurations from the Cisco TAC website. Cisco.com registered users have complete access to the technical support resources on the Cisco TAC website, including TAC tools and utilities.

Cisco.com

Cisco.com offers a suite of interactive, networked services that let you access Cisco information, networking solutions, services, programs, and resources at any time, from anywhere in the world.

Cisco.com provides a broad range of features and services to help you with these tasks:

- Streamline business processes and improve productivity
- Resolve technical issues with online support
- Download and test software packages
- Order Cisco learning materials and merchandise
- Register for online skill assessment, training, and certification programs

To obtain customized information and service, you can self-register on Cisco.com at this URL:

<http://www.cisco.com>

Technical Assistance Center

The Cisco TAC is available to all customers who need technical assistance with a Cisco product, technology, or solution. Two levels of support are available: the Cisco TAC website and the Cisco TAC Escalation Center. The avenue of support that you choose depends on the priority of the problem and the conditions stated in service contracts, when applicable.

We categorize Cisco TAC inquiries according to urgency:

- Priority level 4 (P4)—You need information or assistance concerning Cisco product capabilities, product installation, or basic product configuration.

- Priority level 3 (P3)—Your network performance is degraded. Network functionality is noticeably impaired, but most business operations continue.
- Priority level 2 (P2)—Your production network is severely degraded, affecting significant aspects of business operations. No workaround is available.
- Priority level 1 (P1)—Your production network is down, and a critical impact to business operations will occur if service is not restored quickly. No workaround is available.

Cisco TAC Website

You can use the Cisco TAC website to resolve P3 and P4 issues yourself, saving both cost and time. The site provides around-the-clock access to online tools, knowledge bases, and software. To access the Cisco TAC website, go to this URL:

<http://www.cisco.com/tac>

All customers, partners, and resellers who have a valid Cisco service contract have complete access to the technical support resources on the Cisco TAC website. Some services on the Cisco TAC website require a Cisco.com login ID and password. If you have a valid service contract but do not have a login ID or password, go to this URL to register:

<http://tools.cisco.com/RPF/register/register.do>

If you are a Cisco.com registered user, and you cannot resolve your technical issues by using the Cisco TAC website, you can open a case online at this URL:

<http://www.cisco.com/en/US/support/index.html>

If you have Internet access, we recommend that you open P3 and P4 cases through the Cisco TAC website so that you can describe the situation in your own words and attach any necessary files.

Cisco TAC Escalation Center

The Cisco TAC Escalation Center addresses priority level 1 or priority level 2 issues. These classifications are assigned when severe network degradation significantly impacts business operations. When you contact the TAC Escalation Center with a P1 or P2 problem, a Cisco TAC engineer automatically opens a case.

To obtain a directory of toll-free Cisco TAC telephone numbers for your country, go to this URL:

<http://www.cisco.com/warp/public/687/Directory/DirTAC.shtml>

Before calling, please check with your network operations center to determine the level of Cisco support services to which your company is entitled: for example, SMARTnet, SMARTnet Onsite, or Network Supported Accounts (NSA). When you call the center, please have available your service agreement number and your product serial number.

Obtaining Additional Publications and Information

Information about Cisco products, technologies, and network solutions is available from various online and printed sources.

- The *Cisco Product Catalog* describes the networking products offered by Cisco Systems as well as ordering and customer support services. Access the *Cisco Product Catalog* at this URL:
http://www.cisco.com/en/US/products/products_catalog_links_launch.html
- Cisco Press publishes a wide range of networking publications. Cisco suggests these titles for new and experienced users: *Internetworking Terms and Acronyms Dictionary*, *Internetworking Technology Handbook*, *Internetworking Troubleshooting Guide*, and the *Internetworking Design Guide*. For current Cisco Press titles and other information, go to Cisco Press online at this URL:
<http://www.ciscopress.com>
- *Packet* magazine is the Cisco monthly periodical that provides industry professionals with the latest information about the field of networking. You can access *Packet* magazine at this URL:
http://www.cisco.com/en/US/about/ac123/ac114/about_cisco_packet_magazine.html
- *iQ Magazine* is the Cisco monthly periodical that provides business leaders and decision makers with the latest information about the networking industry. You can access *iQ Magazine* at this URL:
http://business.cisco.com/prod/tree.taf%3fasset_id=44699&public_view=true&kbns=1.html
- *Internet Protocol Journal* is a quarterly journal published by Cisco Systems for engineering professionals involved in the design, development, and operation of public and private internets and intranets. You can access the *Internet Protocol Journal* at this URL:
http://www.cisco.com/en/US/about/ac123/ac147/about_cisco_the_internet_protocol_journal.html
- Training—Cisco offers world-class networking training, with current offerings in network training listed at this URL:
http://www.cisco.com/en/US/learning/le31/learning_recommended_training_list.html



Overview

This chapter describes the Cisco PA-5EFL port adapter and contains the following sections:

- [Port Adapter Overview, page 1-1](#)
- [Ethernet and Ethernet 10Base-FL Overview, page 1-1](#)
- [IEEE 802.3 10Base-FL Specifications, page 1-2](#)
- [LEDs, page 1-3](#)
- [Cables and Connectors, page 1-4](#)
- [Port Adapter Slot Locations on the Supported Platforms, page 1-4](#)
- [Identifying Interface Addresses, page 1-8](#)

Port Adapter Overview

The PA-5EFL port adapter, shown in [Figure 1-1](#), provides up to five IEEE 802.3 Ethernet 10Base-FL interfaces for the chassis. The PA-5EFL network interfaces provide a direct connection between the high-speed bus in the router and external networks. Each Ethernet 10Base-FL interface allows a maximum bandwidth of 10 Mbps, for a maximum aggregate bandwidth of 50 Mbps, half-duplex. Each 10Base-FL interface uses two multimode ST-type receptacles for receive (RX) and transmit (TX). All five ports run at wire speed.

Figure 1-1 PA-5EFL—Faceplate View

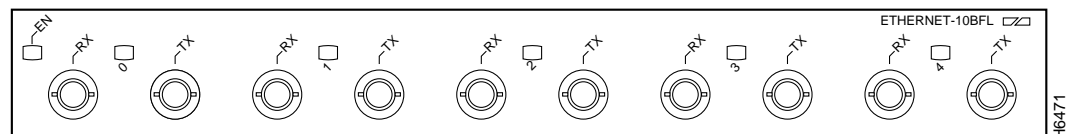

Ethernet and Ethernet 10Base-FL Overview

The term *Ethernet* is commonly used for all carrier sense multiple access/collision detection (CSMA/CD) local-area networks (LANs) that generally conform to Ethernet specifications, including IEEE 802.3. Ethernet Version 2 and IEEE 802.3 were based on, and developed shortly after, Ethernet Version 1. The slight differences between Ethernet and IEEE 802.3 are implemented in hardware, and both are supported automatically by the PA-5EFL port adapter without any hardware configuration

changes. Together, Ethernet and IEEE 802.3 are the most widely used LAN protocols. They are well suited to applications where a local communication medium must carry sporadic, occasionally heavy traffic at high-peak data rates.

The term *10Base-FL* is an abbreviation for 10 Mbps transmission, *Baseband* medium, *F* for fiber, and *L* for link, as defined in the 10Base-FL specification. The Ethernet specifications call the 5EFL device a *transceiver*, and it is connected to the station with a *transceiver cable*. The PA-5EFL is not an end station. The IEEE 802.3 specifications refer to the same type of device as a *media attachment unit* (MAU). Stations on a CSMA/CD LAN can access the network at any time. Before sending data, the station *listens* to the network to see if it is already in use. If it is, the station waits until the network is not in use, and then transmits. A collision occurs when two stations listen for network traffic, hear none, and transmit simultaneously. When this happens, both transmissions are damaged, and the stations must retransmit. The stations detect the collision and use backoff algorithms to determine when they should retransmit.

Both Ethernet and IEEE 802.3 are broadcast networks, which means that all stations see all transmissions. Each station must examine received frames to determine whether it is the intended destination and, if it is, pass the frame to a higher protocol layer for processing. IEEE 802.3 specifies several different physical layers, and Ethernet defines only one. Each IEEE 802.3 physical layer protocol has a name that summarizes its characteristics in the format *speed/signaling method/segment length* where *speed* is the LAN speed in Mbps, *signaling method* is the signaling method used (either *baseband* or *broadband*), and *segment length* is the maximum length between stations in hundreds of meters. The maximum distances for Ethernet network segments and connections depend on the type of transmission cable used; for example, fiber-optic cable (10Base-FL).

IEEE 802.3 10Base-FL Specifications

Table 1-1 summarizes the characteristics of IEEE 802.3 Ethernet and Ethernet 10Base-FL.

Table 1-1 IEEE 802.3 Ethernet and Ethernet 10Base-FL Physical Characteristics

Parameter	IEEE 802.3 Ethernet	10Base-FL Ethernet
Data rate (Mbps)	10	10
Signaling method	Baseband	Baseband
Media	50-ohm coax (thick)	Multimode optical fiber
Topology	Bus	Star

Table 1-2 lists the distance limitations for 10-Mbps transmission over multimode optical-fiber cables.

Table 1-2 Cable Distance Limitations for 10-Mbps 10Base-FL Transmission

Parameter	ST Connections
Cable specification	Multimode fiber-optic cable ¹
Maximum segment lengths	400 m (1,312 ft) for any repeater-to-DTE fiber segment 500 m (1,640 ft) with four repeaters and five segments 1000 m (3,280 ft) for any interrepeater fiber segment 2km (6,561 ft) without a repeater

1. Cisco Systems does not supply fiber-optic cables; these cables are available commercially.

Table 1-3 lists multimode optical-fiber parameters.

Table 1-3 Multimode Optical-Fiber Parameters

Parameter	Multimode
Size	62.5/125 micrometer (nominal diameter) optical fiber ¹
Attenuation	~ 3.75 dB/km, at 850 nanometers (nm)
Insertion loss	< 12.5 dB, at 850 nm
Bandwidth	> 160MHzkm, at 850 nm
Propagation delay	~ 5 microseconds/km

1. Specified in IEC Publication 793-2[14].

LEDs

The PA-5EFL port adapter has one row of five status LEDs (one for each port), and one enabled LED. (See Figure 1-2.) The green-colored LED for each port indicates port status.

Figure 1-2 LEDs on the Cisco 5EFL Port Adapter—Partial Faceplate View

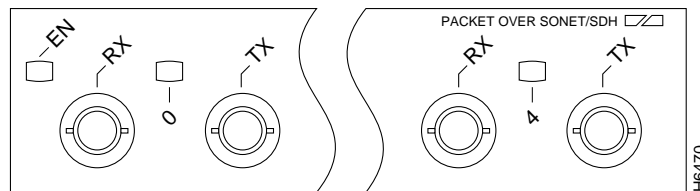

After system initialization, the enabled LED goes on to indicate that the port adapter has been enabled for operation.

The following conditions must be met before the PA-5EFL is enabled:

- The PA-5EFL is correctly connected and receiving power.
- A valid system software image for the port adapter has been downloaded successfully.
- The system recognizes the PA-5EFL or a VIP with a PA-5EFL.

If any of the above conditions are not met, or if the initialization fails for other reasons, the enabled LED does not go on.

Table 1-4 lists LED colors and indications.

Table 1-4 PA-5EFL Port Adapter LEDs

LED Label	Color	State	Meaning
ENABLED	Green	On	Port adapter is enabled for operation.
0 through 4	Green	On	Port adapter is receiving a signal from the network.

Cables and Connectors

The interface connectors on the PA-5EFL port adapter are five pairs of ST-type receptacles, designated as *RX* and *TX*. You can use all five connection pairs simultaneously or any combination of each pair individually. Each connection pair supports IEEE 802.3 and Ethernet 10Base-FL interfaces compliant with appropriate standards. [Figure 1-3](#) shows the ST fiber-optic cable plug used for *RX* and *TX* connections.

Figure 1-3 Ethernet 10Base-FL Fiber-Optic Cable Plug—ST-Type Connector

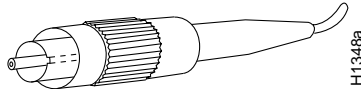

Note

The PA-5EFL interfaces on a VIP are configured for 10 Mbps, half-duplex, for a maximum aggregate bandwidth of 50 Mbps for half-duplex. Cisco Systems does not supply ST-type optical-fiber cables; these cables are available commercially. For ST-type, multimode optical-fiber cable specifications and transmission distance limitations and requirements, refer to the section “[IEEE 802.3 10Base-FL Specifications](#)” section on page 1-2.

Port Adapter Slot Locations on the Supported Platforms

This section discusses port adapter slot locations on the supported platforms. The illustrations that follow summarize slot location conventions on each platform.

Cisco 7100 Series Routers Slot Numbering

The PA-5EFL port adapter can be installed in port adapter slot 3 in Cisco 7120 series routers, and in port adapter slot 4 in Cisco 7140 series routers. [Figure 1-4](#) shows a Cisco 7120 with a port adapter installed in slot 3. [Figure 1-5](#) shows a Cisco 7140 with a port adapter installed in slot 4.

Figure 1-4 Port Adapter Slots in the Cisco 7100 Series Router—Cisco 7120 Series Router

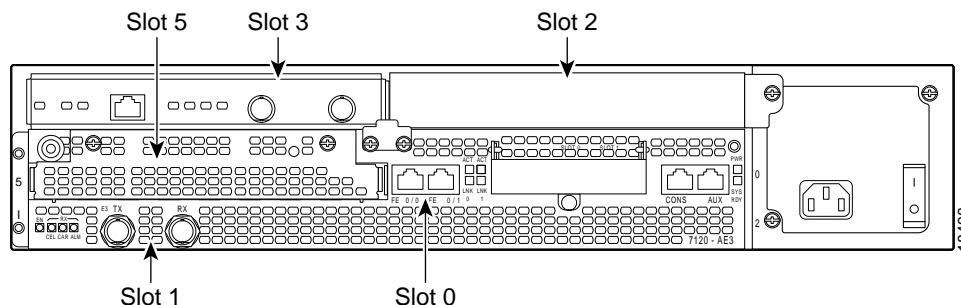
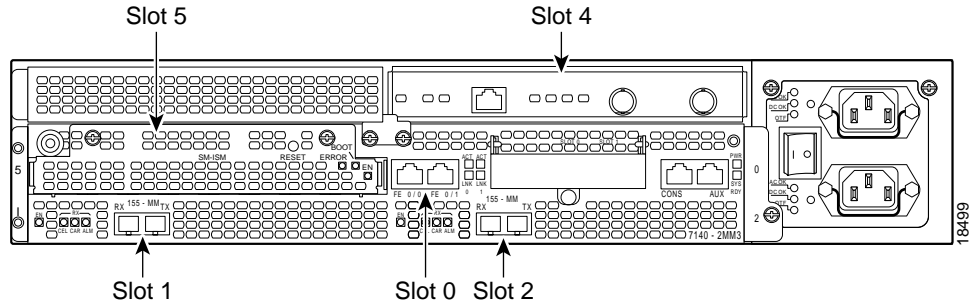

Figure 1-5 Port Adapter Slots in the Cisco 7100 Series Router—Cisco 7140 Series Router



Cisco 7200 Series and Cisco uBR7200 Series Routers Slot Numbering

Figure 1-6 shows a Cisco 7206 with port adapters installed. In the Cisco 7206 (including the Cisco 7206VXR as router shelves in a Cisco AS5800 Universal Access Server), port adapter slot 1 is in the lower left position, and port adapter slot 6 is in the upper right position. (The Cisco 7202 and Cisco 7204 are not shown; however, the PA-5EFL port adapter can be installed in any available port adapter slot.)

Figure 1-6 Port Adapter Slots in the Cisco 7206 Router

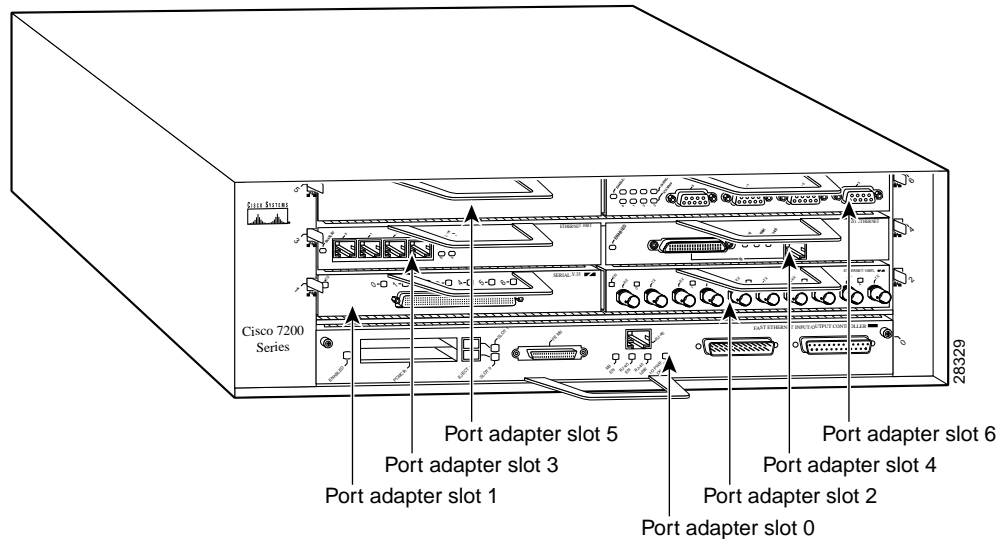
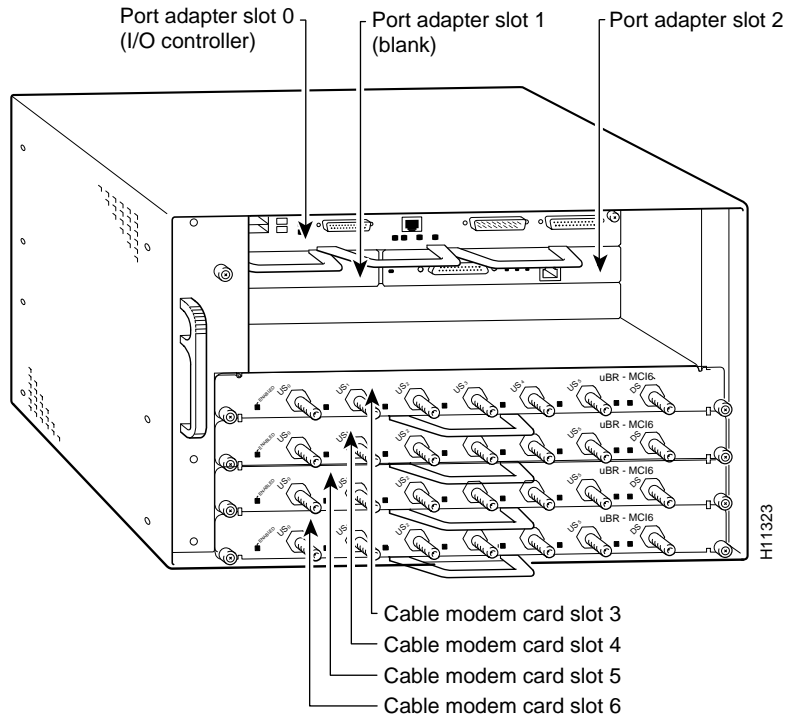

Figure 1-7 shows the slot numbering of port adapters in a Cisco uBR7246 series router. The port adapter slots are numbered slot 1 and slot 2 for the Cisco uBR7246. (Slot 0 is always reserved for the Fast Ethernet port on the I/O controller—if present.)

Figure 1-7 Port Adapter Slots in the Cisco uBR7246 Router



Cisco 7301 Router Slot Numbering

The Cisco 7301 router has one standard port adapter slot. See [Figure 1-8](#).

Figure 1-8 Port Adapter Slot in the Cisco 7301 Router

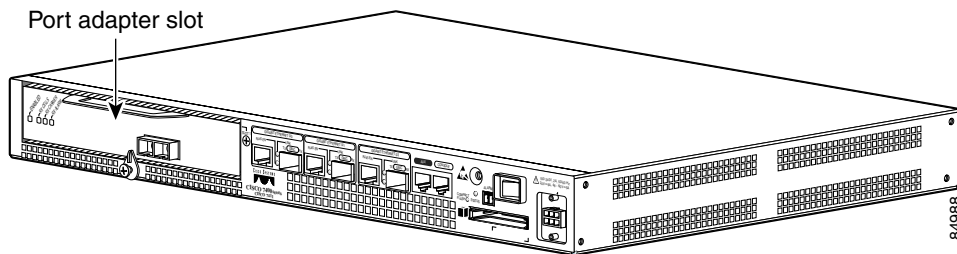

VIP Slot Numbering

Figure 1-9 shows a partial view of a VIP motherboard with installed port adapters. With the motherboard oriented as shown in Figure 1-9, the left port adapter is in port adapter slot 0, and the right port adapter is in port adapter slot 1. The slots are always numbered 0 and 1.

Figure 1-9 VIP Motherboard with Two Port Adapters Installed—Horizontal Orientation

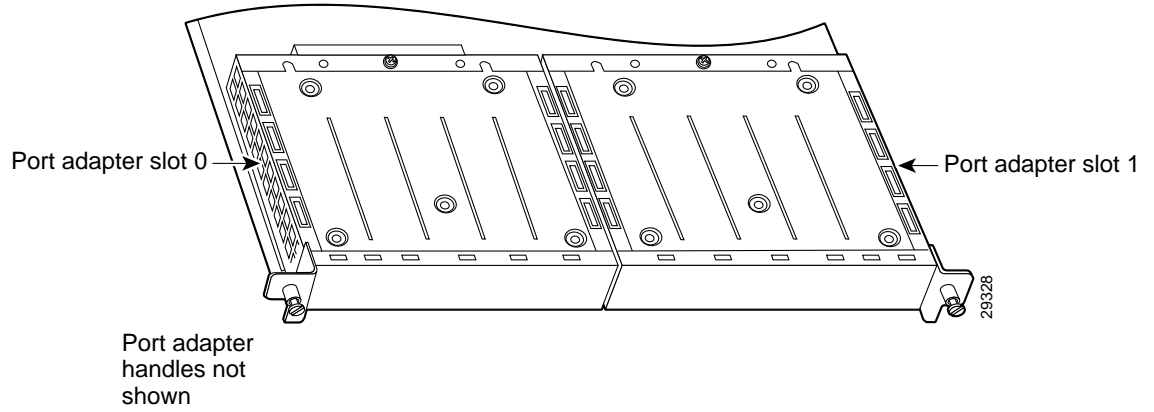

Note

In the Cisco 7000, Cisco 7507, and Cisco 7513 chassis, the VIP motherboard is installed vertically. In the Cisco 7010 and Cisco 7505 chassis, the VIP motherboard is installed horizontally.

Interface processor slots are numbered as shown in Figure 1-10.

Figure 1-10 Interface Slot Numbers—Cisco 7505 Router Shown

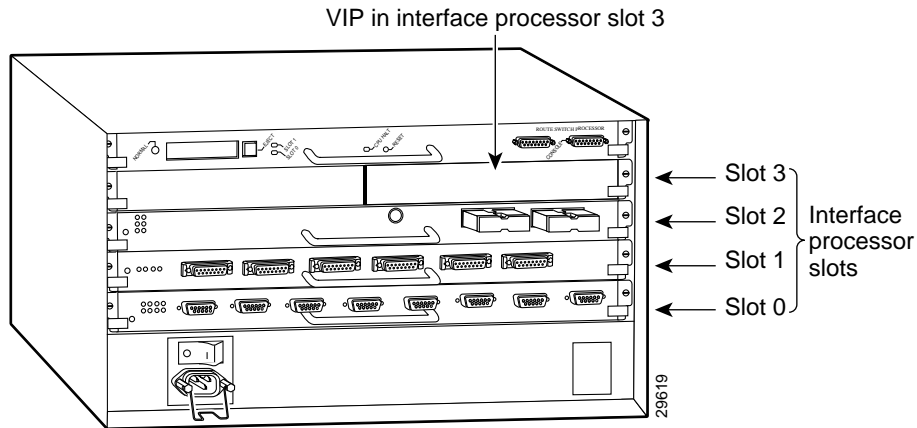

Identifying Interface Addresses

This section describes how to identify interface addresses for the PA-5EFL port adapter in supported platforms. Interface addresses specify the actual physical location of each interface on a router or switch.

Interfaces on the PA-5EFL installed in a router maintain the same address regardless of whether other port adapters are installed or removed. However, when you move a port adapter to a different slot, the first number in the interface address changes to reflect the new port adapter slot number.

Interfaces on a PA-5EFL installed in a VIP maintain the same address regardless of whether other interface processors are installed or removed. However, when you move a VIP to a different slot, the interface processor slot number changes to reflect the new interface processor slot.



Note Interface ports are numbered from left to right starting with 0.

Table 1-5 explains how to identify interface addresses.

Table 1-5 Identifying Interface Addresses

Platform	Interface Address Format	Numbers	Syntax
Cisco 7120 series routers	Port-adapter-slot-number/interface-port-number	Port adapter slot—always 3 Interface port—0 through 4	3/1
Cisco 7140 series routers	Port-adapter-slot-number/interface-port-number	Port adapter slot—always 4 Interface port—0 through 4	4/0
Cisco 7200 series routers	Port-adapter-slot-number/interface-port-number	Port adapter slot—0 through 6 (depends on the number of slots in the router) ¹ Interface port—0 through 4	1/0
Cisco uBR7246 router	Port-adapter-slot-number/interface-port-number	Port adapter slot—always 1 or 2 ¹ Interface port—0 through 4	1/2
Cisco 7301 router	Port-adapter-slot-number/interface-port-number	Port adapter slot always—1 Interface port—0 through 4	1/0
VIP in Cisco 7000 series or Cisco 7500 series routers	Interface-processor-slot-number/port-adapter-slot-number/ interface-port-number	Interface processor slot—0 through 12 (depends on the number of slots in the router) Port adapter slot—always 0 or 1 Interface port—0 through 4	3/1/0

1. Port adapter slot 0 is reserved for the Fast Ethernet port on the I/O controller (if present).

Cisco 7100 Series Routers Interface Addresses

This section describes how to identify the interface addresses used for the PA-5EFL port adapter in Cisco 7100 series routers. The interface address is composed of a two-part number in the format *port-adapter-slot-number/interface-port-number*. See [Table 1-5](#) for the interface address format.

Cisco 7200 Series and Cisco uBR7200 Series Routers Interface Addresses

This section describes how to identify the interface addresses used for the PA-5EFL port adapter in Cisco 7200 series routers or Cisco uBR7200 series routers. The interface address is composed of a two-part number in the format *port-adapter-slot-number/interface-port-number*. See [Table 1-5](#) for the interface address format.

In Cisco 7200 series routers, port adapter slots are numbered from the lower left to the upper right, beginning with port adapter slot 1 and continuing through port adapter slot 2 for the Cisco 7202, slot 4 for the Cisco 7204 and Cisco 7204VXR, and slot 6 for the Cisco 7206 and Cisco 7206VXR. (Port adapter slot 0 is reserved for the optional Fast Ethernet port on the I/O controller—if present.)

The interface addresses of the interfaces on the PA-5EFL port adapter in port adapter slot 1 are 1/0 through 1/4 (port adapter slot 1 and interfaces 0 through 4). If the PA-5EFL was in port adapter slot 4, these same interfaces would be numbered 4/0 through 4/4 (port adapter slot 4 and interfaces 0 through 4).

In the Cisco uBR7246 routers, port adapter slots are numbered slot 1 and slot 2. (Slot 0 is always reserved for the Fast Ethernet port on the I/O controller—if present.) The individual interfaces always begin with 0. The number of additional interfaces depends on the number of interface ports on a port adapter.

The interface addresses of the interfaces on a PA-5EFL port adapter in port adapter slot 2 are 2/0 through 2/4 (port adapter slot 2 and interfaces 0 through 4). If the PA-5EFL was in port adapter slot 1, these same interfaces would be numbered 1/0 through 1/4 (port adapter slot 1 and interfaces 0 through 4).

Cisco 7301 Router Interface Addresses

This section describes how to identify the interface addresses used for the PA-5EFL port adapter in Cisco 7301 router. The interface address is composed of a two-part number in the format *port-adapter-slot-number/interface-port-number*. See [Table 1-5](#) for the interface address format.

The Cisco 7301 router has a single port adapter slot (slot 1). Slot 0 through slot 4 are reserved for the interface slots. The interface addresses of the interfaces on a PA-5EFL in port adapter slot 1 are 1/0 through 1/4 (port adapter slot 1 and interfaces 0 through 4).

VIP2 Interface Addresses

This section describes how to identify the interface addresses used for the PA-5EFL port adapter on a VIP2 in Cisco 7000 and Cisco 7500 series routers.



Note

Although the processor slots in the 7-slot Cisco 7000 and Cisco 7505 and the 13-slot Cisco 7513 and Cisco 7576 are vertically oriented and those in the 5-slot Cisco 7010 and Cisco 7505 are horizontally oriented, all Cisco 7000 series and Cisco 7500 series routers use the same method for slot and port numbering.

See [Table 1-5](#) for the interface address format. The interface address is composed of a three-part number in the format *interface-processor-slot-number/port-adapter-slot-number/interface-port-number*.

If the VIP2 is inserted in interface processor slot 3, then the interface addresses of the PA-5EFL are 3/1/0 through 3/1/4 (interface processor slot 3, then the interface addresses 0 through 4). If the port adapter was in port adapter slot 0 on the VIP2, these same interface addresses would be numbered 3/0/0 through 3/0/4.

**Note**

If you remove the VIP with the PA-5EFL port adapter from interface processor slot 3 and install it in interface processor slot 2, the interface addresses become 2/1/0 through 2/1/4.



Preparing for Installation

This chapter describes the general equipment, safety, and site preparation requirements for installing the Cisco PA-5EFL port adapter. This chapter contains the following sections:

- [Required Tools and Equipment, page 2-1](#)
- [Software and Hardware Requirements, page 2-2](#)
- [Safety Guidelines, page 2-3](#)
- [FCC Class A Compliance, page 2-8](#)

Required Tools and Equipment

You need the following tools and parts to install a port adapter. If you need additional equipment, contact a service representative for ordering information.

- PA-5EFL(=)
- VIP2 (for installation in the Cisco 7000 series or Cisco 7500 series chassis only). For information about the specific VIP models that support the PA-5EFL port adapter, see the [“Software and Hardware Requirements” section on page 2-2](#).
- Cables appropriate for the port adapter interfaces (ST-type optical-fiber cables are not available from Cisco Systems; they are available from outside commercial cable vendors.)
- Number 1 Phillips and a 3/16-inch, flat-blade screwdriver (for VIP2 installation only).
- Number 2 Phillips screwdriver.
- Your own electrostatic discharge (ESD)-prevention equipment or the disposable grounding wrist strap included with all upgrade kits, field-replaceable units (FRUs), and spares.
- Antistatic mat.
- Antistatic container.

Software and Hardware Requirements

Table 2-1 lists the recommended minimum Cisco IOS software release required to use the Cisco PA-5EFL port adapter in supported router platforms.

Table 2-1 PA-5EFL Software Requirements

Router Platform	Minimum Cisco IOS Release
Cisco 7100 series <ul style="list-style-type: none"> Cisco 7120 series and Cisco 7140 series 	Cisco IOS Release 12.0(4)XE or a later release of Cisco IOS Release 11.2 P Cisco IOS Release 12.0(5)T or a later release of Cisco IOS Release 12.0 T
Cisco 7200 series^{1, 2} <ul style="list-style-type: none"> Cisco 7204VXR and Cisco 7206VXR Cisco 7204 and Cisco 7206 Cisco 7202 	Cisco IOS Release 12.0(3)T or a later release of Cisco IOS Release 12.0 T Cisco IOS Release 12.0(2)XE2 or a later release of Cisco IOS Release 12.0 XE Cisco IOS Release 12.2(4)B or a later release of Cisco IOS Release 12.2 B Cisco IOS Release 11.1(9)CA1 or a later release of Cisco IOS Release 11.1 CA Cisco IOS Release 12.2(4)B or a later release of Cisco IOS Release 12.2 B Cisco IOS Release 11.1(19)CC1 or a later release of Cisco IOS Release 11.1 CC Cisco IOS Release 11.3(4)AA or a later release of Cisco IOS Release 11.3 AA Cisco IOS Release 12.2(4)B or a later release of Cisco IOS Release 12.2 B
Cisco uBR7200 series <ul style="list-style-type: none"> Cisco uBR7246 	Cisco IOS Release 11.3(7)NA or a later release of Cisco IOS Release 11.3 NA Cisco IOS Release 12.0(3)T or a later release of Cisco IOS Release 12.0 T
Cisco 7301 router	Cisco IOS Release 12.2(11)YZ or a later release of Cisco IOS Release 12.2
VIP in Cisco 7000 series and Cisco 7500 series^{3, 4, 5} <ul style="list-style-type: none"> With VIP2-15 or VIP2-40 With VIP2-50 	Cisco IOS Release 11.1(472) or a later release of Cisco IOS Release 11.1 Cisco IOS Release 11.1(6)CA or a later release of Cisco IOS Release 11.1 CA Cisco IOS Release 11.2(1) or a later release of Cisco IOS Release 11.2 Cisco IOS Release 11.2(6)P or a later release of Cisco IOS Release 11.1 P Cisco IOS Release 11.1(14)CA or a later release of Cisco IOS Release 11.1 CA Cisco IOS Release 11.1(14)CA or a later release of Cisco IOS Release 11.1 CA

- Cisco IOS Release 11.2(7a)P or later supports half-duplex and binary synchronous communications (Bisync) operation on PA-5EFL port adapters in Cisco 7200 series routers.
- For configuration guidelines on port adapters in the Cisco 7200 series, refer to the *Cisco 7200 Series Port Adapter Hardware Configuration Guidelines*.
- The PA-5EFL can be used in the VIP in all Cisco 7500 series routers using the Route Switch Processors (RSPs), and in Cisco 7000 series routers using the RSP7000 and RSP7000CI.
- The PA-5EFL is also supported by the VIP2-15(=) and VIP2-20= models however, Cisco does not recommend its use with these VIP2 models.
- There are no restrictions to the number of installed PA-5EFL port adapters when Cisco 7000 or Cisco 7500 series routers are running Cisco IOS Release 12.2(11)YZ or later. The PA-5EFL can be installed in either port adapter slot 0 or slot 1 on the VIP.



Caution

To prevent system problems, the VIP2 requires that the Cisco 7000 series router has the RSP7000 and RSP7000CI installed. The VIP2 will *not* operate properly with the Route Processor (RP), Switch Processor (SP), or Silicon Switch Processor (SSP) installed in the Cisco 7000 series router.

Checking Hardware and Software Compatibility

To check the minimum software requirements of Cisco IOS software with the hardware installed on your router, Cisco maintains the Software Advisor tool on Cisco.com. This tool does not verify whether modules within a system are compatible, but it does provide the minimum IOS requirements for individual hardware modules or components.



Note

Access to this tool is limited to users with Cisco.com login accounts.

To access Software Advisor, click **Login** at Cisco.com and go to **Technical Support Help—Cisco TAC: Tool Index: Software Advisor**. You can also access the tool by pointing your browser directly to <http://www.cisco.com/cgi-bin/support/CompNav/Index.pl>.

Choose a product family or enter a specific product number to search for the minimum supported software release needed for your hardware.

Safety Guidelines

This section provides safety guidelines that you should follow when working with any equipment that connects to electrical power or telephone wiring.



Note

Safety warnings appear throughout this publication in procedures that, if performed incorrectly, might harm you. A warning symbol precedes each warning statement.

Warning Definition



Warning

IMPORTANT SAFETY INSTRUCTIONS

This warning symbol means danger. You are in a situation that could cause bodily injury. Before you work on any equipment, be aware of the hazards involved with electrical circuitry and be familiar with standard practices for preventing accidents. To see translations of the warnings that appear in this publication, refer to the translated safety warnings that accompanied this device.

Note: SAVE THESE INSTRUCTIONS

Note: This documentation is to be used in conjunction with the specific product installation guide that shipped with the product. Please refer to the Installation Guide, Configuration Guide, or other enclosed additional documentation for further details.

Waarschuwing BELANGRIJKE VEILIGHEIDSINSTRUCTIES

Dit waarschuwingssymbool betekent gevaar. U verkeert in een situatie die lichamelijk letsel kan veroorzaken. Voordat u aan enige apparatuur gaat werken, dient u zich bewust te zijn van de bij elektrische schakelingen betrokken risico's en dient u op de hoogte te zijn van de standaard praktijken om ongelukken te voorkomen. Voor een vertaling van de waarschuwingen die in deze publicatie verschijnen, dient u de vertaalde veiligheidswaarschuwingen te raadplegen die bij dit apparaat worden geleverd.

Opmerking **BEWAAR DEZE INSTRUCTIES.**

Opmerking Deze documentatie dient gebruikt te worden in combinatie met de installatiehandleiding voor het specifieke product die bij het product wordt geleverd. Raadpleeg de installatiehandleiding, configuratiehandleiding of andere verdere ingesloten documentatie voor meer informatie.

Varoitus TÄRKEITÄ TURVALLISUUTEEN LIITTYVIÄ OHJEITA

Tämä varoitusmerkki merkitsee vaaraa. Olet tilanteessa, joka voi johtaa ruumiinvammaan. Ennen kuin työskentelet minkään laitteiston parissa, ota selvää sähkökytkentöihin liittyvistä vaaroista ja tavanomaisista onnettomuuksien ehkäisykeinoista. Tässä asiakirjassa esitetyjen varoitusten käännökset löydät laitteen mukana toimitetuista ohjeista.

Huomautus **SÄILYTÄ NÄMÄ OHJEET**

Huomautus Tämä asiakirja on tarkoitettu käytettäväksi yhdessä tuotteen mukana tulleen asennusoppaan kanssa. Katso lisätietoja asennusoppaasta, kokoonpano-oppaasta ja muista mukana toimitetuista asiakirjoista.

Attention IMPORTANTES INFORMATIONS DE SÉCURITÉ

Ce symbole d'avertissement indique un danger. Vous vous trouvez dans une situation pouvant causer des blessures ou des dommages corporels. Avant de travailler sur un équipement, soyez conscient des dangers posés par les circuits électriques et familiarisez-vous avec les procédures couramment utilisées pour éviter les accidents. Pour prendre connaissance des traductions d'avertissements figurant dans cette publication, consultez les consignes de sécurité traduites qui accompagnent cet appareil.

Remarque **CONSERVEZ CES INFORMATIONS**

Remarque Cette documentation doit être utilisée avec le guide spécifique d'installation du produit qui accompagne ce dernier. Veuillez vous reporter au Guide d'installation, au Guide de configuration, ou à toute autre documentation jointe pour de plus amples renseignements.

Warnung WICHTIGE SICHERHEITSANWEISUNGEN

Dieses Warnsymbol bedeutet Gefahr. Sie befinden sich in einer Situation, die zu einer Körperverletzung führen könnte. Bevor Sie mit der Arbeit an irgendeinem Gerät beginnen, seien Sie sich der mit elektrischen Stromkreisen verbundenen Gefahren und der Standardpraktiken zur Vermeidung von Unfällen bewusst. Übersetzungen der in dieser Veröffentlichung enthaltenen Warnhinweise sind im Lieferumfang des Geräts enthalten.

Hinweis BEWAHREN SIE DIESE SICHERHEITSANWEISUNGEN AUF

Hinweis Dieses Handbuch ist zum Gebrauch in Verbindung mit dem Installationshandbuch für Ihr Gerät bestimmt, das dem Gerät beiliegt. Entnehmen Sie bitte alle weiteren Informationen dem Handbuch (Installations- oder Konfigurationshandbuch o. Ä.) für Ihr spezifisches Gerät.

Figyelem! FONTOS BIZTONSÁGI ELŐÍRÁSOK

Ez a figyelmeztető jel veszélyre utal. Sérülésveszélyt rejtő helyzetben van. Mielőtt bármely berendezésen munkát végezte, legyen figyelemmel az elektromos áramkörök okozta kockázatokra, és ismerkedjen meg a szokásos balesetvédelmi eljárásokkal. A kiadványban szereplő figyelmeztetések fordítása a készülékhez mellékelt biztonsági figyelmeztetések között található.

Megjegyzés ŐRIZZE MEG EZEKET AZ UTASÍTÁSOKAT!

Megjegyzés Ezt a dokumentációt a készülékhez mellékelt üzembe helyezési útmutatóval együtt kell használni. További tudnivalók a mellékelt Üzembe helyezési útmutatóban (Installation Guide), Konfigurációs útmutatóban (Configuration Guide) vagy más dokumentumban található.

Avvertenza IMPORTANTI ISTRUZIONI SULLA SICUREZZA

Questo simbolo di avvertenza indica un pericolo. La situazione potrebbe causare infortuni alle persone. Prima di intervenire su qualsiasi apparecchiatura, occorre essere al corrente dei pericoli relativi ai circuiti elettrici e conoscere le procedure standard per la prevenzione di incidenti. Per le traduzioni delle avvertenze riportate in questo documento, vedere le avvertenze di sicurezza che accompagnano questo dispositivo.

Nota CONSERVARE QUESTE ISTRUZIONI

Nota La presente documentazione va usata congiuntamente alla guida di installazione specifica spedita con il prodotto. Per maggiori informazioni, consultare la Guida all'installazione, la Guida alla configurazione o altra documentazione acclusa.

Advarsel VIKTIGE SIKKERHETSINSTRUKSJONER

Dette varselssymbolet betyr fare. Du befinner deg i en situasjon som kan forårsake personskade. Før du utfører arbeid med utstyret, bør du være oppmerksom på farene som er forbundet med elektriske kretssystemer, og du bør være kjent med vanlig praksis for å unngå ulykker. For å se oversettelser av advarslene i denne publikasjonen, se de oversatte sikkerhetsvarslene som følger med denne enheten.

Merk TA VARE PÅ DISSE INSTRUKSJONENE

Merk Denne dokumentasjonen skal brukes i forbindelse med den spesifikke installasjonsveiledningen som fulgte med produktet. Vennligst se installasjonsveiledningen, konfigureringsveiledningen eller annen vedlagt tilleggsdokumentasjon for detaljer.

Aviso INSTRUÇÕES IMPORTANTES DE SEGURANÇA

Este símbolo de aviso significa perigo. O utilizador encontra-se numa situação que poderá ser causadora de lesões corporais. Antes de iniciar a utilização de qualquer equipamento, tenha em atenção os perigos envolvidos no manuseamento de circuitos eléctricos e familiarize-se com as práticas habituais de prevenção de acidentes. Para ver traduções dos avisos incluídos nesta publicação, consulte os avisos de segurança traduzidos que acompanham este dispositivo.

Nota GUARDE ESTAS INSTRUÇÕES

Nota Esta documentação destina-se a ser utilizada em conjunto com o manual de instalação incluído com o produto específico. Consulte o manual de instalação, o manual de configuração ou outra documentação adicional inclusa, para obter mais informações.

¡Advertencia! INSTRUCCIONES IMPORTANTES DE SEGURIDAD

Este símbolo de aviso indica peligro. Existe riesgo para su integridad física. Antes de manipular cualquier equipo, considere los riesgos de la corriente eléctrica y familiarícese con los procedimientos estándar de prevención de accidentes. Vea las traducciones de las advertencias que acompañan a este dispositivo.

Nota GUARDE ESTAS INSTRUCCIONES

Nota Esta documentación está pensada para ser utilizada con la guía de instalación del producto que lo acompaña. Si necesita más detalles, consulte la Guía de instalación, la Guía de configuración o cualquier documentación adicional adjunta.

Varning! VIKTIGA SÄKERHETSANVISNINGAR

Denna varningssignal signalerar fara. Du befinner dig i en situation som kan leda till personskada. Innan du utför arbete på någon utrustning måste du vara medveten om farorna med elkretsar och känna till vanliga förfaranden för att förebygga olyckor. Se översättningarna av de varningsmeddelanden som finns i denna publikation, och se de översatta säkerhetsvarningarna som medföljer denna anordning.

OBS! SPARA DESSA ANVISNINGAR

OBS! Denna dokumentation ska användas i samband med den specifika produktinstallationshandbok som medföljde produkten. Se installationshandboken, konfigurationshandboken eller annan bifogad ytterligare dokumentation för närmare detaljer.

Предупреждение ВАЖНЫЕ СВЕДЕНИЯ ПО БЕЗОПАСНОСТИ

Этот символ предупреждает о наличии опасности. При неправильных действиях возможно получение травм. Перед началом работы с любым оборудованием необходимо ознакомиться с ситуациями, в которых возможно поражение электротоком, и со стандартными действиями для предотвращения несчастных случаев. Переведенный текст предупреждений содержится в соответствующем документе, поставляемом вместе с устройством.

СОХРАНЯЙТЕ ЭТУ ИНСТРУКЦИЮ

警告 重要安全说明

此警告标记的意思是危险。它表示您正处于可能对您造成身体伤害的环境中。在操作任何设备前，务必了解与电流电路有关的危险并熟知可防止意外事故发生的标准操作。要查看此出版物中各种警告的其它语言表述，请参阅此设备随附的已翻译过的安全警告。

请妥善保存这些说明

警告 安全上の重要な注意事項

「危険」の意味です。人身事故を予防するための注意事項が記述されています。装置の取り扱い作業を行うときは、電気回路の危険性に注意し、一般的な事故防止対策に留意してください。このマニュアルに記載されている警告の各国語版は、装置に付属の「Translated Safety Warnings」を参照してください。

これらの注意事項を保管しておいてください。

Electrical Equipment Guidelines

Follow these basic guidelines when working with any electrical equipment:

- Before beginning any procedures requiring access to the chassis interior, locate the emergency power-off switch for the room in which you are working.
- Disconnect all power and external cables before moving a chassis; do not work alone when potentially hazardous conditions exist.
- Never assume that power has been disconnected from a circuit; always check.
- Do not perform any action that creates a potential hazard to people or makes the equipment unsafe; carefully examine your work area for possible hazards such as moist floors, ungrounded power extension cables, and missing safety grounds.

Telephone Wiring Guidelines

Use the following guidelines when working with any equipment that is connected to telephone wiring or to other network cabling:

- Never install telephone wiring during a lightning storm.
- Never install telephone jacks in wet locations unless the jack is specifically designed for wet locations.
- Never touch uninsulated telephone wires or terminals unless the telephone line has been disconnected at the network interface.
- Use caution when installing or modifying telephone lines.

Preventing Electrostatic Discharge Damage

Electrostatic discharge (ESD) damage, which can occur when electronic cards or components are improperly handled, results in complete or intermittent failures. Port adapters and processor modules comprise printed circuit boards that are fixed in metal carriers. Electromagnetic interference (EMI) shielding and connectors are integral components of the carrier. Although the metal carrier helps to protect the board from ESD, use a preventive antistatic strap during handling.

Following are guidelines for preventing ESD damage:

- Always use an ESD wrist or ankle strap and ensure that it makes good skin contact.
- Connect the equipment end of the strap to an unfinished chassis surface.
- When installing a component, use any available ejector levers or captive installation screws to properly seat the bus connectors in the backplane or midplane. These devices prevent accidental removal, provide proper grounding for the system, and help to ensure that bus connectors are properly seated.
- When removing a component, use any available ejector levers or captive installation screws to release the bus connectors from the backplane or midplane.
- Handle carriers by available handles or edges only; avoid touching the printed circuit boards or connectors.
- Place a removed board component-side-up on an antistatic surface or in a static shielding container. If you plan to return the component to the factory, immediately place it in a static shielding container.
- Avoid contact between the printed circuit boards and clothing. The wrist strap only protects components from ESD voltages on the body; ESD voltages on clothing can still cause damage.
- Never attempt to remove the printed circuit board from the metal carrier.



Caution

For safety, periodically check the resistance value of the antistatic strap. The measurement should be between 1 and 10 megohms (Mohm).

FCC Class A Compliance

This equipment has been tested and found to comply with the limits for a Class A digital device, pursuant to part 15 of the FCC rules. These limits are designed to provide reasonable protection against harmful interference when the equipment is operated in a commercial environment. This equipment generates, uses, and can radiate radio-frequency energy and, if not installed and used in accordance with the instruction manual, may cause harmful interference to radio communications. Operation of this equipment in a residential area is likely to cause harmful interference, in which case users will be required to correct the interference at their own expense.

You can determine whether your equipment is causing interference by turning it off. If the interference stops, it was probably caused by the Cisco equipment or one of its peripheral devices. If the equipment causes interference to radio or television reception, try to correct the interference by using one or more of the following measures:

- Turn the television or radio antenna until the interference stops.
- Move the equipment to one side or the other of the television or radio.
- Move the equipment farther away from the television or radio.

- Plug the equipment into an outlet that is on a different circuit from the television or radio. (That is, make certain the equipment and the television or radio are on circuits controlled by different circuit breakers or fuses.)

**Note**

Note The PA-5EFL has been designed to meet these requirements. Modifications to this product that are not authorized by Cisco Systems, Inc., could void the various approvals and negate your authority to operate the product.



Removing and Installing Port Adapters

This chapter describes how to remove the Cisco PA-5EFL port adapter from supported platforms and also how to install a new or replacement port adapter. This chapter contains the following sections:

- [Handling Port Adapters, page 3-1](#)
- [Online Insertion and Removal, page 3-2](#)
- [Warnings and Cautions, page 3-3](#)
- [Port Adapter Removal and Installation, page 3-4](#)
- [Connecting an ST Fiber-Optic Cable, page 3-11](#)

Each port adapter circuit board is mounted to a metal carrier and is sensitive to electrostatic discharge (ESD) damage.



Note

When a port adapter slot is not in use, a blank port adapter must fill the empty slot to allow the router to conform to electromagnetic interference (EMI) emissions requirements and to allow proper airflow across the port adapters. If you plan to install a new port adapter in a slot that is not in use, you must first remove the blank port adapter.



Caution

When powering off the router, wait a minimum of 30 seconds before powering it on again.

Handling Port Adapters



Caution

Always handle the port adapter by the carrier edges and handle; never touch the port adapter components or connector pins. (See [Figure 3-1 on page 3-2.](#))

Figure 3-1 Handling a Port Adapter

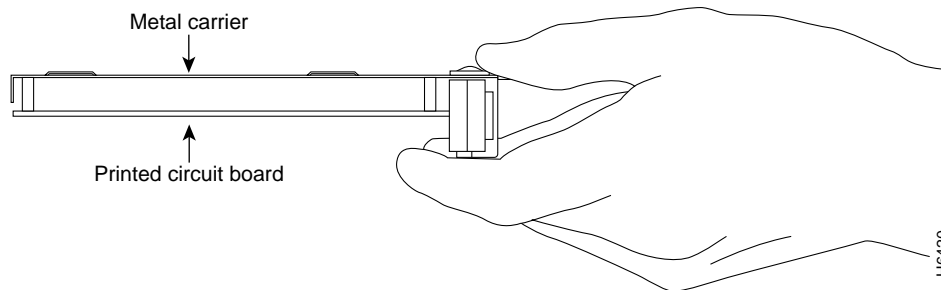

Online Insertion and Removal

Several platforms support online insertion and removal (OIR) of port adapters; therefore, you do not have to power down routers when removing and replacing a PA-5EFL port adapter on Cisco 7100 series routers, Cisco 7200 series routers, Cisco uBR7246 series routers, or the Cisco 7301 router.

Although the VIP supports online insertion and removal, individual port adapters do not. To replace port adapters, you must first remove the VIP from the chassis and then install or replace port adapters as required. If a blank port adapter is installed on the VIP in which you want to install a new port adapter, you must first remove the VIP from the chassis and then remove the blank port adapter.



Caution

To prevent system problems, do not remove port adapters from the VIP motherboard or attempt to install other port adapters on the motherboard when the system is operating. To install or replace port adapters, first remove the VIP from its interface processor slot.

It is wise to gracefully shut down the system before removing a port adapter that has active traffic moving through it. Removing a module while traffic is flowing through the ports can cause system disruption. Once the module is inserted, the ports can be brought back up.



Note

As you disengage the module from the router or switch, online insertion and removal (OIR) administratively shuts down all active interfaces in the module.

OIR allows you to install and replace modules while the router is operating; you do not need to notify the software or shut down the system power, although you should not run traffic through the module you are removing while it is being removed. OIR is a method that is seamless to end users on the network, maintains all routing information, and preserves sessions.

The following is a functional description of OIR for background information only; for specific procedures for installing and replacing a module in a supported platform, refer to the [“Port Adapter Removal and Installation”](#) section on page 3-4.

Each module has a bus connector that connects it to the router. The connector has a set of tiered pins in three lengths that send specific signals to the system as they make contact with the module. The system assesses the signals it receives and the order in which it receives them to determine if a module is being removed from or introduced to the system. From these signals, the system determines whether to reinitialize a new interface or to shut down a disconnected interface.

Specifically, when you insert a module, the longest pins make contact with the module first, and the shortest pins make contact last. The system recognizes the signals and the sequence in which it receives them.

When you remove or insert a module, the pins send signals to notify the system of changes. The router then performs the following procedure:

1. Rapidly scans the system for configuration changes.
2. Initializes newly inserted port adapters or administratively shuts down any vacant interfaces.
3. Brings all previously configured interfaces on the module back to their previously installed state. Any newly inserted interface is put in the administratively shutdown state, as if it was present (but not configured) at boot time. If a similar module type is reinserted into a slot, its ports are configured and brought online up to the port count of the originally installed module of that type.



Note

Before you begin installation, read [Chapter 2, “Preparing for Installation,”](#) for a list of parts and tools required for installation.

Warnings and Cautions

Observe the following warnings and cautions when installing or removing port adapters.



Caution

Do not slide a port adapter all the way into the slot until you have connected all required cables. Trying to do so disrupts normal operation of the router or switch.



Note

If a port adapter lever or other retaining mechanism does not move to the locked position, the port adapter is not completely seated in the midplane. Carefully pull the port adapter halfway out of the slot, reinsert it, and move the port adapter lever or other mechanism to the locked position.



Caution

To prevent jamming the carrier between the upper and lower edges of the port adapter slot, and to ensure that the edge connector at the rear of the port adapter mates with the connection at the rear of the port adapter slot, make certain that the carrier is positioned correctly, as shown in the cutaway in the following illustrations.



Caution

When performing the following procedures, wear a grounding wrist strap to avoid ESD damage to the card. Some platforms have an ESD connector for attaching the wrist strap.



Warning

Hazardous voltage or energy is present on the backplane when the system is operating. Use caution when servicing.

Port Adapter Removal and Installation

In this section, the illustrations that follow give step-by-step instructions on how to remove and install port adapters. This section contains the following illustrations:

- [Cisco 7200 Series—Removing and Installing a Port Adapter, page 3-6](#)
- [Cisco 7100 Series—Removing and Installing a Port Adapter, page 3-5](#)
- [Cisco uBR7200 Series—Removing a Port Adapter, page 3-7](#)
- [Cisco uBR7200 Series—Installing a Port Adapter, page 3-8](#)
- [Cisco 7301 Router—Removing and Installing a Port Adapter, page 3-9](#)
- [VIP—Removing and Installing a Port Adapter, page 3-10](#)

Cisco 7100 Series—Removing and Installing a Port Adapter

Step 1

To remove the port adapter, use a number 2 Phillips screwdriver to loosen the screws on the locking tab. Then slide the tab down to the unlocked position.

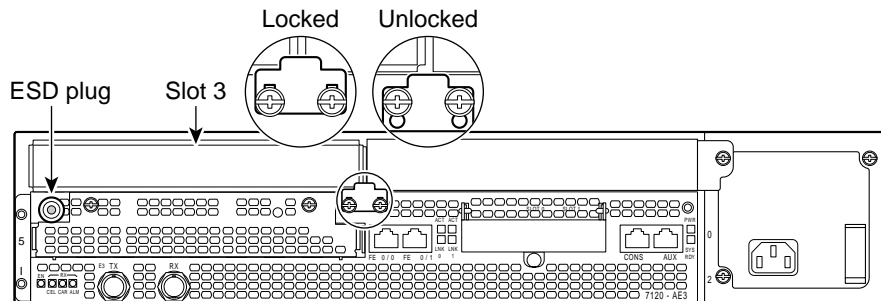

Step 2

Grasp the handle of the port adapter and pull the port adapter from the router, about halfway out of its slot. If you are removing a blank port adapter, pull the blank port adapter completely out of the chassis slot.

Step 3

With the port adapter halfway out of the slot, disconnect all cables from the port adapter.

Step 4

After disconnecting the cables, pull the port adapter from its chassis slot.

Step 5

To insert the port adapter, carefully align the port adapter carrier between the upper and the lower edges of the port adapter slot.

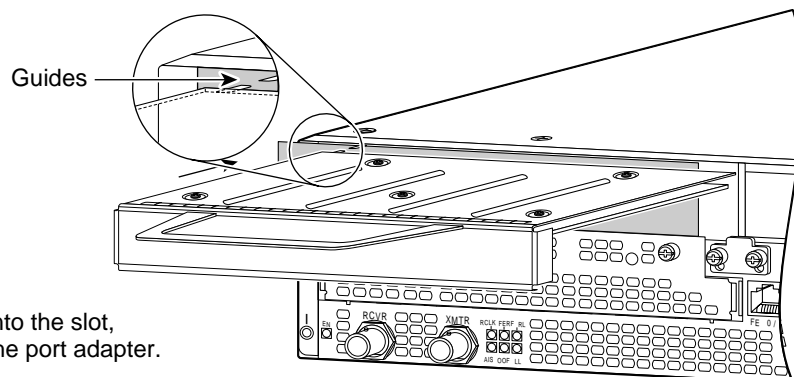

Step 6

With the port adapter halfway into the slot, connect all required cables to the port adapter.

Step 7

After connecting all required cables, carefully slide the port adapter all the way into the slot until the port adapter is seated in the router midplane.

Step 8

After the port adapter is properly seated, lock the port adapter retaining mechanism.

26522

Cisco 7200 Series—Removing and Installing a Port Adapter

Step 1

To remove the port adapter, place the port adapter lever in the unlocked position. (See A.) The port adapter lever remains in the unlocked position.

Step 2

Grasp the handle of the port adapter and pull the port adapter from the router, about halfway out of its slot. If you are removing a blank port adapter, pull the blank port adapter completely out of the chassis slot.

Step 3

With the port adapter halfway out of the slot, disconnect all cables from the port adapter. After disconnecting the cables, pull the port adapter from its chassis slot.

Step 4

To insert the port adapter, carefully align the port adapter carrier between the upper and the lower edges of the port adapter slot. (See B.)

Step 5

Carefully slide the new port adapter halfway into the port adapter slot. (See B.)

Step 6

With the port adapter halfway into the slot, connect all required cables to the port adapter. After connecting all required cables, carefully slide the port adapter all the way into the slot until the port adapter is seated in the router midplane.

Step 7

After the port adapter is properly seated, lock the port adapter lever. (See A.)

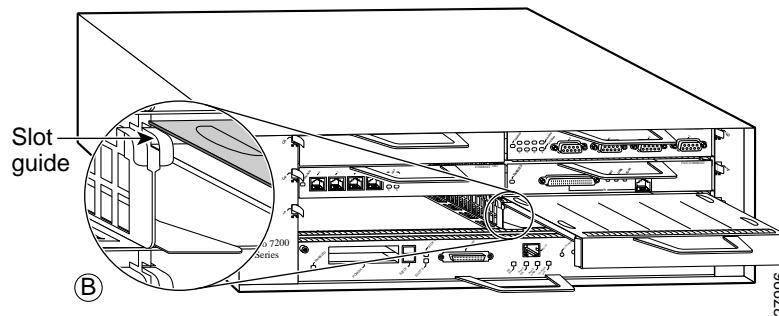
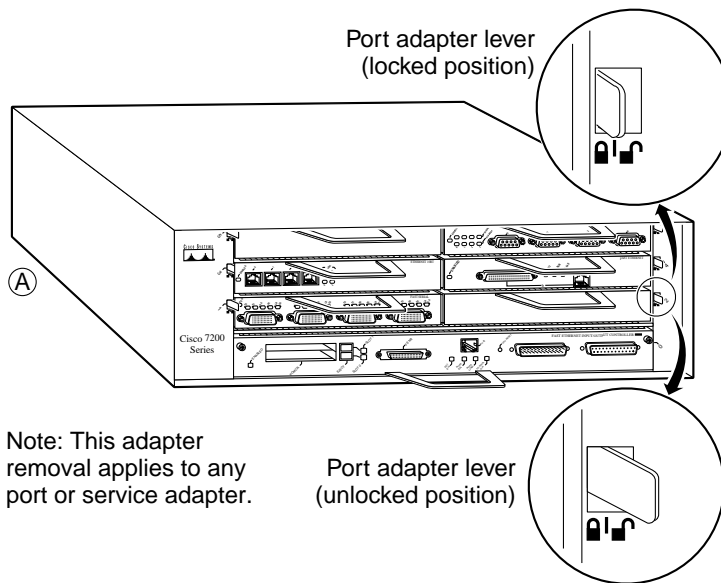

Cisco uBR7200 Series—Removing a Port Adapter

Step 1

To remove the port adapter, unlock the port adapter retaining mechanism. The port adapter lever remains in the unlocked position.

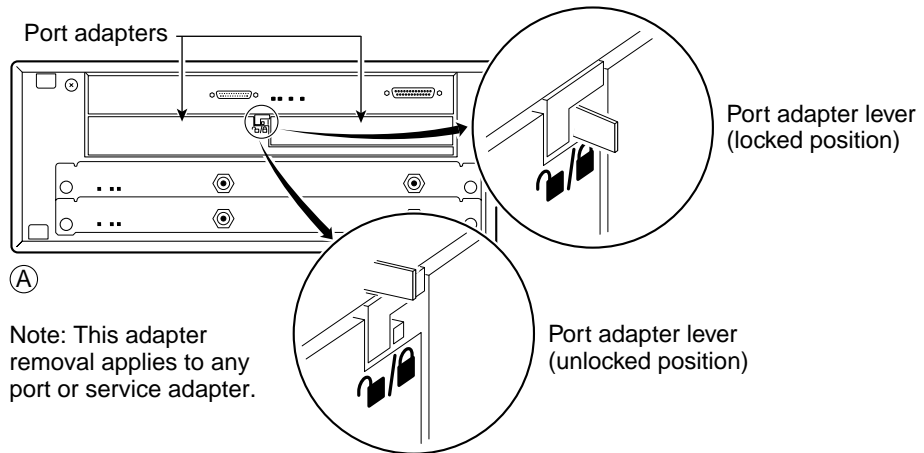

Place the port adapter lever (Cisco uBR7223, see A), or the port adapter retention clip (Cisco uBR7246 and Cisco uBR7246 VXR, see B) in the unlocked position. Either mechanism remains in the unlocked position.

Step 2

Grasp the handle of the port adapter and pull the port adapter from the router, about halfway out of its slot. If you are removing a blank port adapter, pull the blank port adapter completely out of the chassis slot.

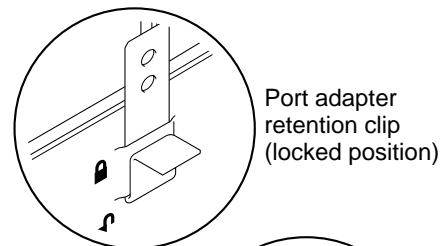

Step 3

With the port adapter halfway out of the slot, disconnect all cables from the port adapter. After disconnecting the cables, pull the port adapter from its chassis slot.

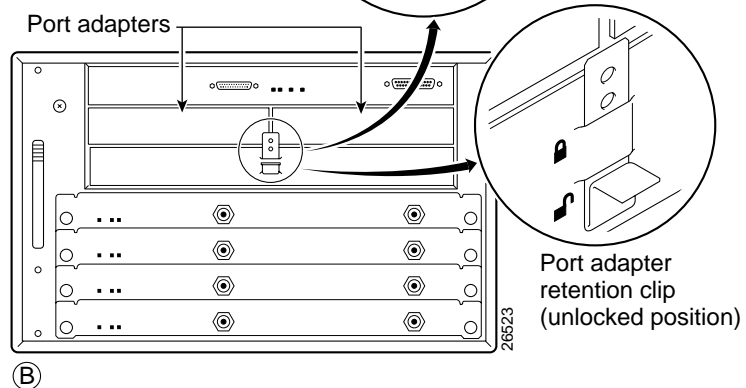

Cisco uBR7200 Series—Installing a Port Adapter

Step 1

To insert the port adapter, carefully align the port adapter carrier between the upper and the lower edges of the port adapter slot.

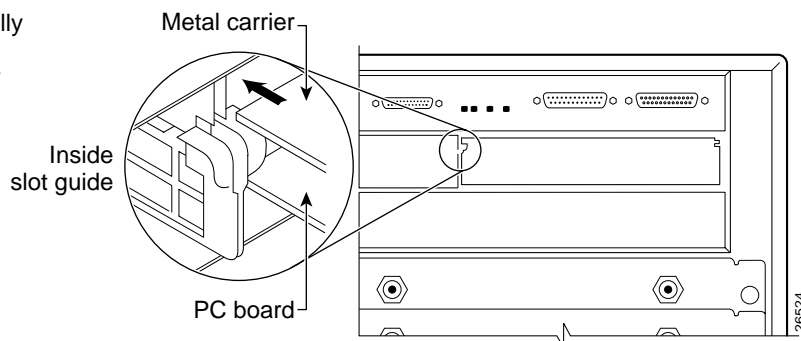

Step 2

Carefully slide the new port adapter halfway into the port adapter slot.

Step 3

With the port adapter halfway into the slot, connect all required cables to the port adapter. After connecting all required cables, carefully slide the port adapter all the way into the slot until the port adapter is seated in the router midplane.

Step 4

After the port adapter is properly seated, lock the port adapter lever or retention clip, depending on your system. (See illustration on preceding page.)

Cisco 7301 Router—Removing and Installing a Port Adapter

Step 1

Use an ESD wrist strap to ground yourself to the router.

Step 2

To remove a port adapter, use a Phillips screwdriver to turn the screw holding the port adapter latch. The screw should be loose enough to allow the latch to rotate to an unlocked position. (See A.) The latch can rotate 360°.

Step 3

Grasp the handle and pull the port adapter from the router, about halfway out of its slot. (See B.) If you are removing a blank port adapter, pull the blank port adapter completely out of the chassis slot.

Step 4

With the port adapter halfway out of the slot, disconnect all cables from the port adapter. After disconnecting the cables, pull the port adapter from its chassis slot.

Caution

The port adapter must slide into the slot guides close to the chassis lid. (See C.) Do not allow the port adapter components to come in contact with the system board or the port adapter could be damaged.

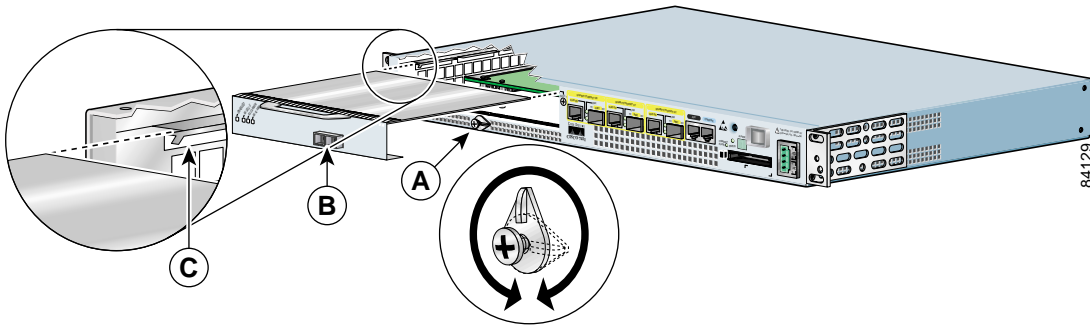

Step 5

To insert the port adapter, carefully align the port adapter carrier in the slot guides. (See C.) Slide the new port adapter halfway into the chassis.

Step 6

Connect all required cables to the port adapter. After connecting all required cables, carefully slide the port adapter all the way into the slot until the port adapter is seated in the midplane.

Step 7

After the port adapter is properly seated, turn and secure the port adapter latch in the upright, locked position. (See A.) Tighten the screw to ensure the port adapter remains firmly in place.

VIP—Removing and Installing a Port Adapter

Note: You must first remove the VIP from the chassis before removing a port adapter from the VIP.

Step 1

To remove the port adapter, remove the screw that secures the port adapter (or blank port adapter). (See A.)

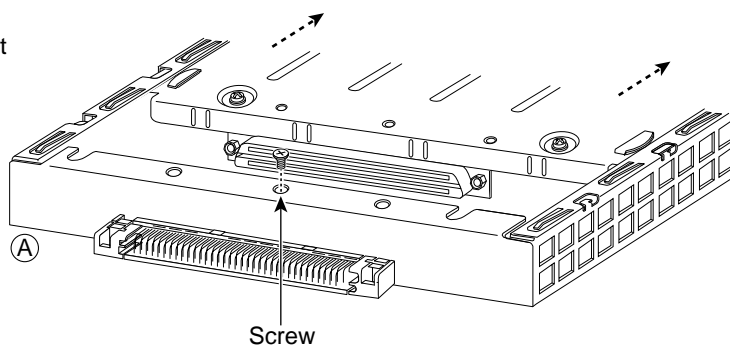

Step 2

With the screw removed, grasp the handle on the front of the port adapter (or blank port adapter) and carefully pull it out of its slot, away from the edge connector at the rear of the slot. (See A.)

Step 3

To insert the port adapter, carefully align the port adapter carrier between the upper and the lower edges of the port adapter slot. (See B.)

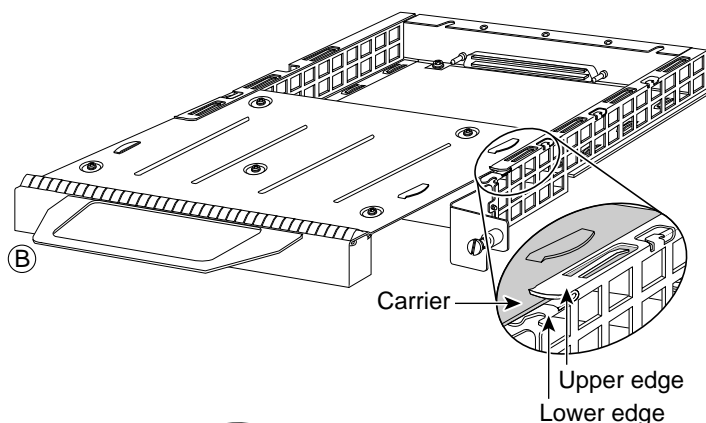

Step 4

Carefully slide the new port adapter into the port adapter slot until the connector on the port adapter is completely seated in the connector at the rear of the port adapter slot. (See B.)

Step 5

Install the screw in the rear of the port adapter slot on the VIP. Do not overtighten the screw. (See A.)

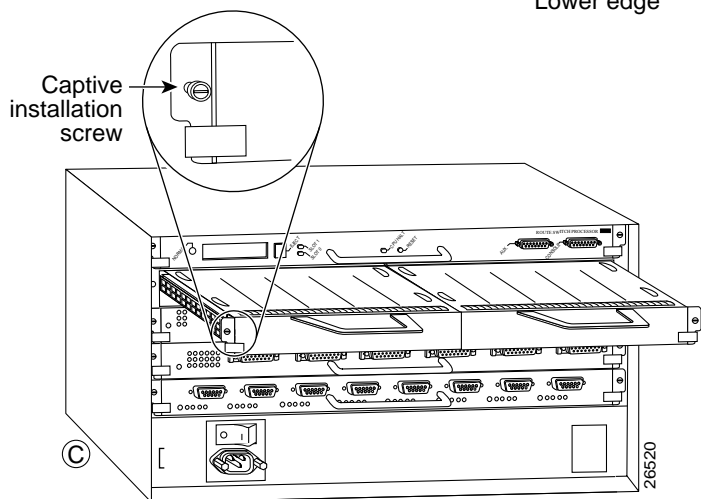

Step 6

Carefully slide the VIP motherboard into the interface processor slot until the connectors at the rear of the VIP are completely seated in the connectors at the rear of the interface processor slot. Use the ejector levers to seat the VIP in the interface processor slot. Tighten the captive installation screws on the VIP. (See C.)

Connecting an ST Fiber-Optic Cable

On a single PA-5EFL you can use up to five pairs of ST fiber-optic connections. The PA-5EFL port adapter is an end station device and not a repeater; you *must* connect the PA-5EFL to a 10Base-FL repeater or hub. ST-type fiber-optic cables are not available from Cisco Systems; they are available from outside commercial cable vendors.

Connect ST fiber-optic cables to the PA-5EFL port adapter as follows:

- Step 1** Attach the RX multimode fiber-optic cable directly to the RX port on the PA-5EFL. (See [Figure 3-2](#).)



Note Port adapters have a handle attached, but it is not shown in to allow a full view of the detail on each port adapter's faceplate.

- Step 2** Attach the TX multimode fiber-optic cable directly to the TX port on the PA-5EFL port adapter. (See [Figure 3-2](#).)

Figure 3-2 Connecting PA-5EFL Port Adapter ST Cable Pairs—Front View

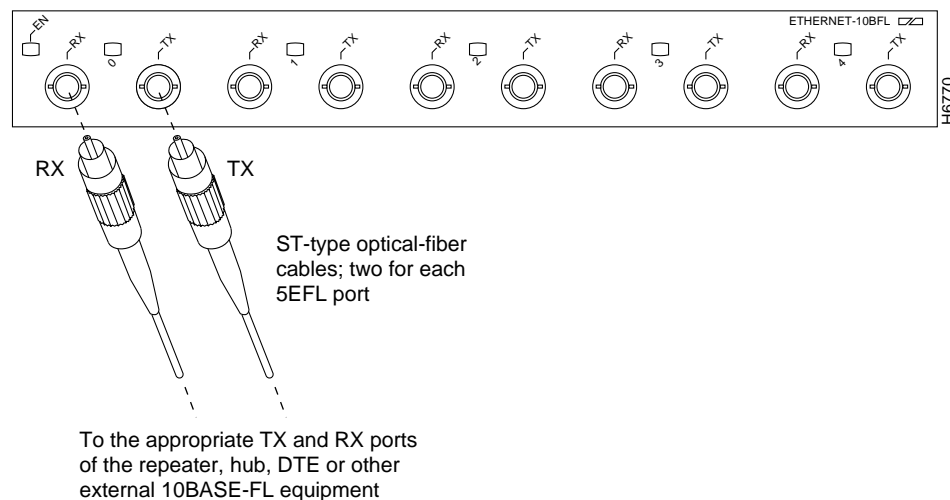

- Step 3** Connect a PA-5EFL port adapter RX port to the appropriate TX port of the repeater, hub, DTE, or other external 10Base-FL equipment.
- Step 4** Connect a PA-5EFL port adapter TX port to the appropriate RX port of the repeater, hub, DTE, or other external 10Base-FL equipment.
- Step 5** Repeat Steps 1 and 4 for each additional PA-5EFL interface connection you require.

This completes the procedure for attaching a multimode fiber-optic cable to the PA-5EFL port adapter. Proceed to [Chapter 4, “Configuring the PA-5EFL Port Adapter.”](#)



Configuring the PA-5EFL Port Adapter

To continue your Cisco PA-5EFL port adapter installation, you must configure the *Ethernet* interfaces. The instructions that follow apply to all supported platforms. Minor differences between the platforms—with Cisco IOS software commands—are noted.

This chapter contains the following sections:

- [Using the EXEC Command Interpreter, page 4-1](#)
- [Configuring the Interfaces, page 4-2](#)
- [Checking the Configuration, page 4-8](#)

Using the EXEC Command Interpreter

You modify the configuration of your router through the software command interpreter called the *EXEC* (also called enable mode). You must enter the privileged level of the EXEC command interpreter with the **enable** command before you can use the **configure** command to configure a new interface or change the existing configuration of an interface. The system prompts you for a password if one has been set.

The system prompt for the privileged level ends with a pound sign (#) instead of an angle bracket (>). At the console terminal, use the following procedure to enter the privileged level:

-
- Step 1** At the user-level EXEC prompt, enter the **enable** command. The EXEC prompts you for a privileged-level password as follows:

```
Router> enable
```

```
Password:
```

- Step 2** Enter the password (the password is case sensitive). For security purposes, the password is not displayed. When you enter the correct password, the system displays the privileged-level system prompt (#):

```
Router#
```

To configure the new interfaces, proceed to the [“Configuring the Interfaces” section on page 4-2](#).

Configuring the Interfaces

After you verify that the new PA-5EFL port adapter is installed correctly (the enabled LED goes on), use the privileged-level **configure** command to configure the new interfaces. Have the following information available:

- Protocols you plan to route on each new interface
- IP addresses, if you plan to configure the interfaces for IP routing
- Bridging protocols you plan to use

If you installed a new PA-5EFL port adapter or if you want to change the configuration of an existing interface, you must enter configuration mode to configure the new interfaces. If you replaced a PA-5EFL port adapter that was previously configured, the system recognizes the new interfaces and brings each of them up in their existing configuration.

For a summary of the configuration options available and instructions for configuring interfaces on a PA-5EFL port adapter, refer to the appropriate configuration publications listed in the [“Related Documentation”](#) section on page vi.

You execute configuration commands from the privileged level of the EXEC command interpreter, which usually requires password access. Contact your system administrator, if necessary, to obtain password access. (See the [“Using the EXEC Command Interpreter”](#) section on page 4-1 for an explanation of the privileged level of the EXEC.)

This section contains the following subsections:

- [Shutting Down an Interface, page 4-2](#)
- [Performing a Basic Configuration, page 4-6](#)

Shutting Down an Interface

Before you remove an interface that you will not replace, or replace port adapters, use the **shutdown** command to shut down (disable) the interfaces to prevent anomalies when you reinstall the new or reconfigured interface processor. When you shut down an interface, it is designated *administratively down* in the **show** command displays.

Follow these steps to shut down an interface:

-
- Step 1** Enter the privileged level of the EXEC command interpreter (also called enable mode). (See the [“Using the EXEC Command Interpreter”](#) section on page 4-1 for instructions.)
- Step 2** At the privileged-level prompt, enter configuration mode and specify that the console terminal is the source of the configuration subcommands, as follows:
- ```
Router# configure terminal
Enter configuration commands, one per line. End with CNTL/Z.
Router(config)#
```
- Step 3** Shut down interfaces by entering the **interface ethernet** subcommand (followed by the interface address of the interface) and then enter the **shutdown** command. [Table 4-1](#) shows the command syntax.
- When you have finished, press **Ctrl-Z**—hold down the **Control** key while you press **Z**—or enter **end** or **exit** to exit configuration mode and return to the EXEC command interpreter.

Table 4-1 Syntax of the shutdown Command

| Platform                  | Command                                                                                                                         | Example                                                                                                                                                                                                                                                                                                  |
|---------------------------|---------------------------------------------------------------------------------------------------------------------------------|----------------------------------------------------------------------------------------------------------------------------------------------------------------------------------------------------------------------------------------------------------------------------------------------------------|
| Cisco 7120 series routers | <b>interface</b> , followed by the <i>type (ethernet)</i> and <i>slot/port</i> (port-adapter-slot-number/interface-port-number) | The example is for interface 0 and interface 1 on a port adapter in port adapter slot 3.<br><br><pre>Router(config-if)# <b>interface ethernet 3/0</b> Router(config-if)# <b>shutdown</b> Router(config-if)# <b>interface ethernet 3/1</b> Router(config-if)# <b>shutdown</b> <b>Ctrl-Z</b> Router#</pre> |
| Cisco 7140 series routers | <b>interface</b> , followed by the <i>type (ethernet)</i> and <i>slot/port</i> (port-adapter-slot-number/interface-port-number) | The example is for interface 0 and interface 1 on a port adapter in port adapter slot 4.<br><br><pre>Router(config-if)# <b>interface ethernet 4/0</b> Router(config-if)# <b>shutdown</b> Router(config-if)# <b>interface ethernet 4/1</b> Router(config-if)# <b>shutdown</b> <b>Ctrl-Z</b> Router#</pre> |
| Cisco 7200 series routers | <b>interface</b> , followed by the <i>type (ethernet)</i> and <i>slot/port</i> (port-adapter-slot-number/interface-port-number) | The example is for interface 0 and interface 1 on a port adapter in port adapter slot 6.<br><br><pre>Router(config-if)# <b>interface ethernet 6/0</b> Router(config-if)# <b>shutdown</b> Router(config-if)# <b>interface ethernet 6/1</b> Router(config-if)# <b>shutdown</b> <b>Ctrl-Z</b> Router#</pre> |
| Cisco uBR7223 router      | <b>interface</b> , followed by the <i>type (ethernet)</i> and <i>slot/port</i> (port-adapter-slot-number/interface-port-number) | The example is for interface 0 and interface 1 on a port adapter in port adapter slot 1.<br><br><pre>Router(config-if)# <b>interface ethernet 1/0</b> Router(config-if)# <b>shutdown</b> Router(config-if)# <b>interface ethernet 1/1</b> Router(config-if)# <b>shutdown</b> <b>Ctrl-Z</b> Router#</pre> |
| Cisco uBR7246 router      | <b>interface</b> , followed by the <i>type (ethernet)</i> and <i>slot/port</i> (port-adapter-slot-number/interface-port-number) | The example is for interface 0 and interface 1 on a port adapter in port adapter slot 2.<br><br><pre>Router(config-if)# <b>interface ethernet 2/0</b> Router(config-if)# <b>shutdown</b> Router(config-if)# <b>interface ethernet 2/1</b> Router(config-if)# <b>shutdown</b> <b>Ctrl-Z</b> Router#</pre> |
| Cisco 7301 router         | <b>interface</b> , followed by the <i>type (ethernet)</i> and <i>slot/port</i> (port-adapter-slot-number/interface-port-number) | The example is for the 0 interface on a port adapter in slot 1.<br><br><pre>Router(config-if)# <b>interface ethernet 1/0</b> Router(config-if)# <b>shutdown</b> <b>Ctrl-Z</b> Router#</pre>                                                                                                              |

Table 4-1 Syntax of the shutdown Command (continued)

| Platform                                              | Command                                                                                                                                                                               | Example                                                                                                                                                                                                                                                                                                                                                           |
|-------------------------------------------------------|---------------------------------------------------------------------------------------------------------------------------------------------------------------------------------------|-------------------------------------------------------------------------------------------------------------------------------------------------------------------------------------------------------------------------------------------------------------------------------------------------------------------------------------------------------------------|
| VIP in Cisco 7000 series or Cisco 7500 series routers | <b>interface</b> , followed by the <i>type</i> ( <b>ethernet</b> ) and <i>slot/port adapter/port</i> (interface-processor-slot-number/port-adapter-slot-number/interface-port-number) | The example is for interface 0 and interface 1 on a port adapter in port adapter slot 1 of a VIP installed in interface processor slot 1.<br><br>Router(config-if)# <b>interface ethernet 1/1/0</b><br>Router(config-if)# <b>shutdown</b><br>Router(config-if)# <b>interface ethernet 1/1/0</b><br>Router(config-if)# <b>shutdown</b><br><b>Ctrl-Z</b><br>Router# |



**Note** If you need to shut down additional interfaces, enter the **interface ethernet** command (followed by the interface address of the interface) for each of the interfaces on your port adapter. Use the **no shutdown** command to enable the interface.

**Step 4** Write the new configuration to NVRAM as follows:

```
Router# copy running-config startup-config
[OK]
Router#
```

The system displays an OK message when the configuration has been stored in NVRAM.

**Step 5** Verify that new interfaces are now in the correct state (shut down) using the **show interfaces ethernet** command (followed by the interface address of the interface) to display the specific interface. Table 4-2 provides examples.

Table 4-2 Examples of show interfaces Command

| Platform                  | Command                                                                                                         | Example                                                                                                                                                                                                                                                        |
|---------------------------|-----------------------------------------------------------------------------------------------------------------|----------------------------------------------------------------------------------------------------------------------------------------------------------------------------------------------------------------------------------------------------------------|
| Cisco 7120 series routers | <b>show interfaces ethernet</b> , followed by <i>slot/port</i> (port-adapter-slot-number/interface-port-number) | The example is for interface 0 on a port adapter in port adapter slot 1.<br><br>Router# <b>show interfaces ethernet 1/0</b><br><br>Serial 1/0 is administratively down,<br>line protocol is down<br><br>[Additional display text omitted from<br>this example] |
| Cisco 7140                | <b>show interfaces ethernet</b> , followed by <i>slot/port</i> (port-adapter-slot-number/interface-port-number) | The example is for interface 0 on a port adapter in port adapter slot 1.<br><br>Router# <b>show interfaces ethernet 1/0</b><br><br>Serial 1/0 is administratively down,<br>line protocol is down<br><br>[Additional display text omitted from<br>this example] |

Table 4-2 Examples of show interfaces Command (continued)

| Platform                                               | Command                                                                                                                                                      | Example                                                                                                                                                                                                                                                                                                      |
|--------------------------------------------------------|--------------------------------------------------------------------------------------------------------------------------------------------------------------|--------------------------------------------------------------------------------------------------------------------------------------------------------------------------------------------------------------------------------------------------------------------------------------------------------------|
| Cisco 7200 series                                      | <b>show interfaces ethernet</b> , followed by <i>slot/port</i> (port-adapter-slot-number/interface-port-number)                                              | The example is for interface 0 on a port adapter in port adapter slot 6.<br><br>Router# <b>show interfaces ethernet 6/0</b><br><br>Serial 6/0 is administratively down,<br>line protocol is down<br><br>[Additional display text omitted from<br>this example]                                               |
| Cisco uBB7223 router                                   | <b>show interfaces ethernet</b> , followed by <i>slot/port</i> (port-adapter-slot-number/interface-port-number)                                              | The example is for interface 0 on a port adapter in port adapter slot 1.<br><br>Router# <b>show interfaces ethernet 1/0</b><br><br>Serial 1/0 is administratively down,<br>line protocol is down<br><br>[Additional display text omitted from<br>this example]                                               |
| Cisco uBR7246 router                                   | <b>show interfaces ethernet</b> , followed by <i>slot/port</i> (port-adapter-slot-number/interface-port-number)                                              | The example is for interface 0 on a port adapter in port adapter slot 2.<br><br>Router# <b>show interfaces ethernet 2/0</b><br><br>Serial 2/0 is administratively down,<br>line protocol is down<br><br>[Additional display text omitted from<br>this example]                                               |
| Cisco 7301 router                                      | <b>show interfaces ethernet</b> , followed by <i>slot/port</i> (port-adapter-slot-number/interface-port-number)                                              | The example is for interface 0 on a port adapter in port adapter slot 1.<br><br>Router# <b>show interfaces ethernet 1/0</b><br><br>Serial 1/0 is administratively down,<br>line protocol is down<br><br>[Additional display text omitted from<br>this example]                                               |
| VIP2 in Cisco 7000 series or Cisco 7500 series routers | <b>show interfaces ethernet</b> , followed by <i>slot/port adapter/port</i> (interface-processor-slot-number/port-adapter-slot-number/interface-port-number) | The example is for interface 0 on a port adapter in port adapter slot 1 of a VIP2 in interface processor slot 1.<br><br>Router# <b>show interfaces ethernet 1/1/0</b><br><br>Ethernet 1/1/0 is administratively<br>down, line protocol is down<br><br>[Additional display text omitted from<br>this example] |

- Step 6** Reenable interfaces by doing the following:
- Repeat Step 3 to reenable an interface. Substitute the **no shutdown** command for the **shutdown** command.
  - Repeat Step 4 to write the new configuration to memory. Use the **copy running-config startup-config** command.
  - Repeat Step 5 to verify that the interfaces are in the correct state. Use the **show interfaces ethernet** command followed by the interface address of the interface.

For complete descriptions of software configuration commands, refer to the publications listed in the “[Related Documentation](#)” section on page vi.

## Performing a Basic Configuration

Following are instructions for a basic configuration: enabling an interface and specifying IP routing. You might also need to enter other configuration subcommands, depending on the requirements for your system configuration and the protocols you plan to route on the interface. For complete descriptions of configuration subcommands and the configuration options available for ethernet interfaces, refer to the appropriate software documentation.

In the following procedure, press the **Return** key after each step unless otherwise noted. At any time you can exit the privileged level and return to the user level by entering **disable** at the prompt as follows:

```
Router# disable
```

```
Router>
```

- Step 1** Enter configuration mode and specify that the console terminal is the source of the configuration subcommands, as follows:

```
Router# configure terminal
Enter configuration commands, one per line. End with CNTL/Z.
Router(config)#
```

- Step 2** Specify the first interface to configure by entering the **interface ethernet** subcommand, followed by the interface address of the interface you plan to configure. [Table 4-3](#) gives examples.

**Table 4-3** Examples of interface ethernet Subcommand

| Platform                  | Command                                                                                                          | Example                                                                                                                                                 |
|---------------------------|------------------------------------------------------------------------------------------------------------------|---------------------------------------------------------------------------------------------------------------------------------------------------------|
| Cisco 7120 series routers | <b>interface ethernet</b> , followed by <i>slot/port</i><br>(port-adapter-slot-number/<br>interface-port-number) | The example is for the first interface of a port adapter in port adapter slot 3.<br>Router(config)# <b>interface ethernet 3/0</b><br>Router(config-if)# |
| Cisco 7140 series routers | <b>interface ethernet</b> , followed by <i>slot/port</i><br>(port-adapter-slot-number/<br>interface-port-number) | The example is for the first interface of a port adapter in port adapter slot 4.<br>Router(config)# <b>interface ethernet 4/0</b><br>Router(config-if)# |

Table 4-3 Examples of interface ethernet Subcommand (continued)

| Platform                                               | Command                                                                                                                                                           | Example                                                                                                                                                                                               |
|--------------------------------------------------------|-------------------------------------------------------------------------------------------------------------------------------------------------------------------|-------------------------------------------------------------------------------------------------------------------------------------------------------------------------------------------------------|
| Cisco 7200 series routers                              | <b>interface ethernet</b> , followed by <i>slot/port</i><br>(port-adapter-slot-number/<br>interface-port-number)                                                  | The example is for the first interface of a port adapter in port adapter slot 1.<br><br>Router(config)# <b>interface ethernet 1/0</b><br>Router(config-if)#                                           |
| Cisco uBR7223 router                                   | <b>interface ethernet</b> , followed by <i>slot/port</i><br>(port-adapter-slot-number/<br>interface-port-number)                                                  | The example is for the first interface of a port adapter in port adapter slot 1.<br><br>Router(config)# <b>interface ethernet 1/0</b><br>Router(config-if)#                                           |
| Cisco uBR7246 router                                   | <b>interface ethernet</b> , followed by <i>slot/port</i><br>(port-adapter-slot-number/<br>interface-port-number)                                                  | The example is for the first interface of a port adapter in port adapter slot 2.<br><br>Router(config)# <b>interface ethernet 2/0</b><br>Router(config-if)#                                           |
| Cisco 7301 router                                      | <b>interface ethernet</b> , followed by <i>slot/port</i><br>(port-adapter-slot-number/<br>interface-port-number)                                                  | The example is for the first interface of a port adapter in port adapter slot 1.<br><br>Router(config)# <b>interface ethernet 1/0</b><br>Router(config-if)#                                           |
| VIP2 in Cisco 7000 series or Cisco 7500 series routers | <b>interface ethernet</b> , followed by <i>slot/port adapter/port</i><br>(interface-processor-slot-number/<br>port-adapter-slot-number/<br>interface-port-number) | The example is for the first interface of a port adapter in port adapter slot 1 of a VIP2 in interface processor slot 1.<br><br>Router(config)# <b>interface ethernet 1/1/0</b><br>Router(config-if)# |

- Step 3** Assign an IP address and subnet mask to the interface (if IP routing is enabled on the system) by using the **ip address** subcommand, as in the following example:

```
Router(config-if)# ip address 10.0.0.0 10.255.255.255
```

- Step 4** Add any additional configuration subcommands required to enable routing protocols and set the interface characteristics.
- Step 5** Reenable the interfaces using the **no shutdown** command. (See the “[Shutting Down an Interface](#)” section on page 4-2.)
- Step 6** Configure all additional port adapter interfaces as required.
- Step 7** After including all of the configuration subcommands to complete your configuration, press **Ctrl-Z**—hold down the **Control** key while you press **Z**—or enter **end** or **exit** to exit configuration mode and return to the EXEC command interpreter prompt.
- Step 8** Write the new configuration to NVRAM as follows:

```
Router# copy running-config startup-config
[OK]
Router#
```

This completes the procedure for creating a basic configuration.

# Checking the Configuration

After configuring the new interface, use the **show** commands to display the status of the new interface or all interfaces, and use the **ping** and **loopback** commands to check connectivity. This section includes the following subsections:

- [Using show Commands to Verify the New Interface Status, page 4-8](#)
- [Using the ping Command to Verify Network Connectivity, page 4-19](#)
- [Using loopback Commands, page 4-19](#)

## Using show Commands to Verify the New Interface Status

Table 4-4 demonstrates how you can use the **show** commands to verify that new interfaces are configured and operating correctly and that the *PA-5EFL* appears in them correctly. Sample displays of the output of selected **show** commands appear in the sections that follow. For complete command descriptions and examples, refer to the publications listed in the “[Related Documentation](#)” section on page vi.



### Note

The outputs that appear in this document may not match the output you receive when running these commands. The outputs in this document are examples only.

**Table 4-4** Using show Commands

| Command                                                                                         | Function                                                                                                                                                                   | Example                                     |
|-------------------------------------------------------------------------------------------------|----------------------------------------------------------------------------------------------------------------------------------------------------------------------------|---------------------------------------------|
| <b>show version</b> or<br><b>show hardware</b>                                                  | Displays system hardware configuration, the number of each interface type installed, Cisco IOS software version, names and sources of configuration files, and boot images | Router# <b>show version</b>                 |
| <b>show controllers</b>                                                                         | Displays all the current interface processors and their interfaces                                                                                                         | Router# <b>show controllers</b>             |
| <b>show diag slot</b>                                                                           | Displays types of port adapters installed in your system and information about a specific port adapter slot, interface processor slot, or chassis slot                     | Router# <b>show diag 2</b>                  |
| <b>show interfaces type 1/</b><br><i>interface-port-number</i>                                  | Displays status information about a specific type of interface (for example, ethernet) in a Cisco 7120 series router                                                       | Router# <b>show interfaces ethernet 1/1</b> |
| <b>show interfaces type 4/</b><br><i>interface-port-number</i>                                  | Displays status information about a specific type of interface (for example, ethernet) in a Cisco 7140 series router                                                       | Router# <b>show interfaces ethernet 4/1</b> |
| <b>show interfaces type</b><br><i>port-adapter-slot-number/</i><br><i>interface-port-number</i> | Displays status information about a specific type of interface (for example, ethernet) in a Cisco 7200 series router                                                       | Router# <b>show interfaces ethernet 1/0</b> |

Table 4-4 Using show Commands (continued)

| Command                                                                                                                                           | Function                                                                                                                                            | Example                                       |
|---------------------------------------------------------------------------------------------------------------------------------------------------|-----------------------------------------------------------------------------------------------------------------------------------------------------|-----------------------------------------------|
| <b>show interfaces</b> <i>type 1/</i><br><i>interface-port-number</i>                                                                             | Displays status information about a specific type of interface (for example, ethernet) in a Cisco uBR7223 router                                    | Router# <b>show interfaces ethernet 1/1</b>   |
| <b>show interfaces</b> <i>type 1 or 2/</i><br><i>interface-port-number</i>                                                                        | Displays status information about a specific type of interface (for example, ethernet) in a Cisco uBR7246 router                                    | Router# <b>show interfaces ethernet 2/0</b>   |
| <b>show interfaces</b> <i>type 1/</i><br><i>interface-port-number</i>                                                                             | Displays status information about a specific type of interface (for example, ethernet) in a Cisco 7301 router                                       | Router# <b>show interfaces ethernet 1/0</b>   |
| <b>show interfaces</b> <i>type</i><br><i>interface-processor-slot-number/</i><br><i>port-adapter-slot-number/</i><br><i>interface-port-number</i> | Displays status information about a specific type of interface (for example, ethernet) on a VIP2 in a Cisco 7000 series or Cisco 7500 series router | Router# <b>show interfaces ethernet 3/1/0</b> |
| <b>show protocols</b>                                                                                                                             | Displays protocols configured for the entire system and for specific interfaces                                                                     | Router# <b>show protocols</b>                 |
| <b>show running-config</b>                                                                                                                        | Displays the running configuration file                                                                                                             | Router# <b>show running-config</b>            |
| <b>show startup-config</b>                                                                                                                        | Displays the configuration stored in NVRAM                                                                                                          | Router# <b>show startup-config</b>            |

If an interface is shut down and you configured it as up, or if the displays indicate that the hardware is not functioning properly, ensure that the interface is properly connected and terminated. If you still have problems bringing up the interface, contact a service representative for assistance. This section includes the following subsections:

- [Using the show version or show hardware Commands, page 4-9](#)
- [Using the show diag Command, page 4-12](#)
- [Using the show interfaces Command, page 4-14](#)

Choose the subsection appropriate for your system. Proceed to the [“Using the ping Command to Verify Network Connectivity”](#) section on [page 4-19](#) when you have finished using the **show** commands.

## Using the show version or show hardware Commands

Display the configuration of the system hardware, the number of each interface type installed, the Cisco IOS software version, the names and sources of configuration files, and the boot images, using the **show version** (or **show hardware**) command. The following sections offer some platform-specific output examples using the show version command.



### Note

The outputs that appear in this document may not match the output you receive when running these commands. The outputs in this document are examples only.

## Cisco 7100 Series Routers

Following is an example of the **show version** command from a Cisco 7120 series router.

```
Router# show version
Cisco Internetwork Operating System Software
IOS (tm) EGR Software (c7100-IS-M), Version 12.0(4)XE, EARLY DEPLOYMENT
RELEASE)
TAC:Home:SW:IOS:Specials for info
Copyright (c) 1986-1999 by cisco Systems, Inc.
Compiled Thu 10-Jun-99 15:32 by linda
Image text-base:0x60008900, data-base:0x60D8E000

ROM:System Bootstrap, Version 12.0(19990720:023243)
[gautham-conn_4xe-PRE_ALPHE
BOOTFLASH:EGR Software (c7100-IS-M), Version 12.0(4)XE, EARLY DEPLOYMENT
RELEA)

Router uptime is 24 minutes
System restarted by power-on
System image file is "disk0:c7100-is-mz.120-4.XE"

cisco 7120-bad (EGR) processor with 61440K/69632K bytes of memory.
R527x CPU at 225Mhz, Implementation 40, Rev 10.0, 2048KB L2 Cache
Last reset from power-on
Bridging software.
X.25 software, Version 3.0.0.
4 Ethernet/IEEE 802.3 interfaces.
125K bytes of non-volatile configuration memory.

40960K bytes of ATA PCMCIA card at slot 0 (Sector size 512 bytes).
8192K bytes of Flash internal SIMM (Sector size 256K).
Configuration register is 0x2000
```

## Cisco 7200 Series and Cisco uBR7200 Series Routers

Following is an example of the **show version** command from a Cisco 7200 series router.

```
Router# show version

Cisco Internetwork Operating System Software
IOS (tm) 7200 Software (C7200-J-M), Version 11.1(7)CA [biff 105]
Copyright (c) 1986-1996 by cisco Systems, Inc.
Compiled Sun 04-Aug-96 06:00 by biff
Image text-base: 0x600088A0, data-base: 0x605A4000

ROM: System Bootstrap, Version 11.1(7)CA RELEASED SOFTWARE

Router uptime is 4 hours, 22 minutes
System restarted by reload
System image file is "c7200-j-mz", booted via slot0

cisco 7206 (NPE150) processor with 12288K/4096K bytes of memory.
R4700 processor, Implementation 33, Revision 1.0 (Level 2 Cache)
Last reset from power-on
Bridging software.
SuperLAT software (copyright 1990 by Meridian Technology Corp).
X.25 software, Version 2.0, NET2, BFE and GOSIP compliant.
TN3270 Emulation software (copyright 1994 by TGV INC).
Chassis Interface.
4 Ethernet/IEEE 802.3 interfaces.
2 FastEthernet/IEEE 802.3 interfaces.
4 Token Ring /IEEE802.5 interfaces.
```

```

12 Serial network interfaces.
1 Compression port adapter.
125K bytes of non-volatile configuration memory.
1024K bytes of packet SRAM memory.

20480K bytes of Flash PCMCIA card at slot 0 (Sector size 128K).
8192K bytes of Flash internal SIMM (Sector size 256K).
Configuration register is 0x2

```

## Cisco 7301 Routers

```

Router# show version
Cisco Internetwork Operating System Software
IOS (tm) 7301 Software (C7300-JS-M), Experimental Version 12.2(20020904:004736) [biff 107]
Copyright (c) 1986-2002 by cisco Systems, Inc.
Compiled Mon 09-Sep-02 18:02 by biff
Image text-base:0x600088F8, data-base:0x61A94000

ROM: System Bootstrap, Version 12.2(20020730:200705) [biff-TAZ2_QA_RELEASE_16B 101],
DEVELOPMENT SOFTWARE
BOOTLDR:7301 Software (C7301-BOOT-M), Experimental Version 12.2(20020813:014224)
[biff-TAZ2_QA_RELEASE_17B 101]

7301p2b uptime is 0 minutes
System returned to ROM by reload at 00:01:51 UTC Sat Jan 1 2000
System image file is "tftp://10.1.8.11/tazii/images/c7301-js-mz"

cisco 7301 (NPE-G1) processor (revision A) with 491520K/32768K bytes of memory.
Processor board ID 0
BCM1250 CPU at 700Mhz, Implementation 1, Rev 0.2, 512KB L2 Cache
1 slot midplane, Version 2.0

Last reset from power-on
Bridging software.
X.25 software, Version 3.0.0.
SuperLAT software (copyright 1990 by Meridian Technology Corp).
TN3270 Emulation software.
3 Gigabit Ethernet/IEEE 802.3 interface(s)
509K bytes of non-volatile configuration memory.

62976K bytes of ATA PCMCIA card at slot 0 (Sector size 512 bytes).
32768K bytes of Flash internal SIMM (Sector size 256K).
Configuration register is 0x102

```

## VIP2 in Cisco 7000 Series and Cisco 7500 Series Routers

Following is an example of the **show version** command from a Cisco 7500 series router.

```

Router# show version

Cisco Internetwork Operating System Software
IOS (tm) GS Software (RSP-A), Version 11.1(7)CA [biff 125]
Copyright (c) 1986-1996 by cisco Systems, Inc.
Compiled Sat 10-Aug-96 17:56 by biff
Image text-base: 0x600108A0, data-base: 0x60952000

ROM: System Bootstrap, Version 5.3(16645) [biff 571], RELEASE SOFTWARE
ROM: GS Software (RSP-BOOT-M), Version 11.1(7)CA, RELEASE SOFTWARE (fc1)

Router uptime is 5 days, 4 minutes
System restarted by reload

```

```

System image file is "rsp-jv-mz", booted via slot0

cisco RSP2 (R4600) processor with 16384K bytes of memory.
R4600 processor, Implementation 32, Revision 2.0
Last reset from power-on
G.703/E1 software, Version 1.0.
SuperLAT software (copyright 1990 by Meridian Technology Corp).
Bridging software.
X.25 software, Version 2.0, NET2, BFE and GOSIP compliant.
TN3270 Emulation software (copyright 1994 by TGV Inc).
Chassis Interface.
1 EIP controller (6 Ethernet).
1 VIP2 controller (8 Ethernet)(1 HSSI).
14 Ethernet/IEEE 802.3 interfaces.
1 HSSI network interface.
125K bytes of non-volatile configuration memory.

8192K bytes of Flash PCMCIA card at slot 0 (Sector size 128K).
8192K bytes of Flash internal SIMM (Sector size 256K).
Configuration register is 0x0

```

## Using the show diag Command

Display the types of port adapters installed in your system (and specific information about each) using the `show diag slot` command, where *slot* is the *port adapter slot* in a Cisco 7200 series routers, Cisco uBR7200 series router, and the Cisco 7301 router, and the *interface processor slot* in a Cisco 7000 series or Cisco 7500 series router with a VIP2.

The following sections offer some platform-specific output examples using the show version command.



### Note

---

The outputs that appear in this document may not match the output you receive when running these commands. The outputs in this document are examples only.

---

## Cisco 7100 Series Routers

Following is an example of the `show diag slot` command that shows a PA-5EFL port adapter in port-adapter slot 3 of a Cisco 7120 series router.

```

Router# show diag 3
Slot 3:
 Ethernet port adapter, 5 ports
 Integrated port adapter is analyzed
 EEPROM contents at hardware discovery:
 Hardware revision 255.255 Board revision UNKNOWN
 EEPROM format version 1
 EEPROM contents (hex):
 0x20:01 D3 FF FF FF FF FF FF FF FF FF FF FF FF FF FF
 0x30:FF FF FF FF FF FF FF FF FF FF FF FF FF FF FF

```



### Note

---

To use the `show diag` command with the Cisco 7140 series router, replace the slot argument **3** with **4**.

---

## Cisco 7200 Series and Cisco uBR7200 Series Routers

Following is an example of the `show diag slot` command that shows a PA-5EFL port adapter in port adapter slot 2 of a Cisco 7200 series router.

```
Router# show diag 2
Slot 2:
Ethernet port adapter, 5 ports
Port adapter is analyzed
Port adapter insertion time 2d09h ago
Hardware revision 255.255 Board revision UNKNOWN
Serial number 4294967295 Part number 255-65535-255
Test history 0xFF RMA number 255-255-255
EEPROM format version 1
EEPROM contents (hex):
0x20: 01 0D FF FF FF FF FF FF FF FF FF FF FF FF FF
0x30: FF FF FF FF FF FF FF FF FF FF FF FF FF FF FF
```



### Note

Port adapters used with the Cisco 7200 VXR routers require the correct base hardware revision in order to function. The following error message occurs on bootup if the incorrect hardware revision is used:

```
> PA-3-REVNOTSUPPORTED:PA in slot 1 (Ethernet) requires base h/w revision of (1.5) for this chassis
```

Use the `show diag` command to display the hardware revision.

## Cisco 7301 Routers



### Note

Input/output data for the console port, auxiliary port, Gigabit Ethernet ports, and CompactFlash Disk are listed in the output of the `show c7300` command, rather than in the output of the `show diag` command. Use the `show diag` command for port adapter information.

```
Router# sh diag

Slot 1:
 POS Single Width, Multi Mode Port adapter, 1 port
 Port adapter is analyzed
 Port adapter insertion time 01:38:29 ago
 EEPROM contents at hardware discovery:
 Hardware revision 2.2 Board revision A0
 Serial number 28672741 Part number 73-3192-06
 FRU Part Number:PA-POS-OC3MM=

 Test history 0x0 RMA number 00-00-00
 EEPROM format version 1
 EEPROM contents (hex):
 0x20:01 96 02 02 01 B5 82 E5 49 0C 78 06 00 00 00 00
 0x30:50 00 00 00 02 08 19 00 00 00 FF FF FF FF FF FF
```

## VIP2 in Cisco 7000 Series and Cisco 7500 Series Routers

Following is an example of the `show diag slot` command that shows a PA-5EFL in port adapter slot 0 on a VIP2 in interface processor slot 1.

```
Router# show diag 1
Slot 1:
 Physical slot 1, ~physical slot 0xE, logical slot 1, CBus 0
 Microcode Status 0xC
 Master Enable, LED, WCS Loaded
 Board is analyzed
 Pending I/O Status: Console I/O
 EEPROM format version 1
 VIP2 controller, HW rev 2.2, board revision UNKNOWN
 Serial number: 03508056 Part number: 73-1554-02
 Test history: 0x00 RMA number: 43-27-00
 Flags: cisco 7000 board; 7500 compatible

 EEPROM contents (hex):
 0x20: 01 15 02 02 00 35 87 58 49 06 12 02 00 2B 1B 00
 0x30: 12 2B 00 2A 1A 00 00 00 00 00 00 00 00 00 00 00

 Slot database information:
 Flags: 0x4 Insertion time: 0x10DC (00:01:17 ago)

 Controller Memory Size: 8 MBytes
 PA Bay 1 Information:
 Ethernet PA, 5 ports
 EEPROM format version 1
 HW rev 1.0, Board revision 6
 Serial number: 03522225 Part number: 73-1679-01
```

## Using the show interfaces Command

The `show interfaces` command displays status information (including the physical slot and interface address) for the interfaces you specify. All of the examples that follow specify ethernet interface.

For complete descriptions of interface subcommands and the configuration options available for Cisco 7100, Cisco 7200, Cisco uBR7200, Cisco 7301, and VIP2 interfaces, refer to the publications listed in the [“Related Documentation” section on page vi](#). The following sections offer some platform-specific output examples using the `show interfaces` command.



### Note

The outputs that appear in this document may not match the output you receive when running these commands. The outputs in this document are examples only.

## Cisco 7100 Series

Following is an example of the `show interfaces` command used with a Cisco 7120 series router and a Cisco 7140 series router.

In this example, the five ethernet interfaces (0 to 4) are on a port adapter in port adapter slot 3 of a Cisco 7120 series router; also, most of the status information for each interface is omitted. (Interfaces are administratively shut down until you enable them.)

```
Router# show interfaces ethernet 3/0
Ethernet3/0 is up, line protocol is up
 Hardware is AmdP2 Ethernet
 Internet address is 10.0.0.0
 MTU 1500 bytes, BW 1544 Kbit, DLY 20000 usec, rely 255/255, load 1/255
```

```
Encapsulation HDLC, loopback not set, keepalive set (10 sec)
[Additional display text omitted from this example]
```

```
Router# show interfaces ethernet 3/1
Ethernet3/1 is up, line protocol is up
 Hardware is AmdP2 Ethernet
 Internet address is 10.0.0.1
 MTU 1500 bytes, BW 1544 Kbit, DLY 20000 usec, rely 255/255, load 1/255
 Encapsulation HDLC, loopback not set, keepalive set (10 sec)
[Additional display text omitted from this example]
```

```
Router# show interfaces ethernet 3/2
Ethernet3/2 is up, line protocol is up
 Hardware is AmdP2 Ethernet
 Internet address is 10.0.0.2
 MTU 1500 bytes, BW 1544 Kbit, DLY 20000 usec, rely 255/255, load 1/255
 Encapsulation HDLC, loopback not set, keepalive set (10 sec)
[Additional display text for remaining interfaces omitted]
```

```
Router# show interfaces ethernet 3/3
Ethernet3/3 is up, line protocol is up
 Hardware is AmdP2 Ethernet
 Internet address is 10.0.0.3
 MTU 1500 bytes, BW 1544 Kbit, DLY 20000 usec, rely 255/255, load 1/255
 Encapsulation HDLC, loopback not set, keepalive set (10 sec)
[Additional display text for remaining interfaces omitted]
```

```
Router# show interfaces ethernet 3/4
Ethernet3/4 is up, line protocol is up
 Hardware is AmdP2 Ethernet
 Internet address is 10.0.0.4
 MTU 1500 bytes, BW 1544 Kbit, DLY 20000 usec, rely 255/255, load 1/255
 Encapsulation HDLC, loopback not set, keepalive set (10 sec)
[Additional display text for remaining interfaces omitted]
```

**Note**

To use the **show interfaces ethernet** command with the Cisco 7140 series router, replace the interface address arguments **3/0**, **3/1**, **3/2**, **3/3**, and **3/4** with **4/0**, **4/1**, **4/2**, **4/3**, and **4/4**, respectively.

**Cisco 7120 Router**

Following is an example of the **show interfaces ethernet** command, which shows all of the information specific to interface 0 on a PA-5EFL port adapter installed in port adapter slot 3 of a Cisco 7120 router.

```
Router# show interfaces ethernet 3/0
Ethernet3/0 is up, line protocol is up
Hardware is AmdP2 Ethernet
 MTU 1500 bytes, BW 1544 Kbit, DLY 20000 usec, rely 255/255, load 1/255
 Encapsulation HDLC, loopback not set, keepalive set (10 sec)
 Last input never, output 1d17h, output hang never
 Last clearing of "show interface" counters never
 Output queue 0/40, 0 drops; input queue 0/75, 0 drops
 5 minute input rate 0 bits/sec, 0 packets/sec
 5 minute output rate 0 bits/sec, 0 packets/sec
 0 packets input, 0 bytes, 0 no buffer
 Received 0 broadcasts, 0 runts, 0 giants
 0 input errors, 0 CRC, 0 frame, 0 overrun, 0 ignored, 0 abort
 24 packets output, 5137 bytes, 0 underruns
 0 output errors, 0 collisions, 0 interface resets
 0 output buffer failures, 0 output buffers swapped out
 0 carrier transitions DCD=down DSR=down DTR=down RTS=down CTS=down
```

**Note**

To use the **show interfaces ethernet** command with the Cisco 7140 router, replace the interface address argument **3/0** with **4/0**.

**Cisco 7200 Series and Cisco uBR7200 Series Routers**

Following is an example of the **show interfaces** command for Cisco 7200 series and Cisco uBR7200 series routers. In the example, the five ethernet interfaces (0 to 4) are on a port adapter in port adapter slot 2; also, most of the status information for each interface is omitted. (Interfaces are administratively shut down until you enable them.)

```
Router# show interfaces ethernet 2/0
Ethernet2/0 is administratively down, line protocol is down
 Hardware is AmdP2 Ethernet, address is 10.0.0.0 (bia 0000.0ca5.2389)
 MTU 1500 bytes, BW 10000 Kbit, DLY 1000 usec, rely 255/255, load 1/255
 Encapsulation ARPA, loopback not set, keepalive set (10 sec)
[Additional display text omitted from this example]
```

```
Router# show interfaces ethernet 2/1
Ethernet2/1 is administratively down, line protocol is down
 Hardware is AmdP2 Ethernet, address is 10.0.0.1 (bia 0000.0ca5.238a)
 MTU 1500 bytes, BW 10000 Kbit, DLY 1000 usec, rely 255/255, load 1/255
 Encapsulation ARPA, loopback not set, keepalive set (10 sec)
[Additional display text omitted from this example]
```

```
Router# show interfaces ethernet 2/2
Ethernet2/2 is administratively down, line protocol is down
 Hardware is AmdP2 Ethernet, address is 10.0.0.2 (bia 0000.0ca5.238b)
 MTU 1500 bytes, BW 10000 Kbit, DLY 1000 usec, rely 255/255, load 1/255
 Encapsulation ARPA, loopback not set, keepalive set (10 sec)
[Additional display text omitted from this example]
```

```
Router# show interfaces ethernet 2/3
Ethernet2/3 is administratively down, line protocol is down
 Hardware is AmdP2 Ethernet, address is 10.0.0.3 (bia 0000.0ca5.238c)
 MTU 1500 bytes, BW 10000 Kbit, DLY 1000 usec, rely 255/255, load 1/255
 Encapsulation ARPA, loopback not set, keepalive set (10 sec)
[Additional display text omitted from this example]
```

```
Router# show interfaces ethernet 2/4
Ethernet2/4 is administratively down, line protocol is down
 Hardware is AmdP2 Ethernet, address is 10.0.0.4 (bia 0000.0ca5.238d)
 MTU 1500 bytes, BW 10000 Kbit, DLY 1000 usec, rely 255/255, load 1/255
 Encapsulation ARPA, loopback not set, keepalive set (10 sec)
[Additional display text omitted from this example]
```

Following is an example of the **show interfaces ethernet** command, which shows all of the information specific to interface port 0 on a PA-5EFL installed in port adapter slot 2.

```
Router# show interfaces ethernet 2/0
Ethernet2/0 is administratively down, line protocol is down
 Hardware is AmdP2 Ethernet, address is 10.0.0.0 (bia 0000.0ca5.238e)
 MTU 1500 bytes, BW 10000 Kbit, DLY 1000 usec, rely 255/255, load 1/255
 Encapsulation ARPA, loopback not set, keepalive set (10 sec)
 ARP type: ARPA, ARP Timeout 4:00:00
 Last input never, output never, output hang never
 Last clearing of "show interface" counters 2:56:26
 Output queue 0/40, 0 drops; input queue 0/75, 0 drops
 5 minute input rate 0 bits/sec, 0 packets/sec
 5 minute output rate 0 bits/sec, 0 packets/sec
```

```

0 packets input, 0 bytes, 0 no buffer
Received 0 broadcasts, 0 runts, 0 giants
0 input errors, 0 CRC, 0 frame, 0 overrun, 0 ignored, 0 abort
0 input packets with dribble condition detected
0 packets output, 0 bytes, 0 underruns
0 output errors, 0 collisions, 0 interface resets, 0 restarts
0 output buffer failures, 0 output buffers swapped out

```

## Cisco 7301 Router

Following is an example of the **show interfaces** command for Cisco 7301 routers. Most of the status information for each interface is omitted. (Interfaces are administratively shut down until you enable them.)

```

outer# show interfaces
GigabitEthernet0/0 is up, line protocol is up
 Hardware is BCM1250 Internal MAC, address is 0005.dd2c.7c1b (bia 0005.dd2c.7c1b)
 Internet address is 10.1.3.153/16
 MTU 1500 bytes, BW 100000 Kbit, DLY 100 usec,
 reliability 255/255, txload 1/255, rxload 1/255
 Encapsulation ARPA, loopback not set
 Keepalive set (10 sec)
 Half-duplex, 100Mb/s, media type is RJ45
 output flow-control is off, input flow-control is off
 ARP type:ARPA, ARP Timeout 04:00:00
 Last input 00:00:01, output 00:00:07, output hang never
 Last clearing of "show interface" counters 19:00:50
 Input queue:0/75/63658/0 (size/max/drops/flushes); Total output drops:0

```

(display text omitted)

```

GigabitEthernet0/1 is up, line protocol is up
 Hardware is BCM1250 Internal MAC, address is 0005.dd2c.7c1a (bia 0005.dd2c.7c1a)
 Internet address is 192.18.1.1/24
 MTU 1500 bytes, BW 1000000 Kbit, DLY 10 usec,
 reliability 255/255, txload 5/255, rxload 6/255
 Encapsulation ARPA, loopback not set
 Keepalive set (10 sec)
 Full-duplex, 1000Mb/s, link type is autonegotiation, media type is SX
 output flow-control is off, input flow-control is off
 ARP type:ARPA, ARP Timeout 04:00:00
 Last input 18:56:46, output 00:00:09, output hang never
 Last clearing of "show interface" counters 19:00:52
 Input queue:0/75/16176489/0 (size/max/drops/flushes); Total output drops:0

```

(display text omitted)

```

GigabitEthernet0/2 is up, line protocol is up
 Hardware is BCM1250 Internal MAC, address is 0005.dd2c.7c19 (bia 0005.dd2c.7c19)
 Internet address is 1.1.1.1/24
 MTU 1500 bytes, BW 1000000 Kbit, DLY 10 usec,
 reliability 255/255, txload 1/255, rxload 5/255
 Encapsulation ARPA, loopback not set
 Keepalive set (10 sec)
 Full-duplex, 1000Mb/s, link type is autonegotiation, media type is SX
 output flow-control is off, input flow-control is off
 ARP type:ARPA, ARP Timeout 04:00:00
 Last input 00:04:42, output 00:00:01, output hang never
 Last clearing of "show interface" counters 19:00:54
 Input queue:0/75/22087/0 (size/max/drops/flushes); Total output drops:0

```

(display text omitted)

## VIP2 in Cisco 7000 Series or Cisco 7500 Series Routers

Following is an example of the **show interfaces** command used with the VIP2. In this example, the five ethernet interfaces (0 to 4) are on a port adapter port adapter slot 0 of a VIP2 in interface processor slot 3; also, most of the status information for each interface is omitted. (Interfaces are administratively shut down until you enable them.)

```
Router# show interfaces ethernet 3/0/0
Ethernet3/0/1 is administratively down, line protocol is down
 Hardware is cyBus Ethernet, address is 0000.0ca5.2300 (bia 0000.0ca5.2389)
 MTU 1500 bytes, BW 10000 Kbit, DLY 1000 usec, rely 255/255, load 1/255
 Encapsulation ARPA, loopback not set, keepalive set (10 sec)
[Additional display text omitted from this example]
```

```
Router# show interfaces ethernet 3/0/1
Ethernet3/0/2 is administratively down, line protocol is down
 Hardware is cyBus Ethernet, address is 0000.0ca5.2301 (bia 0000.0ca5.238a)
 MTU 1500 bytes, BW 10000 Kbit, DLY 1000 usec, rely 255/255, load 1/255
 Encapsulation ARPA, loopback not set, keepalive set (10 sec)
[Additional display text omitted from this example]
```

```
Router# show interfaces ethernet 3/0/2
Ethernet3/0/3 is administratively down, line protocol is down
 Hardware is cyBus Ethernet, address is 0000.0ca5.2302 (bia 0000.0ca5.238b)
 MTU 1500 bytes, BW 10000 Kbit, DLY 1000 usec, rely 255/255, load 1/255
 Encapsulation ARPA, loopback not set, keepalive set (10 sec)
[Additional display text omitted from this example]
```

```
Router# show interfaces ethernet 3/0/3
Ethernet3/0/3 is administratively down, line protocol is down
 Hardware is cyBus Ethernet, address is 0000.0ca5.2303 (bia 0000.0ca5.238c)
 MTU 1500 bytes, BW 10000 Kbit, DLY 1000 usec, rely 255/255, load 1/255
 Encapsulation ARPA, loopback not set, keepalive set (10 sec)
[Additional display text omitted from this example]
```

```
Router# show interfaces ethernet 3/0/4
Ethernet3/0/4 is administratively down, line protocol is down
 Hardware is cyBus Ethernet, address is 0000.0ca5.2304 (bia 0000.0ca5.238d)
 MTU 1500 bytes, BW 10000 Kbit, DLY 1000 usec, rely 255/255, load 1/255
 Encapsulation ARPA, loopback not set, keepalive set (10 sec)
[Additional display text omitted from this example]
```

Following is an example of the **show interfaces ethernet** command, which shows all of the information specific to interface 0 on a port adapter in port adapter slot 1 of a VIP2 in interface processor slot 3.

```
Router# show interfaces ethernet 3/1/0
Ethernet3/1/0 is administratively down, line protocol is down
 Hardware is cyBus Ethernet, address is 0000.0ca5.2305 (bia 0000.0ca5.238e)
 MTU 1500 bytes, BW 10000 Kbit, DLY 1000 usec, rely 255/255, load 1/255
 Encapsulation ARPA, loopback not set, keepalive set (10 sec)
 ARP type: ARPA, ARP Timeout 4:00:00
 Last input never, output never, output hang never
 Last clearing of "show interface" counters 2:56:26
 Output queue 0/40, 0 drops; input queue 0/75, 0 drops
 5 minute input rate 0 bits/sec, 0 packets/sec
 5 minute output rate 0 bits/sec, 0 packets/sec
 0 packets input, 0 bytes, 0 no buffer
 Received 0 broadcasts, 0 runts, 0 giants
 0 input errors, 0 CRC, 0 frame, 0 overrun, 0 ignored, 0 abort
 0 input packets with dribble condition detected
 0 packets output, 0 bytes, 0 underruns
```

```
0 output errors, 0 collisions, 0 interface resets, 0 restarts
0 output buffer failures, 0 output buffers swapped out
```

Proceed to the next section [“Using the ping Command to Verify Network Connectivity”](#) to check network connectivity of the PA-5EFL and switch or router.

## Using the ping Command to Verify Network Connectivity

Using the `ping` command, you can verify that an interface port is functioning properly. This section provides a brief description of this command. Refer to the publications listed in the [“Related Documentation” section on page vi](#) for detailed command descriptions and examples.

The `ping` command sends echo request packets out to a remote device at an IP address that you specify. After sending an echo request, the system waits a specified time for the remote device to reply. Each echo reply is displayed as an exclamation point (!) on the console terminal; each request that is not returned before the specified timeout is displayed as a period (.). A series of exclamation points (!!!!!) indicates a good connection; a series of periods (.....) or the messages [timed out] or [failed] indicate a bad connection.

Following is an example of a successful `ping` command to a remote server with the address 10.0.0.10:

```
Router# ping 10.0.0.10 <Return>
Type escape sequence to abort.
Sending 5, 100-byte ICMP Echoes to 10.0.0.10, timeout is 2 seconds:
!!!!!
Success rate is 100 percent (5/5), round-trip min/avg/max = 1/15/64 ms
Router#
```

If the connection fails, verify that you have the correct IP address for the destination and that the device is active (powered on), and repeat the `ping` command.

Proceed to the next section [“Using loopback Commands”](#) to finish checking network connectivity.

## Using loopback Commands

With the loopback test you can detect and isolate equipment malfunctions by testing the connection between the PA-5EFL interface and a remote device such as a modem or a CSU/DSU. The `loopback` subcommand places an interface in loopback mode, which enables test packets that are generated from the `ping` command to loop through a remote device or compact serial cable. If the packets complete the loop, the connection is good. If not, you can isolate a fault to the remote device or compact serial cable in the path of the loopback test.

Depending on the mode of the port, issuing the `loopback` command checks the following path:

- When no compact serial cable is attached to the PA-5EFL interface port, or if a DCE cable is attached to a port that is configured as line protocol up, the `loopback` command tests the path between the network processing engine and the interface port only (without leaving the network processing engine and port adapter).
- When a DTE cable is attached to the port, the `loopback` command tests the path between the network processing engine and the near (network processing engine) side of the DSU or modem to test the PA-5EFL interface and compact serial cable.

