



Cisco Performance Routing Engine (ESR-PRE2) Upgrade Installation

First Published: December 28, 2004

Last Updated: February 22, 2011

Document Revision History

The Document Revision History table below records technical changes to this document. The table shows the document revision number for the change, the date of the change, and a brief summary of the change. Note that not all Cisco documents use a Document Revision History table.

Revision	Date	Change Summary
OL-24535-01	February 22, 2011	Moved document to online only and updated format.
78-16710-01	December 28, 2004	Initial publication.

Contents

- [Description, page 2](#)
- [Upgrading to a PRE2, page 2](#)
- [Troubleshooting, page 5](#)
- [Technical Specifications, page 6](#)
- [Related Documentation, page 6](#)
- [Obtaining Documentation and Submitting a Service Request, page 7](#)



Americas Headquarters:
Cisco Systems, Inc., 170 West Tasman Drive, San Jose, CA 95134-1706 USA

**Warning**

Only trained and qualified personnel should be allowed to install, replace, or service this equipment.
Statement 1030

**Caution**

Always wear a grounding wrist strap to avoid ESD damage to the module.

Description

The Cisco Performance Routing Engine (ESR-PRE2) is a single-slot module that performs Layer 2 and Layer 3 packet routing and forwarding using Parallel eXpress Forwarding (PXF).

Upgrading to a PRE2

This upgrade should be performed by a qualified engineer who is familiar with the Cisco router console interface.

Upgrade Considerations

- This is a service-impacting hardware upgrade. The router will not be available for user traffic during the upgrade, and traffic cannot resume until the upgrade is complete.
- PREs or PRE1s cannot operate with a PRE2 in the same chassis and should never be installed in a chassis together.
- PRE2 modules to be installed must have the helper image (eboot) stored in the onboard boot flash, no configuration, and must be set to boot into ROMMON. Individual PRE2 modules ship in this state.
- The new PRE2 image must exist on the TFTP server.

Saving the Startup and Running Configuration Information

When the PRE or PRE1 is removed from the chassis, any local configuration is lost. You must save your configuration information to the TFTP server or media card before removing the module.

If you plan to use the media card from your current PRE or PRE1, you can save your startup configuration, running configuration, and the latest PRE2 image (from the TFTP server) to the media card.

Saving to a Media Card

-
- Step 1** Connect the console to the primary PRE or PRE1.
- Step 2** Copy the startup configuration and running configuration to the existing removable media card.
- Step 3** Download the full PRE2 image from the TFTP server to the media card.
- Step 4** If you have a redundant PRE or PRE1, save this information on the redundant PRE or PRE1 media card.

- Step 5** Remove the media cards from the modules and set them aside.
-

Saving to the TFTP Server

- Step 1** Connect to the primary PRE or PRE1 console.
- Step 2** Save the startup configuration and running configuration to the TFTP server.
-

Removing the PRE or PRE1 Module



Note

Modules can be hot-swapped. However, removing a module terminates all traffic. We recommend that you power down the router to ensure a successful installation.



Warning

Hazardous voltage or energy is present on the backplane when the system is operating. Use caution when servicing. Statement 1034

- Step 1** Ensure that you are properly grounded.
- Step 2** Power down the router
- Step 3** Disconnect the cables from the PRE/PRE1.
- Step 4** Unscrew the captive screws.
- Step 5** Simultaneously pivot both ejector levers away from each other to disengage the module from the backplane.
- Step 6** Slide the PRE/PRE1 out of the slot and place it on an anti-static surface or in an anti-static bag.
- Step 7** If you are replacing a redundant PRE/PRE1, repeat [Step 3](#) through [Step 6](#).
-

Installing a PRE2 Module



Note

To ensure proper operation, always install a single PRE2 in slot A. If you are installing a redundant PRE2 in slot B, wait until after you have installed and configured the primary PRE2 in slot A.

Equipment

ESD wrist strap
Replacement PRE2 modules

- Step 1** Ensure that you are properly grounded.
-

- Step 2** Inspect the connectors on both the PRE2 and the backplane. Bent or broken pins can cause a system malfunction.
- Step 3** Carefully align the PRE2 module with the guides in slot A in the chassis.
- Step 4** Slide the module into the slot until you can feel it seat in the backplane.

Figure 1 Cisco uBR10012 Router

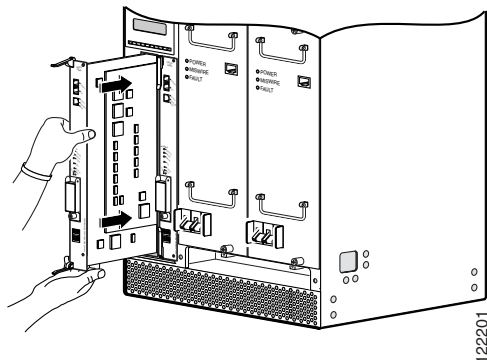
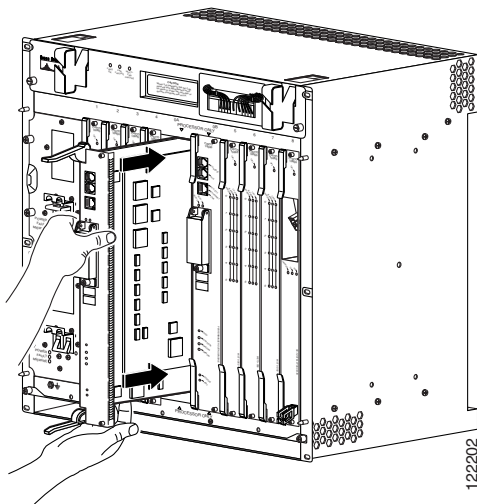

Figure 2 Cisco ESR10000 Router



- Step 5** Simultaneously close the ejector levers to firmly seat the PRE2 in the backplane.
- Step 6** Tighten the captive screws.
- Step 7** Reconnect all the cables to the PRE2 and connect to the console.
- Step 8** If you saved files to the old media card, replace the new media card with the old media card.
- Step 9** Power on the router. The PRE2 cycles through its power-on self-test. The FAIL LED stays on briefly, goes off, and then boots into ROMMON mode.
- Step 10** Boot the full image (if available) from the media card or from the TFTP server.

If the full image is not available, boot the helper image from the onboard boot flash. After booting the router prompts for an initial configuration dialog.

Step 11 If you need to access the TFTP server to obtain the full image or the saved configuration files, enter the configuration dialog and provide the information necessary to access the TFTP server.

If you booted the full image, restore the startup configuration and running configuration information, and set the boot variable for the new image. The upgrade is now complete.

If you booted from the helper image, download the full image, restore the startup and running configuration information, set the boot variable to the new image, and reload the router. The upgrade is now complete.

Installing a Redundant PRE2

Step 1 Repeat [Step 1](#) through [Step 8](#) for slot B.

Step 2 From the console ROMMON prompt, set the configuration to boot the full image and reload.

Troubleshooting

The PRE2 goes through a specific LED sequence at startup.

1. The FAIL LED briefly comes on and then goes off, and the STATUS LED starts flashing and progress messages appear on the PRE2 display.
2. IOS RUN appears after a successful bootup.
3. The STATUS LED on the PRE2 turns green.
4. The redundant PRE2 boot sequence is similar, except that the STATUS LED remains off and the final message is IOS STBY, indicating that the PRE2 is in standby state.

If this sequence does not occur, the STATUS LED is off, or the FAIL LED is yellow, check the following:

1. Are the LEDs on other modules on? If not, check for a problem in the power subsystem.
2. If other module's LEDs are on, remove the PRE2 from the slot, check for bent or broken pins on the connectors, and reinsert it. Ensure that there is solid contact with the backplane and that the PRE2 is securely locked in place.
3. Verify the status of the PRE2 module's internal Ethernet interface (ethernet0/0/0). If this internal interface is down, it could indicate that the PRE2 is not fully seated in the slot or that a hardware failure has occurred. Do not confuse the PRE2 internal Ethernet interface (**ethernet 0/0/0**) with the module's external Fast Ethernet interface (**fastethernet 0/0/0**), which is used for network management and remote access.

[Table 1](#) provides LED status details for PRE2.

Table 1 LED and Switch Description

LEDs/Switch	Description
ACTIVITY	Packets are being transmitted and received
Green/Off	No packet activity

Table 1 LED and Switch Description (continued)

LEDs/Switch	Description
LINK Green/Off	Carrier detected; passing traffic No carrier detected; not passing traffic
CRITICAL MAJOR MINOR Off/Yellow	No alarm Alarm condition
STATUS Green/Off	PRE2 is ready. No power to the PRE2, or it is acting as the redundant PRE2
FAIL Off/Yellow	PRE2 is operating properly PRE2 disabled by major failure
PCMCIA slot 0	Flash card in Slot 0 is active
PCMCIA slot 1	Flash card in Slot 1 is active
ACO ¹ switch	Disables the audible alarm

1. Alarm cutoff switch

Technical Specifications

Table 2 lists technical specifications for PRE2.

Table 2 Technical Specifications

Description	Specification
PRE2	ESR-PRE2/R
PRE2 spare	ESR-PRE2=
Weight	8.45 lb (3.84 kg)
Power consumption per module	200 Watts (682.4 btu per hour)

Related Documentation

Cisco uBR10012 Universal Broadband Router Performance Routing Engine Module

http://www.cisco.com/en/US/docs/interfaces_modules/cable/performance_routing_engine/installation/guide/pre5096.html

Cisco uBR10012 Router Release Notes

http://www.cisco.com/en/US/products/hw/cable/ps2209/prod_release_notes_list.html

Regulatory Compliance and Safety Information for the Cisco uBR10012 Universal Broadband Router

<http://www.cisco.com/en/US/docs/cable/cmts/ubr10012/regulatory/compliance/ub10rcsi.html>

Obtaining Documentation and Submitting a Service Request

For information on obtaining documentation, submitting a service request, and gathering additional information, see the monthly *What's New in Cisco Product Documentation*, which also lists all new and revised Cisco technical documentation, at:

<http://www.cisco.com/en/US/docs/general/whatsnew/whatsnew.html>

Subscribe to the *What's New in Cisco Product Documentation* as an RSS feed and set content to be delivered directly to your desktop using a reader application. The RSS feeds are a free service. Cisco currently supports RSS Version 2.0.

Cisco and the Cisco logo are trademarks or registered trademarks of Cisco and/or its affiliates in the U.S. and other countries. To view a list of Cisco trademarks, go to this URL: www.cisco.com/go/trademarks. Third-party trademarks mentioned are the property of their respective owners. The use of the word partner does not imply a partnership relationship between Cisco and any other company. (1110R)

Copyright © 2004-2011, Cisco Systems, Inc. All Rights Reserved.

