



# Configuring the Cisco uBR10-MC5X20S Cable Interface Line Card

OL-3347-03  
August 2003

## Feature Specifications for Configuring the Cisco uBR10-MC5X20S Cable Interface Line Card

### Feature History

Release	Modification
12.2(11)CY	Support for the Cisco uBR10-MC5X20S cable interface line card is introduced on the Cisco uBR10012 universal broadband router.
12.2(15)BC1	Support was introduced for N+1 Redundancy with the Cisco uBR10-MC5X20S cable interface line card and the Cisco RF Switch in the Cisco uBR10012 router chassis.

### Supported Platforms

Cisco uBR10012 universal broadband router

### Supported Standards

The Cisco uBR10-MC5X20S cable interface line card complies with Data-Over-Cable Service Interface Specifications (DOCSIS) and PacketCable. Refer to the [“Additional References” section on page 18](#) for advanced documentation.

### Finding Support Information for Platforms and Cisco IOS Software Images

Use Cisco Feature Navigator to find information about platform support and Cisco IOS software image support. Access Cisco Feature Navigator at <http://www.cisco.com/go/fn>. You must have an account on Cisco.com. If you do not have an account or have forgotten your username or password, click **Cancel** at the login dialog box and follow the instructions that appear.



**Corporate Headquarters:**  
Cisco Systems, Inc., 170 West Tasman Drive, San Jose, CA 95134-1706 USA

Copyright © 2003 Cisco Systems, Inc. All rights reserved.

# Contents

This document describes the Cisco uBR10-MC5X20S cable interface line card used for the Cisco uBR10012 universal broadband router in Cisco IOS Release 12.2(11)CY. The Cisco uBR10-MC5X20S cable interface line card contains five downstream ports and twenty upstream ports configured in five independent Cable Modem Termination System (CMTS) MAC domains. Each domain includes one downstream port and four upstream ports, and the individual domains operate independently of each other.

This document provides the following information:

- [Prerequisites for Configuring the Cisco uBR10-MC5X20S Cable Interface Line Card](#)
- [Restrictions for Configuring the Cisco uBR10-MC5X20S Cable Interface Line Card](#)
- [Information About Configuring the Cisco uBR10-MC5X20S Cable Interface Line Card](#)
- [Restrictions for Configuring the Cisco uBR10-MC5X20S Cable Interface Line Card](#)
- [Information About Configuring the Cisco uBR10-MC5X20S Cable Interface Line Card](#)
- [How to Configure the Cisco uBR10-MC5x20S Cable Interface Line Card](#)
- [How to Monitor and Maintain the Cable Interface Line Card](#)
- [Configuration Examples for the Cisco uBR10-MC5x20S Cable Interface Line Card](#)
- [Additional References](#)
- [Command Reference](#)

## Prerequisites for Configuring the Cisco uBR10-MC5X20S Cable Interface Line Card

The Cisco uBR10-MC5X20S cable interface line card requires the following:

- The Cisco uBR10012 router must be running 12.2(11)CY or later to support the Cisco uBR10-MC5X20S cable interface line card.
- The Cisco uBR10012 router must be using one or two PRE1 processor modules to support the Cisco uBR10-MC5X20S cable interface line card. The PRE module is not supported.
- At least one Timing, Communication, and Control Plus (TCC+) card must be installed and operational in the Cisco uBR10012 router.
- Complete a basic configuration of the Cisco uBR10012 router; this includes, at a minimum, the following tasks:
  - Configure a host name and password for the router.
  - Configure the router to support Internet Protocol (IP) operations.
  - Install and configure at least one WAN adapter to provide backbone connectivity.
  - Install at least one Cisco uBR10-MC5X20S cable interface line card in an appropriate slot of the Cisco uBR10012 chassis. This is described in the [Cisco uBR10-MC5x20S Cable Interface Line Card for the Cisco uBR10012 Series Router](#) document.
  - Bring up the router as described in the “Configuring the Cable Modem Termination System for the First Time” chapter in the [Cisco uBR10012 Universal Broadband Router Software Configuration Guide](#).

- Determine a channel plan for your Cisco uBR10012 router and all of its cable interfaces.
- Verify that your headend site includes all necessary servers to support DOCSIS and Internet connectivity, including DHCP, ToD, and TFTP servers.

The Cisco uBR10012 router should be operational before beginning the following procedures to configure the Cisco uBR10-MC5X20S cable interface line card.

## Restrictions for Configuring the Cisco uBR10-MC5X20S Cable Interface Line Card

In Cisco IOS Release 12.2(11)CY, the Cisco uBR10-MC5X20S cable interface line card has the following restrictions:

- The Cisco uBR10-MC5X20S cable interface line card requires a PRE1 module running Cisco IOS Release 12.2(11)BC1 or later. If using redundant processors, both processors must be PRE1 modules. You cannot use the Cisco uBR10-MC5X20S cable interface line card with a PRE module.
- When changing the symbol rate on the Cisco uBR10-MC5X20S cable interface line card, the **show controller cable upstream** command may show `US phy SNR_estimate - Unknown` for a brief period of time. Wait a moment and reissue the command to obtain an accurate SNR value.
- The **load-interval** interface configuration command is not supported on the Cisco uBR-MC5X20S cable interface line card, although the command-line interface (CLI) accepts the command for these interfaces.
- The following software features are not supported for the Cisco uBR10-MC5X20S cable interface line card with Cisco IOS Release 12.2(11)CY:
  - Cable Monitor.
  - Point-to-Point Protocol over Ethernet (PPPoE).
  - The Cisco uBR10-MC5X20S cable interface line card includes onboard spectrum management hardware. However, card support for advanced spectrum management features on the Cisco uBR10-MC5X20S cable interface line card will commence with future Cisco IOS releases. Future advanced spectrum management support will include all features currently support available with the uBR-MC16S card.
- The configuration of the downstream and upstream ports is fixed into the five domains that are listed in [Table 2 on page 5](#).
- Each ASIC processor on the Cisco uBR10-MC5X20S interface line card supports two MAC domains. When using the Cisco uBR10012 router and Cisco uBR10-MC5X20S cable interface line card in N+1 Redundancy, MAC domains that share a common ASIC processor must be configured so that they share the same state: Active or Standby. Therefore, MAC domains fail over together.

Downstream MAC domain pairings would be downstream (DS) ports 0 and 1, ports 2 and 3, and port 4. For example, cable 5/0/0 and cable 5/0/1 share the same ASIC processor. Cable 5/0/2 and 5/0/3 share the second ASIC processor, and cable 5/0/4 is on the third ASIC processor, which is not shared.

**Note**

Downstream port 4 is on its own MAC processor. If HCCP is not configured on an interface that shares a MAC processor with another configured interface, it will not failover.

# Information About Configuring the Cisco uBR10-MC5X20S Cable Interface Line Card

The Cisco uBR10-MC5X20S cable interface line card supports downstream and upstream traffic over a Data-over-Cable Service Interface Specification (DOCSIS)-based cable modem network. The card supports 6-MHz National Television Systems Committee (NTSC) channel operation, using standard (STD), Harmonic Related Carrier (HRC), or Incremental Related Carrier (IRC) frequency plans. The card supports downstream channels in the 54 to 860 MHz range and an upstream range of 5 to 42 MHz.



## Note

Although you can use the Cisco uBR10-MC5X20S cable interface line card in 8-MHz international cable plants, the card operates only according to the DOCSIS specifications. This means that the card ignores the upper 2 MHz of available channel width, operates at a maximum bit rate of 5.36 mega-symbols per second, and limits upstream choices to the range below 42 MHz.

The Cisco uBR10-MC5X20S cable interface line card contains five downstream ports and twenty upstream ports. The downstream ports support 64-QAM and 256-QAM, and the upstream ports support QPSK and 16-QAM modulation.

Each downstream port includes an onboard integrated upconverter that generates an RF signal suitable for connection to a combiner and transmission on the coaxial cable network, without the need for any external upconverters. This can save both the money and rack space required by an external upconverter, as well as reduce the complexity of the equipment at the headend site.

The Cisco uBR10-MC5X20S cable interface line card supports all DOCSIS 1.1-specified Annex B radio frequency (RF) data rates, channel widths, and modulation schemes. [Table 1](#) shows the supported DOCSIS data rates.

**Table 1** DOCSIS 1.1 Data Rates

Upstream Channel Width	Modulation Scheme	Baud Rate Sym/sec	Raw Bit Rate Mbit/sec
3.2 MHz	16-QAM QPSK	2.56 M	10.24 5.12
1.6 MHz	16-QAM QPSK	1.28 M	5.12 2.56
800 kHz	16-QAM QPSK	640 K	2.56 1.28
400 kHz	16-QAM QPSK	320 K	1.28 0.64
200 kHz	16-QAM QPSK	160 K	0.64 0.32



## Note

The Cisco IOS software automatically creates modulation profile 21 for the Cisco uBR10-MC5X20S card. This profile cannot be deleted.

The Cisco uBR10-MC5X20S cable interface line card is available with dense connectors. Each type of card contains a color-coded label that identifies the downstream and upstream ports. [Figure 1](#) shows the front panels of each model.

**Figure 1 Cisco uBR10-MC5x20S Cable Interface Line Card Front Panel View (Dense Connectors)**

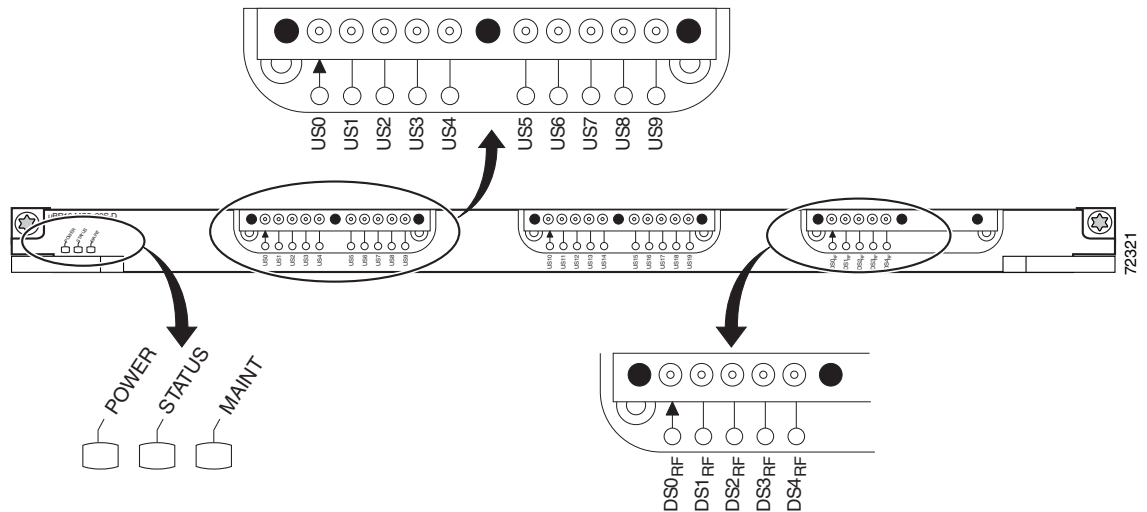

The five downstream ports are labelled DS0 RF through DS4 RF. The RF label indicates that the port is outputting an RF signal from the port’s integrated upconverter. The 20 upstream ports are labelled US0 through US19.

In Cisco IOS Release 12.2(11)CY, each upstream port is statically associated with a particular downstream port. Table 2 shows the association between the Cisco uBR10-MC5X20S cable interface line card’s physical port domains and the upstream and downstream ports associated with each domain. Table 2 also shows the interface label to use when referring to the port when using command-line interface (CLI) commands.

**Table 2 Interface to Port Mapping**

Port Set	Physical Ports	CLI Cable Interface Label <sup>1</sup>
Domain #1	DS0 RF	CX/Y/0
	US0	CX/Y/0 U0
	US1	CX/Y/0 U1
	US2	CX/Y/0 U2
	US3	CX/Y/0 U3
Domain #2	DS1 RF	CX/Y/1
	US4	CX/Y/1 U0
	US5	CX/Y/1 U1
	US6	CX/Y/1 U2
	US7	CX/Y/1 U3
Domain #3	DS2 RF	CX/Y/2
	US8	CX/Y/2 U0
	US9	CX/Y/2 U1
	US10	CX/Y/2 U2
	US11	CX/Y/2 U3

**Table 2** Interface to Port Mapping (continued)

Port Set	Physical Ports	CLI Cable Interface Label <sup>1</sup>
Domain #4	DS3 RF	CX/Y/3
	US12	CX/Y/3 U0
	US13	CX/Y/3 U1
	US14	CX/Y/3 U2
	US15	CX/Y/3 U3
Domain #5	DS4 RF	CX/Y/4
	US16	CX/Y/4 U0
	US17	CX/Y/4 U1
	US18	CX/Y/4 U2
	US19	CX/Y/4 U3

1. The X and Y in the CLI Cable Interface Label column refer to the physical card slot in which the card is installed. The value for X can range from 5 to 8, and the value for Y can be either 0 or 1.

For example, [Table 2](#) shows that if the Cisco uBR10-MC5X20S cable interface line card is installed in slot 5/1, interface C5/1/3 contains domain #4, with downstream port DS3 RF and upstream ports US12, US13, US14, and US15. To configure upstream US14, you would therefore specify upstream U2 on cable interface 5/1/3 (**interface c5/1/3**).

## Benefits of the Cisco uBR10-MC5x20S Cable Interface Line Card

The Cisco uBR10-MC5X20S cable interface line card provides the following benefits:

- Expands the capacity of the Cisco uBR10012 universal broadband router, providing the highest port density available in Cisco cable interface line cards.
- Includes integrated upconverters for each downstream port, removing the requirement for an external upconverter.
- Provides hardware-based support for DOCSIS 1.1 features such as concatenation, fragmentation, and payload headers suppression (PHS).
- Gives cable operators additional flexibility in partitioning the cable plant to address growing subscriber bandwidth demands; enables cost-effective scalability of services and subscribers.
- Supports most earlier Cisco cable interface line card features including online insertion and removal (OIR), allowing key system components to be added or removed without powering off the chassis.
- Interoperates with DOCSIS-compliant cable modems and other RF customer premises equipment (CPE) devices.

# How to Configure the Cisco uBR10-MC5x20S Cable Interface Line Card

The following procedures describe the tasks required to configure the Cisco uBR10-MC5X20S cable interface line card for use in the Cisco uBR10012 universal broadband router chassis.

- [Configuring and Enabling the Cable Interfaces, page 7](#)
- [Shutting Down the Interface, page 12](#)

These procedures provide only the initial, basic configuration for the cable interfaces. For additional and advanced configuration, refer to the “[Additional References](#)” section on [page 18](#).

## Configuring and Enabling the Cable Interfaces

Use the following procedure to configure and enable the downstream and upstream cable interfaces on the Cisco uBR10-MC5X20S cable interface line card.

### SUMMARY STEPS

1. **enable**
2. **configure terminal**
3. **interface** *cableslot/subslot/port*
4. **cable downstream frequency** *down-freq-hz*
5. **cable downstream modulation** { **64qam** | **256qam** }
6. **cable downstream interleave-depth** { **8** | **16** | **32** | **64** | **128** }
7. **cable downstream channel-id** *id*
8. **cable downstream rf-power** *power-level*
9. **no cable downstream rf-shutdown**
10. **no shutdown**
11. **cable upstream** *n* **frequency** *up-freq-hz*  
or  
**cable upstream** *n* **spectrum-group** *group-number*
12. Repeat step 11 for each upstream port.
13. **cable upstream** *n* **power-level** *dbmv*
14. **no cable upstream** *n* **shutdown**
15. Repeat steps 3-13 for each domain.
16. **exit**
17. **copy running-config startup-config**  
or  
**write memory**

## DETAILED STEPS

	Command	Purpose
Step 1	<b>enable</b>  <b>Example:</b> Router> enable	Enables privileged EXEC mode. <ul style="list-style-type: none"> <li>Enter your password if prompted.</li> </ul>
Step 2	<b>configure terminal</b>  <b>Example:</b> Router# config t	Moves to global configuration mode.
Step 3	<b>interface cableslot/subslot/port</b>  <b>Example:</b> Router (config)# interface cable8/1/0	Enters configuration mode for the cable interface where: <p><i>slot/subslot</i> — Physical card slot, where <i>slot</i> can range from 5 to 8, and <i>subslot</i> can be either 0 or 1.</p> <p><i>port</i> — Downstream port for the domain. The <i>port</i> parameter can range from 0 to 4, and the initial domain, domain 1, uses downstream port 0.</p> <p><b>Example:</b> Specifies interface configuration mode for slot 8, subslot 1, and port 0.</p>
Step 4	<b>cable downstream frequency down-freq-hz</b>  <b>Example:</b> Router (config-if)# cable downstream frequency 96000000	Sets the fixed center frequency for the integrated upconverter for this domain's downstream RF carrier in Hz. <p><i>down-freq-hz</i> — The known center frequency of the downstream carrier in Hz, with acceptable range as follows:</p> <ul style="list-style-type: none"> <li>DOCSIS = 88,000,000 to 855,000,000 Hz (88-855 MHz)</li> </ul> <p><b>Note</b> The digital carrier frequency is not the same as the video carrier frequency.</p> <p><b>Example:</b> Sets the cable downstream frequency to 96 MHz.</p>
Step 5	<b>cable downstream modulation { 64qam   256qam }</b>  <b>Example:</b> Router(config-if)# cable downstream modulation 256qam	(Optional) Sets the downstream modulation rate: <p><b>64qam</b> — Modulation rate is 6 bits per downstream symbol (default).</p> <p><b>256qam</b> — Modulation rate is 8 bits per downstream symbol.</p> <p><b>Example:</b> Sets downstream modulation to 256 QAM (8 bits per DS symbol).</p>
Step 6	<b>cable downstream interleave-depth { 8   16   32   64   128 }</b>  <b>Example:</b> Router(config-if)# cable downstream interleave-depth 8	(Optional) Sets the downstream interleave depth, in number of rows of codewords. The default is 32 rows. <p><b>Example:</b> Sets interleave depth to 8 rows.</p>

	Command	Purpose
Step 7	<p><b>cable downstream channel-id</b> <i>id</i></p> <p><b>Example:</b> Router(config-if)# cable downstream channel-id 128</p>	<p>(Optional) Sets the downstream channel ID. The valid range for <i>id</i> is 1 to 254, with the default being the unique unit number that is assigned by the CMTS.</p> <p><i>id</i> — Specifies a downstream channel ID. Valid values are from 0 to 255.</p> <p><b>Example:</b> Sets the downstream channel ID number to 128.</p>
Step 8	<p><b>cable downstream rf-power</b> <i>power-level</i></p> <p><b>Example:</b> Router(config-if)# cable downstream rf-power 45</p>	<p>Sets the RF power output level, in dBmV, on the integrated upconverter.</p> <p><i>power-level</i> — Desired RF output power level in dBmV. The valid range is 45 to 63 dBmV, with a default of 58 dBmV for the Cisco uBR10-MC5X20S cable interface line card.</p> <p><b>Note</b> The official range for acceptable power levels in the DOCSIS specification is 50 to 61 dBmV. Cisco cable interfaces exceed the DOCSIS specification, but power levels outside the DOCSIS specifications should be used only in lab and test environments.</p> <p><b>Example:</b> Sets RF output power level to 45 dBmV.</p>
Step 9	<p><b>no cable downstream rf-shutdown</b></p> <p><b>Example:</b> Router(config-if)# no cable downstream rf-shutdown</p>	<p>Enables RF output on the integrated upconverter.</p>
Step 10	<p><b>no shutdown</b></p> <p><b>Example:</b> Router (config-if)# no shutdown</p>	<p>Activates the downstream port on a cable modem card for digital data transmission over the cable plant.</p>
Step 11	<p><b>cable upstream <i>n</i> frequency <i>up-freq-hz</i></b></p> <p><b>Example:</b> Router (config-int) # cable upstream 3 frequency 5000000</p>	<p>Enters a fixed frequency of the upstream radio frequency (RF) carrier for an upstream port. This sets the center frequency for the upstream in Hz.</p> <p><i>n</i> — Specifies the upstream port number on the cable interface line card for which you want to assign an upstream frequency. Valid values start with 0 for the first upstream port on the cable interface line card. The valid range for <i>port</i> is 0 to 3.</p> <p><i>up-freq-hz</i> — The upstream center frequency is configured to a fixed value. The valid upstream frequency range is 5 MHz (5000000 Hz) to 42 MHz (42000000 Hz) or 65 MHz (65000000 Hz), depending on the cable interface line card being used. If you wish to have the Cisco CMTS dynamically specify a center frequency for the given upstream interface, do not enter any frequency value.</p> <p><b>Example:</b> Assigns an upstream frequency of 50 MHz on port 3.</p>

Command	Purpose
<p>or</p> <p><b>Step 11</b> <b>cable upstream <i>n</i> spectrum-group</b> (cont) <i>group-number</i></p> <p><b>Example:</b> Router (config-int) # cable upstream 0 spectrum-group 12</p>	<p>Assigns the upstream to a spectrum group that defines the valid range of upstream frequencies.</p> <p><i>n</i> — Specifies the upstream port number. Valid values start with 0 for the first upstream port on the cable interface line card. The valid range for <i>port</i> is 0 to 3.</p> <p><i>group-number</i> — Specifies the spectrum group for which you are defining a parameter value, or specifies the number of the spectrum group you wish to remove from your router configuration. Valid range is from 1 to 32.</p> <p><b>Example:</b> Assigns port 0 to upstream spectrum group 12.</p>
<p><b>Step 12</b> Repeat</p>	<p><b>Note</b> Repeat <a href="#">Step 11</a> for each upstream port, changing the <i>port</i> parameter from 0 through 3. You must configure each upstream with either a fixed center frequency or assign it to a spectrum group.</p>
<p><b>Step 13</b> <b>cable upstream <i>n</i> power-level <i>dbmv</i></b></p> <p><b>Example:</b> Router (config-int) # cable upstream 0 power-level -5</p>	<p>(Optional) Sets the input power level for the upstream in dBmV. Optionally repeat this command for each upstream port, changing the <i>port</i> parameter from 0 through 3.</p> <p><i>n</i> — Specifies the upstream port number. Valid values start with 0 for the first upstream port on the cable interface line card. The valid range for <i>port</i> is 0 to 3.</p> <p><i>dbmv</i> — Decibels per millivolt designating the upstream signal input power level. Valid range is -10 dBmV to +25 dBmV. The valid range for <i>dbmv</i> is -10 to +25 dBmV, with a default of 0.</p> <p><b>Example:</b> Sets the input power level for upstream port 0 to -5 dBmV.</p>
<p><b>Step 14</b> <b>no cable upstream <i>n</i> shutdown</b></p> <p><b>Example:</b> Router (config-int) # no cable upstream 0 shutdown</p>	<p>Activates the RF carrier on the upstream port. Each upstream port must be activated to enable upstream data from the cable modems on your network to the Cisco uBR10012 router.</p> <p><i>n</i> — Specifies the upstream port number. Valid values start with 0 for the first upstream port on the cable interface line card. The valid range for <i>port</i> is 0 to 3.</p> <p>Repeat this command for each upstream port, changing the <i>port</i> parameter from 0 through 3.</p> <p><b>Example:</b> Enables the upstream port 0.</p>
<p><b>Step 15</b> Repeat.</p>	<p>Repeat steps 3-13 in this procedure for each domain, changing the downstream port from 0 through 4.</p>

	Command	Purpose
Step 16	<b>exit</b>  <b>Example:</b> Router(config-if)# <b>exit</b>	Exits interface configuration mode, and returns you to global configuration mode.
Step 17	<b>copy running-config startup-config</b> or <b>write memory</b>  <b>Example:</b> Router# <b>copy running-config startup-config</b> or Router# <b>write memory</b>	After configuring all domains, save your settings to the nonvolatile random access memory (NVRAM) to ensure that the system retains the settings after a power cycle

## Examples

The following example shows a typical configuration for the first domain of the card installed in slot 5/0 in the Cisco uBR10012 chassis:

```
Router# config t
Router(config)# interface cable 5/0/0
Router(config-if)# cable downstream frequency 495000000
Router(config-if)# cable downstream modulation 64qam
Router(config-if)# cable downstream interleave-depth 16
Router(config-if)# cable downstream channel-id 129
Router(config-if)# cable downstream rf-power 55
Router(config-if)# no cable downstream rf-shutdown
Router(config-if)# no shutdown
Router(config-if)# cable upstream 0 frequency 30000000
Router(config-if)# cable upstream 0 power-level 3
Router(config-if)# no cable upstream 0 shutdown
Router(config-if)# cable upstream 1 spectrum-group 3
Router(config-if)# cable upstream 0 power-level 3
Router(config-if)# no cable upstream 1 shutdown
Router(config-if)# no cable upstream 2 shutdown
Router(config-if)# no cable upstream 3 shutdown
Router(config-if)# exit
Router(config)# exit
Router# write memory
Router#
```



### Note

For complete descriptions of the above software configuration commands, refer to the publications listed in the [“Additional References”](#) section on page 18.

## Shutting Down the Interface

Before permanently removing a Cisco uBR10-MC5X20S cable interface line card from the Cisco uBR10012 chassis, use the **shutdown** command to shut down and disable the interface. When you shut down an interface, it is designated *administratively down* in the **show** command displays.



### Note

You do not need to shut down an interface when you are replacing the cable interface line card using online insertion and removal (OIR).

Use the following procedure to shut down an interface.

### SUMMARY STEPS

1. **enable**
2. **configure terminal**
3. **interface cableslot/subslot/port**
4. **shutdown**
5. **cable downstream rf-shutdown**
6. Repeat.
7. **exit**
8. **exit**
9. **copy running-config startup-config**

### DETAILED STEPS

	Command	Purpose
Step 1	<b>enable</b>  <b>Example:</b> Router> enable	Enables privileged EXEC mode. <ul style="list-style-type: none"> <li>• Enter your password if prompted.</li> </ul>
Step 2	<b>configure terminal</b>  <b>Example:</b> Router# config t	Moves to global configuration mode.
Step 3	<b>interface cableslot/subslot/port</b>  <b>Example:</b> Router (config)# interface cable8/1/0	Enters configuration mode for the downstream cable interface, where: <p><i>slot/subslot</i> — Physical card slot, where <i>slot</i> can range from 5 to 8, and <i>subslot</i> can be either 0 or 1.</p> <p><i>port</i> — Downstream port for the domain. The <i>port</i> parameter can range from 0 to 4, and the initial domain, domain 1, uses downstream port 0.</p> <p><b>Example:</b> Specifies interface configuration mode for slot 8, subslot 1, and port 0.</p>

	Command	Purpose
Step 4	<b>shutdown</b>  <b>Example:</b> Router(config-if)# <b>shutdown</b>	Shuts down the cable interface line card.
Step 5	<b>cable downstream rf-shutdown</b>  <b>Example:</b> Router(config-if)# <b>cable downstream rf-shutdown</b>	Shuts down the integrated upconverter for the downstream.
Step 6	Repeat.	Repeat steps 3 - 5 for each downstream interface, replacing the <i>port</i> parameter with 0 through 4.
Step 7	<b>exit</b>  <b>Example:</b> Router(config-if)# <b>exit</b>	Exits interface configuration mode.
Step 8	<b>exit</b>  <b>Example:</b> Router(config)# <b>exit</b>	Exits global configuration mode.
Step 9	<b>copy running-config startup-config</b>  <b>Example:</b> Router# <b>copy running-config startup-config</b>	Saves the changes in the permanent configuration file in NVRAM.

**Note**

For complete descriptions of the above software configuration commands, refer to the publications listed in the [“Additional References”](#) section on page 18.

# How to Monitor and Maintain the Cable Interface Line Card

The following sections describe the **show** commands that provide information about the Cisco uBR10-MC5X20S cable interface line card:

- [Verifying a Downstream Port and Integrated Upconverter](#)
- [Verifying the Upstream Port](#)

## Verifying a Downstream Port and Integrated Upconverter

To display the status of a downstream port and its integrated upconverter, use the **show controllers** command in global configuration mode.

### Examples

The following example shows a typical display that shows that the upconverter is enabled and configured for a frequency of 453 MHz.

```
Router# show controllers c7/0/0
Interface Cable6/0/0
Hardware is MC520S
JIB version 60
Cable6/0/0 Upconverter is Enabled Output is Enabled
Model: 74-2094-02 Serial Number: 0WAV05530001 CLEI Code: EAIFBB0BAA
HW Rev: PC2D0108 SW Rev: 007, NVRAM Rev: 006 ECI number 289389
Downstream Frequency 453.0000 MHz
RF Power 55.1 dBmV

idb 0x60E18D30 MAC regs 0x20000000 SDRAM 0x28000000
mac ring entries 32 bandwidth ring entries 128 tx ring entries 128 MAP tx ring entries
128
MAC ring 0xF24F2A0 shadow 0x60E7A538 head 18 count 203634 full 0
Bandwidth ring 0xF24F360 shadow 0x60E7A628 head 117 count 21237 full 0
PCI low priority ring 0xF24F5A0 shadow 0x60E7A898 head 0 count 0 full 0
High priority Tx ring 0xF24EE60 shadow 0x60E7A0C8 head 112 tail 114 count 1161886450 full 0
Low priority Tx ring 0xF24EA20 shadow 0x60E79C58 head 126 tail 0 count 99648 full 0
Timestamp is from local oscillator
throttled 0 enabled 0 disabled 0
Rx: spurious 0 framing_err 0 hcs_err 0 no_buffer 0 short_pkt 0
    no_enqueue 0 no_enp 0 miss_count 0 latency 0
    invalid_sid 0 invalid_mac 0 bad_ext_hdr_pdu 0 concat 0 bad-concat 0
Tx: full 0 drop 0 stuck 0 latency 0
MTx: full 0 drop 0 stuck 0 latency 0
Slots 0 NoUWCollNoEngy 0 FECorHCS 2 HCS 0
Req 0 ReqColl 0 ReqNoise 0 ReqNoEnergy 0
ReqData 0 ReqDataColl 0 ReqDataNoise 0 ReqDataNoEnergy 0
Rng 0 RngColl 0 RngNoise 0
FECBlks 0 UnCorFECBlks 0 CorFECBlks 0
MAP FIFO overflow 0, Rx FIFO overflow 0, No rx buf 0
DS FIFO overflow 0, US FIFO overflow 0, US stuck 0
Bandwidth Requests= 0x1DC0
Piggyback Requests= 0x18A9
Ranging Requests= 0x18530
Timing Offset = 0x0
Bad bandwidth Requests= 0x0
Bad REG_ACK= 0x0
No MAP buffer= 0x0
No REG_RESP buffer= 0x0
Cable6/0/0 Downstream is up
Frequency 453.0000 MHz, Channel Width 6 MHz, 64-QAM, Symbol Rate 5.056941 Msps
FEC ITU-T J.83 Annex B, R/S Interleave I=32, J=4
Downstream channel ID: 0
Dynamic Services Stats:
DSA: 0 REQs 0 RSPs 0 ACKs
0 Successful DSAs 0 DSA Failures
DSC: 0 REQs 0 RSPs 0 ACKs
0 Successful DSCs 0 DSC Failures
DSD: 0 REQs 0 RSPs
0 Successful DSDs 0 DSD Failures
DCC: 0 REQs 0 RSPs 0 ACKs
0 Successful DCCs 0 DCC Failures
```

## Verifying the Upstream Port

To verify the current configuration of an upstream port, use the **show controllers cable** command for the desired upstream port.

```
show controllers cable {slot/port | slot/subslot/port} [downstream | upstream [port]]
```

### Syntax Description

<i>slot/port</i>	Identifies the cable interface and downstream port on the Cisco uBR7246VXR router. <i>slot</i> can range from 3 to 6, and <i>port</i> can be 0 or 1, depending on the cable interface.
<i>slot/subslot/port</i>	Identifies the cable interface on the Cisco uBR10012 router. The following are the valid values: <ul style="list-style-type: none"> <li>slot = 5 to 8</li> <li>subslot = 0 or 1</li> <li>port = 0 to 4 (depending on the cable interface)</li> </ul>
<b>downstream</b>	(Optional) Displays downstream interface status.
<b>upstream</b>	(Optional) Displays upstream interface status.
<i>port</i>	(Optional) Specifies the desired upstream port. Valid values start with 0 for the first upstream port on the cable interface line card.

### Examples

The following example shows a typical display that shows that the upstream is configured for a frequency of 6.0 Mhz, with a channel width of 1.6 MHz and 16-QAM modulation.

```
Router# show controllers cable5/0/0 upstream 0
Cable6/0/0 Upstream 0 is up
Frequency 6.000 MHz, Channel Width 1.600 MHz, 16-QAM Symbol Rate 1.280 Msps
Spectrum Group is overridden
SNR - Unknown - no modems online.
Nominal Input Power Level 0 dBmV, Tx Timing Offset 0
Ranging Backoff automatic (Start 0, End 3)
Ranging Insertion Interval automatic (60 ms)
Tx Backoff Start 0, Tx Backoff End 4
Modulation Profile Group 1
Concatenation is enabled
Fragmentation is enabled
part_id=0x0952, rev_id=0x00, rev2_id=0x00
nb_agc_thr=0x0000, nb_agc_nom=0x0000
Range Load Reg Size=0x58
Request Load Reg Size=0x0E
Minislot Size in number of Timebase Ticks is = 8
Minislot Size in Symbols = 64
Bandwidth Requests = 0x0
Piggyback Requests = 0x0
Invalid BW Requests= 0x0
Minislots Requested= 0x0
Minislots Granted = 0x0
Minislot Size in Bytes = 32
Map Advance (Dynamic) : 2180 usecs
UCD Count = 54528
```



#### Note

The upstream frequency displayed by the **show controllers cable** command output might not exactly match the frequency configured with the **cable upstream frequency** command, because Cisco cable interface line cards use frequencies in 16 KHz increments. For example, if you specify a frequency of 27 MHz, the upstream is programmed for a center frequency of 27.008 MHz, which is the next highest 16-KHz boundary.

# Configuration Examples for the Cisco uBR10-MC5x20S Cable Interface Line Card

This section provides a typical configuration for the Cisco uBR10-MC5X20S cable interface line card.

## Example of Cisco uBR10012 Router with Single Cisco uBR10-MC5x20S Cable Interface Line Card

The following is a portion of the configuration file for the Cisco uBR10012 router with a single Cisco uBR10-MC5X20S cable interface line card:

```
interface Cable5/0/0
 ip address 10.20.71.1 255.255.255.0
 cable helper-address 10.20.71.12
 cable downstream annex B
 cable downstream modulation 64qam
 cable downstream interleave-depth 32
 no cable downstream rf-shutdown
!
 cable upstream 0 frequency 11000000
 cable upstream 0 power-level 0
 no cable upstream 0 shutdown
!
 cable upstream 1 frequency 32000000
 cable upstream 1 power-level 0
 no cable upstream 1 shutdown
!
 cable upstream 2 frequency 26006000
 cable upstream 2 power-level 0
 no cable upstream 2 shutdown
!
 cable upstream 3 frequency 7808000
 cable upstream 3 power-level 0
 cable upstream 3 channel-width 800000
 no cable upstream 3 shutdown
 cable helper-address 10.80.93.100
!
interface Cable5/0/1
 ip address 10.30.71.1 255.255.255.0
 ip helper-address 10.20.71.12
 cable downstream annex B
 cable downstream modulation 64qam
 cable downstream interleave-depth 32
 no cable downstream rf-shutdown
!
 cable upstream 0 frequency 10000000
 cable upstream 0 power-level 0
 no cable upstream 0 shutdown
!
 cable upstream 1 frequency 30000000
 cable upstream 1 power-level 0
 no cable upstream 1 shutdown
!
 cable upstream 2 frequency 26000000
 cable upstream 2 power-level 0
 no cable upstream 2 shutdown
!
 cable upstream 3 frequency 7004000
 cable upstream 3 power-level 0
 cable upstream 3 channel-width 800000
 no cable upstream 3 shutdown
 cable helper-address 10.80.93.100
!
interface Cable5/0/2
 ip address 10.40.71.1 255.255.255.0
 ip helper-address 10.20.71.12
 cable downstream annex B
```

```
cable downstream modulation 64qam
cable downstream interleave-depth 32
no cable downstream rf-shutdown
!
cable upstream 0 frequency 10000000
cable upstream 0 power-level 0
no cable upstream 0 shutdown
!
cable upstream 1 frequency 30000000
cable upstream 1 power-level 0
no cable upstream 1 shutdown
!
cable upstream 2 frequency 22000000
cable upstream 2 power-level 0
no cable upstream 2 shutdown
!
cable upstream 3 frequency 7108000
cable upstream 3 power-level 0
cable upstream 3 channel-width 800000
no cable upstream 3 shutdown
cable helper-address 10.80.93.100
!
interface Cable5/0/3
ip address 10.50.71.1 255.255.255.0
ip helper-address 10.20.71.12
cable downstream annex B
cable downstream modulation 64qam
cable downstream interleave-depth 32
no cable downstream rf-shutdown
!
cable upstream 0 frequency 10000000
cable upstream 0 power-level 0
no cable upstream 0 shutdown
!
cable upstream 1 frequency 30000000
cable upstream 1 power-level 0
no cable upstream 1 shutdown
!
cable upstream 2 frequency 24000000
cable upstream 2 power-level 0
no cable upstream 2 shutdown
!
cable upstream 3 frequency 42000000
cable upstream 3 power-level 0
cable upstream 3 channel-width 3200000
no cable upstream 3 shutdown
cable helper-address 10.80.93.100
!
interface Cable5/0/4
ip address 10.60.71.1 255.255.255.0
ip helper-address 10.20.71.12
cable downstream annex B
cable downstream modulation 64qam
cable downstream interleave-depth 32
no cable downstream rf-shutdown
!
cable upstream 0 frequency 10000000
cable upstream 0 power-level 0
no cable upstream 0 shutdown
!
cable upstream 1 frequency 30000000
cable upstream 1 power-level 0
no cable upstream 1 shutdown
!
cable upstream 2 frequency 20000000
cable upstream 2 power-level 0
no cable upstream 2 shutdown
!
cable upstream 3 frequency 7008000
cable upstream 3 power-level 0
cable upstream 3 channel-width 800000
no cable upstream 3 shutdown
cable helper-address 10.80.93.100
```

# Additional References

For more information, refer to the following documents on Cisco.com or the Documentation CD-ROM:

## Related Documents

Related Topic	Document Title
Cisco uBR10012 Router Installation and Configuration	<ul style="list-style-type: none"> <li>• <i>Cisco uBR10012 Universal Broadband Router Hardware Installation Guide</i> <a href="http://www.cisco.com/univercd/cc/td/doc/product/cable/ubr10k/ubr10012/hig/index.htm">http://www.cisco.com/univercd/cc/td/doc/product/cable/ubr10k/ubr10012/hig/index.htm</a></li> <li>• <i>Cisco uBR10012 Universal Broadband Router Software Configuration Guide</i> <a href="http://www.cisco.com/univercd/cc/td/doc/product/cable/ubr10k/ubr10012/scg/index.htm">http://www.cisco.com/univercd/cc/td/doc/product/cable/ubr10k/ubr10012/scg/index.htm</a></li> <li>• <i>Cisco uBR10012 Universal Broadband Router Software Features</i> <a href="http://www.cisco.com/univercd/cc/td/doc/product/cable/ubr10k/ubr10012/ub10ksw/index.htm">http://www.cisco.com/univercd/cc/td/doc/product/cable/ubr10k/ubr10012/ub10ksw/index.htm</a></li> <li>• <i>Cisco uBR10000 Series Universal Broadband Router Release Notes</i> <a href="http://www.cisco.com/univercd/cc/td/doc/product/cable/ubr10k/ubr10krns/index.htm">http://www.cisco.com/univercd/cc/td/doc/product/cable/ubr10k/ubr10krns/index.htm</a></li> <li>• <i>Cisco Cable Modem Termination System Feature Guide</i> <a href="http://www.cisco.com/univercd/cc/td/doc/product/cable/cab_rout/cmtsfg/index.htm">http://www.cisco.com/univercd/cc/td/doc/product/cable/cab_rout/cmtsfg/index.htm</a></li> </ul>
Cisco uBR10-MC5x20S Cable Interface Line Card Installation	<ul style="list-style-type: none"> <li>• <i>Cisco uBR10-MC5X20S Cable Interface Line Card</i> <a href="http://www.cisco.com/en/US/products/hw/cable/ps2209/prod_module_installation_guide09186a008019e0bc.html">http://www.cisco.com/en/US/products/hw/cable/ps2209/prod_module_installation_guide09186a008019e0bc.html</a></li> <li>• <i>Installing the Cisco uBR10- MC5X20S Cable Interface Line Card - Quick Start</i> <a href="http://www.cisco.com/application/pdf/en/us/guest/products/ps2209/c1616/ccmigration_09186a008015bce1.pdf">http://www.cisco.com/application/pdf/en/us/guest/products/ps2209/c1616/ccmigration_09186a008015bce1.pdf</a></li> </ul>
High Availability (N+1 Redundancy)	<ul style="list-style-type: none"> <li>• <i>N+1 Tips and Configuration for the Cisco uBR10012 Router with the Cisco uBR10-MC5x20S Cable Interface Line Card</i> (document availability August, 2003) <a href="http://www.cisco.com/en/US/products/hw/cable/ps2209/prod_tech_notes_list.html">http://www.cisco.com/en/US/products/hw/cable/ps2209/prod_tech_notes_list.html</a></li> <li>• <i>Cisco CMTS Feature Guide: “N+1 Redundancy for the Cisco Cable Modem Termination System”</i> (document update August, 2003) <a href="http://www.cisco.com/univercd/cc/td/doc/product/cable/cab_rout/cmtsfg/ufgnpls1.htm">http://www.cisco.com/univercd/cc/td/doc/product/cable/cab_rout/cmtsfg/ufgnpls1.htm</a></li> </ul>
Spectrum Management	<p>You must also assign modulation profiles to each upstream interface and define the spectrum management characteristics, following general spectrum management configuration guidelines contained in this document:</p> <ul style="list-style-type: none"> <li>• <i>Cisco CMTS Feature Guide: “Spectrum Management for the Cisco CMTS”</i> <a href="http://www.cisco.com/univercd/cc/td/doc/product/cable/cab_rout/cmtsfg/ufg_spec.htm">http://www.cisco.com/univercd/cc/td/doc/product/cable/cab_rout/cmtsfg/ufg_spec.htm</a></li> </ul> <p><b>Note</b> This chapter also describes the intelligent and advanced spectrum management features that are not supported in Cisco IOS Release 12.2(11)CY for the Cisco uBR10-MC5X20S cable interface line card.</p>

## Standards

### Standards

- DOCSIS ITU J.112 standard and ITU J.83 Annex B
- CableLabs ECR; RFI-R-98036

## MIBs

No new or modified MIBs are supported by this feature.

To obtain lists of supported MIBs by platform and Cisco IOS release, and to download MIB modules, go to the Cisco MIB website on Cisco.com at the following URL:

<http://www.cisco.com/public/sw-center/netmgmt/cmtk/mibs.shtml>

## RFCs

No new or modified RFCs are supported by this feature.

## Technical Assistance

Description	Link
Technical Assistance Center (TAC) home page, containing 30,000 pages of searchable technical content, including links to products, technologies, solutions, technical tips, and tools. Registered Cisco.com users can log in from this page to access even more content.	<a href="http://www.cisco.com/public/support/tac/home.shtml">http://www.cisco.com/public/support/tac/home.shtml</a>

# Command Reference

This section describes the following new and changed commands that configure and monitor the Cisco uBR10-MC5X20S cable interface line card:

- [cable downstream rf-power, page 21](#)
- [cable downstream rf-shutdown, page 22](#)
- [show hardware pxf cable, page 23](#)
- [show interface cable sid, page 26](#)

**Note**

---

Cable configuration commands are described in the *Cisco Broadband Cable Command Reference Guide*.

---

# cable downstream rf-power

To set the RF power output level on an integrated upconverter on the Cisco uBR10012 universal broadband router or the Cisco uBR10-MC5X20S cable interface line card, use the **cable downstream rf-power** command in cable interface configuration mode. To reset the RF output power level to its default value, use the **no** form of this command.

```
cable downstream rf-power power-level
no cable downstream rf-power
```

<b>Syntax Description</b>	<i>power-level</i>	Desired RF output power level in dBmV. The valid range is 45 to 63 dBmV.
	<b>Note</b>	The official range for acceptable power levels in the DOCSIS specification is 50 to 61 dBmV. Cisco cable interfaces exceed the DOCSIS specification, but power levels outside the DOCSIS specifications should be used only in lab and test environments.

<b>Defaults</b>	50 dBmV for the Cisco uBR10012 universal broadband router 58 dBmV for the Cisco uBR10-MC5X20S cable interface line card on the Cisco uBR10012 router
-----------------	---

<b>Command Modes</b>	Interface configuration (cable interface only)
----------------------	--

Command History	Release	Modification
	12.2(11)CY	Support was added for the Cisco uBR10-MC5X20S cable interface line card on the Cisco uBR10012 universal broadband router.
	12.1(5)EC1	This command was introduced to provide support on the integrated upconverter on the Cisco uBR7100 series universal broadband router.

**Examples** The following example shows the first integrated upconverter on a Cisco uBR10012 router being configured for an RF output power level of 55 dBmV:

```
router(config)# cable interface 5/1/0
router(config-if)# cable downstream rf-power 55
```

The following commands shows the first integrated upconverter being set to the default power level of 58 dBmV on the Cisco uBR10012 router:

```
router(config)# cable interface 5/1/0
router(config-if)# no cable downstream rf-power
```

Related Commands	Command	Description
	<a href="#">cable downstream frequency</a>	Configures the downstream center frequency on the integrated upconverter.
	<a href="#">cable downstream rf-shutdown</a>	Enables or disables the RF output from the integrated upconverter.
	<a href="#">debug cable upconverter</a>	Enables debugging of the internal upconverter operation.
	<a href="#">show controllers cable</a>	Displays status and configuration information for the cable interface.

# cable downstream rf-shutdown

To disable the RF output from an integrated upconverter on the Cisco uBR10012 universal broadband router or the Cisco uBR10-MC5X20S cable interface line card, use the **cable downstream rf-shutdown** command in cable interface configuration mode. To enable the RF output on the integrated upconverter, use the **no** form of this command.

**cable downstream rf-shutdown**  
**no cable downstream rf-shutdown**

**Syntax Description** This command has no arguments or keywords.

**Defaults** RF output is disabled.

**Command Modes** Interface configuration mode (cable interface only)

Command History	Release	Modification
	12.1(5)EC1	This command was introduced to provide support on the integrated upconverter on the Cisco uBR7100 series router.
	12.2(11)CY	Support was added for the Cisco uBR10-MC5X20S cable interface line card on the Cisco uBR10012 router.

**Usage Guidelines** By default, the integrated upconverter on the Cisco uBR10012 universal broadband router and the Cisco uBR10-MC5X20S cable interface line card is disabled, and the downstream port does not output any signal. The **no** form of this command enables the integrated upconverter, allowing it to output an RF signal through the downstream port.

However, before a valid DOCSIS downstream signal can be output, the following must also be done:

- A valid downstream RF frequency must be configured using the **cable downstream frequency** cable interface command.
- The cable interface must be enabled using the **no shutdown** command on the cable interface.



**Note**

This command does not affect the IF output from the DS0 downstream port on the Cisco uBR10012 universal broadband router. The Cisco uBR10-MC5X20S cable interface line card does not provide IF output for its downstream ports.

**Examples** The following example enables the second integrated upconverter on the Cisco uBR10012 router:

```
router(config)# cable interface 7/0/1
router(config-if)# no cable downstream rf-shutdown
```

The following commands must also be given before the DS0 RF port can transmit a valid RF signal:

```
router(config-if)# cable downstream frequency center-frequency
router(config-if)# no shutdown
router(config-if)# exit
router(config)#
```

Related Commands	Command	Description
	<a href="#">cable downstream frequency</a>	Configures the downstream center frequency on the integrated upconverter.
	<a href="#">cable downstream rf-power</a>	Configures the desired RF output power on the integrated upconverter.
	<a href="#">debug cable upconverter</a>	Enables debugging of the internal upconverter operation.
	<a href="#">show controllers cable</a>	Displays status and configuration information for the cable interface.

# show hardware pxf cable

To display information about the multicast echo and packet intercept features for one or all cable interfaces, use the **show hardware pxf cable** command in Privileged EXEC mode.

```
show hardware pxf cable {feature-table [cx/y/z] | multicast-echo ds-group |
multicast-echo mcast-addr}
```

## Syntax Description

<b>feature-table</b> [cx/y/z]	Displays the multicast echo and packet intercept status on the PXF processor. If given without any options, displays the status for all cable interfaces and subinterfaces. If given with an optional cable interface, displays the status for that particular interface.
<b>multicast-echo ds-group</b>	Displays the cable interfaces that are associated with each downstream group, where each downstream group is a unique DOCSIS MAC domain. (Interfaces that are bundled together are considered one MAC domain.)
<b>multicast-echo</b> <i>mcast-addr</i>	Displays the service flow ID (SFID) for a particular multicast address.

## Defaults

No default behavior or values.

## Command Modes

Privileged EXEC

## Command History

Release	Modification
12.2(11)CY	This command was introduced for the Cisco uBR10012 router.

## Usage Guidelines

The **show hardware pxf cable** command displays information about whether multicast echo and packet intercept are enabled on the cable interfaces. It can also be used to display the service flow ID (SFID) used for each multicast address that is being processed by the router.

## Examples

The following example shows a typical display for the **show hardware pxf cable feature-table** command for all cable interfaces:

```
Router# show hardware pxf cable feature-table

Interface      VCCI   McastEcho  Intercept  DSGroup  InterceptGroup
Cable5/0/0     3      On          On         0         0
Cable5/0/0.1   9      On          On         0         0
Cable5/0/1     4      On          Off        255      -
Cable6/0/0     5      On          Off        255      -
Cable6/0/1     6      On          Off        255      -
Cable7/0/0     7      On          Off        1         -
Cable7/0/1     8      On          Off        2         -

Router#
```

The following example shows a typical display for the **show hardware pxf cable feature-table** option for a particular cable interface:

```
Router# show hardware pxf cable feature-table c5/0/0

Interface      VCCI    McastEcho  Intercept  DSGroup  InterceptGroup
Cable5/0/0     3       On         On         0         0
Cable5/0/0.1   9       On         On         0         0

Router#
```

[Table 3](#) describes the fields shown by both forms of the **show hardware pxf cable feature-table** command:

**Table 3** *show hardware pxf cable feature-table Field Descriptions*

Field	Description
Interface	Identifies the cable interface or subinterface.
VCCI	Displays the Virtually Cool Common Index (VCCI) for this cable interface or subinterface. The VCCI is an index that uniquely identifies every interface or subinterface on the PXF processor, and that quickly maps that interface to the appropriate set of services and features.
McastEcho	Displays whether multicast echo is enabled (On) or disabled (Off).
Intercept	Displays whether packet intercept, as per the Communications Assistance of Law Enforcement Act (CALEA), is enabled (On) or disabled (Off).
DSGroup	Displays the downstream group (unique MAC domain) that is associated with this interface or subinterface. Interfaces that are bundled together are considered one MAC domain.
InterceptGroup	Displays the intercept packet group assigned to this cable interface.

The following example shows a typical display for the **show hardware pxf cable multicast-echo ds-group** command, listing each downstream multicast group and its associated cable interface:

```
Router# show hardware pxf cable multicast-echo ds-group

DS Group      Interface
0             Cable5/0/0
1             Cable7/0/0
2             Cable7/0/1

Router#
```

The following example shows a typical display for the **show hardware pxf cable multicast-echo** command for a particular multicast address:

```
Router# show hardware pxf cable multicast-echo 230.1.1.1

Multicast Address  SFID      DS Jib Header
230.1.1.1         16385     0x0000 0000 1000 0001 1000

Router#
```

[Table 4](#) describes the fields shown by the **show hardware pxf cable multicast-echo** command for a particular multicast address:

**Table 4** *show hardware pxf cable multicast-echo Field Descriptions*

Field	Description
Multicast Address	Identifies the multicast address being displayed.
SFID	Displays the service flow ID (SFID) for this particular multicast address.
DS Jib Header	Shows the bitmask used for this multicast address on the PRE's MAC-layer processor. The bitmask consists of ten hexadecimal bytes in the following format (reading left to right, from most significant to least significant bit): <ul style="list-style-type: none"> <li>• Bytes 9:8 = Specifies the key index for the downstream.</li> <li>• Bytes 7:6 = Identifies the rule number used for packet header suppression (if enabled)</li> <li>• Byte 5 = Bitmask that defines the type of packet transmitted: <ul style="list-style-type: none"> <li>– Bit 4 = 1 if padding CRC for data packets, 0 if not padding the CRC</li> <li>– Bit 3 = 1 if inserting an extended header (EH) for PHS processing</li> <li>– Bit 2 = 1 if inserting an extended header (EH) for BPI+ processing</li> <li>– Bits 1:0 = Specifies the packet type: 00 = Data packet 01 = MAC management message for transmitted packets 10 = Internal MAP message on upstream 11 = Special packet</li> </ul> </li> <li>• Byte 4 = Bitmask that identifies the type of map control and key sequence for the packet: <ul style="list-style-type: none"> <li>– Bits 6:4 = Destination upstream for the MAP message</li> <li>– Bits 3:0 = BPI Key Sequence number</li> </ul> </li> <li>• Bytes 3:2 = Index to obtain the downstream modem statistics.</li> <li>• Byte 1 = Specifies the assumed minimum size of a packet data unit. Multiply this byte by 4 to get the actual minimum size in bytes.</li> <li>• Byte 0 = Specifies the DOCSIS header size, with a maximum value of 0xE0 (248 decimal).</li> </ul>

**Related Commands**

Command	Description
<a href="#">show hardware pxf cpu</a>	Displays the display different statistics about the operation of the CPU processor during PXF processing.
<a href="#">show hardware pxf microcode</a>	Displays identifying information for the microcode being used on the processor.
<a href="#">show hardware pxf timing-wheel</a>	Displays the contents of the wheel counters on the PXF processor.
<a href="#">show hardware pxf xcm</a>	Displays the current state of Error Checking and Correcting (ECC) for the External Column Memory (XCM) on the PXF processor.

## show interface cable sid

To display the service identifier (SID) information for a CM, use the **show interface cable sid** command in privileged EXEC mode.

```
show interface cable {slot/port | slot/subslot/port} sid [association | counters | qos] [verbose]
```

Syntax Description	
<i>slot/port</i>	(Cisco uBR7100 series router only) Identifies the cable interface and downstream port on the Cisco uBR7100 series router and is always <b>1/0</b> .
<i>slot/subslot/port</i>	(Cisco uBR10012 router only) Identifies the cable interface and downstream port on the Cisco uBR10-MC5X20S cable interface line card on the Cisco uBR10012 router. The following are the valid values: <ul style="list-style-type: none"> <li>• <i>slot</i> = 5 to 8</li> <li>• <i>subslot</i> = 0 or 1</li> <li>• <i>port</i> = 0 to 4</li> </ul>
<b>association</b>	Displays the virtual interfaces (VRF) or Interface Descriptor Blocks (IDBs).
<b>connectivity</b>	Displays the values of the per-SID connectivity statistics. This option appears only in DOCSIS 1.0 and 1.0+ releases.
<b>counters</b>	Displays the values of the per-SID usage counters. Same as the keyword <b>stats</b> that appeared in Cisco IOS Release 11.3(5)NA and earlier releases.
<b>qos</b>	Displays the QoS characteristics received by each SID.
<b>verbose</b>	Displays detailed information.

**Command Modes** Privileged EXEC

Command History	Release	Modification
	11.3 XA	This command was introduced.
	11.3(6)NA	The keyword <b>stats</b> was changed to <b>counters</b> .
	12.0(4)XI	The primary SID information was added.
	12.0(5)T	The command output was modified to identify secondary SIDs.
	12.0(7)XR and 12.0(7)T	The <b>verbose</b> keyword was added.
	12.1(4)CX, 12.2(1)XF, and 12.2(4)BC1	The <b>qos</b> keyword was added to display information on the QoS values received by the SID from the MAC scheduler.  Also, the <b>connectivity</b> option was moved to the <b>show cable modem</b> command.
	12.1(11)EC, 12.2(8)BC1	The <b>association</b> keyword was added.
	12.2(11)CY	Three codeword fields were added to the verbose counters display to support the Cisco uBR10-MC5X20S cable interface line card. These fields always display zero for the other cable interface line cards.

**Usage Guidelines**

Data transport over the radio frequency (RF) link uses the registered SID address rather than the Ethernet address. This allows multiple hosts to access the network via a single CM.

The **verbose** keyword can be used with any of the other options or by itself.

**Examples**

The following sample output from the **show interface cable sid** command shows the various forms of the command. Some examples cite the Cisco uBR7200 series platform. The displays on other Cisco CMTS platforms are similar.

```
Router# show interface c4/0 sid
```

Sid	Prim	MAC Address	IP Address	Type	Age	Admin State	Sched Type	Sfid
5		0010.7b6b.58c1	10.20.114.34	stat	2dlh36	menable	BE	1
6		0010.7bed.9dc9	10.20.114.37	stat	2dlh36	menable	BE	13
7		0010.7bed.9dbb	10.20.114.38	stat	2dlh36	menable	BE	15
8		0010.7b6b.58bb	10.20.114.112	stat	2dlh34	menable	BE	17
9		0010.7b6b.58bb	10.20.114.112	dyna	2dlh34	menable	BE	19

```
Router# show interface c4/0 sid qos
```

Sid	Pr	MaxSusRate	MinRsvRate	Sched Type	Grant Size	Grant Intvl	GPI	Poll Intvl	Thruput
5	0	64000	0	BE	0	0	0	0	0
6	0	64000	0	BE	0	0	0	0	0
7	0	64000	0	BE	0	0	0	0	0
8	0	64000	0	BE	0	0	0	0	0

```
Router# show interface c4/0 sid 5 qos
```

Sid	Pr	MaxSusRate	MinRsvRate	Sched Type	Grant Size	Grant Intvl	GPI	Poll Intvl	Thruput
5	0	64000	0	BE	0	0	0	0	0

```
Router# show interface c4/0 sid 5 qos verbose
```

```
Sid : 5
Traffic Priority : 0
Maximum Sustained Rate : 64000
Maximum Burst : 0
Minimum Reserved Rate : 0
Minimum Packet Size : 0
Maximum Concatenated Burst : 1522
Scheduling Type : Best Effort
Nominal Grant Interval : 0
Tolerated Grant Jitter : 0
Nominal Polling Interval : 0
Tolerated Polling Jitter : 0
Unsolicited Grant Size : 0
Grants per Interval : 0
Request/Transmission Policy : 0x0
IP ToS Overwrite [AND-mask, OR-mask] : 0x0, 0x0
Current Throughput : 0 bits/sec, 0 packets/sec
```

```
Router# show interface c5/0 sid counter
```

```
00:02:23: %ENVM-3-LASTENV: Cannot save environmental data
Sid Req-polls BW-reqs Grants Packets Frag Concatpkts
   issued   received issued received complete received
1 0 22 22 22 0 0
2 0 3 3 2 0 0
3 0 0 0 0 0 0
```

The following example shows typical verbose output for the SID counters on a Cisco uBR10-MC5X20S cable interface line card:

```
Router# show interface c4/0 sid 3 counter verbose
```

■ **show interface cable sid**

```
Sid : 3
Request polls issued : 0
BW requests received : 1
No grant buf BW request drops : 0
Rate exceeded BW request drops : 0
Grants issued : 1
Packets received : 0
Bytes received : 0
Fragment reassembly completed : 0
Fragment reassembly incomplete : 0
Concatenated packets received : 0
Queue-indicator bit statistics : 0 set, 0 granted
Good Codewords rx : 0
Corrected Codewords rx : 0
Uncorrectable Codewords rx : 0
```

The following example shows typical **verbose** output for the SID counters on the Cisco uBR10-MC5X20S cable interface line card on the Cisco uBR10012 universal broadband router:

```
Router# show interface cable 6/1/0 sid 3 counters verbose
```

```
Sid : 1
Request polls issued : 0
BWReqs {Cont,Pigg,RPoll,Other} : 0, 1052, 1052, 0
No grant buf BW request drops : 0
Rate exceeded BW request drops : 0
Grants issued : 1052
Packets received : 0
Bytes received : 0
Fragment reassembly completed : 0
Fragment reassembly incomplete : 0
Concatenated packets received : 0
Queue-indicator bit statistics : 0 set, 0 granted
Good Codewords rx : 53
Corrected Codewords rx : 6110
Uncorrectable Codewords rx : 8540896
```

The following example shows typical output for the **association** keyword:

```
Router# show interface cable 5/1/0 sid association
```

Sid	Prim	Online	IP Address	MAC Address	Interface	VRF Name
1		online	195.151.129.20	0003.e38f.e993	Ca5/0.50	green
2		online	195.151.129.17	0003.e38f.e89d	Ca5/0.50	green
3		init(t)	195.151.129.12	00d0.baa2.fb93	Ca5/0.50	green

**Table 5** describes the fields displayed by the **show interface cable sid** command command.

**Table 5** *show interface cable sid Field Descriptions*

Field	Description
Sid	Service identification number.
Prim Sid	The primary service identifier (SID) assigned to the modem.
Type	Indicates that this SID was created statically at the time of registration or dynamically by the exchange of dynamic service messages between the CM and CMTS.
Online State Offline State	“Online” means that the modem owning this SID is processing traffic. “Offline” means that the modem owning this SID is not processing traffic.
Admin Status	“Disable” means that the SID has been turned off. “Enable” is the normal state.
QoS	Quality of service.
Create time	When the SID was created, number of seconds since the system booted.

**Table 5** show interface cable sid Field Descriptions (continued)

Field	Description
Input octets (Inoctets)	Number of octets received by using this SID.
Input packets (Inpackets)	Number of packets received by using this SID.
Output octets (Outoctets)	Number of octets sent from this SID.
Output packets (Outpackets)	Number of packets sent from this SID.
IP address	IP address of the modem owning this SID.
MAC address	MAC address of the modem owning this SID.
BW requests received	Number of bandwidth requests received by this SID.
Grants issued	Number of bandwidth requests granted by this SID.
Rate exceeded BW request drops	Number of bandwidth requests not granted by this SID.
Rate exceeded DS packet drops	Number of downstream packets lost by this SID.
Ratelimit BWReqDrop	Number of bandwidth requests not granted by this SID.
Ratelimit DSPktDrop	Number of downstream packets lost by this SID.
1st time online	Time at which the modem with this SID connected.
Times online	Number of times the modem with this SID connected.
% online	Percentage of time the modem with this SID has been connected.
Online time	The minimum, average, and maximum number of hours and minutes the modem with this SID has been connected.  <b>Note</b> A CM is considered online when it has completed the registration process and has communicated with the DHCP, TFTP, and TOD servers.
Offline time	The minimum, average, and maximum number of hours and minutes the modem with this SID has been disconnected.  <b>Note</b> A CM is considered offline after it has missed 16 consecutive station maintenance messages.
MaxSusRate	The maximum rate (0 to 4,294,967,295 bps).
MinRsvRate	The minimum guaranteed rate (0 to 4,294,967,295 bps).
Sched Type	The service class schedule type:  2–Best-Effort Schedule Type 3–Non-Real-Time Polling Service Schedule Type 4–Real-Time Polling Service Schedule Type 5–Unsolicited Grant Service with Activity Detection Schedule Type 6–Unsolicited Grant Service Schedule Type
Grant Size	The grant size (0 to 65535 bytes).
Grant Interval	The grant interval (0 to 4294967295 microseconds).
GPI	The grants per interval (0 to 127 grants).
Poll Interval	The poll interval (0 to 4294967295 microseconds).
Throughput	The overall throughput for this SID.
VRF Name	Name of the virtual interface that has been configured for Multiprotocol Label Switching (MPLS) Virtual Private Network (VPN) operation.
Good Codewords rx	Number of FEC codewords received without error.

**Table 5** *show interface cable sid Field Descriptions (continued)*

Field	Description
Corrected Codewords rx	Number of FEC codewords received with errors that could be corrected.
Uncorrectable Codewords rx	Number of FEC codewords received with non-correctable errors.

**Related Commands**

Command	Description
<a href="#">show interface cable signal-quality</a>	Displays information about the cable signal quality.

---

This document is to be used in conjunction with the documents listed in the [Additional References](#) section.

---

CCVP, the Cisco logo, and Welcome to the Human Network are trademarks of Cisco Systems, Inc.; Changing the Way We Work, Live, Play, and Learn is a service mark of Cisco Systems, Inc.; and Access Registrar, Aironet, Catalyst, CCDA, CCDP, CCIE, CCIP, CCNA, CCNP, CCSP, Cisco, the Cisco Certified Internetwork Expert logo, Cisco IOS, Cisco Press, Cisco Systems, Cisco Systems Capital, the Cisco Systems logo, Cisco Unity, Enterprise/Solver, EtherChannel, EtherFast, EtherSwitch, Fast Step, Follow Me Browsing, FormShare, GigaDrive, HomeLink, Internet Quotient, IOS, iPhone, IP/TV, iQ Expertise, the iQ logo, iQ Net Readiness Scorecard, iQuick Study, LightStream, Linksys, MeetingPlace, MGX, Networkers, Networking Academy, Network Registrar, PIX, ProConnect, ScriptShare, SMARTnet, StackWise, The Fastest Way to Increase Your Internet Quotient, and TransPath are registered trademarks of Cisco Systems, Inc. and/or its affiliates in the United States and certain other countries.

All other trademarks mentioned in this document or Website are the property of their respective owners. The use of the word partner does not imply a partnership relationship between Cisco and any other company. (0711R)

---

Copyright © 2002, Cisco Systems, Inc.  
All rights reserved.