



APPENDIX **A**

DOCSIS and CMTS Architectural Overview

This appendix provides a brief overview of general DOCSIS architecture and enhancements, all of which highlight the power and performance of the Cisco uBR10000 series CMTS.

- “DOCSIS Specification Summary” section on page A-1
- “CMTS Traffic Engineering” section on page A-5

For a more comprehensive explanation of DOCSIS concepts and features, refer to these documents on Cisco.com:

- *DOCSIS 1.1 for Cisco uBR7200 Series Universal Broadband Routers*
- *Cable FAQs*



Note

At the time of publication, the DOCSIS 1.1 specification is still being finalized. This document cites DOCSIS 1.0 and DOCSIS 1.1 specifications located at <http://www.cablelabs.com/cablemodem/specifications/>.

DOCSIS Specification Summary

Data is modulated and demodulated using the North American DOCSIS specifications, with downstream 6-MHz channels in the 54- to 860-MHz range and upstream ranges of 5 to 42 MHz. The cable interface supports NTSC channel operation, using standard (STD), Harmonic Related Carrier (HRC), or Incremental Related Carrier (IRC) frequency plans conforming to EIA-S542.

NTSC uses a 6 MHz-wide modulated signal with an interlaced format of 25 frames per second and 525 lines per frame. NTSC is compatible with the Consultive Committee for International Radio (CCIR) Standard M. PAL, used in West Germany, England, Holland, Australia, and several other countries.



Note

Cisco 6-MHz products can be used in Cisco 8-MHz cable plants. The products, however, operate at a maximum downstream bandwidth of 27 Mbps, ignoring 2 MHz of available channel width, and limiting upstream channel choices to the range below 42 MHz.

The DOCSIS radio frequency (RF) specification defines the RF communication paths between the CMTS and CMs (or CMs in STBs). The DOCSIS RF specification defines the physical, link, and network layer aspects of the communication interfaces. It includes specifications for power level, frequency, modulation, coding, multiplexing, and contention control. Cisco offers products that support all DOCSIS error-correction encoding and modulation types and formats, and products that support DOCSIS Annex B operations.

Overview of DOCSIS NTSC Cable Plants

DOCSIS-compliant cable plants that support North American channel plans use ITU J.83 Annex B RF. Figure 1-1 illustrates a DOCSIS two-way architecture.

Figure 1-1 DOCSIS Two-Way Architecture

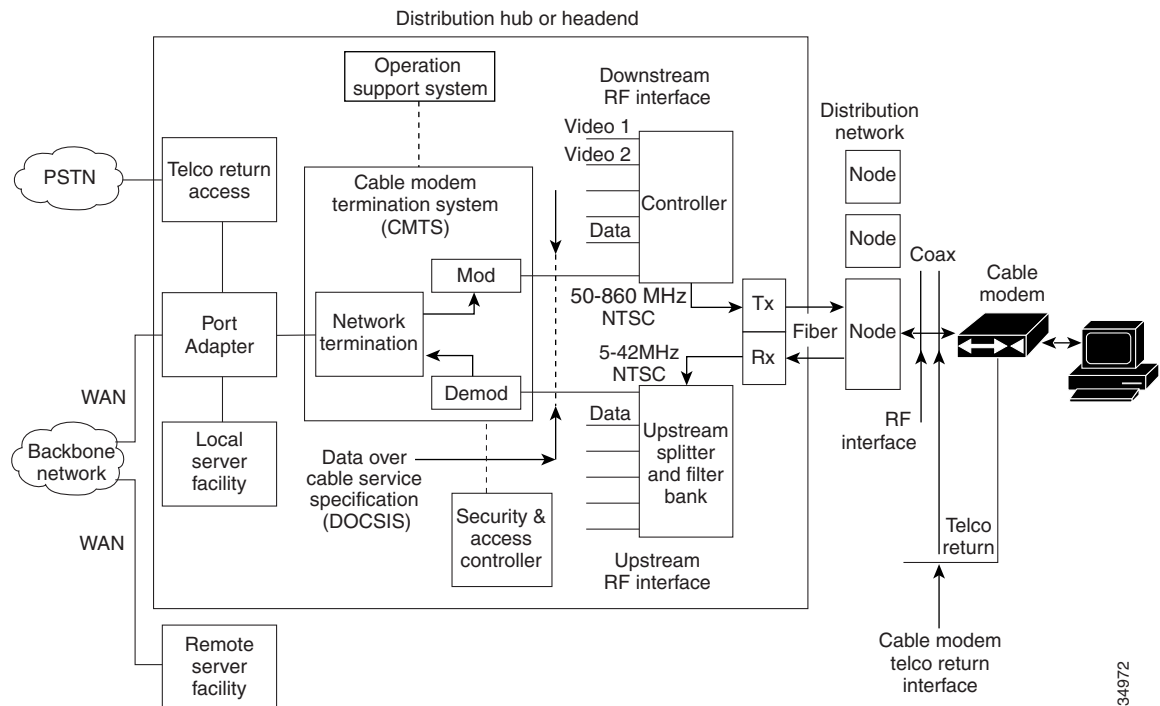

Larger cable companies typically have high-speed fiber backbones that carry Internet data, voice, and video between the following cable company facilities:

- Regional processing centers
- Headends
- Hubs

The fiber backbone can be made up of OC-3 (155 Mbps) to OC-48 (2488 Mbps) SONET or ATM rings. The backbone network can connect to other networks, including the Public Switched Telephone Network (PSTN), to other cable system backbones, or to public Internet interconnect points that multiple ISPs use.

The CMTS MAC domain typically includes one or more downstream paths and one or more upstream paths. Depending on the CMTS configuration, the CMTS MAC domain can be defined to have its downstreams on one cable interface line card with its upstreams on another card, or one or more CMTS MAC domains per cable interface line card.

Cisco provides high-speed routers to route interactive traffic between the backbone and Ethernet in the headend internal network. Signaling protocols maintain the network intelligence needed to route traffic optimally, automatically building and maintaining routing tables to direct traffic and signal failures for rerouting in the network.

QoS Policy Propagation on Border Gateway Protocol

BGP typically operates between the cable operator's regional network and external networks, providing routing information exchange between different networks. The Open Shortest Path First (OSPF) protocol is used in regional networks usually. For additional explanation of BGP in the context of DOCSIS NTSP cable plants, refer to [“Overview of DOCSIS NTSC Cable Plants” section on page A-2](#).

The Policy Propagation feature is a packet classification feature that provides a powerful, scalable means of utilizing BGP attributes to propagate destination-based packet classification policy throughout a large network via BGP routing updates.

IP precedence classes or QoS group IDs are associated with BGP community values, and in turn customers' prefixes are tagged with appropriate community values based on the class of service they have purchased from the network operator.

Normal BGP protocol operation then performs path selection, and the community value is mapped to the associated IP precedence class and installed in the express forwarding table along with the associated routing prefixes. Subsequent packets express forwarded to the selected destination prefixes are then tagged with the appropriate IP precedence value. Thus, packet classification policy can be propagated by scale via BGP without writing and deploying complex access lists at each of a large number of routers, which in turn ensures that return traffic to premium customers is handled as premium traffic by the network.

Overview of DOCSIS-Compliant Downstream Signals

Downstream signals are modulated using QAM-64 or QAM-256 quadrature amplitude modulation, based on the cable interface card used, your cable plant, and the significance of the data. DOCSIS defines the messages and data types for CMTS to CM (or CM in an STB) communications. All CMs listen to all frames transmitted on the downstream channel on which they are registered and accept those where the destinations match the units themselves or the devices that each CM supports.

The Cisco uBR10000 series CMTS supports multicast groups using standard protocols such as Protocol Independent Multicast (PIM), Distance Vector Multicast Routing Protocol (DVMRP), and Internet Group Management Protocol (IGMP) to determine if multicast streams are to be forwarded to a prescribed downstream CM or STB, or to a multicast routing peer.

The Cisco uBR10000 series software periodically sends MAC allocation and management messages—known as MAPs—to all CMs on the network, defining the transmission availability of channels for specific periods of time. The MAP rate is fixed—every 2 milliseconds.

Different transmission intervals are defined that associate an interval with a service identifier (SID). SIDs define the devices allowed to transmit, and provide device identification and class of service management. Software defines what type of transmission is allowed during the interval.

The CMTS system administrator typically assigns one or more SIDs to each CM, corresponding to the classes of service the CM requires. Each MAP is associated with a particular upstream channel. The SID concept supports multiple data flows and use of protocols that allow IP backbone QoS features to be extended to the CMTS. The CMTS schedules the times granted for sending and receiving packets, and if defined, manipulates the type of service (ToS) field in the IP packet header to accommodate QoS.



Note

Cisco IOS Release 12.2XF software supports extensions to DOCSIS 1.0 to operate with DOCSIS 1.0-based CMs or cable RF CPE devices (such as Cisco uBR924 cable access routers or Cisco uBR910 cable data service units) that also support DOCSIS 1.0 extensions.

DOCSIS 1.0 extensions build intelligence into the MAP file, which the CMTS sends to voice-enabled CMs to address jitter and delay. The extensions support unsolicited grants that are used to create a constant bit-rate-like stream between the CMTS and the CM. This is in contrast to typical data applications where CMs request grants from the CMTS before they can transmit upstream.

Overview of DOCSIS-Compliant Upstream Signals

The upstream channel is characterized by many CMs (or CMs in STBs) transmitting to the CMTS. These signals typically operate in a burst mode of transmission. Time in the upstream channel is slotted.

The CMTS provides time slots and controls the usage for each upstream interval. The CMTS sends regular mappings of minislot structure in downstream broadcast MAP messages. The CMTS allocates contention broadcast slots that all CMs can use, and allocates upstream minislots for unicast or noncontention data from specific CMs.

The CMTS allocates two basic types of contention slots on the upstream:

- Initial ranging slots that CMs use during their initialization phase to join the network. When the CMTS receives an initial ranging request from a CM using this kind of slot, the CMTS subsequently polls the CM, and other operational CMs, in unicast, noncontention station maintenance slots.
- Bandwidth-request minislots that CMs use to request data grants from the CMTS to send data upstream in noncontention mode. Any CM can use this type of minislot to request a data grant from the CMTS.

The stream of initial ranging slots and bandwidth request minislots comprise two separate contention subchannels on the upstream. Cisco IOS Release 12.2XF software uses a “dynamic bandwidth-request minislots-per-MAP” algorithm to dynamically control the rate of contention slots for initial ranging and bandwidth requests. The CMTS uses a common algorithm to vary backoff parameters that CMs use within each of the two upstream contention subchannels. The CMTS uses these algorithms to dynamically determine the initial ranging slots and bandwidth-request minislots to allocate on the slotted upstream.

When power is restored after a catastrophic power failure, a large number of CMs attempt to join the network simultaneously. This represents an impulse load on the initial ranging subchannel. The CMTS increases the frequency of initial ranging slots so that CMs can quickly join the network.

During high upstream data loads, the CMTS conserves the scarce upstream channel bandwidth resource and is more frugal in introducing upstream initial ranging slots. The CMTS schedules bandwidth-request minislots at low loads to provide low access delay. At high upstream loads, the CMTS reduces the number of contention-based request minislots in favor of data grants, while maintaining a minimum number of request slots.



Note

The system default is to have the automatic dynamic ranging interval algorithm enabled, automatic dynamic ranging backoff enabled, and data backoffs for each upstream on a cable interface. Commands to configure the dynamic contention algorithms include:

```
[no] cable insertion-interval [automatic [Imin [Imax]]] in msec
[no] cable upstream port number range backoff [automatic] | [start | end]
[no] cable upstream port number data-backoff [automatic] | [start | end]
```



Caution

In general, Cisco discourages adjusting default settings. Only personnel who have received the necessary training should attempt to adjust values.

The Cisco uBR10000 series equipment periodically broadcasts upstream channel descriptor interface line card or (UCD) messages to all CMs. These messages define upstream channel characteristics that include upstream frequencies, symbol rates and modulation schemes, forward error correction (FEC) parameters, and other physical layer values.

Upstream signals are demodulated using Quadrature Phase Shift Keying (QPSK) or quadrature amplitude modulation (QAM). QPSK carries information in the phase of the signal carrier, whereas QAM uses both phase and amplitude to carry information.

**Tip**

If your cable plant is susceptible to ingress or noise, Cisco recommends QPSK, based on the importance of the data. Frequencies below 20 MHz are more susceptible to noise and might require lower symbol rates. Higher frequencies might be able to support higher rates and use QAM modulation instead.

Overview of DOCSIS Two-Way Server Requirements

A TFTP server, DHCP server, and ToD server are required to support DOCSIS 1.0-based CMs on the network. A DOCSIS 1.0-based CM does not boot if these servers are not available.

Log server and security servers are not required to configure and operate a CM. If the log server or security servers are not present, a CM generates warning messages, but continues to boot and function properly.

ToD and TFTP servers are standard Internet implementations of the RFC 868 and RFC 1350 specifications. Most computers running a UNIX-based operating system, supply ToD and TFTP servers as a standard software feature. Typically, the ToD server is embedded in the UNIX *inetd* and requires no additional configuration. The TFTP server is usually disabled in the standard software, but can be enabled by modifying the *inetd.conf* file. Microsoft NT server software includes a TFTP server that can be enabled with the services control panel. Microsoft NT does not include a ToD server. A public domain version of the ToD server for Microsoft NT can be downloaded from several sites. For configuration information, refer to [Chapter 3, “Configuring Cable Interface Features for the Cisco uBR10012 Router.”](#)

CMTS Traffic Engineering

Sending data reliably upstream is a critical issue. Designing a robust upstream architecture requires balancing system parameters, establishing subscriber data requirements, and configuring the network to support those requirements.

Upstream spectrum varies greatly between cable plants. Maintaining stable return paths also differs based on varying patterns and levels of ingress noise and interference. Common problems in cable plants include:

- Electrical and magnetic interference (EMI)
- Thermal noise
- Carrier to noise (C/N) imbalances
- Interference of leaking signals
- Ingress due to other channels appearing at the desired channel frequency
- Distortion due to non-linearities of cable equipment
- Cross modulation—carrier to frequency distortion
- Hum and low frequency distortion
- Improper RF amplifier tuning
- Non-unity gains due to incorrect usage of attenuators
- Low-quality subscriber equipment
- Out of range signal power from the CMTS to the CM

When configuring your system, configure downstream and upstream parameters based on the fiber nodes involved, the required services the CM or STB supports, the importance of the data, and desired performance capabilities.

Your cable plant determines its data performance. Design your network to maximize its performance and capacity at minimum cost, while meeting subscriber data requirements. Select or customize upstream profiles for maximum trade-offs between bandwidth efficiency and upstream channel robustness once you are familiar with the system and have characterized your network. For example, QAM-16 requires approximately 7 dB higher C/N ratio to achieve the same bit error rate (BER) as QPSK, but it transfers information at twice the rate of QPSK.

**Note**

Older plants and plants with long amplifier cascades are more susceptible to ingress than newer plants. These plants produce more noise and signal level variances.

**Tips**

Cisco recommends you keep input to all amplifiers at the same power level in the upstream direction and keep output of all amplifiers in the downstream direction at the same power level. This is called unity gain. Tune amplifiers and other equipment properly at desired frequencies. To characterize and improve your cable plant's stability, follow procedures in the [Cisco uBR10000 Series Universal Broadband Router Hardware Installation Guide](#) on Cisco.com.

A DOCSIS cable plant has the following groups of traffic to size based on current service offerings:

- Basic Internet access data, which is asymmetrical; asymmetrical traffic supports a larger data rate in one direction—the downstream.
- VoIP traffic, which requires constant bandwidth, has low tolerance to latency and jitter, and is typically symmetrical—supporting the same data rate in downstream and upstream directions. VoIP generally requires phase-lock and jitter attenuation.
- VPN traffic, which requires secure transmissions; traffic is typically symmetrical since telecommuters exchange more data upstream than residential Internet access customers.
- Video, which can include digital video channels based on the services in your network.
- Signaling and maintenance—the DOCSIS MAC layer support includes DOCSIS encapsulation, initial maintenance, station maintenance, registration, frequency hop, and upstream channel changes.

You have a wide range of options to engineer your network. Define your network based on your cable facilities—headend or distribution hub—and your anticipated service offerings, subscription, and required service levels. Define data requirements relative to the number of subscribers to support and their usage patterns. Select upstream symbol rate, modulation format, and other parameters based on data requirements and return path characterizations.

If the service is asymmetrical, determine the ratio of downstream to upstream data rates. For basic Internet access where the majority of traffic is sent to a subscriber and the subscriber sends only a small amount of data upstream, use ratios ranging from 5:1 to 10:1.

Determine what data rate the service should support. Define the maximum and minimum data rate, answering the following questions. Do you want to define the minimum data rate relative to the maximum? Will the minimum data rate equal the maximum? Will it be a percentage of the maximum? Will the minimum data rate be zero?

**Note**

The minimum data rate has the greatest impact on the network. The network must be sized to accommodate this level of traffic to fulfill the defined service data requirements. The amount of bandwidth available to a group of subscribers establishes where, within the defined maximum and minimum data rates, a subscriber within a group is able to operate.

For video traffic planning purposes, use a typical bit rate to calculate densities of video streams within a channel. For QoS calculations, limit the number of video streams per channel to prevent packet drops. The key traffic parameter is how many IP video streams will fit into the RF channel.

Ideally, the network is sized so that it supports all subscribers being active at the same time at the maximum data rate. This results in an expensive network, however, where full capacity, particularly for residential subscribers, is rarely used. Cisco recommends designing your network to support a given level of over-subscription.

**Note**

Configure your network to support a percentage of all subscribers at a given data rate. At this level, the network supports the bandwidth needs of all active users. Provided the over-subscription rate is low enough, such that service definitions are met, all subscribers receive the service to which they subscribed.

**Caution**

With over-subscription, the network is unable to support all subscribers being active at the maximum data rate. If the over-subscription is severe enough, subscribers may be denied service.

Parameters to determine the over-subscription level include:

- Peak percentage of simultaneous users—Not all subscribers access the network at the same time. Subscribers have different access patterns that vary based on profiles; working hours; family demographics; type of user—telecommuter or residential Internet access customer. Only a portion of subscribers are active at a given time. This number serves as the “peak percentage of simultaneous users parameter”— busy hour number of subscribers.
- Average data rate per subscriber—Not only are all subscribers not active at the same time, but they do not continuously operate at peak rate. Using basic Internet access as an application, data that subscribers request and send downstream and upstream is subject to bursts. A group of subscribers, therefore, has an average data rate less than the maximum rate defined by the service.

**Note**

For some services, the average value might be the maximum rate. VoIP is such an application.

How bandwidth contention is handled depends on the mix of services defined and individual service definitions.

Percentage of homes passed subscribing to the service is another factor to consider. If this parameter is set too conservatively, the network is under-engineered and requires modification to grow the service. If set too aggressively, the network is over-engineered and costs for services are higher than they should be.

Full implementation of service levels requires additional higher layer items including scheduling, queuing priorities, bandwidth allocation. These items are addressed in DOCSIS 1.0 extensions. Refer to the [“Overview of Cisco uBR10012 Universal Broadband Router Software” section on page 1-1](#) and to additional chapters of this guide for additional information.

For detailed engineering calculations, refer to the Cisco Multimedia Traffic Engineering for HFC Networks publication (PDF format) on Cisco.com.

