



Introduction

This chapter provides an overview of the different components of IP/TV and describes how IP/TV Program Manager, in particular, works. This chapter contains the following sections:

- [About IP/TV, page 1-1](#)
- [IP/TV Components, page 1-2](#)
- [How IP/TV Components Interact, page 1-4](#)
- [IP/TV Features and Functionality, page 1-11](#)
- [New Features in IP/TV Release 5.1, page 1-12](#)
- [Channels in IP/TV and ACNS Networks, page 1-14](#)
- [About Scheduled and On-Demand Programs, page 1-15](#)
- [Accessing IP/TV Program Manager, page 1-18](#)

About IP/TV

IP/TV is a network-based application that delivers live or prerecorded, on-demand or scheduled programs to an unlimited number of users over any IP-based local- or wide-area network. Synchronized presentations and screen captures are also supported, in addition to a wide range of video management functions.

As part of the Cisco Content Networking family, IP/TV is a turnkey solution that brings movie-quality video over enterprise networks to the desktop of the user, eliminating the need for dedicated video cabling, monitors, or special viewing rooms. Designed with respect to scalability, high-quality broadcasts are delivered safely across large enterprises.

Applications for IP/TV include broadcast TV to the desktop, video on demand, computer-based training, distance learning, corporate communications, manufacturing process monitoring, and surveillance systems.

Cisco IP/TV Release 5.1 interoperates with a Cisco Application and Content Networking System (ACNS) network running Cisco ACNS software, Release 5.1. Interoperability with an ACNS network provides a single, integrated caching and content delivery platform for the streaming operations of IP/TV.

IP/TV Release 5.1 supports a wide variety of audio and video formats, including MP3, Advanced Audio Codec-Low Complexity (AAC-LC), H.261, Moving Picture Experts Group-1 (MPEG-1), MPEG-2, and MPEG-4 (Simple Profile).

To view a 7-minute video that describes IP/TV capabilities, click **Introduction Video** on the Cisco IP/TV Installer CD.

IP/TV Components

IP/TV consists of three separate components: IP/TV Viewer, IP/TV Program Manager, and IP/TV Server.

IP/TV Viewer is the client component and is available as software only, whereas IP/TV Program Manager comes only as a hardware appliance. IP/TV Server is available either as a software-only option or as a hardware appliance. As a software-only option, these components must be run on third-party PC systems that meet the minimum requirements of the specific IP/TV component.

As a hardware appliance, IP/TV Server comes installed on the Broadcast Server models of the Cisco IP/TV 3400 Series Server hardware.

Refer to the *Cisco IP/TV 3400 Series Servers User Guide* for more information on server hardware configuration and setup.

IP/TV Viewer

IP/TV Viewer resides on the client and lets you view programs. A program is an audio, video, or text transmission over the network. IP/TV Viewer has a customizable user interface that displays a list of scheduled and on-demand programs. IP/TV Viewer allows you to subscribe to any of the listed scheduled programs, and plays the program at the scheduled time. You can also browse among all currently running programs.

IP/TV Viewer obtains program information from IP/TV Program Manager, and displays programs served by IP/TV Server or other servers. It can also display programs multicast from the Multicast Backbone (MBone) of the Internet or from other servers that transmit in MBone-compatible format.

IP/TV Viewer can run as a standalone application, a helper application activated by a web browser, or a browser plug-in. It is available as software only and runs on Windows 98, Windows 2000, Windows NT 4.0, and Windows XP.

Refer to the *Cisco IP/TV Viewer User Guide* for more information on how to install and use IP/TV Viewer.

IP/TV Program Manager

IP/TV Program Manager is accessed from a browser and is used by the system administrator or broadcast administrator to set up and manage IP/TV scheduled or on-demand programs, channels, recordings, and file transfers among IP/TV Servers.

IP/TV Program Manager Release 5.1 is a Linux-based application that runs on the Cisco Content Engine models CE- 565 and CE-7305. You can access IP/TV Program Manager from Netscape Versions 4.5x through 4.7x, or Microsoft Internet Explorer Version 5.5 or later. The browser must have Java and JavaScript enabled.

This guide provides information on how to install, configure, administer, and use IP/TV Program Manager.

IP/TV Server

IP/TV Server, which is controlled by IP/TV Program Manager, serves and records programs. It multicasts and records scheduled programs, unicasts on-demand programs, and transfers files according to the schedules defined in IP/TV Program Manager.

IP/TV Server is available as software only or comes installed on Cisco IP/TV 3400 Series Server hardware appliances (IP/TV Broadcast Server).

When configured with a video capture card, IP/TV Server can do live encoding and can serve programs. IP/TV Server also supports SmallCast for unicast transmission across nonmulticast-enabled routers (or across the Internet) and then multicasting to viewers on the remote network segment.

IP/TV Server runs on Windows 2000 Server and Windows NT 4.0.

Refer to the *Cisco IP/TV Broadcast Server User Guide* for information on how to install, configure, and administer IP/TV Server.

How IP/TV Components Interact

Cisco IP/TV Release 5.1 can function as a standalone IP/TV application (see the following section, “[IP/TV as a Standalone Application](#)”) or as part of an ACNS network (see the “[IP/TV as Part of an ACNS Network](#)” section on page 1-6). As a standalone application, IP/TV components interact only with one another. In an ACNS network, IP/TV components operate with ACNS network components as well.

IP/TV as a Standalone Application

You can use IP/TV for the broadcast of scheduled live or prerecorded programs, on-demand programs, or a combination of the two. You can use a given IP/TV Server to broadcast both scheduled and on-demand programs.

[Figure 1-1](#) shows the interactions between IP/TV components in the case of scheduled programs. Note that although IP/TV Viewer receives program descriptions only from IP/TV Program Manager, the programs are sent to

IP/TV Viewer from the various media servers. The media servers may be IP/TV Servers, MBone servers, or other servers that run IP/TV-compatible MBone tools.

Figure 1-1 IP/TV Components—Scheduled Programs

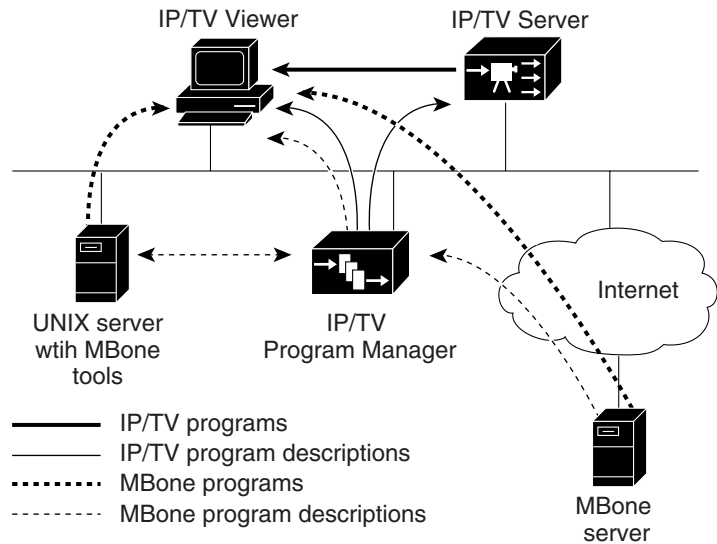
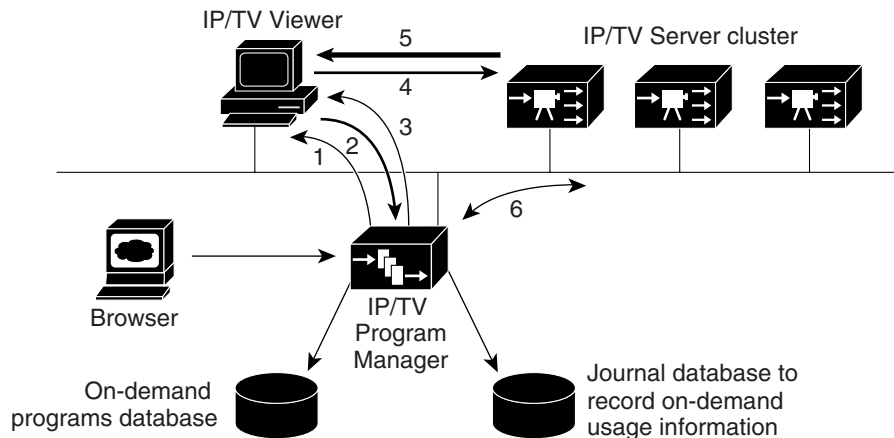

Figure 1-2 shows the interactions between these components in the case of on-demand programs. IP/TV Program Manager manages a group (cluster) of servers that together form a virtual machine, with an integrated database to keep track of program information. Clustering allows IP/TV Program Manager to balance the server load by routing a user program request to the least-busy server.

Figure 1-2 IP/TV Components—On-Demand Programs



1. IP/TV Viewer receives on-demand program descriptions
2. IP/TV Viewer makes on-demand request
3. Program Manager redirects IP/TV Viewer to least busy server
4. IP/TV Viewer makes on-demand program request of server
5. Server serves on-demand program to IP/TV Viewer
6. Server control and status

102197

IP/TV as Part of an ACNS Network

When IP/TV is integrated with an ACNS network, IP/TV Program Manager is defined as an ACNS component and facilitates interaction among IP/TV components (IP/TV Program Manager, IP/TV Server, and IP/TV Viewer) and ACNS components (Content Engines, Content Routers, and Content Distribution Manager).

IP/TV makes use of the channel concept in ACNS software to distribute programs over the ACNS network. You must assign IP/TV programs to ACNS network channels to distribute them over the ACNS network. For more information on channels, refer to the *Cisco IP/TV Broadcast Server User Guide*.

**Note**

ACNS software considers all scheduled programs as live programs. To distribute scheduled programs on the ACNS network, you must assign them to a live channel on the ACNS network.

When you create an IP/TV scheduled program to distribute over the ACNS network, IP/TV Program Manager creates an XML file called a program file that contains information about the scheduled program. IP/TV Program Manager sends this file to the Content Distribution Manager in the ACNS network.

**Note**

The program file is not visible to the user.

IP/TV Program Manager communicates with IP/TV Broadcast Server and schedules a unicast of the program to the root Content Engine in the ACNS network. On receiving the program file from IP/TV Program Manager, the Content Distribution Manager sends information about the scheduled program to all the Content Engines subscribed to the live channel associated with the program. When the scheduled program begins, the root Content Engine receives the unicast stream from IP/TV Broadcast Server and sends it to other Content Engines subscribed to that live channel. The Content Engines that are configured as multicast-to-unicast converters unicast the program to remote Content Engines, which in turn multicast the program to their local users.

[Figure 1-3](#) shows the various steps in creating and distributing a scheduled IP/TV program over an ACNS network.

Figure 1-3 IP/TV-ACNS Network Interaction—Scheduled Program

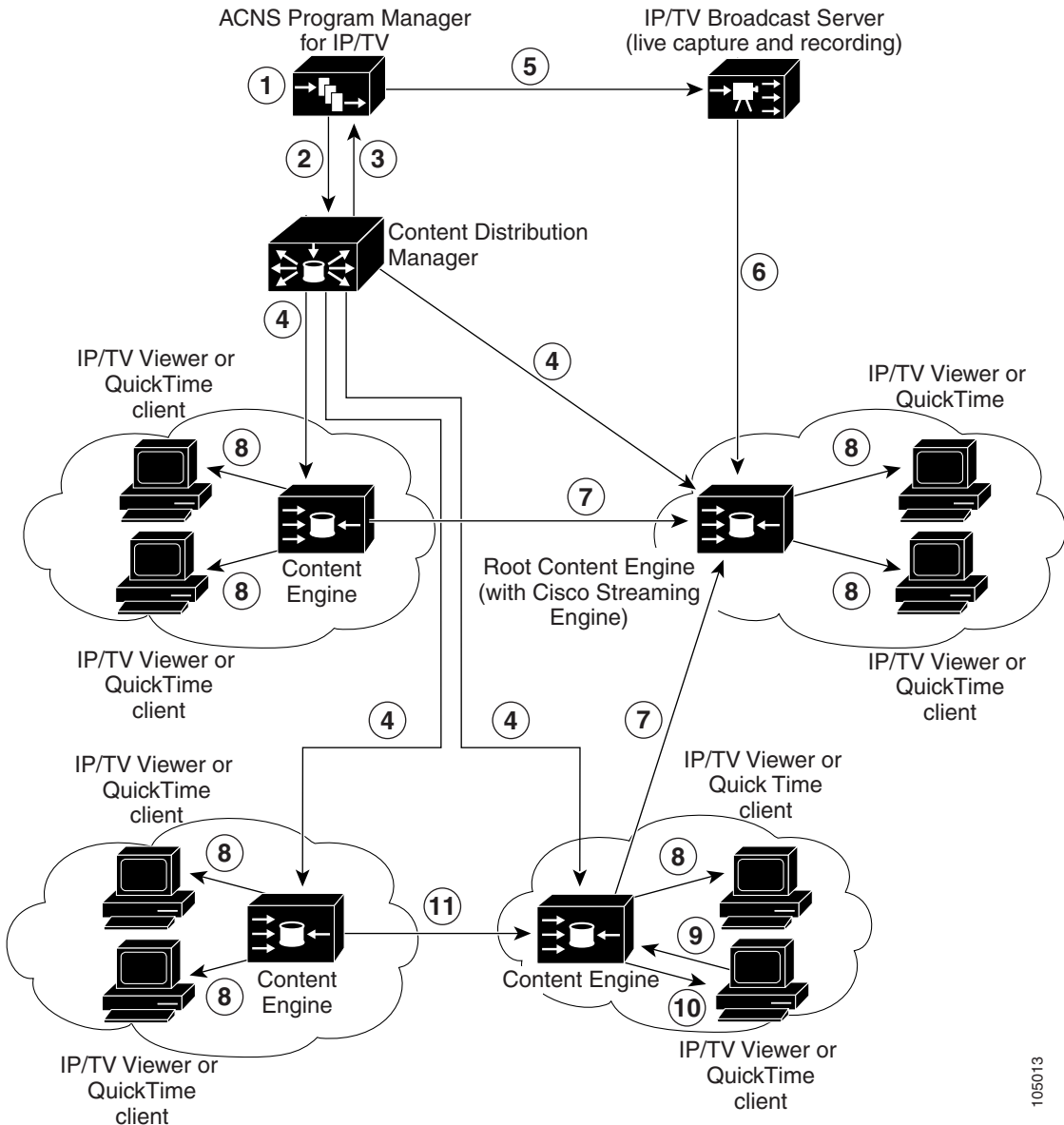

105013

1. The administrator creates a scheduled program on IP/TV Program Manager and assigns it to a live channel on the ACNS network.
2. IP/TV Program Manager sends the program information to the Content Distribution Manager in the ACNS network.
3. IP/TV Program Manager obtains the address of the root Content Engine from the Content Distribution Manager.
4. The Content Distribution Manager passes the program information to all Content Engines subscribed to that live channel.
5. IP/TV Program Manager sends the program information and the address of the root Content Engine to IP/TV Broadcast Server.
6. When the program begins, IP/TV Broadcast Server sends a unicast stream to the root Content Engine.
7. Edge Content Engines subscribed to the live channel fetch the program as a unicast stream from the root Content Engine.
8. Edge Content Engines multicast the program within their multicast cloud.
9. Users who are unable to join the multicast send requests for unicast streams.
10. Edge Content Engines serve the requests as unicast streams.
11. Edge Content Engines also serve unicast requests from child Content Engines.

For on-demand programs, the process is slightly different from that for a scheduled broadcast. When you create an on-demand program, IP/TV Program Manager creates an XML file called the manifest file that contains information about the program. The manifest file is saved at the manifest file location specified in the channel information sent by the Content Distribution Manager.

**Note**

Program information in the manifest file includes the type of content, file format, source server, and the time of acquisition. You can access the manifest file from the manifest file URL specified in the Content Distribution Manager and edit the contents. For more information on manifest files, refer to the *Cisco ACNS Software Deployment and Configuration Guide, Release 5.1*.

Based on the information in the manifest file, the root Content Engine fetches the content from IP/TV Broadcast Server using FTP and then distributes the content to all Content Engines that are subscribed to the channel (so-called pre-positioning of content). When users access the program, the content routing

mechanism redirects the request to the closest Content Engine that has the required program. If the Content Engine is unable to serve the program, the content routing mechanism redirects the request to the origin server.

Figure 1-4 portrays the steps involved in creating and distributing an IP/TV on-demand program over an ACNS network.

Figure 1-4 IP/TV-ACNS Network Interaction—On-Demand Program

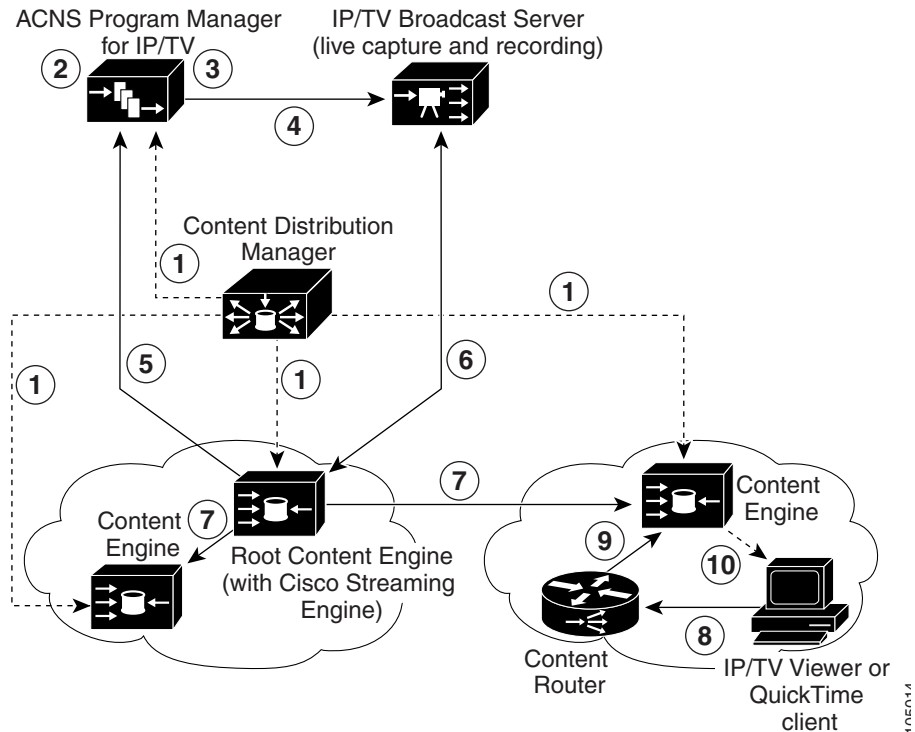

1. The Content Distribution Manager sends channel information to IP/TV Program Manager and all the Content Engines subscribed to that channel.
2. The administrator creates a program on IP/TV Program Manager and assigns it to the ACNS network channel.
3. IP/TV Program Manager creates the manifest file for the program and stores it at the manifest file location specified in the channel information sent by the Content Distribution Manager.

4. IP/TV Program Manager sets up the program on IP/TV Broadcast Server.
5. Based on the channel information, the root Content Engine fetches the manifest file from IP/TV Program Manager.
6. Based on the information in the manifest file, the root Content Engine acquires the on-demand program from IP/TV Broadcast Server using FTP.
7. The root Content Engine distributes the program to all other Content Engines subscribed to the channel (so-called pre-positioning of content).
8. The user requests an on-demand program.
9. The Content Router in the network directs the request to the nearest Content Engine that possesses the on-demand program.
10. The Content Engine sends the program to the user as a unicast stream.

IP/TV Features and Functionality

IP/TV has the following turnkey, scalable features for delivering high-quality video over enterprise networks:

- **Codecs**—Supports MPEG-2 for DVD quality, MPEG-1 for TV/VCR quality, and ISO MPEG-4 for high quality at lower bandwidths.

Industry standards for media streaming comply with ISMA specifications to ensure interoperability.

- **Integration with an ACNS network**—Provides a single, integrated caching and content delivery platform for the streaming operations of IP/TV.
- **IP multicast (with source-specific multicast [SSM])**—Facilitates delivery over multicast networks to minimize bandwidth for live and scheduled video. A single stream is broadcast over the network regardless of the audience size.
- **Quality of Service**—Enables QoS using Resource Reservation Protocol (RSVP) to ensure that bandwidth is allocated for video delivery.

Audio and video streams are delivered independently to minimize the impact of network congestion on the client. Audio has priority.

- **IP/TV StreamWatch**—Allows quality and usage monitoring of clients during video delivery and generates logs for postevent analysis. IP/TV StreamWatch is scalable to large deployments.

- Question Manager—Allows clients to send text queries to a moderator during a broadcast delivery. The web-based Question Manager of IP/TV allows the users of browser plug-ins to make use of this feedback channel.
- SmallCast—Allows content delivery across one or more nonmulticast-enabled routers (or across the Internet) as a unicast transmission, and then is multicast to clients on the remote network segment.
- Media synchronization tools—Provides Web Presenter, ScreenCaster, and SlideCast integrated synchronization tools for the ability to deliver presentations (in the form of HTML windows, screen captures, or .jpg files) with video content.
- Scheduling—Allows setup of live or scheduled video delivery through a browser interface.
- Program listing—Automatically generates and updates the program listing at the client. The program listing is accessible from either a web browser or an IP/TV client.

New Features in IP/TV Release 5.1

IP/TV Release 5.1 introduces the following new features:

- [IP/TV-ACNS Network Interoperability](#)
- [IP/TV Viewer-Cisco Streaming Engine Interoperability](#)
- [Support for the MOV Format](#)
- [Media File Exporter Utility](#)

IP/TV-ACNS Network Interoperability

Cisco IP/TV Release 5.1 interoperates with an ACNS network running Cisco ACNS software, Release 5.1. IP/TV Program Manager Release 5.1 runs on the Cisco Content Engine hardware and facilitates interaction with ACNS software. Integration with an ACNS network allows IP/TV users to capitalize on the caching and content delivery features of ACNS software for effective bandwidth usage. The administrator can broadcast live content over an ACNS network and add prerecorded IP/TV content into the ACNS network. In the case of live streams, ACNS relays the streams over the network, whereas for on-demand

programs, the content is distributed to various Content Engines in the network that act as storage servers. When a user requests an on-demand program, the content routing mechanism of the ACNS network directs the request to the closest Content Engine that stores the file. This helps reduce network traffic and ensures high-speed response to the user's request.

**Note**

Both IP/TV Release 5.1 and ACNS software, Release 5.1 can function as standalone applications. Users can set up IP/TV and ACNS to work as standalone applications or as an integrated application.

For information on configuring IP/TV as part of an ACNS network, see the [“Setting IP/TV Program Manager Defaults and Preferences” section on page 3-2](#).

IP/TV Viewer-Cisco Streaming Engine Interoperability

Cisco IP/TV Viewer Release 5.1 supports interoperability with the Cisco Streaming Engine. IP/TV Viewer can request and render on-demand and live programs from the Cisco Streaming Engine. However, interoperability is limited to requesting and rendering content.

Support for the MOV Format

Cisco IP/TV Release 5.1 supports recording and streaming of files in QuickTime Movie (MOV) format over an ACNS network. MOV is a container format that is compatible for streaming content over ACNS networks.

**Note**

Cisco IP/TV Release 5.1 supports streaming of other formats, such as MPG, MP4, and RTP. However, these formats are not supported by the Cisco Streaming Engine that performs streaming operations in ACNS software.

Interoperability with the Cisco Streaming Engine enables IP/TV Viewer to play MOV (.mov) files streamed over the network.

Cisco IP/TV Release 5.1 supports the following audio and video codecs for MOV recording:

Audio: MPEG, mu-law, Audio Video Interleaved (AVI), Global System for Mobile Communication (GSM), Digital Video Interactive (DVI), Advanced Audio Coding (AAC), 8-bit linear, and 16-bit linear

Video: H.261, MPEG-1, MPEG-2, and MPEG-4

**Note**

IP/TV does not support MOV recording of Web Presenter programs, MP2T streams, and Indeo video. IP/TV supports MOV recording of MP3 audio; however, the recording cannot be played using the QuickTime Player.

Media File Exporter Utility

IP/TV Release 5.1 introduces the Media File Exporter utility to convert the format of existing media files to the .mov format. This feature is accessed from the IP/TV Server window and makes files compatible for streaming over the ACNS network.

Channels in IP/TV and ACNS Networks

Both IP/TV and ACNS networks use channels to manage programs. However, the concept of a channel in IP/TV differs from that used in an ACNS network.

In IP/TV, a channel constitutes a template for programs. The programs on a particular channel share the channel address and a variety of common characteristics such as passwords and preferred audio and video settings. For more information on the channel concept in IP/TV, see the [“Programs and Channels” section on page 1-16](#).

In ACNS networks, a channel is the mapping of a set of content objects from a single website to a set of devices or device groups. Content objects associated with a specific channel have a common domain (host) name; in other words, the content in a specified channel resides in a single location on the origin web server.

Refer to the *Cisco ACNS Software Deployment and Configuration Guide* for more information on the concept of channels in ACNS networks.

When IP/TV is integrated with an ACNS network, channels are used to configure IP/TV Program Manager as part of the network. A channel is created in ACNS software using the Content Distribution Manager GUI, with IP/TV Program Manager as the origin server for that channel. This channel name is specified in all the programs created from that IP/TV Program Manager. If you do not specify the channel name, the programs are not distributed in the ACNS network.

About Scheduled and On-Demand Programs

IP/TV Program Manager can manage both scheduled and on-demand programs. A scheduled program consists of either live or prerecorded content that is multicast over the network at a set time. An on-demand program consists of prerecorded content that is unicast to a single client whenever it is requested.

The uses, advantages, and limitations of scheduled and on-demand programs are discussed in the sections that follow.

Scheduled Programs

Scheduled programs are either live or prerecorded programs that are available to viewers at times defined by IP/TV Program Manager, and are delivered by one multicast data stream per media type (video, audio, Web Presenter, or SlideCast). Using multicast technology, scheduled programs can reach unlimited numbers of viewers simultaneously without overloading the network (refer to Chapter 1 of the *Cisco IP/TV Broadcast Server User Guide*).

Scheduled programs can be live content sent to viewers in real time, or prerecorded content that can be played repeatedly at scheduled times. Typical uses of scheduled programs include employee communications, group training, and distance learning.

How Scheduled Programs Work

In IP/TV Program Manager, you define a list of scheduled programs and assign them to one or more specified IP/TV Servers. The list of programs is automatically sent to IP/TV Viewer, and the programs can be watched by users at the scheduled time.

Programs and Channels

When you define scheduled programs, it is important to understand the relationship between programs and channels. In the IP/TV context, channels and programs are nearly identical to their network television equivalents, but there are a few differences. Understanding these differences will help you create the best model for your organization and manage IP/TV scheduled programming most effectively.

On network television, a channel carries either a single, continuous program (such as a 24-hour news channel) or a series of noncontinuous, back-to-back programs. Programs cannot exist without channels. All programs must be carried by a channel in order to be viewable. To view a program, the user tunes to its channel. The channel itself constitutes the address of all programs on that channel.

In IP/TV, a channel can carry either a single, continuous program, a series of noncontinuous, back-to-back programs, or both.

A noncontinuous program can overlap a continuous program. It is defined as a separate entity that can be tuned in by the user.

An example of a continuous program that has a noncontinuous program overlapping it is a 24-hour news service. The news program is always on, and users can tune in whenever they want to get a news update. Suppose, though, that the financial news is always discussed for one-half hour starting at 3:00 p.m., and some users want to subscribe only to the financial news so that IP/TV automatically launches the program for them. You can define a noncontinuous program that begins at 3:00 p.m. and runs for 30 minutes. The noncontinuous program is a subset of the 24-hour news program, and overlaps it for that 30-minute interval. This is a mechanism to allow the user to subscribe to a small portion of the continuous program.

A channel constitutes a template for programs. The programs on that channel share the channel address and a variety of common characteristics such as passwords.

Unlike network television, an IP/TV program need not be assigned to a channel. It can exist independently. In this case, the program simply has its own address. Thus, if you prefer, you can omit the channel mechanism altogether. However, a channel is useful if you want to create programs with similar characteristics.

**Note**

Channels are invisible to users of IP/TV Viewer. To view a program, the user can either subscribe to the program explicitly, or select the program spontaneously. The resulting address belongs either to a channel or to an independent program. Either way, the actual address is invisible to the user.

On-Demand Programs

On-demand programs are available to individual users to watch at the time of their choosing. Because on-demand programs use unicast technology, multiple requests for an on-demand program require more network bandwidth than for a scheduled program (refer to the “Unicast Traffic” section in Chapter 1 of the *Cisco IP/TV Broadcast Server User Guide*). We recommend that you use the on-demand mode for programs that are accessed less frequently, such as individualized corporate training and video archives, and use scheduled mode for group viewing.

IP/TV Program Manager manages a cluster of servers that together form one larger server, with an integrated database to keep track of server and program information. IP/TV Program Manager automatically collects a list of available media files from the cluster and, using the Cisco FTP server, can also schedule distribution of files from one server to another or from an outside source to one or more of the servers.

The administrator then defines these files as programs in IP/TV Program Manager, using a hierarchical tree of program categories. A top-level category can contain subcategories, which you navigate to by clicking links. This hierarchical structure allows you to manage and make available a large library of programs. Unlike on-demand programs, scheduled programs do not have a tree structure, but their program listing on the client can be easily sorted by name, start time, end time, media type, or program description.

IP/TV Viewers receive on-demand programs only from their local cluster. One or more subnets can be defined as a proximity group, and one or more proximity groups are associated with a given server cluster. This allows the administrator to localize network traffic by ensuring that IP/TV Viewers receive on-demand programs only from their local cluster.

IP/TV Program Manager distributes a list of available on-demand programs to IP/TV Viewers, and this list is displayed on the program listing screen. When a user requests a program, IP/TV Program Manager uses information from the database to assign the least-busy server in the cluster to meet the request, and then directs IP/TV Viewer to that server. If one of the servers fails, or needs to be taken out of service, IP/TV Program Manager balances the request load among the remaining servers.

When IP/TV runs in an ACNS network, the root Content Engine acquires the on-demand content from IP/TV Broadcast Server (through IP/TV Program Manager) and pre-positions it on other Content Engines in the ACNS network. When a user requests an on-demand program, the Content Router in the ACNS network directs the request to the Content Engine that is nearest to the user and is capable of serving the content. If the Content Engine is unable to serve the file, it redirects the request to the origin server. Pre-positioning the content on Content Engines reduces network traffic and provides fast access to content for users.

Accessing IP/TV Program Manager

IP/TV Program Manager is accessed remotely using a browser. The computer used to access IP/TV Program Manager must run Netscape Navigator 4.5x through 4.7x, or Microsoft Internet Explorer 5.5 or later. The browser must have Java and JavaScript enabled. Check the browser Options or Preferences menu to be sure that these features are enabled.

To access IP/TV Program Manager, go to the following URL:

`http://Programmanagerhost/`

where *Programmanagerhost* is the DNS name or IP address of IP/TV Program Manager.

Enter the administrative username and password for the IP/TV Restricted Zone and then click **OK**.



Note

The default username for the administrative account is set to admin; the default password is set to default. For information on setting up user accounts and passwords, see the “[Setting Up User Accounts for IP/TV Program Manager](#)” section on page 3-1.

When you access IP/TV Program Manager for the first time, store the URL in the frequently visited sites list of your web browser. The actual mechanism you use varies depending on which browser you use. Refer to your browser documentation or help system for more information.

When you access IP/TV Program Manager, the first window that appears is the IP/TV Program Manager main window. (See [Figure 1-5](#).)

Figure 1-5 IP/TV Program Manager Main Window

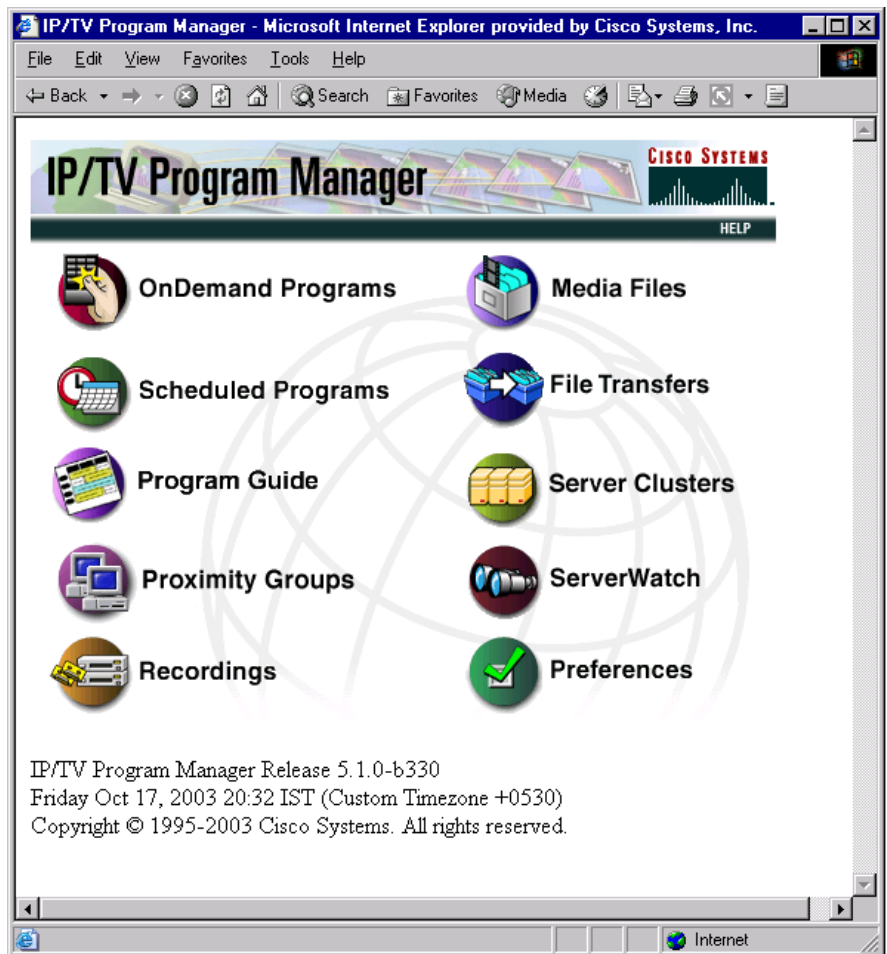

102034

The IP/TV Program Manager main window contains multiple links for setup and configuration, including on-demand and scheduled programs creation, proximity group and server cluster configuration, recordings and file transfer setup, and server status monitoring.

- The **OnDemand Programs** link takes you to the OnDemand Programs window, which displays information about existing on-demand programs and allows you to define new on-demand categories or programs. You can also search for an on-demand category or program by program name, category, keywords, or description. See Chapter 5, “[Managing On-Demand Programs](#),” for more information.
- The **Scheduled Programs** link takes you to the Scheduled Programs window, which displays information about existing scheduled programs and allows you to define new scheduled programs. See Chapter 6, “[Managing Scheduled Programs](#),” for more information.
- The **Program Guide** link takes you to the IP/TV Program Guide (also known as Web-Based Program Guide, or WBPB) window, which allows you to search for programs matching specific criteria. See Chapter 9, “[Using the Web-Based Program Guide](#),” for more information.
- The **Proximity Groups** link takes you to the Proximity Groups window, which displays information about existing proximity groups, and allows you to define new proximity groups and subnets. A proximity group is a collection of subnets in which client viewers reside. For more information, see the “[Managing Proximity Groups and Subnets](#)” section on page 3-35.
- The **Recordings** link takes you to the Recordings window, which displays information about existing recordings, and allows you to define new recordings. For more information, see the “[Recording Scheduled Programs](#)” section on page 6-31.
- The **Media Files** link takes you to the Media Files window, in which you can view media files and edit their metadata. A link is provided to allow you to create new on-demand programs. For more information, see the “[Using Media Files](#)” section on page 5-2.
- The **File Transfers** link takes you to the File Transfers window, which displays information about existing scheduled file transfers among IP/TV Servers, and allows you to define new file transfers, display the results of a file transfer, and view or clear the file transfer log. Refer to the *Cisco IP/TV Broadcast Server User Guide* for more information.

- The **Server Clusters** link takes you to the Server Clusters window, which displays a list of server clusters and allows you to define a new cluster or server. For more information, see the [“Defining Servers and Server Clusters” section on page 3-23](#).
- The **ServerWatch** link takes you to the ServerWatch window, where you can monitor the current status of servers. For more information, see the [“Monitoring Server Status” section on page 4-6](#).
- The **Preferences** link takes you to the Preferences window, where you can set IP/TV Program Manager options. In general, preferences should be changed only by the system administrator or network manager who installed IP/TV Program Manager. See Chapter 3, [“Setting Up IP/TV Program Manager,”](#) for more information.
- The **Help** link launches the IP/TV Program Manager online help utility. See the [“Using Online Help”](#) section in the preface of this guide for a description of online help.

