

Cisco 11500 Series Content Services Switch Switch Control Module Reference

The CSS 11500 series Switch Control Module (SCM) provides master control and is responsible for the following functions: system powerup and boot control, centralized routing table management, system-wide connection management, and interface to an external Network Management Station.

[Figure 1](#) shows an SCM (CSS5-SCM-2GE=).

Figure 1 SCM LEDs and Connectors

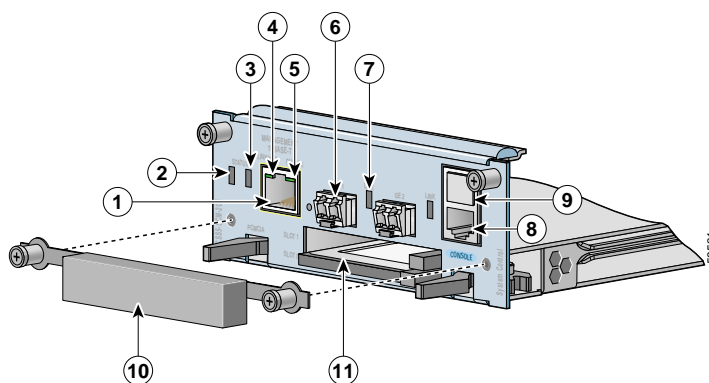

1	10-Mbps half-duplex Ethernet management connector	7	Link and activity LED for the associated GBIC connector on the left
2	Bicolor status LED (green and red)	8	RJ-45 RS-232 Console connector
3	Amber status LED	9	RJ-45 RS-232 Diag connector for field service diagnostic use only (A connector cover is provided. Removing the cover voids the warranty.)
4	Link/Act LED		
5	Duplex LED	10	PCMCIA slot cover
6	LC-type SFP GBICs (one of two)	11	PCMCIA slot 0 on the bottom containing a flash or hard disk and slot 1 on top (shown empty)

Only one SCM is required in a configuration, however you can install and configure a second SCM for redundancy in a CSS 11506. A secondary SCM is passive, and does not load share processing functions with the primary module. If the primary SCM fails, the CSS reboots and connections are terminated. Then the secondary SCM becomes primary automatically.



Corporate Headquarters:
Cisco Systems, Inc., 170 West Tasman Drive, San Jose, CA 95134-1706 USA

Copyright © 2003. Cisco Systems, Inc. All rights reserved.



Note

Before you remove or install a module, make sure you properly ground yourself prior to handling the module. For example, wear an antistatic wrist strap (included in the kit with the module) and stick the copper-tape end of the strap to an unpainted metal surface on the chassis. Make sure that the wrist strap makes good contact with your skin.

Removing the SCM



Caution

You must power down the CSS to remove an SCM. If you remove a powered-on SCM from an operational CSS, the CSS terminates all communications and reboots.

To remove an SCM:

1. Locate the failed SCM (its Status LEDs will be off). See [Figure 1](#).
2. If necessary, power down the CSS.
3. Remove all cables from the module.
4. With a Phillips screwdriver, remove the PCMCIA cover and then loosen the spring-loaded screws on the front of the module faceplate. See [Figure 2](#).

Figure 2 Removing the PCMCIA Cover from the SCM

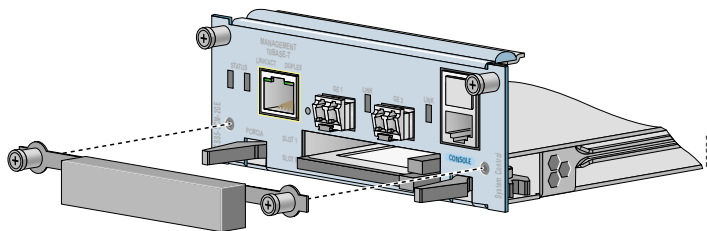

5. Extend both ejectors simultaneously to unseat the module connector from the backplane and slide the module out of the slot.

6. Remove the SFP GBICs from the SCM. Press the ejectors on the SFP GBICs. Slide them out of the module and set them aside. See [Figure 3](#).

Figure 3 *Ejecting the SFP GBIC from the SCM*

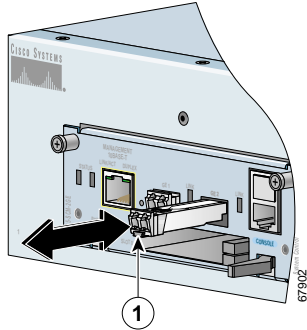

1	SFP GBIC ejector
---	------------------

7. Remove the flash or hard disks from the SCM. Press the ejectors to the right of the disks. Slide them out of the module and set them aside. See [Figure 4](#).

Figure 4 *Ejecting the Disk from the SCM*

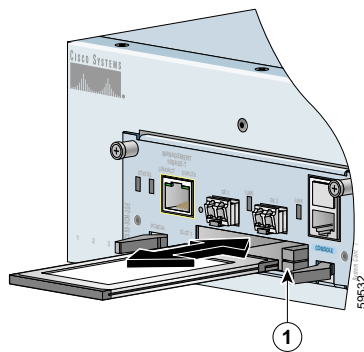

1	Disk ejector
---	--------------



Note

The replacement SCM contains a 144 MB Small Outline RamBus Inline Memory Module (SO-RIMM). If your failed module has a 288 MB SO-RIMM, you must remove its SO-RIMM, and place it in the replacement SCM. See [“Removing and Replacing the Memory Module”](#) later in this document.

Installing the SCM

To install an SCM (refer to the previous illustrations):

1. Properly ground yourself prior to handling the module, as noted on the previous page.
2. If applicable, reinstall the memory module, SFP GBICs, and flash or hard disks in the SCM.
3. Locate the slot in the chassis for the SCM. SCMs are restricted to slots 1 and 2.

4. Insert the module into the board guides at the left and right sides of the slot, and then slide the module into the chassis by pressing firmly at the left and right of the faceplate.
5. Close both ejectors simultaneously to seat the module connector into the backplane.
6. Using a Phillips screwdriver, tighten the spring-loaded screws on the front of the module faceplate.
7. With a Phillips screwdriver, replace the PCMCIA cover (see [Figure 2](#)) and then tighten the spring-loaded screws on the front of the module faceplate.
8. Replace the cables. Note that the SFP GBICs have LC-type connectors and require LC-type fiber cables.
9. Reboot the CSS.
10. If you installed a secondary SCM, use the **passive sync** command to copy the boot config from the primary SCM to the secondary SCM.

If you installed a replacement for a primary SCM, the replacement has default settings for the administrative username and password, IP address, subnet mask, and primary boot record. To reconfigure these parameters, access the Offline Diagnostic Monitor menu at the boot prompt. For information on using the Offline Diagnostic Monitor menu, refer to the *Content Services Switch Administration Guide*.

Table 1 describes the SCM LEDs and their indications.

Table 1 Switch Control Module LED Descriptions

LED Name	Color	State	Indicates
Status (left)	Green	Solid	The module is ready.
		Variable blink	Disk activity is occurring.
		Slow blink	Another CSS module has failed.
	Red	Solid	The module failed the power-up self test during the boot process.
		Slow blink	The module failed.
	No color	Off	The module failed and has no power.
Status (right)	Amber	Slow blink	The module is offline and active.
		Solid	The module is online and not active (secondary).
Link/Act for the Ethernet Management Port	Green	Off	There is no link.
		On	The link is established but there is no activity.
		Blinking	The link is established with transmit or receive activity.
Link for each Gigabit Ethernet Port	Green	Off	There is no link.
		On	The link exists and synchronization is achieved.
		Blinking	The link is established with transmit and receive activity.

Related CLI Commands

To view the current state of the SCM and verify it is powered on as indicated by the primary or secondary state, use the **show chassis** command.

Removing and Replacing the Memory Module

To remove and replace a memory module:

1. Place the module face up on a flat antistatic surface.
2. Locate the SO-RIMM connector on the rear of the module. See Figure 5.

Figure 5 Memory Module Location

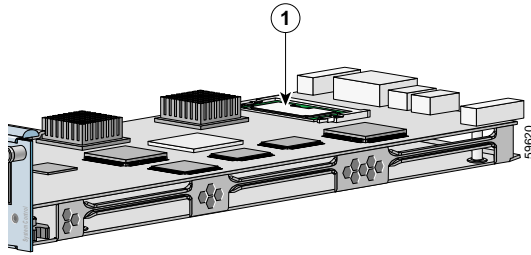

1	Memory module
---	---------------

3. Slightly extend the locking tabs on both sides of the memory module to release it. Gently pull the module out of the connector. See Figure 6.

Figure 6 Memory Replacement

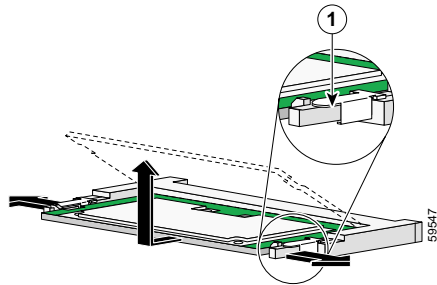

1	SO-RIMM connector tab
---	-----------------------

4. Align the replacement memory module so that the row of gold contacts on the memory module are facing the row of gold pins inside the connector.
5. Insert the memory module into the connector at approximately a 30 degree angle (see Figure 6) and, with gentle pressure, push the module into the connector until the module fits snugly against the back of the connector. At this point, the module is still at an angle *above* the locking tabs.
6. Gently push straight down on the edges of the module until the tabs lock it into place.

