



Cisco 11500 Series Content Services Switch PCMCIA Flash or Hard Disk Reference

The Cisco CSS 11501 chassis and the CSS 11503 and CSS 11506 Switch Control Module (SCM) contain two PCMCIA slots for a hard disk (CSS5-HD=) or Flash disk (CSS5-FD=). These disks contain the CSS software and are used for logging and storing off-line system files. The two disks are identified by the PCMCIA slots (slot 0 and slot 1) in which they are installed. Each replacement disk includes a preinstalled version of the CSS software.



Note

Before you begin, make sure you properly ground yourself prior to handling a disk. For example, wear an antistatic wrist strap (included in the accessory kit with the CSS) and stick the copper-tape end of the strap to an unpainted metal surface on the chassis. Make sure that the wrist strap makes good contact with your skin.



Caution

When removing or installing a hard disk (CSS5-HD=), be sure to gently grasp the hard disk by its sides, not by the top and bottom, to avoid damage. Do not press on the top or bottom of the hard disk.

Removing a PCMCIA Disk

To remove a PCMCIA disk from the CSS:

1. Power down the CSS.
2. Power off the chassis by setting the power switch (or switches) to the **O** (off) position.
3. Locate the failed disk. If necessary, remove the PCMCIA cover (see [Figure 1](#)).



Corporate Headquarters:
Cisco Systems, Inc., 170 West Tasman Drive, San Jose, CA 95134-1706 USA

Copyright © 2003. Cisco Systems, Inc. All rights reserved.

Figure 1 Removing the PCMCIA Cover

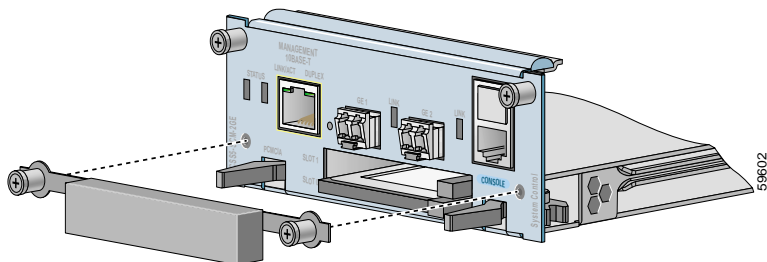

SCM (CSS 11503 or CSS 11506)

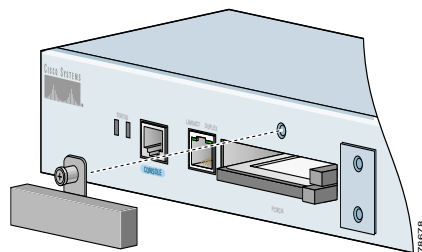

CSS 11501

4. Press the ejector to the right of the disk, and slide the disk out. [Figure 2](#) illustrates ejecting the disk from slot 0.

Figure 2 Ejecting the Disk

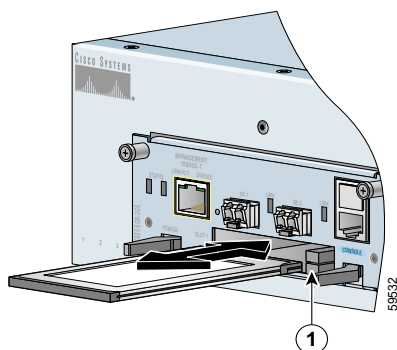

SCM (CSS 11503 or CSS 11506)

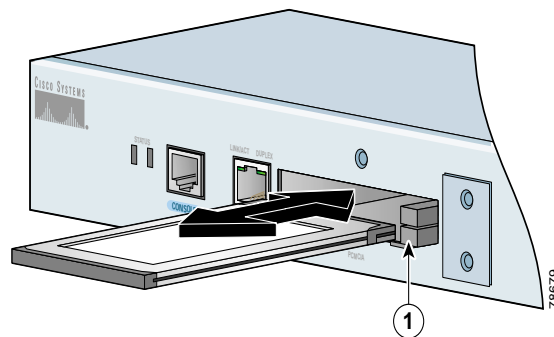

CSS 11501

1	Disk ejector
---	--------------

Installing a PCMCIA Disk

To install a disk (refer to the previous figures):

1. Properly ground yourself prior to handling the disk, as noted on the previous page.
2. Insert the disk in the PCMCIA slot.



Note After you install a disk, you must wait 10 seconds before you can reseal or remove it.

3. With a Phillips screwdriver, replace the PCMCIA disk cover, then tighten the spring-loaded screws.
4. Power on and boot the CSS.
5. If you:
 - Replaced a System disk containing the CSS software, use the Offline Diagnostic Monitor menu to configure a primary location (or secondary location in a two-disk CSS) from which the CSS accesses the boot image. By using the Offline Diagnostic Monitor menu, you can select the software version currently on the new disk, if it is the same software version that was installed on the original disk, or instruct the CSS where to locate a different version of the CSS software ADI file. Refer to the *Cisco Content Services Switch Administration Guide* for details on using the Offline DM menu and on upgrading the CSS software.

**Note**

If you archived a version of the startup-configuration file, use the **restore startup-config** command to restore the file back onto the CSS disk.

- Added a disk for use as a User disk, use the **map** command to configure it. Refer to the *Cisco Content Services Switch Administration Guide* for more information.
- Replaced a User disk containing the log and script files, the Cisco 11500 series CSS automatically recognizes the disk and starts using it.

Related CLI Commands

To view the current state of the newly installed disk and verify that it is online, use the **show disk** command. To view the name of the boot-image on the replacement disk, use the **show installed-software** command.

