



# Memory Module Installation Reference

Product Number: CSS8-SCM-MEM-128M=

The Small Outline Dual Inline Memory Module (SO-DIMM) is a circuit board containing memory chips (DRAMs). This Field Replaceable Unit (FRU) Upgrade kit contains two SO-DIMMs, each containing 64 MB of memory, that replace the 32 MB modules in a CSS 11800 Switch Control Module (SCM).

## Tools You Need

Before you begin, make sure you have the following tools:

- #1 Phillips screwdriver
- Electrostatic Discharge (ESD) wriststrap and wriststrap connector (included in the upgrade kit)

## Installation Considerations

The SCM provides master control and packet memory storage and is responsible for the following functions: system powerup and boot control, centralized routing table management, system-wide connection management, and interface to an external Network Management Station.

### Caution

Before you remove and replace an active SCM, shut down the CSS. If you remove an active SCM from an operational CSS, all communications terminate within the CSS. If there is a passive SCM in the CSS, the CSS reboots. If there is no passive SCM in the CSS, the CSS crashes.

## Tasks to Install the Memory Modules

To install the memory module, perform the following tasks in sequence:

1. If necessary, power down the CSS.
2. Remove the SCM.
3. Install the memory modules.
4. Reinstall the SCM.
5. Power up the CSS.

## Removing the SCM

To remove the SCM:

1. Properly ground yourself prior to handling the module. For example, wear an anti-static wrist strap (included in the upgrade kit) and stick the copper-tape end of the strap to an unpainted metal surface on the chassis. Make sure that the wrist strap makes good contact with your skin.
2. If necessary, power down the CSS.
3. Locate the SCM in the chassis. SCMs are restricted to slots 7 and 8 (slots 7 and 8 are color-coded red). The Active LED is off on a passive SCM. You can remove a passive SCM while the CSS is running. The Active LED is lit on an active SCM. Before removing an active SCM, shutdown the CSS.
4. Using a Phillips screwdriver, loosen the spring-loaded screws on the front of the module faceplate.
5. Grasp the ejectors at the top and bottom of the faceplate, releasing the ejector locks with your index fingers, and open the ejectors simultaneously.
6. Slide the SCM out of the chassis by holding the top and bottom of the faceplate.

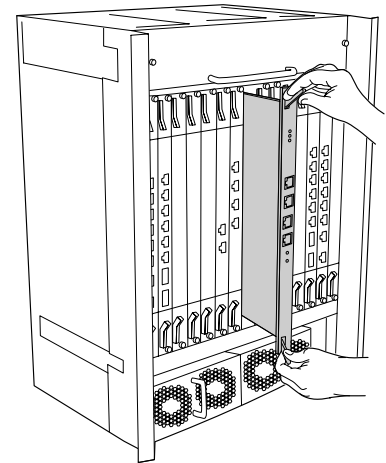

## Installing the Memory Modules

To install a memory module on the SCM:

1. Place the module face up on a flat antistatic surface.
2. Locate the four SO-DIMM connectors on the SCM. Connectors J35 and J37 are already populated; you will be replacing the memory modules in these connectors. Do not use connectors J34 and J36.
3. Slightly extend the locking tabs on both sides of the memory module to release it. Gently pull the module out of the connector.
4. Align the replacement memory module so that the row of gold contacts on the memory module are facing the row of gold pins inside the connector and the notched corner of the module is closest to the edge of the SCM.
5. Insert the memory module into the connector at approximately a 30-degree angle (as shown) and, with gentle pressure, push the module into the connector until the module fits snugly against the back of the connector. At this point, the module is still at an angle *above* the locking tabs.
6. Gently push straight down on the edges of the module until the tabs lock it into place.
7. Repeat Steps 3 through 6 to install the second memory module into the second SO-DIMM connector.

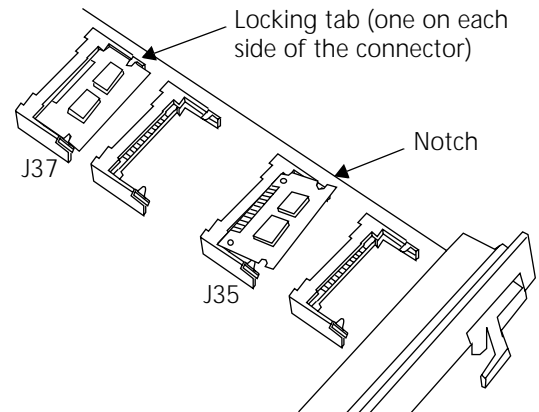

## Reinstalling the SCM

To reinstall the SCM:

1. Insert the SCM back into the board guides at the top and bottom of the slot, then slide it into the chassis by pressing firmly at the top and bottom of the faceplate.
2. Close both ejectors simultaneously to seat the module connector into the backplane.
3. Using a Phillips screwdriver, tighten the spring-loaded screws on the front of the module faceplate (do not overtighten). If you install a passive module, it begins diagnostics and initializes automatically.
4. Power up the CSS.

## Related CLI Commands

To confirm the success of the installation, use the **show system-resources** command.