



# Configuring Dynamic ARP Inspection

This chapter contains the following sections:

- [Information About DAI, on page 1](#)
- [Licensing Requirements for DAI, on page 4](#)
- [Prerequisites for DAI, on page 4](#)
- [Guidelines and Limitations for DAI, on page 5](#)
- [Default Settings for DAI, on page 5](#)
- [Configuring DAI, on page 6](#)
- [Verifying the DAI Configuration, on page 10](#)
- [Monitoring and Clearing DAI Statistics, on page 11](#)
- [Configuration Examples for DAI, on page 11](#)

## Information About DAI

### ARP

ARP provides IP communication within a Layer 2 broadcast domain by mapping an IP address to a MAC address. For example, host B wants to send information to host A but does not have the MAC address of host A in its ARP cache. In ARP terms, host B is the sender and host A is the target.

To get the MAC address of host A, host B generates a broadcast message for all hosts within the broadcast domain to obtain the MAC address associated with the IP address of host A. All hosts within the broadcast domain receive the ARP request, and host A responds with its MAC address.

### ARP Spoofing Attacks

ARP spoofing attacks and ARP cache poisoning can occur because ARP allows a reply from a host even if an ARP request was not received. After the attack, all traffic from the device under attack flows through the attacker's computer and then to the router, switch, or host.

An ARP spoofing attack can affect hosts, switches, and routers connected to your Layer 2 network by sending false information to the ARP caches of the devices connected to the subnet. Sending false information to an ARP cache is known as ARP cache poisoning. Spoof attacks can also intercept traffic intended for other hosts on the subnet.

**Figure 1: ARP Cache Poisoning**

This figure shows an example of ARP cache poisoning.

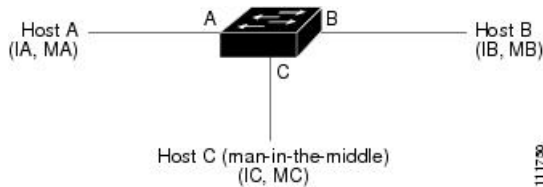

Hosts A, B, and C are connected to the device on interfaces A, B, and C, which are on the same subnet. Their IP and MAC addresses are shown in parentheses; for example, host A uses IP address IA and MAC address MA. When host A needs to send IP data to host B, it broadcasts an ARP request for the MAC address associated with IP address IB. When the device and host B receive the ARP request, they populate their ARP caches with an ARP binding for a host with the IP address IA and a MAC address MA; for example, IP address IA is bound to MAC address MA. When host B responds, the device and host A populate their ARP caches with a binding for a host with the IP address IB and the MAC address MB.

Host C can poison the ARP caches of the device, host A, and host B by broadcasting two forged ARP responses with bindings: one for a host with an IP address of IA and a MAC address of MC and another for a host with the IP address of IB and a MAC address of MC. Host B and the device then use the MAC address MC as the destination MAC address for traffic intended for IA, which means that host C intercepts that traffic. Likewise, host A and the device use the MAC address MC as the destination MAC address for traffic intended for IB.

Because host C knows the true MAC addresses associated with IA and IB, it can forward the intercepted traffic to those hosts by using the correct MAC address as the destination. This topology, in which host C has inserted itself into the traffic stream from host A to host B, is an example of a *man-in-the-middle* attack.

## DAI and ARP Spoofing Attacks

DAI ensures that only valid ARP requests and responses are relayed. When DAI is enabled and properly configured, a Cisco Nexus device performs these activities:

- Intercepts all ARP requests and responses on untrusted ports
- Verifies that each of these intercepted packets has a valid IP-to-MAC address binding before updating the local ARP cache or before forwarding the packet to the appropriate destination
- Drops invalid ARP packets

DAI can determine the validity of an ARP packet based on valid IP-to-MAC address bindings stored in a Dynamic Host Configuration Protocol (DHCP) snooping binding database. This database is built by DHCP snooping if DHCP snooping is enabled on the VLANs and on the device. It can also contain static entries that you create. If the ARP packet is received on a trusted interface, the device forwards the packet without any checks. On untrusted interfaces, the device forwards the packet only if it is valid.

You can configure DAI to drop ARP packets when the IP addresses in the packets are invalid or when the MAC addresses in the body of the ARP packets do not match the addresses specified in the Ethernet header.

## Interface Trust States and Network Security

DAI associates a trust state with each interface on the device. Packets that arrive on trusted interfaces bypass all DAI validation checks, and packets that arrive on untrusted interfaces go through the DAI validation process.

In a typical network configuration, the guidelines for configuring the trust state of interfaces are as follows:

### Untrusted

Interfaces that are connected to hosts

### Trusted

Interfaces that are connected to devices

With this configuration, all ARP packets that enter the network from a device bypass the security check. No other validation is needed at any other place in the VLAN or in the network.



### Caution

Use the trust state configuration carefully. Configuring interfaces as untrusted when they should be trusted can result in a loss of connectivity.

**Figure 2: ARP Packet Validation on a VLAN Enabled for DAI**

The following figure, assume that both device A and device B are running DAI on the VLAN that includes host 1 and host 2. If host 1 and host 2 acquire their IP addresses from the DHCP server connected to device A, only device A binds the IP-to-MAC address of host 1. If the interface between device A and device B is untrusted, the ARP packets from host 1 are dropped by device B and connectivity between host 1 and host 2 is lost.

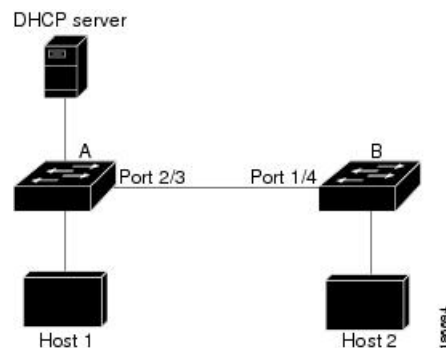

If you configure interfaces as trusted when they should be untrusted, you may open a security hole in a network. If device A is not running DAI, host 1 can easily poison the ARP cache of device B (and host 2, if you configured the link between the devices as trusted). This condition can occur even though device B is running DAI.

DAI ensures that hosts (on untrusted interfaces) connected to a device that runs DAI do not poison the ARP caches of other hosts in the network; however, DAI does not prevent hosts in other portions of the network from poisoning the caches of the hosts that are connected to a device that runs DAI.

If some devices in a VLAN run DAI and other devices do not, the guidelines for configuring the trust state of interfaces on a device that runs DAI becomes the following:

**Untrusted**

Interfaces that are connected to hosts or to devices that *are not* running DAI

**Trusted**

Interfaces that are connected to devices that *are* running DAI

To validate the bindings of packets from devices that do not run DAI, configure ARP ACLs on the device that runs DAI. When you cannot determine the bindings, isolate at Layer 3 the devices that run DAI from devices that do not run DAI.



---

**Note** Depending on your network setup, you may not be able to validate a given ARP packet on all devices in the VLAN.

---

## Logging DAI Packets

Cisco NX-OS maintains a buffer of log entries about DAI packets processed. Each log entry contains flow information, such as the receiving VLAN, the port number, the source and destination IP addresses, and the source and destination MAC addresses.

You can also specify the type of packets that are logged. By default, a Cisco Nexus device logs only packets that DAI drops.

If the log buffer overflows, the device overwrites the oldest DAI log entries with newer entries. You can configure the maximum number of entries in the buffer.



---

**Note** Cisco NX-OS does not generate system messages about DAI packets that are logged.

---

## Licensing Requirements for DAI

This table shows the licensing requirements for DAI.

Product	License Requirement
Cisco NX-OS	DAI requires no license. Any feature not included in a license package is bundled with the Cisco NX-OS system images and is provided at no extra charge to you.

## Prerequisites for DAI

- You must enable the DHCP feature before you can configure DAI.

## Guidelines and Limitations for DAI

DAI has the following configuration guidelines and limitations:

- DAI is an ingress security feature; it does not perform any egress checking.
- DAI is not effective for hosts connected to devices that do not support DAI or that do not have this feature enabled. Because man-in-the-middle attacks are limited to a single Layer 2 broadcast domain, you should separate the domain with DAI from domains without DAI. This separation secures the ARP caches of hosts in the domain with DAI.
- DAI depends on the entries in the DHCP snooping binding database to verify IP-to-MAC address bindings in incoming ARP requests and ARP responses. If you want DAI to use static IP-MAC address bindings to determine if ARP packets are valid, DHCP snooping needs only to be enabled. If you want DAI to use dynamic IP-MAC address bindings to determine if ARP packets are valid, you must configure DHCP snooping on the same VLANs on which you configure DAI.
- When you use the **feature dhcp** command to enable the DHCP feature, there is a delay of approximately 30 seconds before the I/O modules receive the DHCP or DAI configuration. This delay occurs regardless of the method that you use to change from a configuration with the DHCP feature disabled to a configuration with the DHCP feature enabled. For example, if you use the Rollback feature to revert to a configuration that enables the DHCP feature, the I/O modules receive the DHCP and DAI configuration approximately 30 seconds after you complete the rollback.
- DAI is supported on access ports, trunk ports, port-channel ports, and private VLAN ports.
- The DAI trust configuration of a port channel determines the trust state of all physical ports that you assign to the port channel. For example, if you have configured a physical port as a trusted interface and then you add that physical port to a port channel that is an untrusted interface, the physical port becomes untrusted.
- When you remove a physical port from a port channel, the physical port does not retain the DAI trust state configuration of the port channel.
- When you change the trust state on the port channel, the device configures a new trust state on all the physical ports that comprise the channel.
- If you want DAI to use static IP-MAC address bindings to determine if ARP packets are valid, ensure that DHCP snooping is enabled and that you have configured the static IP-MAC address bindings.
- If you want DAI to use dynamic IP-MAC address bindings to determine if ARP packets are valid, ensure that DHCP snooping is enabled.

## Default Settings for DAI

This table lists the default settings for DAI parameters.

**Table 1: Default DAI Parameters**

Parameters	Default
DAI	Disabled on all VLANs.

Parameters	Default
Interface trust state	All interfaces are untrusted.
Validation checks	No checks are performed.
Log buffer	When DAI is enabled, all denied or dropped ARP packets are logged. The number of entries in the log is 32. The number of system messages is limited to 5 per second. The logging-rate interval is 1 second.
Per-VLAN logging	All denied or dropped ARP packets are logged.

## Configuring DAI

### Enabling or Disabling DAI on VLANs

You can enable or disable DAI on VLANs. By default, DAI is disabled on all VLANs.

#### Before you begin

If you are enabling DAI, ensure the following:

- Ensure that the DHCP feature is enabled.
- The VLANs on which you want to enable DAI are configured.

#### Procedure

	Command or Action	Purpose
<b>Step 1</b>	<b>configure terminal</b>  <b>Example:</b> switch# configure terminal switch(config)#	Enters global configuration mode.
<b>Step 2</b>	<b>[no] ip arp inspection vlan list</b>  <b>Example:</b> switch(config)# ip arp inspection vlan 13	Enables DAI for the specified list of VLANs. The <b>no</b> option disables DAI for the specified VLANs.
<b>Step 3</b>	(Optional) <b>show ip arp inspection vlan list</b>  <b>Example:</b> switch(config)# show ip arp inspection vlan 13	Shows the DAI status for the specified list of VLANs.

	Command or Action	Purpose
<b>Step 4</b>	(Optional) <b>copy running-config startup-config</b>  <b>Example:</b> <pre>switch(config)# copy running-config startup-config</pre>	Copies the running configuration to the startup configuration.

## Configuring the DAI Trust State of a Layer 2 Interface

You can configure the DAI interface trust state of a Layer 2 interface. By default, all interfaces are untrusted.

A device forwards ARP packets that it receives on a trusted Layer 2 interface but does not check them.

On untrusted interfaces, the device intercepts all ARP requests and responses and verifies that the intercepted packets have valid IP-MAC address bindings before updating the local cache and forwarding the packet to the appropriate destination. If the device determines that packets have invalid bindings, it drops the packets and logs them according to the logging configuration.

### Before you begin

If you are enabling DAI, ensure that the DHCP feature is enabled.

### Procedure

	Command or Action	Purpose
<b>Step 1</b>	<b>configure terminal</b>  <b>Example:</b> <pre>switch# configure terminal switch(config)#</pre>	Enters global configuration mode.
<b>Step 2</b>	<b>interface</b> <i>type number / slot</i>  <b>Example:</b> <pre>switch(config)# interface ethernet 2/1 switch(config-if)#</pre>	Enters interface configuration mode.
<b>Step 3</b>	<b>[no] ip arp inspection trust</b>  <b>Example:</b> <pre>switch(config-if)# ip arp inspection trust</pre>	Configures the interface as a trusted ARP interface. The <b>no</b> option configures the interface as an untrusted ARP interface.
<b>Step 4</b>	(Optional) <b>show ip arp inspection interface</b> <i>type number / slot</i>  <b>Example:</b> <pre>switch(config-if)# show ip arp inspection interface ethernet 2/1</pre>	Displays the trust state and the ARP packet rate for the specified interface.

	Command or Action	Purpose
<b>Step 5</b>	(Optional) <b>copy running-config startup-config</b>  <b>Example:</b> <pre>switch(config-if)# copy running-config startup-config</pre>	Copies the running configuration to the startup configuration.

## Enabling or Disabling Additional Validation

You can enable or disable additional validation of ARP packets. By default, no additional validation of ARP packets is enabled. When no additional validation is configured, the source MAC address and the source IP address check against the IP-to-MAC binding entry for ARP packets are done by using the Ethernet source MAC address (not the ARP sender MAC address) and the ARP sender IP address.

DAI intercepts, logs, and discards ARP packets with invalid IP-to-MAC address bindings. You can enable additional validation on the destination MAC address, the sender and target IP addresses, and the source MAC address.

You can use the following keywords with the **ip arp inspection validate** command to implement additional validations:

### dst-mac

Checks the destination MAC address in the Ethernet header against the target MAC address in the ARP body for ARP responses. When enabled, packets with different MAC addresses are classified as invalid and are dropped.

### ip

Checks the ARP body for invalid and unexpected IP addresses. Addresses include 0.0.0.0, 255.255.255.255, and all IP multicast addresses. Sender IP addresses are checked in all ARP requests and responses, and target IP addresses are checked only in ARP responses.

### src-mac

Checks the source MAC address in the Ethernet header against the sender MAC address in the ARP body for ARP requests and responses. When enabled, packets with different MAC addresses are classified as invalid and are dropped.

When enabling additional validation, follow these guidelines:

- You must specify at least one of the keywords. You can specify one, two, or all three keywords.
- Each **ip arp inspection validate** command that you enter replaces the configuration from any previous commands. If you enter an **ip arp inspection validate** command to enable src-mac and dst-mac validations, and a second **ip arp inspection validate** command to enable ip validation, the src-mac and dst-mac validations are disabled when you enter the second command.

### Procedure

	Command or Action	Purpose
<b>Step 1</b>	<b>configure terminal</b>  <b>Example:</b>	Enters global configuration mode.



	Command or Action	Purpose
	switch# configure terminal switch(config)#	
<b>Step 2</b>	<b>[no] ip arp inspection validate</b> {[src-mac] [dst-mac] [ip]}  <b>Example:</b> switch(config)# ip arp inspection validate src-mac dst-mac ip	Enables additional DAI validation, or if you use the <b>no</b> option, disables additional DAI validation.
<b>Step 3</b>	(Optional) <b>show running-config dhcp</b>  <b>Example:</b> switch(config)# show running-config dhcp	Displays the DHCP snooping configuration, including the DAI configuration.
<b>Step 4</b>	(Optional) <b>copy running-config startup-config</b>  <b>Example:</b> switch(config)# copy running-config startup-config	Copies the running configuration to the startup configuration.

## Configuring the DAI Logging Buffer Size

You can configure the DAI logging buffer size. The default buffer size is 32 messages.

### Procedure

	Command or Action	Purpose
<b>Step 1</b>	<b>configure terminal</b>  <b>Example:</b> switch# configure terminal switch(config)#	Enters global configuration mode.
<b>Step 2</b>	<b>[no] ip arp inspection log-buffer entries</b> <i>number</i>  <b>Example:</b> switch(config)# ip arp inspection log-buffer entries 64	Configures the DAI logging buffer size. The <b>no</b> option reverts to the default buffer size, which is 32 messages. The buffer size can be between 1 and 1024 messages.
<b>Step 3</b>	(Optional) <b>show running-config dhcp</b>  <b>Example:</b> switch(config)# show running-config dhcp	Displays the DHCP snooping configuration, including the DAI configuration.
<b>Step 4</b>	(Optional) <b>copy running-config startup-config</b>  <b>Example:</b> switch(config)# copy running-config startup-config	Copies the running configuration to the startup configuration.

## Configuring DAI Log Filtering

You can configure how the device determines whether to log a DAI packet. By default, the device logs DAI packets that are dropped.

### Procedure

	Command or Action	Purpose
<b>Step 1</b>	<b>configure terminal</b>  <b>Example:</b> <pre>switch# configure terminal switch(config)#</pre>	Enters global configuration mode.
<b>Step 2</b>	Enter one of the following commands: <ul style="list-style-type: none"> <li>• <b>ip arp inspection vlan <i>vlan-list</i> logging dhcp-bindings all</b></li> <li>• <b>ip arp inspection vlan <i>vlan-list</i> logging dhcp-bindings none</b></li> <li>• <b>ip arp inspection vlan <i>vlan-list</i> logging dhcp-bindings permit</b></li> <li>• <b>no ip arp inspection vlan <i>vlan-list</i> logging dhcp-bindings {all   none   permit}</b></li> </ul> <b>Example:</b> <pre>switch(config)# ip arp inspection vlan 100 dhcp-bindings permit</pre>	Configures DAI log filtering, as follows. The <b>no</b> option removes DAI log filtering. <ul style="list-style-type: none"> <li>• Logs all packets that match DHCP bindings.</li> <li>• Does not log packets that match DHCP bindings.</li> <li>• Logs packets permitted by DHCP bindings.</li> <li>• Removes DAI log filtering.</li> </ul>
<b>Step 3</b>	(Optional) <b>show running-config dhcp</b>  <b>Example:</b> <pre>switch(config)# show running-config dhcp</pre>	Displays the DHCP snooping configuration, including the DAI configuration.
<b>Step 4</b>	(Optional) <b>copy running-config startup-config</b>  <b>Example:</b> <pre>switch(config)# copy running-config startup-config</pre>	Copies the running configuration to the startup configuration.

## Verifying the DAI Configuration

To display the DAI configuration information, perform one of the following tasks.

Command	Purpose
<b>show ip arp inspection</b>	Displays the status of DAI.
<b>show ip arp inspection interface ethernet</b>	Displays the trust state.

Command	Purpose
<code>show ip arp inspection vlan</code>	Displays the DAI configuration for a specific VLAN.
<code>show arp access-lists</code>	Displays ARP ACLs.
<code>show ip arp inspection log</code>	Displays the DAI log configuration.

## Monitoring and Clearing DAI Statistics

### Configuration Examples for DAI

#### Example 1-Two Devices Support DAI

These procedures show how to configure DAI when two devices support DAI.

**Figure 3: Two Devices Supporting DAI**

The following figure shows the network configuration for this example. Host 1 is connected to device A, and Host 2 is connected to device B. Both devices are running DAI on VLAN 1 where the hosts are located. A DHCP server is connected to device A. Both hosts acquire their IP addresses from the same DHCP server. Device A has the bindings for Host 1 and Host 2, and device B has the binding for Host 2. Device A Ethernet interface 2/3 is connected to the device B Ethernet interface 1/4.

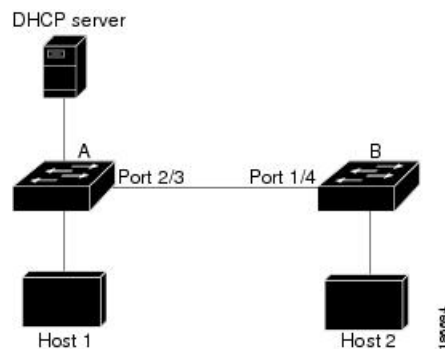

DAI depends on the entries in the DHCP snooping binding database to verify IP-to-MAC address bindings in incoming ARP requests and ARP responses. Make sure to enable DHCP snooping to permit ARP packets that have dynamically-assigned IP addresses.

- This configuration does not work if the DHCP server is moved from device A to a different location.
- To ensure that this configuration does not compromise security, configure Ethernet interface 2/3 on device A and Ethernet interface 1/4 on device B as trusted.

#### Configuring Device A

To enable DAI and configure Ethernet interface 2/3 on device A as trusted, follow these steps:

## Procedure

**Step 1** While logged into device A, verify the connection between device A and device B.

```
switchA# show cdp neighbors
Capability Codes: R - Router, T - Trans-Bridge, B - Source-Route-Bridge
                  S - Switch, H - Host, I - IGMP, r - Repeater,
                  V - VoIP-Phone, D - Remotely-Managed-Device,
                  s - Supports-STP-Dispute
Device ID         Local Intrfce  Hldtme  Capability  Platform      Port ID
switchB          Ethernet2/3   177     R S I       WS-C2960-24TC Ethernet1/4
switchA#
```

**Step 2** Enable DAI on VLAN 1 and verify the configuration.

```
switchA# config t
switchA(config)# ip arp inspection vlan 1
switchA(config)# show ip arp inspection vlan 1
Source Mac Validation      : Disabled
Destination Mac Validation : Disabled
IP Address Validation      : Disabled
Vlan : 1
-----
Configuration      : Enabled
Operation State    : Active
switchA(config)#
```

**Step 3** Configure Ethernet interface 2/3 as trusted.

```
switchA(config)# interface ethernet 2/3
switchA(config-if)# ip arp inspection trust
switchA(config-if)# exit
switchA(config)# exit
switchA# show ip arp inspection interface ethernet 2/3
Interface      Trust State   Rate (pps)   Burst Interval
-----
Ethernet2/3    Trusted       15           5
```

**Step 4** Verify the bindings.

```
switchA# show ip dhcp snooping binding
MacAddress      IpAddress      LeaseSec  Type          VLAN  Interface
-----
00:60:0b:00:12:89  10.0.0.1      0         dhcp-snooping  1    Ethernet2/3
switchA#
```

**Step 5** Check the statistics before and after DAI processes any packets.

```
switchA# show ip arp inspection statistics vlan 1
Vlan : 1
-----
ARP Req Forwarded = 0
ARP Res Forwarded = 0
ARP Req Dropped   = 0
ARP Res Dropped   = 0
DHCP Drops        = 0
DHCP Permits      = 0
SMAC Fails-ARP Req = 0
SMAC Fails-ARP Res = 0
```

```

DMAC Fails-ARP Res = 0
IP Fails-ARP Req  = 0
IP Fails-ARP Res  = 0
switchA#

```

If host 1 sends out two ARP requests with an IP address of 10.0.0.1 and a MAC address of 0002.0002.0002, both requests are permitted, and are shown as follows:

```

switchA# show ip arp inspection statistics vlan 1
Vlan : 1
-----
ARP Req Forwarded = 2
ARP Res Forwarded = 0
ARP Req Dropped   = 0
ARP Res Dropped   = 0
DHCP Drops        = 0
DHCP Permits      = 2
SMAC Fails-ARP Req = 0
SMAC Fails-ARP Res = 0
DMAC Fails-ARP Res = 0
IP Fails-ARP Req  = 0
IP Fails-ARP Res  = 0

```

If host 1 tries to send an ARP request with an IP address of 10.0.0.3, the packet is dropped and an error message is logged.

```

00:12:08: %SW_DAI-4-DHCP_SNOOPING_DENY: 2 Invalid ARPs (Req) on Ethernet2/3, vlan
1. ([0002.0002.0002/10.0.0.3/0000.0000.0000/0.0.0.0/02:42:35 UTC Fri Jul 13 2008])

```

The statistics display as follows:

```

switchA# show ip arp inspection statistics vlan 1
switchA#
Vlan : 1
-----
ARP Req Forwarded = 2
ARP Res Forwarded = 0
ARP Req Dropped   = 2
ARP Res Dropped   = 0
DHCP Drops        = 2
DHCP Permits      = 2
SMAC Fails-ARP Req = 0
SMAC Fails-ARP Res = 0
DMAC Fails-ARP Res = 0
IP Fails-ARP Req  = 0
IP Fails-ARP Res  = 0
switchA#

```

## Configuring Device B

To enable DAI and configure Ethernet interface 1/4 on device B as trusted, follow these steps:

### Procedure

- Step 1** While logged into device B, verify the connection between device B and device A.

```

switchB# show cdp neighbors
Capability Codes: R - Router, T - Trans-Bridge, B - Source-Route-Bridge
                  S - Switch, H - Host, I - IGMP, r - Repeater,
                  V - VoIP-Phone, D - Remotely-Managed-Device,
                  s - Supports-STP-Dispute

Device ID         Local Intrfce   Hldtme   Capability   Platform         Port ID
switchA           Ethernet1/4     120      R S I       WS-C2960-24TC   Ethernet2/3
switchB#

```

### Step 2 Enable DAI on VLAN 1, and verify the configuration.

```

switchB# config t
switchB(config)# ip arp inspection vlan 1
switchB(config)# show ip arp inspection vlan 1
Source Mac Validation      : Disabled
Destination Mac Validation : Disabled
IP Address Validation      : Disabled
Vlan : 1
-----
Configuration      : Enabled
Operation State    : Active
switchB(config)#

```

### Step 3 Configure Ethernet interface 1/4 as trusted.

```

switchB(config)# interface ethernet 1/4
switchB(config-if)# ip arp inspection trust
switchB(config-if)# exit
switchB(config)# exit
switchB# show ip arp inspection interface ethernet 1/4
Interface      Trust State   Rate (pps)   Burst Interval
-----
Ethernet1/4    Trusted       15           5
switchB#

```

### Step 4 Verify the list of DHCP snooping bindings.

```

switchB# show ip dhcp snooping binding
-----
MacAddress      IPAddress      LeaseSec      Type           VLAN  Interface
-----
00:01:00:01:00:01  10.0.0.2      4995         dhcp-snooping  1     Ethernet1/4
switchB#

```

### Step 5 Check the statistics before and after DAI processes any packets.

```

switchB# show ip arp inspection statistics vlan 1
Vlan : 1
-----
ARP Req Forwarded = 0
ARP Res Forwarded = 0
ARP Req Dropped   = 0
ARP Res Dropped   = 0
DHCP Drops        = 0
DHCP Permits      = 0
SMAC Fails-ARP Req = 0
SMAC Fails-ARP Res = 0
DMAC Fails-ARP Res = 0
IP Fails-ARP Req  = 0
IP Fails-ARP Res  = 0
switchB#

```

If Host 2 sends out an ARP request with the IP address 10.0.0.2 and the MAC address 0001.0001.0001, the packet is forwarded and the statistics are updated.

```
switchB# show ip arp inspection statistics vlan 1
Vlan : 1
-----
ARP Req Forwarded = 1
ARP Res Forwarded = 0
ARP Req Dropped   = 0
ARP Res Dropped   = 0
DHCP Drops        = 0
DHCP Permits      = 1
SMAC Fails-ARP Req = 0
SMAC Fails-ARP Res = 0
DMAC Fails-ARP Res = 0
IP Fails-ARP Req   = 0
IP Fails-ARP Res   = 0
switchB#
```

If Host 2 attempts to send an ARP request with the IP address 10.0.0.1, DAI drops the request and logs the following system message:

```
00:18:08: %SW_DAI-4-DHCP_SNOOPING_DENY: 1 Invalid ARPs (Req) on Ethernet1/4, vlan
1. ([0001.0001.0001/10.0.0.1/0000.0000.0000/0.0.0.0/01:53:21 UTC Fri Jun 13 2008])
```

The statistics display as follows:

```
switchB# show ip arp inspection statistics vlan 1
Vlan : 1
-----
ARP Req Forwarded = 1
ARP Res Forwarded = 0
ARP Req Dropped   = 1
ARP Res Dropped   = 0
DHCP Drops        = 1
DHCP Permits      = 1
SMAC Fails-ARP Req = 0
SMAC Fails-ARP Res = 0
DMAC Fails-ARP Res = 0
IP Fails-ARP Req   = 0
IP Fails-ARP Res   = 0
switchB#
```

---

