



## Preparing for Installation

---

This chapter describe how to prepare for the installation of the Cisco ASR 902 Router at your site.

- [Safety Guidelines, on page 1](#)
- [Site Planning, on page 10](#)
- [Receiving the Cisco ASR 902 Router, on page 20](#)

## Safety Guidelines

Before you begin the installation of the Cisco ASR 902 Router, review the safety guidelines in this chapter to avoid injuring yourself or damaging the equipment.

In addition, before replacing, configuring, or maintaining the Cisco ASR 902 Router, review the safety warnings listed in the Product Documentation and Compliance for the Cisco ASR 900 Series Aggregation Services Routers document.

The following sections describe the safety guidelines for the Cisco ASR 902 Router:

## Standard Warning Statements

To see translations of the warnings that appear in this publication, refer to the [Product Documentation and Compliance for the Cisco ASR 900 Series Aggregation Services Routers](#) document.



---

**Warning**

The appliance must be connected to a grounded outlet. Statement 0414

---



---

**Warning**

To avoid or reduce the risk of personal injury, do not use the product if the product has been exposed to irregular environmental conditions, if the product has been misused or if parts of the product have been damaged. Consult qualified service personnel. Never try to service the product yourself. Statement 0416

---



---

**Warning**

To reduce the risk of electric shock, fire or personal injury, do not place power cables in areas where they may be walked on or damaged by items placed upon or against it. Statement 0417

---



**Warning** This product is intended for use in a normal environment based on the standard IEC 60950-1. Do not use the product in vehicles, on board ships, in aircrafts or in medical applications with physical connection to the patient, nor in environments with exposure to moisture, dust, vibration or ingress of water. Statement 0418



**Warning** Do not work on the system or connect or disconnect cables during periods of lightning activity. Statement 1001



**Warning** Read the installation instructions before connecting the system to the power source. Statement 1004



**Warning** To prevent bodily injury when mounting or servicing this unit in a rack, you must take special precautions to ensure that the system remains stable. The following guidelines are provided to ensure your safety: This unit should be mounted at the bottom of the rack if it is the only unit in the rack. When mounting this unit in a partially filled rack, load the rack from the bottom to the top with the heaviest component at the bottom of the rack. If the rack is provided with stabilizing devices, install the stabilizers before mounting or servicing the unit in the rack. Statement 1006



**Warning** This unit is intended for installation in restricted access areas. A restricted access area can be accessed only through the use of a special tool, lock and key, or other means of security. Statement 1017



**Warning** If the symbol of suitability with an overlaid cross appears above a port, you must not connect the port to a public network that follows the European Union standards. Connecting the port to this type of public network can cause severe injury or damage your router. Statement 1031



**Warning** Do not use this product near water; for example, near a bath tub, wash bowl, kitchen sink or laundry tub, in a wet basement, or near a swimming pool. Statement 1035



**Warning** Never install telephone jacks in wet locations unless the jack is specifically designed for wet locations. Statement 1036



**Warning** Never touch uninsulated telephone wires or terminals unless the telephone line has been disconnected at the network interface. Statement 1037



**Warning** Avoid using a telephone (other than a cordless type) during an electrical storm. There may be a remote risk of electric shock from lightning. Statement 1038



**Warning** To report a gas leak, do not use a telephone in the vicinity of the leak. Statement 1039



**Warning** Ultimate disposal of this product should be handled according to all national laws and regulations. Statement 1040



**Warning** To prevent the system from overheating, do not operate it in an area that exceeds the maximum recommended ambient temperature of 149°F (65°C). Statement 1047



**Warning** The chassis should be mounted on a rack that is permanently affixed to the building. Statement 1049



**Warning** IMPORTANT SAFETY INSTRUCTIONS: This warning symbol means danger. You are in a situation that could cause bodily injury. Before you work on any equipment, be aware of the hazards involved with electrical circuitry and be familiar with standard practices for preventing accidents. Use the statement number provided at the end of each warning to locate its translation in the translated safety warnings that accompanied this device. Statement 1071



**Warning** No user-serviceable parts inside. Do not open. Statement 1073



**Warning** This is a Class A Device and is registered for EMC requirements for industrial use. The seller or buyer should be aware of this. If this type was sold or purchased by mistake, it should be replaced with a residential-use type. Statement 294



**Warning** This is a class A product. In a domestic environment this product may cause radio interference in which case the user may be required to take adequate measures. Statement 340



**Warning** This equipment is in compliance with the essential requirements and other relevant provisions of Directive 1999/5/EC. Statement 287

## Safety Guidelines for Personal Safety and Equipment Protection

The following guidelines help ensure your safety and protect the equipment. This list does not include all the potentially hazardous situations. Therefore, you should be on alert.

- Before moving the system, always disconnect all the power cords and interface cables.
- Never assume that power is disconnected from a circuit; always check.
- Before and after installation, keep the chassis area clear and dust free.
- Keep tools and assembly components away from walk areas where you or others could trip over them.
- Do not work alone if potentially hazardous conditions exist.
- Do not perform any action that creates a potential hazard to people or makes the equipment unsafe.
- Do not wear loose clothing that may get caught in the chassis.
- When working under conditions that may be hazardous to your eyes, wear safety glasses.

## Safety Precautions for Module Installation and Removal

Be sure to observe the following safety precautions when you work on the router.

To see the translations of the warnings that appear in this publication, refer to the [Product Documentation and Compliance for the Cisco ASR 900 Series Aggregation Services Routers](#) document.

**Warning**

For connections outside the building where the equipment is installed, the following ports must be connected through an approved network termination unit with integral circuit protection. Statement 1044

**Warning**

Invisible laser radiation may be emitted from disconnected fibers or connectors. Do not stare into beams or view directly with optical instruments. Statement 1051

**Warning**

Class 1M laser radiation when open. Do not view directly with optical instruments. Statement 1053

**Warning**

Class 1 (CDRH) and Class 1M (IEC) laser products. Statement 1055

**Warning**

Do not stare into the beam or view it directly with optical instruments. Statement 1011

**Warning**

Invisible laser radiation present. Statement 1016



---

**Warning** Hazardous network voltages are present in WAN ports regardless of whether power to the unit is OFF or ON. To avoid electric shock, use caution when working near WAN ports. When detaching cables, detach the end away from the unit first. Statement 1026

---



---

**Warning** Blank faceplates and cover panels serve three important functions: they prevent exposure to hazardous voltages and currents inside the chassis; they contain electromagnetic interference (EMI) that might disrupt other equipment; and they direct the flow of cooling air through the chassis. Do not operate the system unless all cards, faceplates, front covers, and rear covers are in place. Statement 1029

---



---

**Warning** Hazardous voltage or energy is present on the backplane when the system is operating. Use caution when servicing. Statement 1034

---



---

**Warning** Invisible laser radiation may be emitted from disconnected fibers or connectors. Do not stare into beams or view directly with optical instruments. Statement 1051

---

## Safety with Electricity



---

**Warning** Before working on a chassis or working near power supplies, unplug the power cord on AC units; disconnect the power at the circuit breaker on DC units. Statement 12

---



---

**Warning** Before working on equipment that is connected to power lines, remove jewelry (including rings, necklaces, and watches). Metal objects will heat up when connected to power and ground and can cause serious burns or weld the metal object to the terminals. Statement 43

---



---

**Warning** To prevent accidental discharge in the event of a power line cross, route on-premise wiring away from power cables and off-premise wiring, or use a grounded shield to separate the on-premise wiring from the power cables and off-premise wiring. A power line cross is an event, such as a lightning strike, that causes a power surge. Off-premise wiring is designed to withstand power line crosses. On-premise wiring is protected from power line crosses by a device that provides overcurrent and overvoltage protection. Nevertheless, if the on-premise wiring is in close proximity to or not shielded from, the off-premise wiring or power cable during a lightning strike or power surge, the on-premise wiring can carry a dangerous discharge to the attached interface, equipment, or nearby personnel. Statement 338

---



**Warning** High leakage current – earth connection essential before connection to system power supply. Statement 342



**Warning** Avoid using or servicing any equipment that has outdoor connections during an electrical storm. There may be a risk of electric shock from lightning. Statement 1088



**Warning** Before performing any of the following procedures, ensure that power is removed from the DC circuit. Statement 1003



**Warning** Read the installation instructions before connecting the system to the power source. Statement 1004



**Warning** This product relies on the building's installation for short-circuit (overcurrent) protection. Ensure that the protective device is rated: For a -48/-60 VDC installation, the wire shall be 12 AWG minimum with a 20 A branch circuit breaker. For a 24 VDC installation, the wire shall be 8 AWG minimum with a 40 A branch circuit breaker. Statement 1005



**Warning** This product relies on the building's installation for short-circuit (overcurrent) protection. For an AC installation, ensure that the branch circuit breaker is rated a maximum 20A. Statement 1005



**Warning** There is the danger of explosion if the battery is replaced incorrectly. Replace the battery only with the same or equivalent type recommended by the manufacturer. Dispose of used batteries according to the manufacturer's instructions. Statement 1015



**Warning** This unit is intended for installation in restricted access areas. A restricted access area can be accessed only through the use of a special tool, lock and key, or other means of security. Statement 1017



**Warning** Take care when connecting units to the supply circuit so that wiring is not overloaded. Statement 1018



**Warning** The plug-socket combination must be accessible at all times, because it serves as the main disconnecting device. Statement 1019



**Warning** To avoid electric shock, do not connect safety extra-low voltage (SELV) circuits to telephone-network voltage (TNV) circuits. LAN ports contain SELV circuits, and WAN ports contain TNV circuits. Some LAN and WAN ports both use RJ45 connectors. Use caution when connecting cables. Statement 1021



**Warning** A readily accessible two-poled disconnect device must be incorporated in the fixed wiring. Statement 1022



**Warning** To reduce the risk of fire, use only 26 AWG or larger telecommunication line cord. Statement 1023



**Warning** This equipment must be grounded. Never defeat the ground conductor or operate the equipment in the absence of a suitably installed ground conductor. Contact the appropriate electrical inspection authority or an electrician if you are uncertain that suitable grounding is available. Statement 1024



**Warning** Use copper conductors only. Statement 1025



**Warning** Hazardous network voltages are present in WAN ports regardless of whether power to the unit is OFF or ON. To avoid electric shock, use caution when working near WAN ports. When detaching cables, detach the end away from the unit first. Statement 1026



**Warning** This unit might have more than one power supply connection. All connections must be removed to de-energize the unit. Statement 1028



**Warning** To prevent personal injury or damage to the chassis, never attempt to lift or tilt the chassis using the handles on modules (such as power supplies, fans, or cards); these types of handles are not designed to support the weight of the unit. Statement 1032



**Warning** Connect the unit only to DC power source that complies with the safety extra-low voltage (SELV) requirements in IEC 60950 based safety standards. Statement 1033



**Warning** Do not use this product near water; for example, near a bath tub, wash bowl, kitchen sink or laundry tub, in a wet basement, or near a swimming pool. Statement 1035



---

**Warning** Never install telephone jacks in wet locations unless the jack is specifically designed for wet locations. Statement 1036

---



---

**Warning** Before opening the unit, disconnect the telephone-network cables to avoid contact with telephone-network voltages. Statement 1041

---



---

**Warning** This product requires short-circuit (overtuned) protection, to be provided as part of the building installation. Install only in accordance with national and local wiring regulations. Statement 1045

---



---

**Warning** When installing or replacing the unit, the ground connection must always be made first and When you connect or disconnect the power and/or alarm connector with power applied, an electrical arc can occur. This could cause an explosion in hazardous area installations. Be sure that all power is removed from the switch and any other circuits. Be sure that power cannot be accidentally turned on or verify that the area is nonhazardous before proceeding. Statement 1058

---



---

**Warning** Installation of the equipment must comply with local and national electrical codes. Statement 1074

---



---

**Warning** If you connect or disconnect the console cable with power applied to the switch or any device on the network, an electrical arc can occur. This could cause an explosion in hazardous location installations. Be sure that power is removed or the area is nonhazardous before proceeding. Statement 1080

---



---

**Warning** Hazardous voltage or energy may be present on power terminals. Always replace cover when terminals are not in service. Be sure uninsulated conductors are not accessible when cover is in place. Statement 1086

---

When working on equipment powered by electricity, follow these guidelines:

- Locate the room's emergency power-off switch. If an electrical accident occurs, you will be able to quickly turn off the power.
- Before starting work on the system, turn off the DC main circuit breaker and disconnect the power terminal block cable.
- Before doing the following, disconnect all power:
  - Working on or near power supplies
  - Installing or removing a router chassis or network processor module
  - Performing most hardware upgrades
- Never install equipment that appears damaged.



- Carefully examine your work area for possible hazards, such as moist floors, ungrounded power extension cables, and missing safety grounds.
- Never assume that power is disconnected from a circuit; always check.
- Never perform any action that creates a potential hazard to people or makes the equipment unsafe.
- If an electrical accident occurs, proceed as follows:
  - Use caution, and do not become a victim yourself.
  - Turn off power to the router.
  - If possible, send another person to get medical aid. Otherwise, determine the condition of the victim, and then call for help.
  - Determine whether the person needs rescue breathing or external cardiac compressions; then take appropriate action.

In addition, use the following guidelines when working with any equipment that is disconnected from a power source, but still connected to telephone wiring or network cabling:

- Never install telephone wiring during a lightning storm.
- Never install telephone jacks in wet locations unless the jack is specifically designed for it.
- Never touch uninsulated telephone wires or terminals unless the telephone line is disconnected at the network interface.
- When installing or modifying telephone lines, use caution.

## Power Supply Considerations

Check the power at your site to ensure that you are receiving clean power (free of spikes and noise). Install a power conditioner, if necessary.



---

**Warning** This equipment has been designed for connection to TN and IT power systems. Statement 1007

---

## Preventing ESD Damage



---

**Warning** This equipment needs to be grounded. Use a green and yellow 6 AWG ground wire to connect the host to earth ground during normal use. Statement 383

---

Electrostatic discharge (ESD) can damage equipment and impair electrical circuitry. ESD may occur when electronic printed circuit cards are improperly handled and can cause complete or intermittent failures. When removing and replacing modules, always follow ESD prevention procedures:

- Ensure that the router chassis is electrically connected to earth ground.
- Wear an ESD-preventive wrist strap, ensuring that it makes good skin contact. To channel unwanted ESD voltages safely to ground, connect the clip to an unpainted surface of the chassis frame. To guard against ESD damage and shocks, the wrist strap and cord must operate effectively.
- If no wrist strap is available, ground yourself by touching a metal part of the chassis.
- When installing a component, use any available ejector levers or captive installation screws to properly seat the bus connectors in the backplane or midplane. These devices prevent accidental removal, provide proper grounding for the system, and help to ensure that bus connectors are properly seated.

- When removing a component, use available ejector levers or captive installation screws, if any, to release the bus connectors from the backplane or midplane.
- Handle components by their handles or edges only; do not touch the printed circuit boards or connectors.
- Place a removed component board side up on an antistatic surface or in a static-shielding container. If you plan to return the component to the factory, immediately place it in a static-shielding container.
- Avoid contact between the printed circuit boards and clothing. The wrist strap only protects components from ESD voltages on the body; ESD voltages on clothing can still cause damage.
- Never attempt to remove the printed circuit board from the metal carrier.



---

**Note** For the safety of your equipment, periodically check the resistance value of the antistatic wrist strap. It should be between 1 and 10 Mohm.

---

## Site Planning

The following sections describe how to plan for the installation of the Cisco ASR 902 Router:

### General Precautions

Observe the following general precautions when using and working with your Cisco ASR 902 Router system:

- Keep your system components away from radiators and heat sources and do not block cooling vents.
- Do not spill food or liquids on your system components and never operate the product in a wet environment.
- Do not push any objects into the openings of your system components. Doing so can cause fire or electric shock by shorting out interior components.
- Position system cables and power supply cable carefully. Route system cables and the power supply cable and plug so that they are not stepped on or tripped over. Be sure that nothing else rests on your system component cables or power cable.
- Do not modify power cables or plugs. Consult a licensed electrician or your power company for site modifications. Always follow your local and national wiring rules.
- If you turn off your system, wait at least 30 seconds before turning it on again to avoid damage of system components.

### Site Planning Checklist

Use the following checklist to perform and account for all the site planning tasks described in this chapter:

- The site meets the environmental requirements.
- The site's air conditioning system can compensate for the heat dissipation of the Cisco ASR 902 Router.
- The floor space that the Cisco ASR 902 Router occupies can support the weight of the system.
- Electrical service to the site complies with the requirements.
- The electrical circuit servicing the Cisco ASR 902 Router complies with the requirements.
- Consideration has been given to the console port wiring and limitations of the cabling involved, according to TIA/EIA-232F.
- The Cisco ASR 902 Router Ethernet cabling distances are within the prescribed limitations.

- The equipment rack in which you plan to install the Cisco ASR 902 Router complies with prescribed requirements.
- When selecting the location of the rack, careful consideration must be given to safety, ease of maintenance, and proper airflow.

## Site Selection Guidelines

The Cisco ASR 902 Router requires specific environmental operating conditions. Temperature, humidity, altitude, and vibration can affect the performance and reliability of the router. The following sections provide specific information to help you plan for the proper operating environment.

The Cisco ASR 902 Router is designed to meet the industry EMC, safety, and environmental standards described in the Product Documentation and Compliance for the Cisco ASR 900 Series Aggregation Services Routers document.

### Environmental Requirements

The Cisco ASR 902 Router is Telcordia GR-3108-CORE Class-1/GR-63-Core Indoor compliant. Environmental monitoring of the Cisco ASR 902 Router protects the system and components from damage caused by excessive voltage and temperature conditions. To ensure normal operation and avoid unnecessary maintenance, plan and prepare your site configuration *before* installation. After installation, make sure that the site maintains the environmental characteristics described in the [System Specifications](#).

For an outside plant installation (cell site cabinet, hut etc.), it is required that the Cisco ASR 902 Router be protected against airborne contaminants, dust, moisture, insects, pests, corrosive gases, polluted air or other reactive elements present in the outside air. To achieve this level of protection, we recommend that the unit be installed in a fully sealed enclosure or cabinet. Examples of such cabinets include IP65 cabinets with heat exchanger complying with Telcordia GR487. Temperature must be maintained within  $-40^{\circ}\text{C}$  to  $65^{\circ}\text{C}$ .

### Physical Characteristics

Be familiar with the physical characteristics of the Cisco ASR 902 Router to assist you in placing the system in the proper location. For more information, see the [System Specifications](#).

## Air Flow Guidelines

Cool air is circulated through the Cisco ASR 902 Router by a fan tray located along the right side of the router.

The fan tray maintains acceptable operating temperatures for the internal components by drawing in cool air through the vents, and circulating the air through the chassis.

The following guidelines will help you plan your equipment rack configuration:

- For horizontal mounting—Air flow is side to side and right to left, as shown in the figure below. To ensure adequate air flow through the equipment rack, we recommend that you maintain a clearance of at least 80 mm on each side of the rack at all times.

Figure 1: Cisco ASR 902 Router Chassis Air Flow - Horizontal Mounting

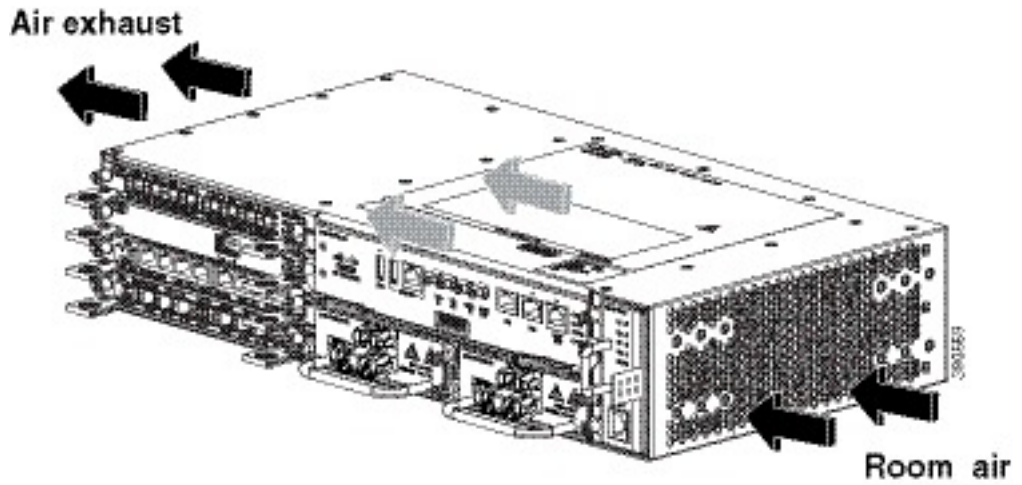

- For vertical mounting—Air flow is bottom to top, as shown in the figure below . To ensure adequate air flow through the equipment rack, we recommend that you maintain a clearance of at least 80 mm (X) on top and 100 mm (Y) at bottom of the rack at all times.



**Caution**

When mounting the router vertically, ensure that the fan tray is at the bottom to ensure bottom-to-top air flow.

Figure 2: Cisco ASR 902 Router Chassis Air Flow - Vertical Mounting

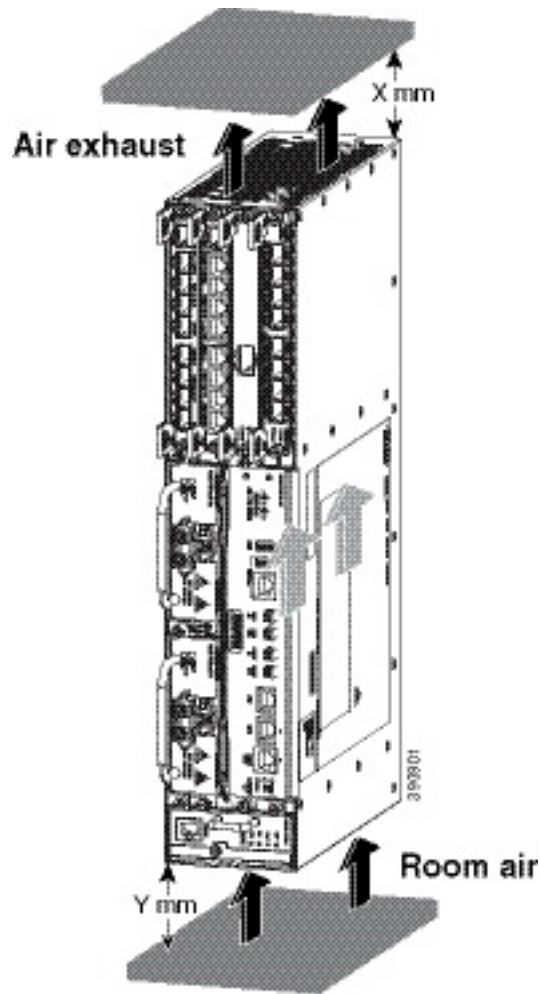

- If airflow through the equipment rack and the routers that occupy it is blocked or restricted, or if the ambient air being drawn into the rack is too warm, an overtemperature condition may occur within the rack and the routers that occupy it.
- The site should also be as dust-free as possible. Dust tends to clog the router fans, reducing the flow of cooling air through the equipment rack and the routers that occupy it, thus increasing the risk of an overtemperature condition.
- Enclosed racks must have adequate ventilation. Ensure that the rack is not congested because each router generates heat. An enclosed rack should have louvered sides and a fan to provide cooling air. Heat that is generated by the equipment near the bottom of the rack can be drawn upward into the intake ports of the equipment above.
- When mounting a chassis in an open rack, ensure that the rack frame does not block the side intakes and the exhaust fans.
- When rack-installed equipment fails, especially equipment in an enclosed rack, try operating the equipment by itself, if possible. Power off all the other equipment in the rack (and in adjacent racks) to give the router maximum cooling air and clean power.

- Avoid locating the Cisco ASR 902 Router in a location in which the chassis air intake vents may draw in the exhaust air from adjacent equipment. Consider how the air flows through the router; the airflow direction is side to side, with ambient air drawn in from the vents located on the front right of the chassis.

## Air Flow Guidelines for Enclosed Rack Installation

To install a Cisco ASR 902 Router in a 4-post enclosed cabinet, the front and rear doors of the cabinet must be removed or be perforated with a minimum of 65% open area (70% for ETSI 800-mm racks).

If you are mounting the chassis in a 4-post enclosed cabinet, ensure that you have a minimum of 6 inches (15.24 cm) of clearance on each side of the chassis.

## Floor Loading Considerations

Ensure that the floor under the rack supporting the Cisco ASR 902 Routers is capable of supporting the combined weight of the rack and all the other installed equipment.

To assess the weight of a fully configured Cisco ASR 902 Router, refer to the [System Specifications](#).

For additional information about floor loading requirements, see the [GR-63-CORE, Network Equipment Building System \(NEBS\) Requirements: Physical Protection](#) document.

## Site Power Guidelines

The Cisco ASR 902 Router has specific power and electrical wiring requirements. Adhering to these requirements ensures reliable operation of the system. Follow these precautions and recommendations when planning your site power for the Cisco ASR 902 Router:

- The redundant power option provides a second, identical power supply to ensure that power to the chassis continues uninterrupted if one power supply fails or input power on one line fails.
- In systems configured with the redundant power option, connect each of the two power supplies to separate independent power source. If you fail to do this, your system might be susceptible to total power failure due to a fault in the external wiring or a tripped circuit breaker.
- To prevent a loss of input power, be sure that the total maximum load on each circuit supplying the power supplies is within the current ratings of the wiring and the breakers.
- Check the power at your site before installation, and periodically after installation to ensure that you are receiving clean power. Install a power conditioner, if necessary.
- Provide proper grounding to avoid personal injury and damage to the equipment due to lightning striking power lines or due to power surges. The chassis ground must be attached to a central office or other interior ground system.



---

**Caution**

This product requires short-circuit (overcurrent) protection to be provided as part of the building installation. Install only in accordance with national and local wiring regulations.

---



**Note** The Cisco ASR 902 Router installation must comply with all the applicable codes, and is approved for use with copper conductors only. The ground bond-fastening hardware should be of compatible material and preclude loosening, deterioration, and electrochemical corrosion of hardware and joined material. Attachment of the chassis ground to a central office or other interior ground system must be made with a 6-AWG gauge wire copper ground conductor at a minimum.

The table below lists the maximum power draw of the Cisco ASR 902 Router chassis and its configurable hardware components. The maximum power-draw values are not affected by whether the router chassis contains 1 or 2 power supplies and if AC or DC.

**Table 1: Maximum Power Draw For Cisco ASR 902 Router Chassis**

Hardware Component	Maximum Power Draw Value
A900-RSP2A-64	70 W
A900-RSP2A-128	100 W
A900-RSP3-200-S	160 W
A900-IMA1X (1-port 10 Gigabit Ethernet XFP interface module)	13.0 W
A900-IMA8T (8-port 1 Gigabit Ethernet RJ45 interface module)	17.5 W
A900-IMA8S (8-port 1 Gigabit Ethernet SFP interface module)	17.5 W
A900-IMA16D (16-port T1/E1 interface module)	14.5 W
A900-IMA4OS (4-Port OC3 interface module)	26 W
A900-IMA8S1Z (8-port 1GE SFP + 1-port 10 GE interface module)	29 W
A900-IMA8T1Z (8-port 1GE RJ-45 Copper + 1 10 GE interface module)	27 W
A900-IMA8Z (8-port 10 Gigabit Ethernet Interface Module)	60 W
A900-IMA2F (2-port 40 Gigabit Ethernet QSFP Interface Module)	60 W
A900-IMA2Z (2-port 10 GE interface module)	24 W
A900-IMASER14A/S (14-port Serial Interface Module)	20 W
A900-IMA6EM (6-port E & M Interface Module)	20 W
A900-IMA4C3794 (4-port C37.94 Interface Module)	14 W
A900-IMAG703FXSO (G.703/FXS/FXO Interface Module)	27 W

## Electrical Circuit Requirements

Each Cisco ASR 902 Router requires a dedicated electrical circuit. If you equip the router with dual-power feeds, provide a separate circuit for each power supply to avoid compromising the power redundancy feature.

The Cisco ASR 902 Routers can be powered by a DC source or an AC source. Ensure that equipment grounding is present and observe the power-strip ratings. Make sure that the total ampere rating of all the products plugged into the power strip does not exceed 80% of the rating.

For more information about the Cisco ASR 902 Router power supply, see the [Power Supply Features](#).

## Site Cabling Guidelines

This section contains guidelines for wiring and cabling at your site. When preparing your site for network connections to the Cisco ASR 902 Router, consider the type of cable required for each component, and the cable limitations. Consider the distance limitations for signaling, electromagnetic interference (EMI), and connector compatibility. Possible cable types are fiber, thick or thin coaxial, foil twisted-pair, or unshielded twisted-pair cabling.

Also consider any additional interface equipment you need, such as transceivers, hubs, switches, modems, channel service units (CSU), or data service units (DSU).

Before you begin, read these important notes about cabling:

- The T1/E1 interface module for the Cisco ASR 902 Router uses a high-density connector that requires the use of a T1/E1 interface cable and a customer-provided patch panel. For more information, see the [Connecting T1/E1 Cables](#) section.
- Shielded cables must be used to connect to the RJ45 alarm connector on the fan tray in order to comply with FCC/EN55022/CISPR22 Class A emission requirements. For information about the fan tray alarm port, see the [Connecting the Fan Tray Alarm Port](#) section .

Before you install the Cisco ASR 902 Router, have all the additional external equipment and cables on hand. For information about ordering, contact a Cisco customer service representative.

The extent of your network and the distances between the network interface connections depend, in part, on the following factors:

- Signal type
- Signal speed
- Transmission medium

The distance and rate limits referenced in the following sections are the IEEE-recommended maximum speeds and distances for signaling purposes. Use this information as a guideline when planning your network connections *>prior to* installing the Cisco ASR 902 Router.

If wires exceed the recommended distances, or if wires pass between buildings, give special consideration to the effect of a lightning strike in your vicinity. The electromagnetic pulse caused by lightning or other high-energy phenomena can easily couple enough energy into unshielded conductors to destroy electronic devices. If you have had problems of this sort in the past, you may want to consult experts in electrical surge suppression and shielding.

## Asynchronous Terminal Connections

The RSP provides a console port to connect a terminal or computer for local console access. The port has an RJ45 connector and supports RS-232 asynchronous data with distance recommendations specified in the IEEE RS-232 standard.



## Interference Considerations

When wires are run for any significant distance, there is a risk that stray signals will be induced on the wires as interference. If interference signals are strong, they may cause data errors or damage to the equipment.

The following sections describe the sources of interference and how to minimize their effects on the Cisco ASR 902 Router system.

### Electromagnetic Interference

All the equipment powered by AC current can propagate electrical energy that can cause EMI and possibly affect the operation of other equipment. The typical sources of EMI are equipment power cords and power service cables from electric utility companies.

Strong EMI can destroy the signal drivers and receivers in the Cisco ASR 902 Router and even create an electrical hazard by causing power surges through the power lines into installed equipment. These problems are rare, but could be catastrophic.

To resolve these problems, you need specialized knowledge and equipment that could consume substantial time and money. However, you can ensure that you have a properly grounded and shielded electrical environment, paying special attention to the need for electrical surge suppression.

For information about the electromagnetic compliance standards supported on the Cisco ASR 902 Router, see the [Product Documentation and Compliance for the Cisco ASR 900 Series Aggregation Services Routers](#) document.

### Radio Frequency Interference

When electromagnetic fields act over a long distance, radio frequency interference (RFI) may be propagated. Building wiring can often act as an antenna, receiving the RFI signals and creating more EMI on the wiring.

If you use twisted-pair cable in your plant wiring with a good distribution of grounding conductors, the plant wiring is unlikely to emit radio interference. If you exceed the recommended distances, use a high-quality twisted-pair cable with one ground conductor for each data signal.

### Lightning and AC Power Fault Interference

If signal wires exceed the recommended cabling distances, or if signal wires pass between buildings, you should consider the effect that a lightning strike in your vicinity might have on the Cisco ASR 902 Router.

The electromagnetic pulse (EMP) generated by lightning or other high-energy phenomena can couple enough energy into unshielded conductors to damage or destroy electronic equipment. If you have previously experienced such problems, you should consult with RFI and EMI experts to ensure that you have adequate electrical surge suppression and shielding of signal cables in your Cisco ASR 902 Router operating environment.

## Rack-Mounting Guidelines

The following sections provide guidelines for rack-mounting the Cisco ASR 902 Router:

### Precautions for Rack-Mounting

The following rack-mount guidelines are provided to ensure your safety:

- Ensure that the rack is level and stable before extending a component from the rack.
- Ensure that proper airflow is provided to the components in the rack.

- Do not step on or stand on any component or system when servicing other systems or components in a rack.
- When mounting the Cisco ASR 902 Router in a partially filled rack, load the rack from the bottom to the top, with the heaviest component at the bottom of the rack.
- If the rack is provided with stabilizing devices, install the stabilizers before mounting or servicing the unit in the rack.

## Rack Selection Guidelines

The Cisco ASR 902 Router can be mounted in most two-post or four-post, 19-inch equipment racks that comply with the Electronic Industries Association (EIA) standard for equipment racks (EIA-310-D 19-inch). The rack must have at least two posts with mounting flanges to mount the chassis.



### Caution

When mounting a chassis in any type of rack equipment, ensure that the inlet air to the chassis does not exceed 65°C.

The distance between the center lines of the mounting holes on the two mounting posts must be 18.31 inch  $\pm$  0.06 inch (46.50 cm  $\pm$  0.15 cm). The rack-mounting hardware included with the chassis is suitable for most 19-inch equipment racks.

Consider installing the Cisco ASR 902 Router in a rack with the following features:

- NEBS-compliant, 19-inch wide (48.3-cm) rack.
- EIA or European Telecommunications Standards Institute (ETSI) hole patterns in the mounting rails. The required mounting hardware is shipped with the Cisco ASR 902 Router. If the rack that you plan to install the system in has metric-threaded rails, you must provide your own metric-mounting hardware.
- Perforated top and open bottom for ventilation to prevent overheating.
- Leveling feet for stability.



### Caution

The Cisco ASR 902 Router should *not* be installed in an enclosed rack because the chassis requires an unobstructed flow of cooling air to maintain acceptable operating temperatures for its internal components. Installing the router in any type of enclosed rack—even with the side doors removed—could disrupt the air flow, trap heat next to the chassis, and cause an overtemperature condition inside the router. If you use an enclosed rack, ensure that there are air vents on all sides of the rack and there is proper ventilation.

## Equipment Rack Guidelines

The placement of a rack can affect personnel safety, system maintenance, and the system's ability to operate within the environmental characteristics described in the System Specifications. Choose a proper location for the Cisco ASR 902 Router by following the guidelines described here.

### Locating for Safety

If the Cisco ASR 902 Router is the heaviest or the only piece of equipment in the rack, consider installing it at or near the bottom to ensure that the rack's center of gravity is as low as possible.

For additional information about the proper placement of electronic equipment, consult the [GR-63-CORE, Network Equipment Building System \(NEBS\) Requirements: Physical Protection](#) document.

### Locating for Easy Maintenance

Keep at least 3 feet of clear space at the front and back of the rack. This space ensures that you can remove the Cisco ASR 902 Router components and perform routine maintenance and upgrades easily.

Avoid installing the Cisco ASR 902 Router in a congested rack and consider how routing of cables from other pieces of equipment in the same rack could affect access to the router cards.

The sides of the chassis must remain unobstructed to ensure adequate airflow and prevent overheating inside the chassis.

Allow the following clearances for normal system maintenance:

- At the top of the chassis—At least 3 inches (7.6 cm)
- Sides of the chassis—3 to 4 ft (91.44 cm to 121.92 cm)

To avoid problems during installation and ongoing operations, follow these general precautions when you plan equipment locations and connections:

- Use the **show environment all** command regularly to check the internal system status. The environmental monitor continually checks the interior chassis environment; it provides warnings about high temperature and creates reports on other potentially dangerous occurrences. If warning messages are displayed, take immediate action to identify the cause, and correct the problem.
- Keep the Cisco ASR 902 Router off the floor and out of areas that collect dust.
- Follow ESD-prevention procedures to avoid damage to equipment. Damage from static discharge can cause immediate or intermittent equipment failure.

### Locating for Proper Airflow

Ensure that the Cisco ASR 902 Router location has enough airflow to keep the system operating within the environmental characteristics and the air temperature is sufficient to compensate for the heat dissipated by the system. For more information, see the [Air Flow Guidelines](#) section.

## Installation Checklist

To assist you with your installation and to provide a record of what was done by whom and when, photocopy the Cisco ASR 902 Router Installation Checklist shown in the table below . Use this to record the completion and verification of each procedure. After the checklist is completed, place it in your Site Log along with the other records pertaining to your new Cisco router.

**Table 2: Cisco ASR 902 Router Installation Checklist**

Task	Verified By	Date
Date on which chassis received		
Chassis and all accessories unpacked		
Types and numbers of interfaces verified		
Safety recommendations and guidelines reviewed		
Installation Checklist copied		
Site Log established and background information entered		

Task	Verified By	Date
Site power voltages verified		
Site environmental specifications verified		
Required passwords, IP addresses, device names, and so on, available		
Required tools available		
Network connection equipment available		
Cable-management brackets installed (optional, but recommended)		
AC power cables connected to AC sources and router		
DC power cables connected to DC sources and router		
Network interface cables and devices connected		
System power turned on		
System boot complete (STATUS LED is on)		
Interface Module are operational		
Correct software configuration displayed after system banner appears		

## Creating a Site Log

The Site Log provides a record of all the actions related to installing and maintaining the router. Keep it in an accessible place near the chassis so that anyone who performs tasks has access to it.

Create the Site Log prior to the installation. (See [Site Log](#) for more information about the Site Log as well as a sample Site Log that can be used to make copies.)

## Receiving the Cisco ASR 902 Router

Each Cisco ASR 902 Router chassis is shipped in a container that is strapped to a pallet, as illustrated in the figure below.

Figure 3: Cisco ASR 902 Router Packaged for Shipping

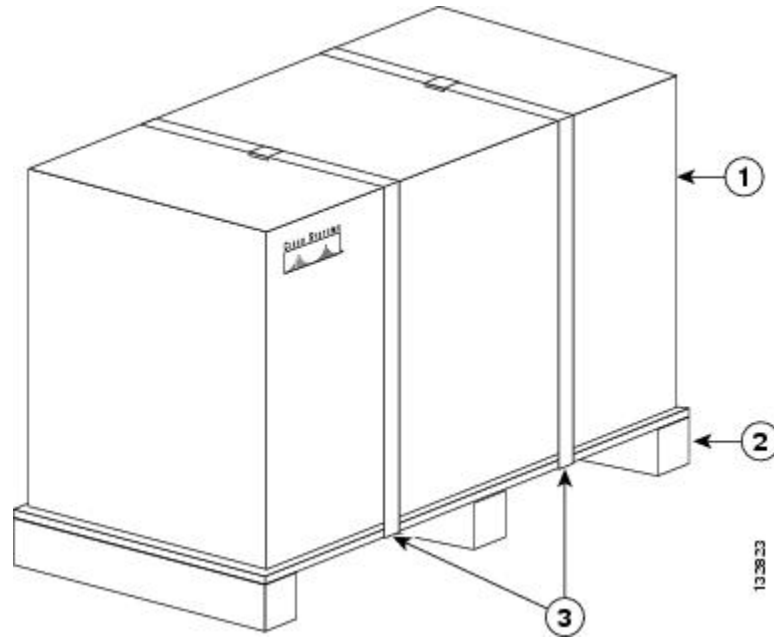

Label	Description	Label	Description
1	Outside carton	3	Packing straps
2	Pallet		

## Chassis-Lifting Guidelines

The chassis is not intended to be moved frequently. Before you install the system, ensure that your site is properly prepared so that you can avoid having to move the chassis later to accommodate power sources and network connections.

Each time you lift the chassis or any heavy object, follow these guidelines:

- Ensure that your footing is solid, and balance the weight of the chassis between your feet.
- Lift the chassis slowly; never move suddenly or twist your body as you lift.
- Keep your back straight and lift with your legs, not your back. If you must bend down to lift the chassis, bend at the knees, not at the waist, to reduce the strain on your back muscles.
- Do not remove installed components from the chassis.
- Always disconnect all external cables before lifting or moving the chassis.



**Warning**

To prevent personal injury or damage to the chassis, never attempt to lift or tilt the chassis using the handles on modules (such as power supplies, fans, or cards); these types of handles are not designed to support the weight of the unit. Statement 1032

## Tools and Equipment

You need the following tools and equipment to install and upgrade the router and its components:

- ESD-preventive cord and wrist strap
- Antistatic mat or antistatic foam
- Number 1 and Number 2 Phillips-head screwdrivers
- Flat-blade screwdrivers: Small 3/16-inch (0.476 cm) and medium 1/4-inch (0.625 cm):
  - To install or remove modules
  - To remove the cover if you are upgrading the memory or other components
- #12-24 pan-head screws to secure the router to the equipment rack
- Cables for connecting to the WAN and LAN ports (depending on the configuration)



---

**Note** For more information about cable specifications, see [Troubleshooting](#).

---

- Ethernet hub, switch, or PC with a network interface card for connecting to the Ethernet ports
- Console terminal (an ASCII terminal or a PC running terminal emulation software) that is configured for 9600 baud, 8 data bits, no parity, and 2 stop bits
- Console cable for connecting to the console port
- (Optional) Modem for connecting to the auxiliary port for remote administrative access
- Auxiliary cable for connecting to the auxiliary port (you can supply this cable or order one)
- Ratcheting torque screwdriver with a Phillips head that exerts up to 30-pound force per square inch (in-lb) or 0.02-kilograms force per square millimeter (kgf/mm<sup>2</sup>) of pressure
- Crimping tool as specified by the ground lug manufacturer
- Wire-stripping tools for stripping both 8-AWG and 12-AWG wires
- Tape measure and level



---

**Warning** Only trained and qualified personnel should be allowed to install, replace, or service this equipment. Statement 1030

---

## Unpacking and Verifying the Shipped Contents

When you receive your chassis, perform the following steps:

1. Inspect the box for any shipping damage. If there is obvious physical damage, contact your Cisco service representative.
2. Unpack the Cisco ASR 902 Router.
3. Perform a visual inspection of the chassis.
4. Use the table below to check the contents of the Cisco ASR 902 Router shipping container. Do not discard the shipping container. You will need the container if you move or ship the Cisco ASR 902 Router in the future.

Table 3: Cisco ASR 902 Router Shipping Container Contents

Component	Description
Chassis	Cisco ASR 902 Router chassis
	Fan tray
	Power supplies
	RSP
	Interface modules
Accessories kit	Chassis rack-mount brackets (19-inch EIA)
	Three sets of screws: <ul style="list-style-type: none"> <li>• Front and rear rack-mount bracket screws (2 sets)</li> <li>• Cable-management bracket screws</li> </ul>
	Six cable-management brackets (one per bracket)
	One earth lug with two 10-32 screws.
	1 RJ45 to RJ45 crossover cable
	1 RJ45 to DB-9 (female) adapter
ESD, wrist strap (disposable)	One disposable wrist strap (optional)
Documentation	Cisco ASR 900 Series Aggregation Service Router Documentation
Optional equipment	Check the container for the following optional equipment: <ul style="list-style-type: none"> <li>• Power cord if an AC power supply was shipped. There are no cords for the DC power supply units.</li> <li>• T1/E1 cable connector (required only for T1/E1 interface modules)</li> </ul>



**Note** Most Cisco documentation is available online. The Cisco ASR 900 Series Aggregation Service Router Documentation that is shipped with your Cisco ASR 902 Router contains links and information about the various documents that are available online.

