



Cisco NCS 1004 Overview

This chapter provides an overview of the Cisco Network Convergence Series (NCS) 1004.

- [Cisco NCS 1004 Features, on page 1](#)
- [Interoperability with Cisco NCS 1001, on page 1](#)
- [Supported Line Cards, on page 2](#)
- [1.2T Card Interoperability with OTN-XP Card, on page 4](#)

Cisco NCS 1004 Features

Cisco NCS 1004 is a two RU unit that supports up to 4.8 Tbps traffic. The NCS 1004 has two redundant, field replaceable AC and DC power supply units and three redundant, field replaceable fans. It also provides a field replaceable controller card. The NCS 1004 has SSD disks both on board the chassis and on the controller card for resiliency. Each NCS 1004 chassis provides four line card slots. Each NCS 1004 slot can host a line card. See [Supported Line Cards, on page 2](#) for more information.

The NCS 1004 delivers the following benefits:

- Transport of any trunk rate from 150 200 to 600 Gbps wavelengths in 50 Gbps increments on the same platform through software provisioning.
- Support of granular control of baud-rate and modulation format to maximize spectral efficiency.
- One universal transponder that is optimized for performance for metro, long-haul, and submarine applications.
- Support for up to 350,000 ps/nm of residual chromatic dispersion compensation.
- Transport of 100GE and OTU4 client rates on the same platform through software provisioning.
- 600G DWDM, which provides unparalleled scale and density. 64 channels of 600G at 75 GHz providing 38.4 Tbps in 16 RU.
- State-of-the-art AES-256 encryption at scale – 4.8 Tbps of encrypted trunk capacity per 2 RU.

Interoperability with Cisco NCS 1001

When the Cisco NCS 1001 with Protection Switching Module (PSM) configured as non-revertive, interoperates with Cisco NCS 1004, traffic loss may occur. After the traffic has switched from the working to the protect

path, do not perform a manual switch for 120 seconds. If you perform a manual switch, and the protect path fails, traffic loss of up to 13 seconds can occur.



Note PSM switching with x50G is not supported as the switching time is more than 50 ms.

Supported Line Cards

The following line cards are supported on Cisco NCS 1004.

NCS1K4-1.2T-K9 C-Band Line Card

The NCS1K4-1.2T-K9 (or 1.2 Tbps) C-band line card has 12 QSFP-28 based clients and two DWDM trunk ports. The trunk ports are capable of several line rates with fine control of modulation format, baud-rate, and forward error correction. The trunk ports are software configurable. The line card supports module and slice configurations.



Note "1.2TC" refers to the NCS1K4-1.2T-K9 C-band line card.

The features of the 1.2T line card are:

- The card provides up to 12 100G or OTU4 client ports.
- The baud rate can be controlled between 28 Gbd/s and 72 Gbd/s.
- The frequency range is 191.25 to 196.1 THz with a default value of 193.1 THz.
- The modulation format can be QPSK, 8 QAM, 16 QAM, 32 QAM, or 64 QAM.
- Hybrid modulations formats can be configured through 1/128 bits/symbol granularity.
- Forward Error Correction (FEC) of 27% and 15% overhead across line rates (only 15% for 600G).
- In Release 7.1.1, the trunk line rate can be configured from 150G to 600G in 50G increments.
- In Release 7.2.1 and later releases, the trunk line rate can be configured from 50G to 600G in 50G increments.

NCS1K4-OTN-XP Line Card

From R7.2.1 onwards, NCS 1004 supports the NCS1K4-OTN-XP card with 100G grey-optics support.



Note "OTN-XP" refers to the NCS1K4-OTN-XP line card.

The OTN-XP card contains:

- Eight QSFP 28 ports
- Four QSFP-DD ports

- Two CFP2 ports

The OTN-XP card supports up to 1.6Tbps of OTN aggregation switching functionality to optimize the available bandwidth. A single line card supports 8x100GE muxponder or 2x400 GE transponder applications. The OTN-XP card supports 400GE/OTUC4, 100GE/OTU4, 10GE/OTU2/OTU2e, 16G FC, and 32G FC client rates.

For more information on the mode configuration, see [Muxponder Configuration on OTN-XP Card](#).

NCS1K4-2-QDD-C-K9 C-Band Line Card

From R7.3.1 onwards, NCS 1004 supports the NCS1K4-2-QDD-C-K9 (or 2-QDD-C) C-Band line card. The card has eight client ports (QSFP28 and QSFP-DD) and two DWDM dual sub-channel module trunk ports. The FR4 and AOC are the two optics supported on the 400GE client ports. Each trunk port is capable of 200, 300, and 400 Gbps line rate with fine control of modulation format, baud-rate, and forward error correction. The trunk ports are software configurable. The line card supports module and slice configurations.



Note "2-QDD-C" refers to the NCS1K4-2-QDD-C-K9 C-band line card.

The features of the 2-QDD-C line card are:

- The card provides up to eight 100 GE or two 400 GE client ports.
- The trunk line rate can be configured from 200G to 400G in 100G increments.



Note The trunk line rates of 250G and 350G are not supported in R7.3.1.

- The client to trunk port mapping is based on type of configuration and the line rate.
- The modulation format can be controlled between QPSK, 8 QAM, and 16 QAM including hybrid modulation.
- Hybrid modulations formats can be configured through 1/128 bits/symbol granularity.
- Forward Error Correction (FEC) of Soft Decision FEC 27% and Soft Decision FEC 15%.
- The baud rate can be controlled between 28 Gbd/s and 72 Gbd/s.
- The frequency range is 191.25 to 196.1 THz with a default value of 193.1 THz.

NCS1K4-QXP-K9 3.2T QSFP-DD DCO Transponder Line Card

From R7.7.1 onwards, NCS 1004 supports the NCS1K4-QXP-K9 (or QXP) Line Card. The card has eight client ports (QSFP-DD) and eight trunk ports (QSFP-DD ZR+).



Note "QXP" refers to the NCS1K4-QXP-K9 C-band line card.

The features of the QXP line card are:

- Each line card supports up to 3.2 Tbps traffic.
- A single line card supports 6 slices of:
 - 4x100GE (breakout) clients in muxponder mode.
 - 400GE clients in transponder mode.
 - 100GE clients in transponder mode.
- The client rates that are supported are 400GE, 4x100GE, and 100GE Ethernet only.
- The modulation formats supported are 16 QAM for 400GE Txp/4x100GE Mxp and QPSK for 100GE Txp.

1.2T Card Interoperability with OTN-XP Card

The OTN-XP card can be interoperable with the 1.2T card. In an interoperability scenario, the 1.2T card can serve as a trunk port and the OTN-XP card can serve as a client port. The trunk port of OTN-XP can converge 10 x 10 G traffic and transmit as 100G traffic in the OTU4 mode. This OTU4 traffic can further be multiplexed to a higher bandwidth DWDM signal by connecting to 1.2T OTU4 client interface.

Trunk-side supported pluggables for the OTN-XP card

For interoperability with the 1.2T card, the supported pluggables are inserted in the OTN-XP card.

The OTN-XP card supports the Cisco QSFP-100G-LR4 Pluggable Optics Module (ONS-QSFP28-LR4) on the trunk side. Ensure that you use the same pluggable on the client side of the 1.2T card.

Client-side supported pluggables for the OTN-XP card

The OTN-XP card supports the following pluggables from its client side connection:

- ONS-QSFP-4x10-MLR
- QSFP-40G-SR4

Prerequisites for Interoperability with OTN-XP Card

- Configure the OTN-XP card in the 10x10G traffic mode.
- Configure the 1.2T card in the OTU4 client mode with supported trunk rate.
- Ensure that the software installed on both route processors and cards are stable in the supported traffic modes for the 1.2T and OTN-XP card.

Scenario on Interoperability with OTN-XP Card

Consider a topology, where the OTN-XP card is configured in the 10x10G traffic mode and 1.2T card is configured in the OTU4 client mode with supported trunk rate.

For the solution to work, the OTN-XP trunk optics performs seamless interoperability with 1.2T client optics.

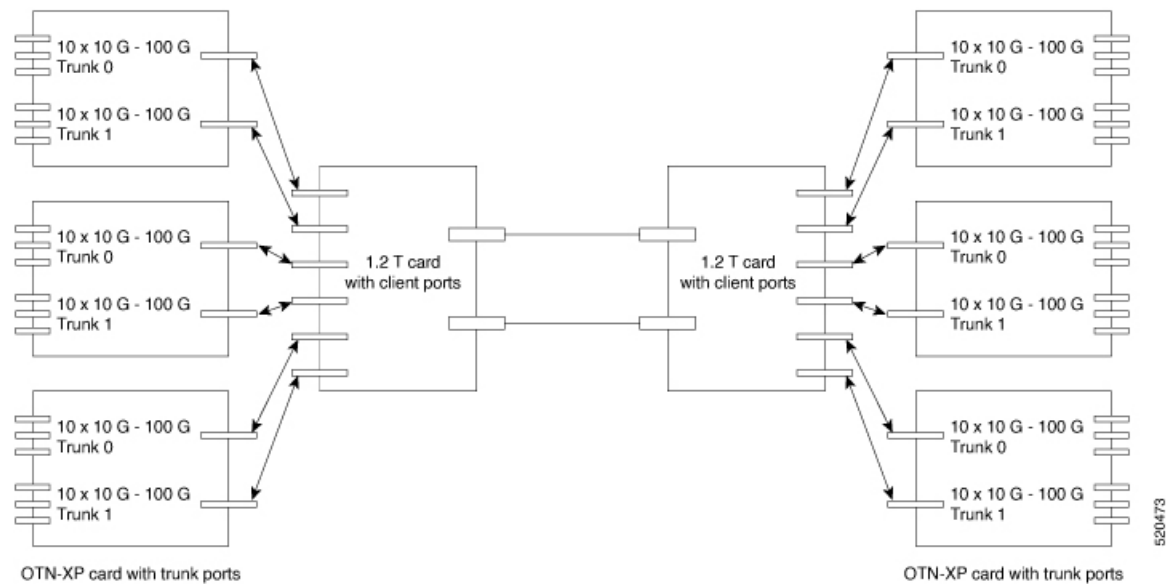

Configure Interoperability between 1.2T Card with OTN-XP Card

To configure interoperability, perform the following steps:

1. Configure the muxponder mode on the 1.2T card, see [Configuring the Card Mode](#).
2. Configure the LC mode on the OTN-XP card, see [Configuring the LC Mode](#).
3. Configure the OTN-XP card in the muxponder mode, see [Configuring the Muxponder Mode for 10G Grey Muxponder](#).
4. Perform no shut on both trunk ports, use the following commands:

```
controller Optics R/S/I/P
no shut
```

The following is a sample to perform no shut on the trunk port:

```
RP/0/RP0/CPU0:ios#configure
RP/0/RP0/CPU0:ios(config)#controller Optics 0/1/0/0
RP/0/RP0/CPU0:ios(config-Optics)#no shut
RP/0/RP0/CPU0:ios(config-Optics)#description trunk port
RP/0/RP0/CPU0:ios(config-Optics)#exit
RP/0/RP0/CPU0:ios(config)#exit
```



Note Ensure that there are no alarms generated and link recovery after events such as fiber cut, card reload, pluggable Online Insertion and Removal (OIR), and re-provisions.

You can perform the following controller specific configurations on the OTN-XP card grey optics and 1.2T OTU4 client optics:

- Loopback
- Trail Trace Identifier (TTI)

- Maintenance
- Performance Monitoring (PM) enable
- Threshold