



Layer 2 Local Switching

The Layer 2 Local Switching feature allows you to switch Layer 2 data in two ways:

- Between two interfaces on the same router
- Between two circuits on the same interface port, which is called same-port switching

The following interface-to-interface switching combinations are supported by this feature:

- ATM to ATM
- ATM to Ethernet
- Ethernet/Ethernet VLAN to Ethernet/Ethernet VLAN
- Frame Relay to Frame Relay

The following same-port switching features are supported:

- ATM Permanent Virtual Circuit (PVC) and Permanent Virtual Path (PVP)
- Ethernet VLAN
- Frame Relay

- [Finding Feature Information, page 2](#)
- [Prerequisites for Layer 2 Local Switching, page 2](#)
- [Restrictions for Layer 2 Local Switching, page 2](#)
- [Information About Layer 2 Local Switching, page 2](#)
- [How to Configure Layer 2 Local Switching, page 3](#)
- [Configuration Examples for Layer 2 Local Switching, page 14](#)
- [Additional References, page 17](#)
- [Feature Information for Layer 2 Local Switching, page 19](#)

Finding Feature Information

Your software release may not support all the features documented in this module. For the latest caveats and feature information, see [Bug Search Tool](#) and the release notes for your platform and software release. To find information about the features documented in this module, and to see a list of the releases in which each feature is supported, see the feature information table at the end of this module.

Use Cisco Feature Navigator to find information about platform support and Cisco software image support. To access Cisco Feature Navigator, go to www.cisco.com/go/cfn. An account on Cisco.com is not required.

Prerequisites for Layer 2 Local Switching

You must enable Cisco Express Forwarding for the Cisco ASR 1000 Series Aggregation Services Router.

Restrictions for Layer 2 Local Switching

- For Ethernet/Ethernet VLAN circuits, the Cisco ASR 1000 Series Aggregation Services Router must have Ethernet Adapters.
- For Frame Relay local switching, you must globally issue the **frame-relay switching** command.

Information About Layer 2 Local Switching

Layer 2 Local Switching Overview

Local switching allows you to switch Layer 2 data between two interfaces of the same type (for example, Ethernet to Ethernet or Frame Relay to Frame Relay) or between interfaces of different types (for example, Ethernet VLAN to Ethernet VLAN or Ethernet to Ethernet VLAN) on the same router. The interfaces can be on the same line card or on two different cards. During these kinds of switching, the Layer 2 address is used, not the Layer 3 address.

Additionally, same-port local switching allows you to switch Layer 2 data between two circuits on the same interface.

NSF SSO—Local Switching Overview

Nonstop forwarding (NSF) and stateful switchover (SSO) improve the availability of the network by providing redundant Route Processors and checkpointing of data to ensure minimal packet loss when the primary Route Processor goes down. NSF/SSO support is available for the following locally switched attachment circuits:

- Ethernet/Ethernet VLAN to Ethernet/Ethernet VLAN
- Frame Relay to Frame Relay

Layer 2 Local Switching Applications

Incumbent local exchange carriers (ILECs) that use an interexchange carrier (IXC) to carry traffic between two local exchange carriers can use the Layer 2 Local Switching feature. Telecom regulations require the ILECs to pay the IXCs to carry that traffic. At times, the ILECs cannot terminate customer connections that are in different local access and transport areas (LATAs). In other cases, customer connections terminate in the same LATA, which may also be on the same router.

For example, company A has more than 50 LATAs across the country and uses three routers for each LATA. Company A uses companies B and C to carry traffic between local exchange carriers. Local switching of Layer 2 frames on the same router might be required.

Similarly, if a router is using, for example, a channelized interface, it might need to switch incoming and outgoing traffic across two logical interfaces that reside on a single physical port. The same-port local switching feature addresses that implementation.

The figure below shows a network that uses local switching for both Frame Relay to Frame Relay and ATM to Frame Relay local switching.

Figure 1: Local Switching Example

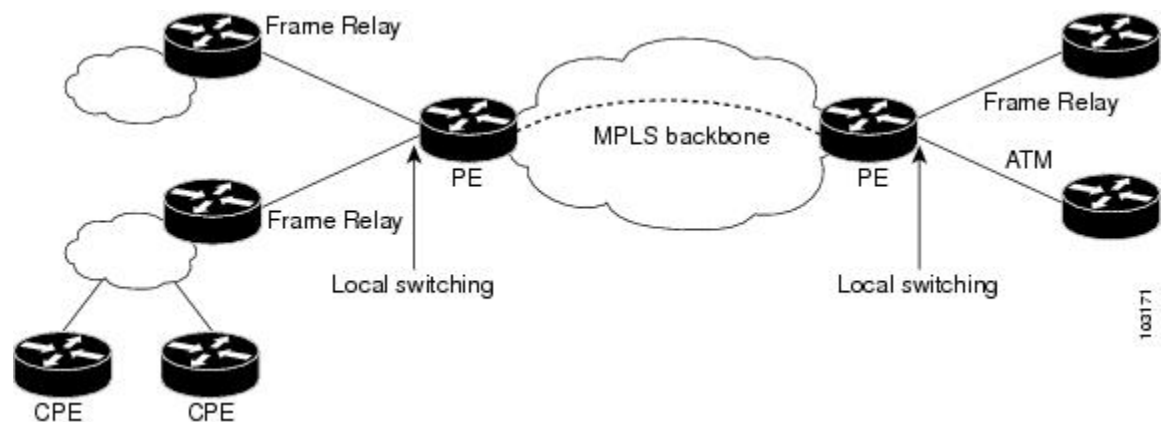

How to Configure Layer 2 Local Switching

Configuring Ethernet VLAN Same-Port Switching

Perform this task to configure Ethernet VLAN same-port switching.

SUMMARY STEPS

1. **enable**
2. **configure terminal**
3. **interface fastethernet** *slot / port . subinterface-number*
4. **encapsulation dot1q** *vlan-id*
5. **exit**
6. **interface fastethernet** *slot / port . subinterface-number*
7. **encapsulation dot1q** *vlan-id*
8. **exit**
9. **connect** *connection-name type number type number*

DETAILED STEPS

	Command or Action	Purpose
Step 1	enable Example: Router> enable	Enables privileged EXEC mode. <ul style="list-style-type: none"> • Enter your password if prompted.
Step 2	configure terminal Example: Router# configure terminal	Enters global configuration mode.
Step 3	interface fastethernet <i>slot / port . subinterface-number</i> Example: Router(config)# interface fastethernet6/0.1	Specifies the first Fast Ethernet line card, subslot (if available), port, and subinterface, and enters subinterface configuration mode.
Step 4	encapsulation dot1q <i>vlan-id</i> Example: Router(config-subif)# encapsulation dot1q 10	Enables the subinterface to accept 802.1Q VLAN packets and specifies the first VLAN.
Step 5	exit Example: Router(config-subif)# exit	Exits subinterface configuration mode and returns to global configuration mode.

	Command or Action	Purpose
Step 6	interface fastethernet <i>slot / port . subinterface-number</i> Example: Router(config)# interface fastethernet6/0.2	Specifies the second Fast Ethernet line card, subslot (if available), port, and subinterface, and enters subinterface configuration mode.
Step 7	encapsulation dot1q <i>vlan-id</i> Example: Router(config-subif)# encapsulation dot1q 20	Enables the subinterface to accept 802.1Q VLAN packets and specifies the second VLAN.
Step 8	exit Example: Router(config-subif)# exit	Exits subinterface configuration mode and returns to global configuration mode.
Step 9	connect <i>connection-name type number type number</i> Example: Router(config)# connect conn fastethernet 6/0.1 fastethernet 6/0.2	Creates a local connection between the two subinterfaces (and hence their previously specified VLANs) on the same Fast Ethernet port.

Configuring Ethernet Port Mode to Ethernet VLAN Local Switching

Perform this task to configure local switching for Ethernet (port mode) to Ethernet VLAN.

SUMMARY STEPS

1. **enable**
2. **configure terminal**
3. **interface fastethernet** *slot / subslot / port*
4. **interface fastethernet** *slot / port / subinterface-number*
5. **encapsulation dot1q** *vlan-id*
6. **exit**
7. **connect** *connection-name type number type number*

DETAILED STEPS

	Command or Action	Purpose
Step 1	enable Example: Router> enable	Enables privileged EXEC mode. <ul style="list-style-type: none"> • Enter your password if prompted.
Step 2	configure terminal Example: Router# configure terminal	Enters global configuration mode.
Step 3	interface fastethernet slot / subslot / port Example: Router(config)# interface fastethernet3/0/0	Specifies a Fast Ethernet line card, subslot (if available), and port, and enters interface configuration mode. <ul style="list-style-type: none"> • This is the interface on one side of the PE router that passes Ethernet packets to and from the customer edge (CE) router.
Step 4	interface fastethernet slot / port / subinterface-number Example: Router(config-if)# interface fastethernet6/0/0.1	Specifies a Fast Ethernet line card, subslot (if available), port, and subinterface, and enters subinterface configuration mode. <ul style="list-style-type: none"> • This is the interface on the other side of the PE router than passes Ethernet VLAN packets to and from the CE router.
Step 5	encapsulation dot1q vlan-id Example: Router(config-subif)# encapsulation dot1q 100	Enables the interface to accept 802.1Q VLAN packets.
Step 6	exit Example: Router(config-subif)# exit	Exits subinterface configuration mode and returns to global configuration mode.
Step 7	connect connection-name type number type number Example: Router(config)# connect eth-ethvlan-con fastethernet 3/0/0 fastethernet 6/0/0.1	Creates a local connection between the two interfaces.

Configuring ATM-to-ATM PVC Local Switching and Same-Port Switching

You can configure local switching for both ATM AAL5 and ATM AAL0 encapsulation types.

Creating the ATM PVC is not required. If you do not create a PVC, one is created for you. For ATM-to-ATM local switching, the autoprovisioned PVC is given the default encapsulation type AAL0 cell relay.

SUMMARY STEPS

1. **enable**
2. **configure terminal**
3. **interface atm slot / port**
4. **pvc vpi / vci l2transport**
5. **encapsulation layer-type**
6. **exit**
7. **exit**
8. **connect connection-name interface pvc interface pvc**

DETAILED STEPS

	Command or Action	Purpose
Step 1	enable Example: Router> enable	Enables privileged EXEC mode. • Enter your password if prompted.
Step 2	configure terminal Example: Router# configure terminal	Enters global configuration mode.
Step 3	interface atm slot / port Example: Router(config)# interface atm1/0/0	Specifies an ATM line card, subslot (if available), and port, and enters interface configuration mode.
Step 4	pvc vpi / vci l2transport Example: Router(config-if)# pvc 1/100 l2transport	Assigns a VPI and VCI and enters ATM PVC l2transport configuration mode. • The l2transport keyword indicates that the PVC is a switched PVC instead of a terminated PVC.
Step 5	encapsulation layer-type Example: Router(cfg-if-atm-l2trans-pvc)# encapsulation aal5	Specifies the encapsulation type for the ATM PVC. Both AAL0 and AAL5 are supported. • Repeat Steps 3 through 5 for another ATM PVC on the same router.

	Command or Action	Purpose
Step 6	exit Example: Router(cfg-if-atm-l2trans-pvc)# exit	Exits PVC l2transport configuration mode and returns to interface configuration mode.
Step 7	exit Example: Router(config-if)# exit	Exits interface configuration mode and returns to global configuration mode.
Step 8	connect <i>connection-name interface pvc interface pvc</i> Example: Router(config)# connect atm-con atm1/0/0 1/100 atm2/0/0 1/100	Creates a local connection between the two specified permanent virtual circuits.

Configuring ATM-to-ATM PVP Local Switching

Perform this task to configure ATM-to-ATM PVP local switching.

Starting with Cisco IOS Release 12.0(30)S, you can configure same-port switching, as detailed in the [Configuring ATM PVP Same-Port Switching](#), on page 9.

SUMMARY STEPS

1. **enable**
2. **configure terminal**
3. **interface atm** *slot/port*
4. **atm pvp** *vpi l2transport*
5. **exit**
6. **exit**
7. **connect** *connection-name interface pvp interface pvp*

DETAILED STEPS

	Command or Action	Purpose
Step 1	enable Example: Router> enable	Enables privileged EXEC mode. <ul style="list-style-type: none"> • Enter your password if prompted.

	Command or Action	Purpose
Step 2	configure terminal Example: Router# configure terminal	Enters global configuration mode.
Step 3	interface atm slot/port Example: Router(config)# interface atm1/0	Specifies an ATM line card, subslot (if available), and port and enters interface configuration mode.
Step 4	atm pvp vpi l2transport Example: Router(config-if)# atm pvp 100 l2transport	Identifies the virtual path and enters PVP l2transport configuration mode. The l2transport keyword indicates that the PVP is a switched PVP instead of a terminated PVP. <ul style="list-style-type: none"> Repeat Steps 3 and 4 for another ATM permanent virtual path on the same router.
Step 5	exit Example: Router(config-if-atm-l2trans-pvp)# exit	Exits PVP l2transport configuration mode and returns to interface configuration mode.
Step 6	exit Example: Router(config-if)# exit	Exits interface configuration mode and returns to global configuration mode.
Step 7	connect connection-name interface pvp interface pvp Example: Router(config)# connect atm-con atm1/0 100 atm2/0 200	Creates a local connection between the two specified permanent virtual paths.

Configuring ATM PVP Same-Port Switching

Perform this task to configure ATM PVP switching on an ATM interface.

SUMMARY STEPS

1. **enable**
2. **configure terminal**
3. **interface atm slot / subslot / port**
4. **atm pvp vpi l2transport**
5. **exit**
6. **exit**
7. **connect connection-name interface pvp interface pvp**

DETAILED STEPS

	Command or Action	Purpose
Step 1	enable Example: Router> enable	Enables privileged EXEC mode. • Enter your password if prompted.
Step 2	configure terminal Example: Router# configure terminal	Enters global configuration mode.
Step 3	interface atm slot / subslot / port Example: Router(config)# interface atm1/0/0	Specifies an ATM line card, subslot (if available), and port, and enters interface configuration mode.
Step 4	atm pvp vpi l2transport Example: Router(config-if)# atm pvp 100 l2transport	Specifies one VPI and enters PVP l2transport configuration mode. Repeat this step for the other ATM permanent virtual path on this same port. • The l2transport keyword indicates that the indicated PVP is a switched PVP instead of a terminated PVP.
Step 5	exit Example: Router(config-if-atm-l2trans-pvp)# exit	Exits PVP l2transport configuration mode and returns to interface configuration mode.
Step 6	exit Example: Router(config-if)# exit	Exits interface configuration mode and returns to global configuration mode.

	Command or Action	Purpose
Step 7	connect <i>connection-name interface pvp interface pvp</i> Example: <pre>Router(config)# connect atm-con atm1/0/0 100 atm1/0/0 200</pre>	In global configuration mode, creates the local connection between the two specified permanent virtual paths.

Configuring Frame Relay-to-Frame Relay Local Switching

For information about Frame Relay-to-Frame Relay local switching, see the Distributed Frame Relay Switching feature module.

SUMMARY STEPS

1. **enable**
2. **configure terminal**
3. **ip cef distributed**
4. **frame-relay switching**
5. **interface** *type number*
6. **encapsulation frame-relay** [*cisco | ietf*]
7. **frame-relay interface-dlci** *dlci* **switched**
8. **exit**
9. **exit**
10. **connect** *connection-name interface dlci interface dlci*

DETAILED STEPS

	Command or Action	Purpose
Step 1	enable Example: <pre>Router> enable</pre>	Enables privileged EXEC mode. <ul style="list-style-type: none"> • Enter your password if prompted.
Step 2	configure terminal Example: <pre>Router# configure terminal</pre>	Enters global configuration mode.

	Command or Action	Purpose
Step 3	ip cef distributed Example: Router(config)# ip cef distributed	Enables Cisco Express Forwarding operation.
Step 4	frame-relay switching Example: Router(config)# frame-relay switching	Enables PVC switching on a Frame Relay DCE device or a Network-to-Network Interface (NNI).
Step 5	interface type number Example: Router(config)# interface serial 0	Specifies a Frame Relay interface and enters interface configuration mode.
Step 6	encapsulation frame-relay [cisco ietf] Example: Router(config-if)# encapsulation frame-relay	Enables Frame Relay encapsulation. <ul style="list-style-type: none"> • The default is cisco encapsulation. • You do not need to specify an encapsulation type.
Step 7	frame-relay interface-dlci dlci switched Example: Router(config-if)# frame-relay interface-dlci 100 switched	(Optional) Creates a switched PVC and enters Frame Relay DLCI configuration mode. <ul style="list-style-type: none"> • Repeat Steps 5 through 7 for each switched PVC. • If you do not create a Frame Relay PVC in this step, it will automatically be created by the connect command.
Step 8	exit Example: Router(config-fr-dlci)# exit	Exits Frame Relay DLCI configuration mode and returns to interface configuration mode.
Step 9	exit Example: Router(config-if)# exit	Exits interface configuration mode and returns to global configuration mode.
Step 10	connect connection-name interface dlci interface dlci Example: Router(config)# connect connection1 serial0 100 serial1 101	Defines a connection between Frame Relay PVCs.

Verifying Layer 2 Local Switching

Verifying Layer 2 Local Switching Configuration

To verify configuration of the Layer 2 local switching feature, use the **show connection** command on the provider edge (PE) router.

SUMMARY STEPS

1. **show connection** [**all** | *element* | **id** *id* | **name** *name* | **port** *port*]

DETAILED STEPS

```
show connection [all | element | id id | name name | port port]
```

The **show connection** command displays the local connection between a Gigabit Ethernet interface and another local Gigabit Ethernet interface:

Example:

```
Router# show connection name ethconn1
Connection: 1 - ethconn1
Current State: UP
Segment 1: GigabitEthernet0/0/0.1 up
Segment 2: GigabitEthernet0/0/0.2 up
```

Verifying the NSF SSO Local Switching Configuration

Layer 2 local switching provides NSF/SSO support for Local Switching of the following attachment circuits on the same router:

- Ethernet/Ethernet VLAN to Ethernet/Ethernet VLAN

For information about configuring NSF/SSO on the Route Processors, see the "Stateful Switchover" module in the *Cisco IOS XE High Availability Configuration Guide*. Perform this task to verify that the NSF/SSO: Layer 2 Local Switching feature is working correctly.

SUMMARY STEPS

1. **ping**
2. **redundancy force-switchover**
3. **show connection all**
4. **ping**

DETAILED STEPS

- Step 1** **ping**
Issue the **ping** command or initiate traffic between the two CE routers.
- Step 2** **redundancy force-switchover**
Force the switchover from the active RP to the standby RP by using the **redundancy force-switchover** command. This manual procedure allows for a "graceful" or controlled shutdown of the active RP and switchover to the standby RP. This graceful shutdown allows critical cleanup to occur.
- Step 3** **show connection all**
Issue the **show connection all** command to ensure that the Layer 2 local switching connection on the dual RP is operating:

Example:

```
Router# show connection all
D   Name                Segment 1                Segment 2                State
-----
1   conn                 Gi0/0/0.1                Gi0/0/0.2                UP
```

- Step 4** **ping**
Issue the **ping** command from the CE router to verify that the contiguous packet outage was minimal during the switchover.

Troubleshooting Tips

You can troubleshoot Layer 2 local switching using the following commands on the PE router:

- **debug conn**
- **show connection**

Configuration Examples for Layer 2 Local Switching

Example: Configuring Ethernet VLAN Same-Port Switching

The following example shows same-port switching between two VLANs on one Ethernet interface:

```
interface fastethernet 0/0.1
 encapsulation dot1q 1
interface fastethernet 0/0.2
 encapsulation dot1q 2
connect conn FastEthernet 0/0.1 FastEthernet 0/0.2
```

Example: Configuring NSF SSO Ethernet Port Mode to Ethernet VLAN Local Switching

The following configuration uses the network topology shown in the figure below.

Figure 2: NSF/SSO: Layer 2 Local Switching: Ethernet to Ethernet VLAN

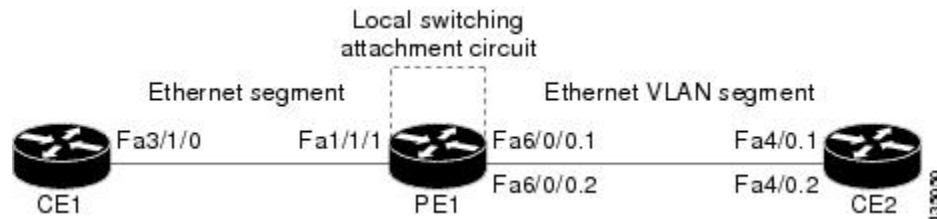

The following example shows the configuration of the CE interfaces to connect to the PE1 router:

CE1	CE2
<pre> ip routing ! interface fa3/1/0 description: connection to PE fa1/1/1 no shutdown ip address 10.1.1.1 255.255.255.0 </pre>	<pre> ip routing ! interface fa4/0 no shutdown ! interface fa4/0.1 description: connection to PE1 fa6/0/0.1 encapsulation dot1Q 10 ip address 10.1.1.2 255.255.255.0 ! interface fa4/0.2 description - connection to PE1 fa6/0/0.2 encapsulation dot1Q 20 ip address 172.16.1.2 255.255.255.0 </pre>

The following example shows the configuration of the PE1 router with NSF/SSO and the PE interfaces to the CE routers:

```

PE1

redundancy
  no keepalive-enable
  mode sso
!
!
ip routing
ip cef distributed
!
interface fa1/1/1
  description - connection to CE1 fa3/1/0
  no shutdown
  no ip address
!
!
interface fa6/0/0
  no shutdown
  no ip address
!
interface fa6/0/0.1
  description - connection to CE2 fa4/0.1
  encapsulation dot1Q 10
  no ip address
!
interface fa6/0/0.2
  description - connection to CE2 fa4/0.2
  encapsulation dot1Q 20
  no ip address

```

Example: Configuring ATM-to-ATM Local Switching

The following example shows local switching on ATM interfaces configured for AAL5:

```

interface atm1/0/0
  pvc 0/100 l2transport
  encapsulation aal5
interface atm2/0/0
  pvc 0/100 l2transport
  encapsulation aal5
connect aal5-conn atm1/0/0 0/100 atm2/0/0 0/100

```

Example: Configuring ATM PVC Same-Port Switching

The following example shows same-port switching between two PVCs on one ATM interface:

```
interface atm1/0/0
 pvc 0/100 l2transport
 encapsulation aal5
 pvc 0/200 l2transport
 encapsulation aal5
 connect conn atm1/0/0 0/100 atm1/0/0 0/200
```

Example: Configuring ATM PVP Same-Port Switching

The following example shows same-port switching between two PVPs on one ATM interface:

```
interface atm1/0/0
 atm pvp 100 l2transport
 atm pvp 200 l2transport
 connect conn atm1/0/0 100 atm1/0/0 200
```

Example: Configuring Frame Relay-to-Frame Relay Local Switching

The following example shows serial interfaces configured for Frame Relay. The **connect** command allows local switching between these two interfaces.

```
frame-relay switching
 ip cef distributed
 interface serial3/0/0
 encapsulation frame-relay
 frame-relay interface-dlci 100 switched
 frame-relay intf-type dce
 interface serial3/1/0
 encapsulation frame-relay ietf
 frame-relay interface-dlci 200 switched
 frame-relay intf-type dce
 connect fr-con serial3/0/0 100 serial3/1/0 200
```

Additional References

Related Documents

Related Topic	Document Title
Cisco IOS commands	Cisco IOS Master Command List, All Releases
WAN Commands	<i>Cisco IOS Wide-Area Networking Command Reference</i>
Stateful switchover configuration information	"Stateful Switchover " module in the <i>Cisco IOS XE High Availability Configuration Guide</i>

Standards

Standard	Title
draft-ietf-l2tpext-l2tp-base-03.txt	<i>Layer Two Tunneling Protocol (Version 3) 'L2TPv3'</i>
draft-martini-l2circuit-trans-mpls-09.txt	<i>Transport of Layer 2 Frames Over MPLS</i>
draft-martini-l2circuit-encap-mpls-04.txt	<i>Encapsulation Methods for Transport of Layer 2 Frames Over IP and MPLS Networks</i>
draft-ietf-ppvpn-l2vpn-00.txt	<i>An Architecture for L2VPNs</i>

MIBs

MIB	MIBs Link
None	To locate and download MIBs for selected platforms, Cisco IOS XE software releases, and feature sets, use Cisco MIB Locator found at the following URL: http://www.cisco.com/go/mibs

RFCs

RFC	Title
None	--

Technical Assistance

Description	Link
The Cisco Support and Documentation website provides online resources to download documentation, software, and tools. Use these resources to install and configure the software and to troubleshoot and resolve technical issues with Cisco products and technologies. Access to most tools on the Cisco Support and Documentation website requires a Cisco.com user ID and password.	http://www.cisco.com/cisco/web/support/index.html

Feature Information for Layer 2 Local Switching

The following table provides release information about the feature or features described in this module. This table lists only the software release that introduced support for a given feature in a given software release train. Unless noted otherwise, subsequent releases of that software release train also support that feature.

Use Cisco Feature Navigator to find information about platform support and Cisco software image support. To access Cisco Feature Navigator, go to www.cisco.com/go/cfn. An account on Cisco.com is not required.

Table 1: Feature Information for Layer 2 Local Switching

Feature Name	Releases	Feature Information
Layer 2 Local Switching	Cisco IOS XE Release 2.5	<p>The Layer 2 Local Switching feature allows you to switch Layer 2 data between two interfaces on the same router, and in some cases to switch Layer 2 data between two circuits on the same interface port.</p> <p>In Cisco IOS XE Release 2.5, this feature was introduced on the Cisco ASR 1000 Series Aggregation Services Routers. Support was added for the following local switching types:</p> <ul style="list-style-type: none"> • Ethernet to Ethernet VLAN • Same-port switching for Ethernet VLAN <p>The following commands were introduced or modified: connect (L2VPN local switching), show connection.</p>
Layer 2 Local Switching - ATM to ATM	Cisco IOS XE Release 3.3S	<p>In Cisco IOS XE Release 3.3S, this feature was introduced on the Cisco ASR 1000 Series Aggregation Services Routers.</p> <p>The following commands were introduced or modified: connect (L2VPN local switching), show connection.</p>
Layer 2 Local Switching - Frame Relay to Frame Relay	Cisco IOS XE Release 3.9S	<p>In Cisco IOS XE Release 3.9S, this feature was introduced on the Cisco ISR 4400 Series Routers.</p>

