



L2VPN VPLS Inter-AS Option B

The L2VPN VPLS Inter-AS Option B feature expands the existing features of VPLS autodiscovery to operate across multiple Border Gateway Protocol (BGP) autonomous systems. Using BGP-based autodiscovery as the underlying framework, the L2VPN VPLS Inter-AS Option B feature creates a dynamic multisegmented pseudowire (PW) configuration between neighboring Autonomous System Boundary Routers (ASBRs.)

- [Finding Feature Information, on page 1](#)
- [Prerequisites for L2VPN VPLS Inter-AS Option B, on page 1](#)
- [Restrictions for L2VPN VPLS Inter-AS Option B, on page 2](#)
- [Information About L2VPN VPLS Inter-AS Option B, on page 2](#)
- [How to Configure L2VPN VPLS Inter-AS Option B, on page 4](#)
- [Configuration Examples for L2VPN VPLS Inter-AS Option B, on page 17](#)
- [Additional References for L2VPN VPLS Inter-AS Option B, on page 31](#)
- [Feature Information for L2VPN VPLS Inter-AS Option B, on page 32](#)
- [Glossary, on page 33](#)

Finding Feature Information

Your software release may not support all the features documented in this module. For the latest caveats and feature information, see [Bug Search Tool](#) and the release notes for your platform and software release. To find information about the features documented in this module, and to see a list of the releases in which each feature is supported, see the feature information table.

Use Cisco Feature Navigator to find information about platform support and Cisco software image support. To access Cisco Feature Navigator, go to www.cisco.com/go/cfn. An account on Cisco.com is not required.

Prerequisites for L2VPN VPLS Inter-AS Option B

The L2VPN VPLS Inter-AS Option B feature extends the functionality of the VPLS Autodiscovery: BGP Based feature. For example, as a result of L2VPN VPLS Inter-AS Option B feature, stateful switchover (SSO) and nonstop forwarding (NSF) are supported in a standard VPLS Autodiscovery configuration.

Before you configure the L2VPN VPLS Inter-AS Option B feature, enable the VPLS Autodiscovery: BGP Based feature and complete the steps described in the [Modifying the VPLS Autodiscovery Settings for Use with L2VPN VPLS Inter-AS Option B, on page 4](#).

For more information about the VPLS Autodiscovery: BGP Based feature, see the “VPLS Autodiscovery: BGP” module.

Restrictions for L2VPN VPLS Inter-AS Option B

Introduced in Cisco IOS Release 15.1(1)S, the L2VPN VPLS Inter-AS Option B feature is supported only on a Cisco 7600 series router that is equipped with a line card capable of running Virtual Private LAN Switching (VPLS).

Information About L2VPN VPLS Inter-AS Option B

VPLS Functionality and L2VPN VPLS Inter-AS Option B

VPLS is a multipoint Layer 2 VPN (L2VPN) that connects two or more customer devices using Ethernet over Multiprotocol Label Switching (EoMPLS) bridging techniques.

VPLS Inter-AS support exists in a number of variations or options (for example, Option A, B, C, and D). The L2VPN VPLS Inter-AS Option B feature supports Option B only and is in compliance with [RFC 4364](#), BGP/MPLS IP Virtual Private Networks (VPNs) .

For more information about VPLS, see the “[VPLS Overview](#)” section in the [Configuring Multiprotocol Label Switching on the Optical Services Modules](#) document.

L2VPN VPLS Inter-AS Option B Description

The L2VPN VPLS Inter-AS Option B feature extends VPLS across multiple autonomous system boundaries by dynamically creating multisegment pseudowires across the ASBRs.

When a router with external BGP (eBGP) advertises routes to its BGP neighbors, the router uses the source IP address as the next hop of the advertised routes.

When a router with internal BGP (iBGP) advertises routes to its BGP neighbors, the router does not change the next hop designation of the route advertised. For the L2VPN VPLS Inter-AS Option B feature, enter the **neighbor next-hop-self** command at the ASBRs. This forces the pseudowires to be targeted to the ASBR and not targeted to the provider edge (PE) routers. The net result is that a pseudowire for the first autonomous system is stitched to a pseudowire for the second autonomous system by means of a third pseudowire between the ASBRs. This creates a multisegmented pseudowire. For more information about multisegmented pseudowires, see the “L2VPN Multisegment Pseudowires” module.



Note The L2VPN VPLS Inter-AS Option B feature supports Route Processors (RPs), SSO, and NSF.

L2VPN VPLS Inter-AS Option B Sample Topology

The figure below illustrates a simplified L2VPN VPLS Inter-AS Option B topology. In this topology, AS1 and AS2 are the autonomous systems. ASBR1 and ASBR2 are ASBRs. A customer edge (CE) router is attached to both AS1 and AS2.

Each autonomous system consists of an ASBR and a PE router. PE1 belongs to a virtual forwarding instance (VFI) in AS1. PE2 belongs to a VFI in AS2. PE1 and PE2 are terminating PEs (TPEs).

Multisegmented pseudowires are created to establish dual connections between the TPE in the local ASBR to the TPE in the neighboring ASBR. The first segment establishes a path between the TPE in AS1 to ASBR1. The next segment establishes a path between the ASBR1 and ASBR2, and the final segment establishes a path between ASBR2 to the TPE in AS2.

Figure 1: Sample L2VPN VPLS Inter-AS Option B Topology

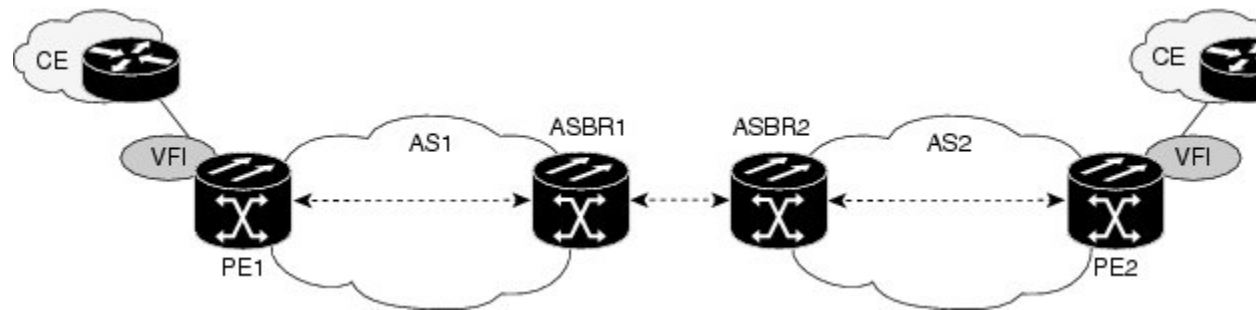

Active and Passive PEs in an L2VPN VPLS Inter-AS Option B Configuration

A TPE terminates a multisegment pseudowire. By default, the TPEs on both ends of a multisegmented pseudowire are in active mode. The L2VPN VPLS Inter-AS Option B feature requires that one of the TPEs be in passive mode. The system determines which PE is the passive TPE based on a comparison of the Target Attachment Individual Identifier (TAII) received from BGP and the Source Attachment Individual Identifier (SAII) of the local router. The TPE with the numerically higher identifier assumes the active role.

When you are configuring the PEs for the L2VPN VPLS Inter-AS Option B feature, use the **terminating-pe tie-breaker** command to negotiate the mode of the TPE. Then use the **mpls ldp discovery targeted-hello accept** command to ensure that a passive TPE can accept Label Distribution Protocol (LDP) sessions from the LDP peers.

For more information about configuring the PEs, see the [Enabling L2VPN VPLS Inter-AS Option B on the Provider Edge \(PE\) Router](#), on page 13.

Benefits of L2VPN VPLS Inter-AS Option B

Private IP Addresses

While a large number of pseudowires are required, IPv4 reachability is maintained within the ASBR and, therefore, IP addresses are private.

One Targeted LDP Session

With the L2VPN VPLS Inter-AS Option B feature, only one targeted Label Distribution Protocol (LDP) session is created between the autonomous systems. Since only one targeted LDP session between autonomous systems is created, service providers can apply tighter security policies for control plane traffic going across the autonomous system.

How to Configure L2VPN VPLS Inter-AS Option B

Modifying the VPLS Autodiscovery Settings for Use with L2VPN VPLS Inter-AS Option B



Note Before you configure the L2VPN VPLS Inter-AS Option B feature, you must enable the VPLS Autodiscovery: BGP Based feature. Make sure you have enabled the VPLS Autodiscovery: BGP Based feature before proceeding with this task.

For the L2VPN VPLS Inter-AS Option B feature to function properly, you must configure the VPLS ID value and the route-target value for each PE router in the virtual forwarding instance (VFI). To modify these values, complete the following steps at each PE router.

SUMMARY STEPS

1. **enable**
2. **configure terminal**
3. **l2 vfi *vfi-name* autodiscovery**
4. **vpn id *vpn-id***
5. **vpls-id {*autonomous-system-number* : *nn* | *ip-address* : *nn*}**
6. **route-target [*import* | *export* | *both*] {*autonomous-system-number* : *nn* | *ip-address* : *nn*}**
7. **exit**

DETAILED STEPS

	Command or Action	Purpose
Step 1	enable Example: Router> enable	Enables privileged EXEC mode. <ul style="list-style-type: none"> • Enter your password if prompted.
Step 2	configure terminal Example: Router# configure terminal	Enters global configuration mode.
Step 3	l2 vfi <i>vfi-name</i> autodiscovery Example: Router(config)# l2 vfi vpls1 autodiscovery	Enables the VPLS Autodiscovery: BGP Based feature on the PE router and enters L2 VFI configuration mode.
Step 4	vpn id <i>vpn-id</i> Example:	Configures a VPN ID for the VPLS domain. <ul style="list-style-type: none"> • Enter a VPN ID value.

	Command or Action	Purpose
	Router(config-vfi)# vpn id 10	
Step 5	<p>vpls-id {<i>autonomous-system-number</i> : <i>nn</i> <i>ip-address</i> : <i>nn</i>}</p> <p>Example:</p> <pre>Router(config-vfi)# vpls-id 5:300</pre>	<p>Specifies the VPLS ID.</p> <ul style="list-style-type: none"> The VPLS Autodiscovery: BGP Based feature automatically generates a VPLS ID using the BGP autonomous system number and the configured VFI VPN ID. Use this command to change the automatically generated VPLS ID for the PE in the VFI. There are two formats for configuring the VPLS ID argument. It can be configured in the <i>autonomous-system-number</i> : <i>network number</i> (ASN : <i>nn</i>) format, as shown in the example, or it can be configured in the <i>IP-address</i>:<i>network number</i> format (<i>IP-address</i> : <i>nn</i>).
Step 6	<p>route-target [import export both] {<i>autonomous-system-number</i> : <i>nn</i> <i>ip-address</i> : <i>nn</i>}</p> <p>Example:</p> <pre>Router(config-vfi)# route-target 600:2222</pre>	<p>Specifies the route target (RT).</p> <ul style="list-style-type: none"> The VPLS Autodiscovery feature automatically generates a route target using the lower 6 bytes of the RD and VPN ID. Use this command to change the automatically generated route target for the PE in the VFI. There are two formats for configuring the route target argument. It can be configured in the <i>autonomous-system-number</i> : <i>network number</i> (ASN : <i>nn</i>) format, as shown in the example, or it can be configured in the <i>IP-address</i>:<i>network number</i> format (<i>IP-address</i> : <i>nn</i>).
Step 7	<p>exit</p> <p>Example:</p> <pre>Router(config-vfi)# exit</pre>	<p>Exits L2 VFI configuration mode.</p> <ul style="list-style-type: none"> Commands take effect after the router exits L2 VFI configuration mode.

What to Do Next

Repeat the steps in the [Modifying the VPLS Autodiscovery Settings for Use with L2VPN VPLS Inter-AS Option B, on page 4](#) at each PE in the autonomous system. Then proceed to the [Enabling L2VPN VPLS Inter-AS Option B on the ASBR, on page 8](#).

Modifying the VPLS Autodiscovery Settings for Use with L2VPN VPLS Inter-AS Option B using the commands associated with the L2VPN Protocol-Based CLIs feature



Note Before you configure the L2VPN VPLS Inter-AS Option B feature, you must enable the VPLS Autodiscovery: BGP Based feature. Make sure you have enabled the VPLS Autodiscovery: BGP Based feature before proceeding with this task.

For the L2VPN VPLS Inter-AS Option B feature to function properly, you must configure the VPLS ID value and the route-target value for each PE router in the virtual forwarding instance (VFI). To modify these values, complete the following steps at each PE router.

SUMMARY STEPS

1. **enable**
2. **configure terminal**
3. **l2vpn vfi context** *vfi-name*
4. **vpn id** *vpn-id*
5. **autodiscovery bgp signaling ldp**
6. **vpls-id** {*autonomous-system-number : nn* | *ip-address : nn*}
7. **route-target** [**import** | **export** | **both**] {*autonomous-system-number : nn* | *ip-address : nn*}
8. **exit**

DETAILED STEPS

	Command or Action	Purpose
Step 1	enable Example: Device> enable	Enables privileged EXEC mode. <ul style="list-style-type: none"> • Enter your password if prompted.
Step 2	configure terminal Example: Device# configure terminal	Enters global configuration mode.
Step 3	l2vpn vfi context <i>vfi-name</i> Example: Device(config)# l2vpn vfi context vpls1	Establishes an L2VPN VFI context and enters L2 VFI configuration mode.
Step 4	vpn id <i>vpn-id</i> Example: Device(config-vfi)# vpn id 10	Configures a VPN ID for the VPLS domain. <ul style="list-style-type: none"> • Enter a VPN ID value.

	Command or Action	Purpose
Step 5	<p>autodiscovery bgp signaling ldp</p> <p>Example:</p> <pre>Device(config-vfi)# autodiscovery bgp signaling ldp</pre>	Enables the VPLS Autodiscovery: BGP Based feature on the PE router.
Step 6	<p>vpls-id {<i>autonomous-system-number : nn</i> <i>ip-address : nn</i>}</p> <p>Example:</p> <pre>Device(config-vfi)# vpls-id 5:300</pre>	<p>Specifies the VPLS ID.</p> <ul style="list-style-type: none"> The VPLS Autodiscovery: BGP Based feature automatically generates a VPLS ID using the BGP autonomous system number and the configured VFI VPN ID. Use this command to change the automatically generated VPLS ID for the PE in the VFI. There are two formats for configuring the VPLS ID argument. It can be configured in the <i>autonomous-system-number : network number (ASN : nn)</i> format, as shown in the example, or it can be configured in the <i>IP-address:network number (IP-address : nn)</i>.
Step 7	<p>route-target [import export both] {<i>autonomous-system-number : nn</i> <i>ip-address : nn</i>}</p> <p>Example:</p> <pre>Device(config-vfi)# route-target 600:2222</pre>	<p>Specifies the route target (RT).</p> <ul style="list-style-type: none"> The VPLS Autodiscovery feature automatically generates a route target using the lower 6 bytes of the RD and VPN ID. Use this command to change the automatically generated route target for the PE in the VFI. There are two formats for configuring the route target argument. It can be configured in the <i>autonomous-system-number : network number (ASN : nn)</i> format, as shown in the example, or it can be configured in the <i>IP-address:network number (IP-address : nn)</i>.
Step 8	<p>exit</p> <p>Example:</p> <pre>Device(config-vfi)# exit</pre>	<p>Exits L2 VFI configuration mode.</p> <ul style="list-style-type: none"> Commands take effect after the router exits L2 VFI configuration mode.

What to Do Next

Repeat the steps in the [Modifying the VPLS Autodiscovery Settings for Use with L2VPN VPLS Inter-AS Option B, on page 4](#) at each PE in the autonomous system. Then proceed to the [Enabling L2VPN VPLS Inter-AS Option B on the ASBR, on page 8](#).

Enabling L2VPN VPLS Inter-AS Option B on the ASBR

To enable the L2VPN VPLS Inter-AS Option B feature on the ASBR, complete the following steps on *each* ASBR in the autonomous system.

SUMMARY STEPS

1. **enable**
2. **configure terminal**
3. **router bgp** *autonomous-system-number*
4. **neighbor** *{ip-address | peer-group-name}* **next-hop-self**
5. **address-family l2vpn vpls**
6. **no bgp default route-target filter**
7. **exit**
8. **exit**
9. **mpls ldp discovery targeted-hello accept**
10. Complete Steps 11 through 13, only if you are changing the range of VC IDs reserved for switching pseudowires. Otherwise, advance to Step 14.
11. **l2 pseudowire routing**
12. **switching-point vcid** *minimum-vcid-value maximum-vcid-value*
13. **exit**
14. **end**

DETAILED STEPS

	Command or Action	Purpose
Step 1	enable Example: Router> enable	Enables privileged EXEC mode. <ul style="list-style-type: none"> • Enter your password if prompted.
Step 2	configure terminal Example: Router# configure terminal	Enters global configuration mode.
Step 3	router bgp <i>autonomous-system-number</i> Example: Router(config)# router bgp 1	Configures the BGP routing process and enters router configuration mode. <ul style="list-style-type: none"> • Enter the number of the autonomous system.
Step 4	neighbor <i>{ip-address peer-group-name}</i> next-hop-self Example: Router(config-router)# neighbor 10.10.0.1 next-hop-self	Configures the ASBR as the next hop for a BGP-speaking neighbor or peer group. <ul style="list-style-type: none"> • Enter the IP address or the peer group name. <p>Note Use this command to identify each PE in the autonomous system.</p>

	Command or Action	Purpose
Step 5	address-family l2vpn vpls Example: <pre>Router(config-router)# address-family l2vpn vpls</pre>	Configures a routing session using L2VPN endpoint provisioning address information and enters address family configuration mode.
Step 6	no bgp default route-target filter Example: <pre>Router(config-router-af)# no bgp default route-target filter</pre>	Enables pseudowire switching at the ASBR.
Step 7	exit Example: <pre>Router(config-router-af) exit</pre>	Exits address family configuration mode.
Step 8	exit Example: <pre>Router(config-router) exit</pre>	Exits router configuration mode.
Step 9	mpls ldp discovery targeted-hello accept Example: <pre>Router(config)# mpls ldp discovery targeted-hello accept</pre>	Configures the routers from which LDP sessions will be accepted. <ul style="list-style-type: none"> • With the targeted-hello accept keywords, LDP sessions from <i>any</i> router will be accepted. • For the other keyword choices available for this command, see the <i>Cisco IOS Multiprotocol Label Switching Command Reference</i>.
Step 10	Complete Steps 11 through 13, only if you are changing the range of VC IDs reserved for switching pseudowires. Otherwise, advance to Step 14.	
Step 11	l2 pseudowire routing Example: <pre>Router(config)# l2 pseudowire routing</pre>	(Optional) Enters Layer 2 pseudowire routing configuration mode.
Step 12	switching-point vcid <i>minimum-vcid-value</i> <i>maximum-vcid-value</i> Example: <pre>Router(config-l2_pw_rtg)# switching-point vcid 200 3500</pre>	(Optional) Configures a switching point and specifies a virtual circuit (VC) ID range. Note With the L2VPN VPLS Inter-AS Option B feature, VC IDs in the VC ID range of 1001 to 2147483647 are reserved for switching pseudowires. This command allows you to change this range if, for example, an existing xconnect VC is using one of the reserved VC IDs.

	Command or Action	Purpose
Step 13	exit Example: <pre>Router(config-l2_pw_rtg)# exit</pre>	Exits Layer 2 pseudowire routing configuration mode.
Step 14	end Example: <pre>Router(config)# end</pre>	Exits global configuration mode.

What to Do Next

Repeat the steps in the [Enabling L2VPN VPLS Inter-AS Option B on the ASBR, on page 8](#) at each ASBR in the autonomous system. Then proceed to the [Enabling L2VPN VPLS Inter-AS Option B on the Provider Edge \(PE\) Router, on page 13](#).

Enabling L2VPN VPLS Inter-AS Option B on the ASBR using the commands associated with the L2VPN Protocol-Based CLIs feature

To enable the layer 2 virtual private network virtual private LAN services (L2VPN VPLS) Inter-AS Option B feature on the autonomous system boundary router (ASBR), perform this task on each ASBR in the autonomous system.

SUMMARY STEPS

1. **enable**
2. **configure terminal**
3. **router bgp *autonomous-system-number***
4. **neighbor {*ip-address* | *peer-group-name*} next-hop-self**
5. **address-family l2vpn vpls**
6. **no bgp default route-target filter**
7. **exit**
8. **exit**
9. **mpls ldp discovery targeted-hello accept**
10. Complete Steps 11 through 13, only if you are changing the range of VC IDs reserved for switching pseudowires. Otherwise, advance to Step 14.
11. **l2vpn**
12. **pseudowire routing**
13. **switching-point vcid *minimum-vcid-value* *maximum-vcid-value***
14. **exit**
15. **end**

DETAILED STEPS

	Command or Action	Purpose
Step 1	enable Example: Device> enable	Enables privileged EXEC mode. <ul style="list-style-type: none">• Enter your password if prompted.
Step 2	configure terminal Example: Device# configure terminal	Enters global configuration mode.
Step 3	router bgp <i>autonomous-system-number</i> Example: Device(config)# router bgp 1	Configures the BGP routing process and enters router configuration mode. <ul style="list-style-type: none">• Enter the number of the autonomous system.
Step 4	neighbor {<i>ip-address</i> <i>peer-group-name</i>} next-hop-self Example: Device(config-router)# neighbor 10.10.0.1 next-hop-self	Configures the ASBR as the next hop for a BGP-speaking neighbor or peer group. <ul style="list-style-type: none">• Enter the IP address or the peer group name. Note Use this command to identify each PE in the autonomous system.
Step 5	address-family l2vpn vpls Example: Device(config-router)# address-family l2vpn vpls	Configures a routing session using L2VPN endpoint provisioning address information and enters address family configuration mode.
Step 6	no bgp default route-target filter Example: Device(config-router-af)# no bgp default route-target filter	Enables pseudowire switching at the ASBR.
Step 7	exit Example: Device(config-router-af) exit	Exits address family configuration mode.
Step 8	exit Example: Device(config-router) exit	Exits router configuration mode.
Step 9	mpls ldp discovery targeted-hello accept Example:	Configures the routers from which LDP sessions will be accepted.

	Command or Action	Purpose
	<pre>Device(config)# mpls ldp discovery targeted-hello accept</pre>	<ul style="list-style-type: none"> • With the targeted-hello accept keywords, LDP sessions from <i>any</i> router will be accepted. • For the other keyword choices available for this command, see the <i>Cisco IOS Multiprotocol Label Switching Command Reference</i>.
Step 10	Complete Steps 11 through 13, only if you are changing the range of VC IDs reserved for switching pseudowires. Otherwise, advance to Step 14.	
Step 11	<p>l2vpn</p> <p>Example:</p> <pre>Device(config)# l2vpn</pre>	(Optional) Enters Layer 2 VPN configuration mode.
Step 12	<p>pseudowire routing</p> <p>Example:</p> <pre>Device(l2vpn-config)# pseudowire routing</pre>	(Optional) Enters Layer 2 pseudowire routing configuration mode.
Step 13	<p>switching-point vcid <i>minimum-vcid-value</i> <i>maximum-vcid-value</i></p> <p>Example:</p> <pre>Device(config-l2_pw_rtg)# switching-point vcid 200 3500</pre>	<p>(Optional) Configures a switching point and specifies a virtual circuit (VC) ID range.</p> <p>Note With the L2VPN VPLS Inter-AS Option B feature, VC IDs in the VC ID range of 1001 to 2147483647 are reserved for switching pseudowires. This command allows you to change this range if, for example, an existing xconnect VC is using one of the reserved VC IDs.</p>
Step 14	<p>exit</p> <p>Example:</p> <pre>Device(config-l2_pw_rtg)# exit</pre>	Exits Layer 2 pseudowire routing configuration mode.
Step 15	<p>end</p> <p>Example:</p> <pre>Device(config)# end</pre>	Exits global configuration mode.

What to Do Next

Repeat the steps in the [Enabling L2VPN VPLS Inter-AS Option B on the ASBR, on page 8](#) at each ASBR in the autonomous system. Then proceed to the [Enabling L2VPN VPLS Inter-AS Option B on the Provider Edge \(PE\) Router, on page 13](#).

Enabling L2VPN VPLS Inter-AS Option B on the Provider Edge (PE) Router

To enable the L2VPN VPLS Inter-AS Option B on the PE router, complete the following steps on each PE in the autonomous system.

SUMMARY STEPS

1. **enable**
2. **configure terminal**
3. **l2 pseudowire routing**
4. **terminating-pe tie-breaker**
5. **exit**
6. **mpls ldp discovery targeted-hello accept**
7. **end**

DETAILED STEPS

	Command or Action	Purpose
Step 1	enable Example: <pre>Router> enable</pre>	Enables privileged EXEC mode. <ul style="list-style-type: none"> • Enter your password if prompted.
Step 2	configure terminal Example: <pre>Router# configure terminal</pre>	Enters global configuration mode.
Step 3	l2 pseudowire routing Example: <pre>Router(config)# l2 pseudowire routing</pre>	Enters Layer 2 pseudowire routing configuration mode.
Step 4	terminating-pe tie-breaker Example: <pre>Router(config-l2_pw_rtg)# terminating-pe tie-breaker</pre>	Negotiates the behavior mode (either active or passive) for a terminating provider edge (TPE) route.
Step 5	exit Example: <pre>Router(config-l2_pw_rtg)# exit</pre>	Returns to global configuration mode.
Step 6	mpls ldp discovery targeted-hello accept Example: <pre>Router(config)# mpls ldp discovery targeted-hello accept</pre>	Configures the routers from which LDP sessions will be accepted. <ul style="list-style-type: none"> • With the targeted-hello accept keywords, LDP sessions from <i>any</i> router will be accepted.

	Command or Action	Purpose
		<ul style="list-style-type: none"> For the other keyword choices available for this command, see the <i>Cisco IOS Multiprotocol Label Switching Command Reference</i>.
Step 7	end Example: Router(config)# end	Exits global configuration mode.

What to Do Next

Repeat the steps in the [Enabling L2VPN VPLS Inter-AS Option B on the Provider Edge \(PE\) Router, on page 13](#) at each PE in the autonomous system. Then proceed to the [Verifying the L2VPN VPLS Inter-AS Option B Configuration, on page 15](#).

Enabling L2VPN VPLS Inter-AS Option B on the Provider Edge (PE) Router using the commands associated with the L2VPN Protocol-Based CLIs feature

To enable the L2VPN VPLS Inter-AS Option B on the PE router, perform this task on each PE in the autonomous system.

SUMMARY STEPS

1. enable
2. configure terminal
3. l2vpn
4. pseudowire routing
5. terminating-pe tie-breaker
6. end
7. mpls ldp discovery targeted-hello accept
8. end

DETAILED STEPS

	Command or Action	Purpose
Step 1	enable Example: Device> enable	Enables privileged EXEC mode. <ul style="list-style-type: none"> Enter your password if prompted.
Step 2	configure terminal Example: Device# configure terminal	Enters global configuration mode.

	Command or Action	Purpose
Step 3	l2vpn Example: Device(config)# l2vpn	(Optional) Enters Layer 2 VPN configuration mode.
Step 4	pseudowire routing Example: Device(l2vpn-config)# pseudowire routing	(Optional) Enters Layer 2 pseudowire routing configuration mode.
Step 5	terminating-pe tie-breaker Example: Device(config-l2_pw_rtg)# terminating-pe tie-breaker	Negotiates the behavior mode (either active or passive) for a terminating provider edge (TPE) route.
Step 6	end Example: Device(config-l2_pw_rtg)# exit	Returns to global configuration mode.
Step 7	mpls ldp discovery targeted-hello accept Example: Device(config)# mpls ldp discovery targeted-hello accept	Configures the routers from which LDP sessions will be accepted. <ul style="list-style-type: none"> • With the targeted-hello accept keywords, LDP sessions from <i>any</i> router will be accepted. • For the other keyword choices available for this command, see the <i>Cisco IOS Multiprotocol Label Switching Command Reference</i>.
Step 8	end Example: Device(config)# end	Exits global configuration mode.

What to Do Next

Repeat the steps in the [Enabling L2VPN VPLS Inter-AS Option B on the Provider Edge \(PE\) Router, on page 13](#) at each PE in the autonomous system. Then proceed to the [Verifying the L2VPN VPLS Inter-AS Option B Configuration, on page 15](#).

Verifying the L2VPN VPLS Inter-AS Option B Configuration

To verify the L2VPN VPLS Inter-AS Option B configuration, use one or more of the following commands at any router.

SUMMARY STEPS

1. `enable`
2. `show xconnect rib detail`
3. `show mpls l2transport vc [detail] [pwid pw-identifier] [vpls-id vpls-identifier] [stitch endpoint endpoint]`
4. `end`

DETAILED STEPS

	Command or Action	Purpose
Step 1	enable Example: Router> enable	Enables privileged EXEC mode. <ul style="list-style-type: none"> • Enter your password if prompted.
Step 2	show xconnect rib detail Example: Router# show xconnect rib detail	(Optional) Displays the information about the pseudowire Routing Information Base (RIB).
Step 3	show mpls l2transport vc [detail] [pwid pw-identifier] [vpls-id vpls-identifier] [stitch endpoint endpoint] Example: Router# show mpls l2transport vc	(Optional) Displays the information about Multiprotocol Label Switching (MPLS) Any Transport over ATM (AToM) VCs and static pseudowires that have been enabled to route Layer 2 packets on a router. <ul style="list-style-type: none"> • Use the optional keywords and arguments, as applicable.
Step 4	end Example: Router# end	Exits privileged EXEC mode.

Verifying the L2VPN VPLS Inter-AS Option B Configuration using the commands associated with the L2VPN Protocol-Based CLIs feature

To verify the L2VPN VPLS Inter-AS Option B configuration, use one or more of the following commands on any router.

SUMMARY STEPS

1. `enable`
2. `show l2vpn rib detail`
3. `show l2vpn atom vc [pwid pw-identifier] [vpls-id vpls-identifier] [stitch endpoint endpoint][detail]`
4. `end`

DETAILED STEPS

	Command or Action	Purpose
Step 1	enable Example: Device> enable	Enables privileged EXEC mode. <ul style="list-style-type: none"> • Enter your password if prompted.
Step 2	show l2vpn rib detail Example: Device# show l2vpn rib detail	(Optional) Displays the information about the pseudowire Routing Information Base (RIB).
Step 3	show l2vpn atom vc [pwid pw-identifier] [vpls-id vpls-identifier] [stitch endpoint endpoint][detail] Example: Device# show l2vpn atom vc	(Optional) Displays the information about Multiprotocol Label Switching (MPLS) Any Transport over ATM (AToM) VCs and static pseudowires that have been enabled to route Layer 2 packets on a router. <ul style="list-style-type: none"> • Use the optional keywords and arguments, as applicable.
Step 4	end Example: Device# end	Exits privileged EXEC mode.

Configuration Examples for L2VPN VPLS Inter-AS Option B

Example Modifying the VPLS Autodiscovery Settings for Use with L2VPN VPLS Inter-AS Option B

In the following example, the VPLS Autodiscovery: BGP Based feature is modified for use with the L2VPN VPLS Inter-AS Option B feature:

```

Router> enable

Router# configure terminal

Router(config)# l2 vfi vpls1 autodiscovery

Router(config-vfi)# vpn id 10

Router(config-vfi)# vpls-id 5:300

Router(config-vfi)# route-target 600:2222

```

```
Router(config-vfi)# exit
```

Example: Modifying the VPLS Autodiscovery Settings for Use with L2VPN VPLS Inter-AS Option B using the commands associated with the L2VPN Protocol-Based CLIs feature

In the following example, the VPLS Autodiscovery: BGP Based feature is modified for use with the L2VPN VPLS Inter-AS Option B feature:

```
Device# enable
Device# configure terminal
Device(config)# l2vpn vfi context vpls1
Device(config-vfi)# vpn id id
Device(config-vfi)# autodiscovery bgp signaling ldp
Device(config-vfi)# vpls-id 5:300
Device(config-vfi)# route-target 600:2222
Device(config-vfi)# exit
```

Example Enabling L2VPN VPLS Inter-AS Option B on the ASBR

In the following example, the L2VPN VPLS Inter-AS Option B feature has been configured on one ASBR:

```
Router> enable

Router# configure terminal

Router(config)# router bgp 1

Router(config-router)# neighbor 10.10.0.1 next-hop-self

Router(config-router)# address-family l2vpn vpls

Router(config-router-af)# no bgp default route-target filter

Router(config-router-af)# exit

Router(config-router)# exit

Router(config)# mpls ldp discovery targeted-hello accept

Router(config)# end
```

Example Enabling L2VPN VPLS Inter-AS Option B on the PE Router

In the following example, the L2VPN VPLS Inter-AS Option B feature is configured on a PE router. The PE is also a TPE.

```
Router> enable

Router# configure terminal

Router(config)# l2 pseudowire routing

Router(config-l2_pw_rtg)# terminating-pe tie-breaker

Router(config-l2_pw_rtg)# exit

Router(config)# mpls ldp discovery targeted-hello accept

Router(config)# end
```

Example Enabling L2VPN VPLS Inter-AS Option B on the PE Device using the commands associated with the L2VPN Protocol-Based CLIs feature

In the following example, the L2VPN VPLS Inter-AS Option B feature is configured on a provider edge (PE) router. The PE is also a terminating provider edge (TPE).

```
Device> enable
Device# configure terminal
Device(config)# l2vpn
Device(l2vpn-config)# pseudowire routing
Device(config-l2_pw_rtg)# terminating-pe tie-breaker
Device(config-l2_pw_rtg)# exit
Device(config)# mpls ldp discovery targeted-hello accept
Device(config)# end
```

Example Verifying the L2VPN VPLS Inter-AS Option B Configuration

The output of the **show xconnect rib detail** command can be used to verify the L2VPN VPLS Inter-AS Option B configuration.

The following is sample output from the **show xconnect rib detail** command when used in an ASBR configuration. On an ASBR, the **show xconnect rib detail** command displays the Layer 2 VPN BGP Network Layer Reachability Information (NLRI) received from the BGP peers. The display also shows the signaling messages received from the targeted LDP sessions for a given TAIL.

```
Router# show xconnect rib detail
Local Router ID: 10.1.1.3
VPLS-ID: 1:1, Target ID: 10.1.1.1
  Next-Hop: 10.1.1.1
  Hello-Source: 10.1.1.3
  Route-Target: 2:2
```

```

Incoming RD: 10.0.0.0:1
Forwarder:
Origin: BGP
Provisioned: Yes
SAII: 10.0.0.1, LDP Peer Id: 10.255.255.255, VC Id: 1001 ***
SAII: 10.1.0.1, LDP Peer Id: 10.255.255.255, VC Id: 1002 ***

```

After the passive TPE router receives the BGP information (and before the passive TPE router receives the LDP label), the peer information will be displayed in the output of the **show xconnect rib** command. The peer information will not be displayed in the **show mpls l2transport vc** command because the VFI AToM xconnect has not yet been provisioned.

Therefore, for passive TPEs, the entry “Passive : Yes” is added to the output of the **show xconnect rib detail** command. In addition, the entry “Provisioned: Yes” is displayed after the neighbor xconnect is successfully created (without any retry attempts).

In the sample output, the two lines beginning with “SAII” show that this ASBR is stitching two provider PE routers (10.0.0.1 and 10.1.0.1) to the TAIL 10.1.1.1.

Example Verifying the L2VPN VPLS Inter-AS Option B Configuration using the commands associated with the L2VPN Protocol-Based CLIs feature

The output of the **show l2vpn rib detail** command can be used to verify the L2VPN VPLS Inter-AS Option B configuration.

The following is sample output from the **show l2vpn rib detail** command when used in an autonomous system boundary router (ASBR) configuration. On an ASBR, the **show l2vpn rib detail** command displays the Layer 2 VPN BGP Network Layer Reachability Information (NLRI) received from the BGP peers. The display also shows the signaling messages received from the targeted label distribution protocol (LDP) sessions for a given TAIL.

```

Device# show l2vpn rib detail
Local Router ID: 10.1.1.3
VPLS-ID: 1:1, Target ID: 10.1.1.1
Next-Hop: 10.1.1.1
Hello-Source: 10.1.1.3
Route-Target: 2:2
Incoming RD: 10.0.0.0:1
Forwarder:
Origin: BGP
Provisioned: Yes
SAII: 10.0.0.1, LDP Peer Id: 10.255.255.255, VC Id: 1001 ***
SAII: 10.1.0.1, LDP Peer Id: 10.255.255.255, VC Id: 1002 ***

```

After the passive terminating provider edge (TPE) router receives the BGP information (and before the passive TPE router receives the LDP label), the peer information will be displayed in the output of the **show l2vpn rib** command. The peer information will not be displayed in the **show l2vpn atom vc** command because the VFI AToM xconnect has not yet been provisioned.

Therefore, for passive TPEs, the entry “Passive : Yes” is added to the output of the **show l2vpn rib detail** command. In addition, the entry “Provisioned: Yes” is displayed after the neighbor xconnect is successfully created (without any retry attempts).

In the sample output, the two lines beginning with “SAII” show that this ASBR is stitching two provider PE routers (10.0.0.1 and 10.1.0.1) to the TAIL 10.1.1.1.

Example Sample L2VPN VPLS Inter-AS Option B Configuration

The following is a sample L2VPN VPLS Inter-AS Option B configuration based on the topology shown in the figure below.

Figure 2: L2VPN VPLS Inter-AS Option B Topology Used for Configuration Example

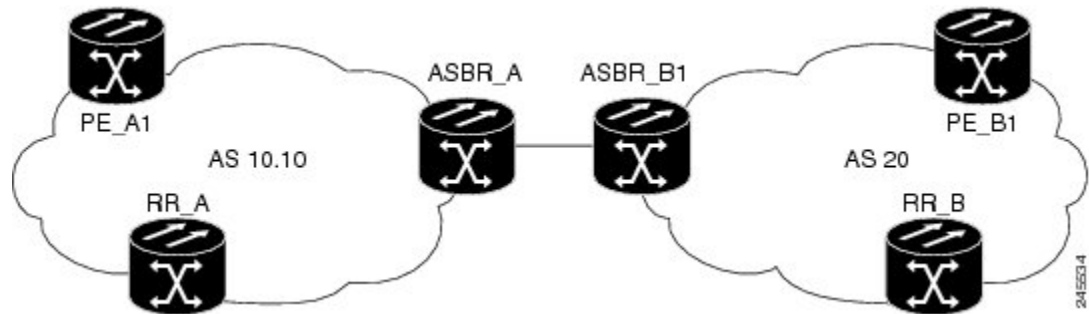

The topology shown in the figure above consists of two PE routers connected across an autonomous system boundary using two ASBRs. Routes are shared within each autonomous system using BGP route reflectors (RRs). (The RRs are included only for the purpose of showing a complete configuration. RRs are not a requirement for the L2VPN Inter-AS Option B configuration.)

The specific configurations for each of the elements in this topology are shown below. The text in bold indicates the additions needed to the standard VPLS Autodiscovery: BGP Based configuration.

PE_A1 Router

```

mpls ldp discovery targeted-hello accept
mpls label protocol ldp
!
!
l2 router-id 10.1.1.1
!
l2 pseudowire routing
  terminating-pe tie-breaker
!
l2 vfi vfiA autodiscovery
  vpn id 111
  vpls-id 111:111
  rd 111:111
  route-target 111:111
  no auto-route-target
!
!
interface Loopback0
  ip address 10.1.1.1 255.255.255.255
!
!
interface GigabitEthernet2/0/9
  description AS-10.10-Backbone-LAN
  ip address 10.100.100.1 255.255.255.0
  mpls ip
!
router ospf 10
  network 10.1.1.1 0.0.0.0 area 0
  network 10.100.100.1 0.0.0.0 area 0
!
router bgp 10.10

```

```

bgp asnotation dot
bgp log-neighbor-changes
no bgp default ipv4-unicast
neighbor 10.3.3.3 remote-as 10.10
neighbor 10.3.3.3 description RR-AS-10.10
neighbor 10.3.3.3 update-source Loopback0
!
address-family ipv4
no auto-summary
exit-address-family
!
address-family l2vpn vpls
neighbor 10.3.3.3 activate
neighbor 10.3.3.3 send-community extended
exit-address-family
!
mpls ldp router-id Loopback0
!

```

ASBR_A Router

```

mpls ldp discovery targeted-hello accept
mpls label protocol ldp
!
!
interface Loopback0
ip address 10.4.4.4 255.255.255.255
!
interface GigabitEthernet1/10
description AS-10.10-backbone-Lan
ip address 10.100.100.4 255.255.255.0
mpls ip
!
interface GigabitEthernet2/0/1
description B2B-AS-20-ASBR-B1
ip address 10.12.1.4 255.255.255.0
mpls ip
!
router ospf 10
passive-interface GigabitEthernet1/12
passive-interface GigabitEthernet2/0/1
passive-interface GigabitEthernet2/0/2
network 10.4.4.4 0.0.0.0 area 0
network 10.100.100.4 0.0.0.0 area 0
network 10.12.0.0 0.0.255.255 area 0
!
router bgp 10.10
bgp router-id 10.4.4.4
bgp asnotation dot
bgp log-neighbor-changes
no bgp default route-target filter
no bgp default ipv4-unicast
timers bgp 10 30
neighbor AS20 peer-group
neighbor AS20 remote-as 20
neighbor 10.3.3.3 remote-as 10.10
neighbor 10.3.3.3 update-source Loopback0
neighbor 10.12.1.6 peer-group AS20
!
address-family ipv4
no auto-summary
exit-address-family
!

```

```

address-family l2vpn vpls
  neighbor AS20 send-community extended
  neighbor AS20 next-hop-self
  neighbor 10.3.3.3 activate
  neighbor 10.3.3.3 send-community extended
  neighbor 10.3.3.3 next-hop-self
  neighbor 12.12.1.6 activate
exit-address-family
!
ip route 10.6.6.6 255.255.255.255 10.12.1.6
ip route 10.9.9.9 255.255.255.255 10.12.3.9
!
mpls ldp router-id Loopback0
!

```

RR_A Router

```

interface Loopback0
  ip address 10.3.3.3 255.255.255.255
!
interface Ethernet2/0
  ip address 10.100.100.3 255.255.255.0
  duplex half
!
router ospf 10
  network 10.3.3.3 0.0.0.0 area 0
  network 10.100.100.3 0.0.0.0 area 0
!
router bgp 10.10
  bgp asnotation dot
  bgp log-neighbor-changes
  no bgp default ipv4-unicast
  neighbor rr-client peer-group
  neighbor rr-client remote-as 10.10
  neighbor rr-client update-source Loopback0
  neighbor 10.1.1.1 peer-group rr-client
  neighbor 10.4.4.4 peer-group rr-client
!
  address-family ipv4
    no auto-summary
  exit-address-family
!
  address-family l2vpn vpls
    neighbor rr-client send-community extended
    neighbor rr-client route-reflector-client
    neighbor 10.1.1.1 activate
    neighbor 10.4.4.4 activate
  exit-address-family
!

```

PE_B1 Router

```

mpls ldp discovery targeted-hello accept
mpls label protocol ldp
!
l2 router-id 10.5.5.5
l2 pseudowire routing
  terminating-pe tie-breaker
l2 vfi vfiA autodiscovery
  vpn id 111
  vpls-id 111:111

```

```

rd 111:111
route-target 111:111
no auto-route-target
!
interface Loopback0
ip address 10.5.5.5 255.255.255.255
!
interface GigabitEthernet2/0/7
description AS20-Backbone-LAN
ip address 10.100.100.5 255.255.255.0
mpls ip
!
router ospf 20
network 10.5.5.5 0.0.0.0 area 0
network 10.100.100.5 0.0.0.0 area 0
!
router bgp 20
bgp router-id 10.5.5.5
bgp asnotation dot
bgp log-neighbor-changes
no bgp default ipv4-unicast
neighbor 10.8.8.8 remote-as 20
neighbor 10.8.8.8 update-source Loopback0
!
address-family ipv4
no auto-summary
exit-address-family
!
address-family l2vpn vpls
neighbor 10.8.8.8 activate
neighbor 10.8.8.8 send-community extended
exit-address-family
!
mpls ldp router-id Loopback0
!

```

ASBR_B1 Router

```

mpls ldp discovery targeted-hello accept
mpls label protocol ldp
!
l2 router-id 10.6.6.6
l2 pseudowire routing
terminating-pe tie-breaker
!
interface Loopback0
ip address 10.6.6.6 255.255.255.255
!
interface Ethernet1/3
description B2B-AS-10.10-ASBR-A
ip address 10.12.1.6 255.255.255.0
duplex half
mpls ip
!
interface Ethernet2/1
description AS-20-backbone-Lan
ip address 10.100.100.6 255.255.255.0
duplex half
mpls ip
!
router ospf 20
passive-interface Ethernet1/3
network 10.12.1.6 0.0.0.0 area 0

```



```

network 10.6.6.6 0.0.0.0 area 0
network 10.100.100.6 0.0.0.0 area 0
!
router bgp 20
  bgp router-id 10.6.6.6
  bgp asnotation dot
  bgp log-neighbor-changes
  no bgp default ipv4-unicast
  timers bgp 10 30
  neighbor 10.12.1.4 remote-as 10.10
  neighbor 10.12.1.4 ebgp-multihop 255
  neighbor 10.8.8.8 remote-as 20
  neighbor 10.8.8.8 update-source Loopback0
  !
  address-family ipv4
    no auto-summary
  exit-address-family
  !
  address-family l2vpn vpls
    no bgp default route-target filter
    neighbor 10.12.1.4 activate
    neighbor 10.12.1.4 send-community extended
    neighbor 10.12.1.4 next-hop-self
    neighbor 10.8.8.8 activate
    neighbor 10.8.8.8 send-community extended
    neighbor 10.8.8.8 next-hop-self
  exit-address-family
  !

```

RR_B Router

```

interface Loopback0
  ip address 10.8.8.8 255.255.255.255
  !
interface Ethernet2/1
  ip address 10.100.100.8 255.255.255.0
  duplex half
  !
router ospf 20
  network 10.8.8.8 0.0.0.0 area 0
  network 10.100.100.8 0.0.0.0 area 0
  !
router bgp 20
  bgp log-neighbor-changes
  no bgp default ipv4-unicast
  neighbor rrc peer-group
  neighbor rrc remote-as 20
  neighbor rrc update-source Loopback0
  neighbor 10.5.5.5 peer-group rrc
  neighbor 10.6.6.6 peer-group rrc
  neighbor 10.9.9.9 peer-group rrc
  neighbor 10.9.9.9 shutdown
  !
  address-family ipv4
    no auto-summary
  exit-address-family
  !
  address-family l2vpn vpls
    neighbor rrc send-community extended
    neighbor rrc route-reflector-client
    neighbor 10.5.5.5 activate
    neighbor 10.6.6.6 activate
    neighbor 10.9.9.9 activate

```

```

exit-address-family
!

```

Example Sample L2VPN VPLS Inter-AS Option B Configuration using the commands associated with the L2VPN Protocol-Based CLIs feature

The example below is a sample L2VPN VPLS Inter-AS Option B configuration based on the topology shown in the following figure.

Figure 3: L2VPN VPLS Inter-AS Option B Topology Used for Configuration Example

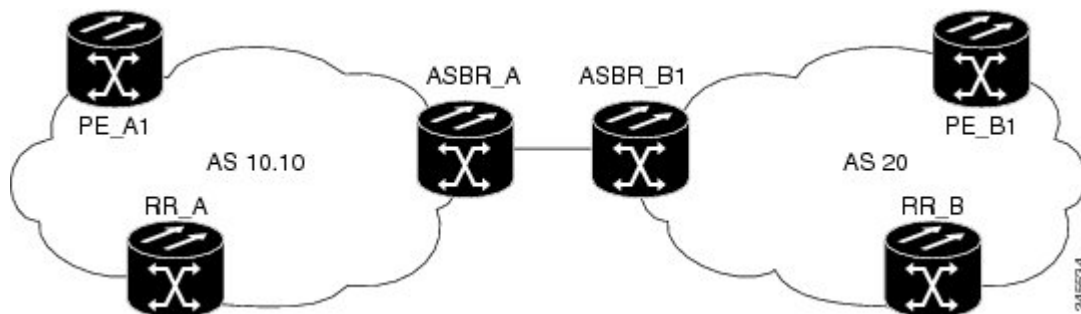

The topology shown in the figure above consists of two provider edge (PE) routers connected across an autonomous system boundary using two ASBRs. Routes are shared within each autonomous system using BGP route reflectors (RRs). (The RRs are included only for the purpose of showing a complete configuration. RRs are not a requirement for the L2VPN Inter-AS Option B configuration.)

The specific configurations for each of the elements in this topology are shown below. The commands highlighted in bold indicate the additions needed to the standard VPLS Autodiscovery: BGP Based configuration.

PE_A1 Router

```

mpls ldp discovery targeted-hello accept
mpls label protocol ldp
!
l2vpn
  router-id 10.1.1.1
  pseudowire routing
    terminating-pe tie-breaker
!
l2vpn vfi context vfiA
  vpn id 111
  autodiscovery bgp signaling ldp
  vpls-id 111:111
  rd 111:111
  route-target 111:111
  no auto-route-target
!
!
interface Loopback0
  ip address 10.1.1.1 255.255.255.255
!
!
interface GigabitEthernet2/0/9
  description AS-10.10-Backbone-LAN

```

```

ip address 10.100.100.1 255.255.255.0
mpls ip
!
router ospf 10
 network 10.1.1.1 0.0.0.0 area 0
 network 10.100.100.1 0.0.0.0 area 0
!
router bgp 10.10
 bgp asnotation dot
 bgp log-neighbor-changes
 no bgp default ipv4-unicast
 neighbor 10.3.3.3 remote-as 10.10
 neighbor 10.3.3.3 description RR-AS-10.10
 neighbor 10.3.3.3 update-source Loopback0
!
 address-family ipv4
  no auto-summary
 exit-address-family
!
 address-family l2vpn vpls
  neighbor 10.3.3.3 activate
  neighbor 10.3.3.3 send-community extended
 exit-address-family
!
mpls ldp router-id Loopback0
!

```

ASBR_A Router

```

mpls ldp discovery targeted-hello accept
mpls label protocol ldp
!
!
interface Loopback0
 ip address 10.4.4.4 255.255.255.255
!
interface GigabitEthernet1/10
 description AS-10.10-backbone-Lan
 ip address 10.100.100.4 255.255.255.0
 mpls ip
!
interface GigabitEthernet2/0/1
 description B2B-AS-20-ASBR-B1
 ip address 10.12.1.4 255.255.255.0
 mpls ip
!
router ospf 10
 passive-interface GigabitEthernet1/12
 passive-interface GigabitEthernet2/0/1
 passive-interface GigabitEthernet2/0/2
 network 10.4.4.4 0.0.0.0 area 0
 network 10.100.100.4 0.0.0.0 area 0
 network 10.12.0.0 0.0.255.255 area 0
!
router bgp 10.10
 bgp router-id 10.4.4.4
 bgp asnotation dot
 bgp log-neighbor-changes
 no bgp default route-target filter
 no bgp default ipv4-unicast
 timers bgp 10 30
 neighbor AS20 peer-group
 neighbor AS20 remote-as 20

```

```

neighbor 10.3.3.3 remote-as 10.10
neighbor 10.3.3.3 update-source Loopback0
neighbor 10.12.1.6 peer-group AS20
!
address-family ipv4
  no auto-summary
exit-address-family
!
address-family l2vpn vpls
  neighbor AS20 send-community extended
  neighbor AS20 next-hop-self
  neighbor 10.3.3.3 activate
  neighbor 10.3.3.3 send-community extended
  neighbor 10.3.3.3 next-hop-self
  neighbor 12.12.1.6 activate
exit-address-family
!
ip route 10.6.6.6 255.255.255.255 10.12.1.6
ip route 10.9.9.9 255.255.255.255 10.12.3.9
!
mpls ldp router-id Loopback0
!

```

RR_A Router

```

interface Loopback0
  ip address 10.3.3.3 255.255.255.255
!
interface Ethernet2/0
  ip address 10.100.100.3 255.255.255.0
  duplex half
!
router ospf 10
  network 10.3.3.3 0.0.0.0 area 0
  network 10.100.100.3 0.0.0.0 area 0
!
router bgp 10.10
  bgp asnotation dot
  bgp log-neighbor-changes
  no bgp default ipv4-unicast
  neighbor rr-client peer-group
  neighbor rr-client remote-as 10.10
  neighbor rr-client update-source Loopback0
  neighbor 10.1.1.1 peer-group rr-client
  neighbor 10.4.4.4 peer-group rr-client
!
address-family ipv4
  no auto-summary
exit-address-family
!
address-family l2vpn vpls
  neighbor rr-client send-community extended
  neighbor rr-client route-reflector-client
  neighbor 10.1.1.1 activate
  neighbor 10.4.4.4 activate
exit-address-family
!

```

PE_B1 Router

```

mpls ldp discovery targeted-hello accept

```

```

mpls label protocol ldp
!
l2vpn
  router-id 10.5.5.5
  pseudowire routing
  terminating-pe tie-breaker
l2vpn vfi context vfiA
  vpn id 111
  autodiscovery bgp signaling ldp
  vpls-id 111:111
  rd 111:111
  route-target 111:111
  no auto-route-target
!
interface Loopback0
  ip address 10.5.5.5 255.255.255.255
!
interface GigabitEthernet2/0/7
  description AS20-Backbone-LAN
  ip address 10.100.100.5 255.255.255.0
  mpls ip
!
router ospf 20
  network 10.5.5.5 0.0.0.0 area 0
  network 10.100.100.5 0.0.0.0 area 0
!
router bgp 20
  bgp router-id 10.5.5.5
  bgp asnotation dot
  bgp log-neighbor-changes
  no bgp default ipv4-unicast
  neighbor 10.8.8.8 remote-as 20
  neighbor 10.8.8.8 update-source Loopback0
!
  address-family ipv4
    no auto-summary
  exit-address-family
!
  address-family l2vpn vpls
    neighbor 10.8.8.8 activate
    neighbor 10.8.8.8 send-community extended
  exit-address-family
!
mpls ldp router-id Loopback0
!

```

ASBR_B1 Router

```

mpls ldp discovery targeted-hello accept
mpls label protocol ldp
!
l2vpn
  router-id 10.6.6.6
  pseudowire routing
  terminating-pe tie-breaker
!
interface Loopback0
  ip address 10.6.6.6 255.255.255.255
!
interface Ethernet1/3
  description B2B-AS-10.10-ASBR-A
  ip address 10.12.1.6 255.255.255.0
  duplex half

```

```

mpls ip
!
interface Ethernet2/1
description AS-20-backbone-Lan
ip address 10.100.100.6 255.255.255.0
duplex half
mpls ip
!
router ospf 20
passive-interface Ethernet1/3
network 10.12.1.6 0.0.0.0 area 0
network 10.6.6.6 0.0.0.0 area 0
network 10.100.100.6 0.0.0.0 area 0
!
router bgp 20
bgp router-id 10.6.6.6
bgp asnotation dot
bgp log-neighbor-changes
no bgp default ipv4-unicast
timers bgp 10 30
neighbor 10.12.1.4 remote-as 10.10
neighbor 10.12.1.4 ebgp-multihop 255
neighbor 10.8.8.8 remote-as 20
neighbor 10.8.8.8 update-source Loopback0
!
address-family ipv4
no auto-summary
exit-address-family
!
address-family l2vpn vpls
no bgp default route-target filter
neighbor 10.12.1.4 activate
neighbor 10.12.1.4 send-community extended
neighbor 10.12.1.4 next-hop-self
neighbor 10.8.8.8 activate
neighbor 10.8.8.8 send-community extended
neighbor 10.8.8.8 next-hop-self
exit-address-family
!

```

RR_B Router

```

interface Loopback0
ip address 10.8.8.8 255.255.255.255
!
interface Ethernet2/1
ip address 10.100.100.8 255.255.255.0
duplex half
!
router ospf 20
network 10.8.8.8 0.0.0.0 area 0
network 10.100.100.8 0.0.0.0 area 0
!
router bgp 20
bgp log-neighbor-changes
no bgp default ipv4-unicast
neighbor rrc peer-group
neighbor rrc remote-as 20
neighbor rrc update-source Loopback0
neighbor 10.5.5.5 peer-group rrc
neighbor 10.6.6.6 peer-group rrc
neighbor 10.9.9.9 peer-group rrc
neighbor 10.9.9.9 shutdown

```

```

!
address-family ipv4
  no auto-summary
exit-address-family
!
address-family l2vpn vpls
  neighbor rrc send-community extended
  neighbor rrc route-reflector-client
  neighbor 10.5.5.5 activate
  neighbor 10.6.6.6 activate
  neighbor 10.9.9.9 activate
exit-address-family
!

```

Additional References for L2VPN VPLS Inter-AS Option B

Related Documents

Related Topic	Document Title
Cisco IOS commands	Cisco IOS Master Command List, All Releases
MPLS commands	Cisco IOS Multiprotocol Label Switching Command Reference
IP Routing (BGP) commands	Cisco IOS IP Routing: BGP Command Reference
Concepts and tasks related to configuring the VPLS Autodiscovery: BGP Based feature.	<i>VPLS Autodiscovery BGP Based</i>
BGP support for the L2VPN address family	<i>BGP Support for the L2VPN Address Family</i>
VPLS	“VPLS Overview” section in the <i>Configuring Multiprotocol Label Switching on the Optical Services Modules</i> document
L2VPN multisegment pseudowires, MPLS OAM support for L2VPN multisegment pseudowires, MPLS OAM support for L2VPN inter-AS option B	<i>L2VPN Multisegment Pseudowires</i>

Standards

Standard	Title
No new or modified standards are supported, and support for existing standards has not been modified.	—

MIBs

MIB	MIBs Link
No new or modified MIBs are supported, and support for existing standards has not been modified.	To locate and download MIBs for selected platforms, Cisco software releases, and feature sets, use Cisco MIB Locator found at the following URL: http://www.cisco.com/go/mibs

RFCs

RFC	Title
RFC 4360	<i>BGP Extended Communities Attribute</i>
RFC 4364	<i>BGP/MPLS IP Virtual Private Networks (VPNs)</i>

Technical Assistance

Description	Link
The Cisco Support and Documentation website provides online resources to download documentation, software, and tools. Use these resources to install and configure the software and to troubleshoot and resolve technical issues with Cisco products and technologies. Access to most tools on the Cisco Support and Documentation website requires a Cisco.com user ID and password.	http://www.cisco.com/cisco/web/support/index.html

Feature Information for L2VPN VPLS Inter-AS Option B

The following table provides release information about the feature or features described in this module. This table lists only the software release that introduced support for a given feature in a given software release train. Unless noted otherwise, subsequent releases of that software release train also support that feature.

Use Cisco Feature Navigator to find information about platform support and Cisco software image support. To access Cisco Feature Navigator, go to www.cisco.com/go/cfn. An account on Cisco.com is not required.

Table 1: Feature Information for L2VPN VPLS Inter-AS Option B

Feature Name	Releases	Feature Information
L2VPN VPLS Inter-AS Option B	15.1(1)S Cisco IOS XE Release 3.8S	<p>The L2VPN VPLS Inter-AS Option B feature expands the existing features of VPLS autodiscovery to operate across multiple BGP autonomous systems. Using BGP-based autodiscovery as the underlying framework, the L2VPN VPLS Inter-AS Option B features creates a dynamic multisegmented pseudowire configuration between neighboring ASBRs.</p> <p>The following commands were introduced or modified: bgp default route-target filter, debug xconnect, l2 pseudowire routing, show ip bgp neighbors, show mpls forwarding-table, show mpls l2transport vc, show xconnect, switching-point vcid, and terminating-pe tie-breaker.</p>

Glossary

AGI—Attachment Group Identifier. An identifier common to a group of pseudowires that may be connected.

AII—Attachment individual identifier.

ASBR—Autonomous System Boundary Router.

PE—provider edge router.

NLRI—Network Layer Reachability Information.

SAII—Source Attachment Individual Identifier.

SPE—switching PE.

TAII—Target Attachment Individual Identifier.

TPE—terminating PE.

VFI—virtual forwarding instance. This identifies a group of pseudowires that are associated with a VSI.

VSI—virtual switching instance. This identifies the bridge domain within a single PE. In a single VPLS network, each participating PE has a VSI.

