



DNA SA Border Node Support

Digital Network Architecture (DNA) Security Access (SA) is an Enterprise architecture that brings together multiple building blocks needed for a programmable, secure, and highly automated fabric. Secure Fabric forms the foundation of this architecture and is targeted to address next generation campus trends. From Cisco IOS XE Everest 16.4.1 release, ASR 1000/ISR 4000 platforms can be supported as the border node of DNA SA fabric, handing off the enterprise campus fabric to iWAN, providing IP connectivity across campus and branches. The fabric is separated for campus and branches, and the border node will hand off the LISP/VxLAN-GPO fabric to WAN. In the 16.4.1 release, the handoff is to the DMVPN/MPLS WAN with manual configuration.

- [Finding Feature Information, on page 1](#)
- [Restrictions for DNA SA Border Node Support, on page 1](#)
- [Information About DNA SA Border Node Support, on page 2](#)
- [Configuration Example: Border Node as LISP PxTR, on page 5](#)
- [Configuration Example: Border Node as LISP xTR, on page 9](#)
- [Feature Information for DNA SA Border Node Support, on page 11](#)

Finding Feature Information

Your software release may not support all the features documented in this module. For the latest caveats and feature information, see [Bug Search Tool](#) and the release notes for your platform and software release. To find information about the features documented in this module, and to see a list of the releases in which each feature is supported, see the feature information table.

Use Cisco Feature Navigator to find information about platform support and Cisco software image support. To access Cisco Feature Navigator, go to www.cisco.com/go/cfn. An account on Cisco.com is not required.

Restrictions for DNA SA Border Node Support

- IPv6 RLOC and IPv6 EID is not supported for DNA SA.
- IPv4 SGT can control (enable or disable) IPv4/IPv6 EID SGT. IPv6 SGT is not supported.
- Multicast configuration cannot change encapsulation type.

Information About DNA SA Border Node Support

Enabling VxLAN Encapsulation for LISP Control Plane

To enable VXLAN encapsulation for LISP, use the encapsulation vxlan command in the router lisp configuration mode. This command must be configured on all LISP edge devices in the enterprise fabric deployment: Ingress Tunnel Router (ITR), Egress Tunnel Router (ETR), Proxy Ingress Tunnel Router (PITR), Proxy Egress Tunnel Router (PETR). Failure to configure this command on any of the LISP edge devices will result in loss of control and data traffic.

Use the **show platform software lisp udp-src-port ipv4 src_ip dest_ip protocol** command to see the UDP source port according to the data packets. You can also use **ipv6** in the command.



Note VXLAN must not be configuration on the device when VXLAN encapsulation is enabled for LISP. Conversely, VXLAN encapsulation for LISP must not be enabled when configuring other VXLAN protocols.

Two deployment modes are supported, one is to configure border node as PxTR and the other is to configure border node as XTR.

Configuring Border Node as LISP PxTR

Border node can be configured as PxTR for the fabric.

Figure 1: Border Node as LISP PxTR

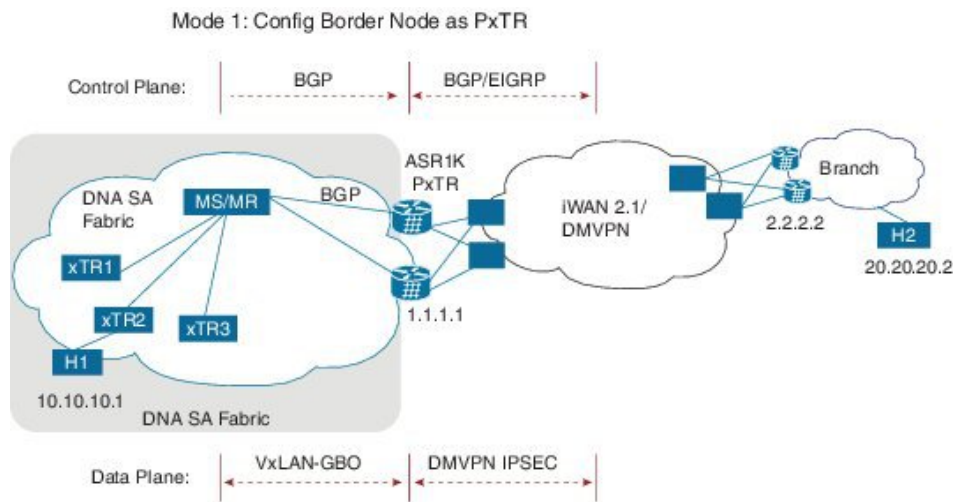

380372

Control Plane Connectivity

Campus-to-Branches direction:

- xTR will register its direct attached host to MS/MR through LISP map-register.
- There will be per-VRF BGP sessions between MS/MR and PxTR, MS/MR will advertise LISP routes to PxTR
- PxTR will re-originate those routes to WAN through EIGRP or BGP.

Branches-to-Campus direction:

- Branch routes will advertise its routes to border nodes of campus through EIGRP or BGP.
- Border nodes (PxTR) will not advertise routes to LISP MS/MR.
- On XTR, configure “ipv4 use-petr <rloc of PxTR> ”

Packet Flow with Control Plan Interworking

H1 to H2: SIP:10.10.10.1, DIP: 20.20.20.2

- Assuming xTR2 is the default gateway for H1 (it might not be the access switch, but the distribution switch instead). H1 sends the IP packet to xTR2 after it resolves the ARP entry for gateway MAC.
- On xTR2, the IPv4 use-petr 2.2.2.2 is configured.
- On xTR2, a MAP request is initiated to MAP request, to resolve 20.20.20.2
- A negative MAP reply is sent from MS/MR to xTR2.
- xTR2 encapsulation with LISP head and sends to LISP PxTR 1.1.1.1
- Branch router 2.2.2.2 advertises 20.20.20/24 routes to border node 1.1.1.1 using WAN protocol BGP/EIGRP.
- PxTR send the packet to remote branch router 2.2.2.2 through iWAN/DMVPN.

H2 to H1: SIP: 20.20.20.2, DIP: 10.10.10.1

- xTR2 register 10.10.10.1 to MS/MS through LISP MAP-register.
- MS/MR advertise this route to PxTR 1.1.1.1
- PxTR re-originate route to branch route 2.2.2.2
- H2 sends the packets to branch router 2.2.2.2
- Branch router 2.2.2.2 forwards the packets to PxTR 1.1.1.1
- PxTR sends MAP-request to resolve 10.10.10.1, and the MAP-reply is from xTR2.
- PxTR sends LISP packets to xTR2 and then to H1.

Configuring Border Node as LISP xTR

Border node can be configured as xTR for the fabric.

Figure 2: Border Node as LISP xTR

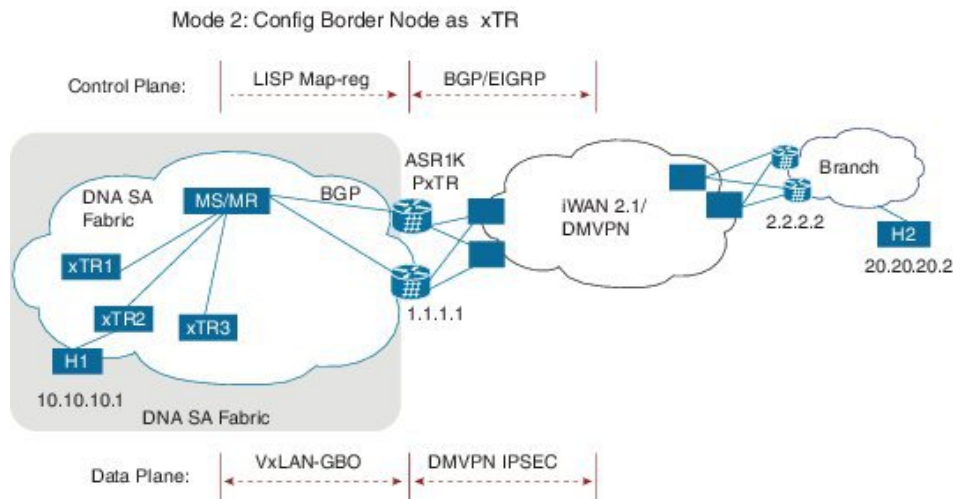

38/573

Control Plane Connectivity

Campus-to-Branche direction--For each subnet of fabric, you must manually configure a static route to null0 on ASR1K xTR. Example: `ip route vrf vrf1 10.10.1 255.255.255.0 Null0 tag 110 ASR1K xTR (1.1.1.1)` will advertise this static route to remote branches (2.2.2.2) through BGP or EIGRP.

Branche-to-Campus direction--Remote Branche (2.2.2.2) will advertise routes 20.20.20.2 to ASR1K xTR (1.1.1.1) through BGP or EIGRP. On ASR1K xTR, configure “`ipv4 route-import database bgp 100 ...`” under LISP EID table to import BGP/EIGRP as LISP EID table. ASR1K xTR 2.2.2.2 will initiate MAP-register to register the EID learnt from BGP.

Packet Flow with Control Plan Interworking

H1 to H2: SIP:10.10.10.1, DIP: 20.20.20.2

- Branche route 2.2.2.2 advertises routes 20.20.20.0/24 to LISP xTR 1.1.1.1 through BGP/EIGRP.
- LISP xTR 1.1.1.1 will import 20.20.20.0/24 into local EID table.
- LISP xTR 1.1.1.1 sends MAP-register to MS/MR to register 20.20.20.0/24 as its local EID
- H1 sends IP packets to xTR2 after it resolves the MAC address of xTR2.
- xTR2 sends map-request to resolve the device for 20.20.20.2 and the RLOC is 1.1.1.1
- xTR2 sends VxLAN encapsulated packets to 1.1.1.1
- RLOC 1.1.1.1 terminates VxLAN and forwards the packets to 2.2.2.2.

H2 to H1: SIP: 20.20.20.2, DIP: 10.10.10.1

- Static route of 10.10.10.1/24 is configured on xTR 1.1.1.1 and it points to null0
- xTR advertises this route to branche 2.2.2.2
- H2 sends packets to branche router 2.2.2.2
- Branche router forwards the packets to LISP xTR 1.1.1.1
- Branche router 2.2.2.2 forwards the packets to PxTR 1.1.1.1
- On LISP xTR 1.1.1.1, 10.10.10.1/24 is pointed to null0, which will trigger LISP routing; it will send MAP-request to resolve the RLOC for 10.10.10.1.
- LISP xTR 1.1.1.1 sends VxLAN encapsulated packets to xTR2.

Security Group Tag (SGT) Propagation

Besides the control plane and data plane connectivity, the SGT tag must be carried over from the campus fabric to WAN and vice-versa, so that SGT tag based policy will be enforced end-to-end across campus and branches. This function has dependence on WAN; if the WAN cannot carry the SGT tag, the tag will be lost.

Configuration Example: Border Node as LISP PxTR

Border node configuration:

```
vrf definition vrf1
 rd 1:1
 !
 address-family ipv4
  route-target export 1:1
  route-target import 1:1
 exit-address-family
 !
vrf definition vrf2
 rd 1:2
 !
 address-family ipv4
  route-target export 1:2
  route-target import 1:2
 exit-address-family
 !
interface Loopback1
 vrf forwarding vrf1
 ip address 7.7.7.7 255.255.255.255
 !
interface Tunnel100
 description "iwan tunnel for vrf1"
 vrf forwarding vrf1
 ip address 100.0.0.1 255.255.255.0
 tunnel source GigabitEthernet2
 tunnel destination 16.0.0.2
 tunnel key 100
 !
interface Tunnel101
 description "iwan tunnel for vrf2"
 vrf forwarding vrf2
 ip address 101.0.0.1 255.255.255.0
 tunnel source GigabitEthernet2
 tunnel destination 16.0.0.2
 tunnel key 101
 !
interface Tunnel1000
 description "pxtr and msr tunnel vrf1"
 vrf forwarding vrf1
 ip address 200.0.0.2 255.255.255.0
 tunnel source GigabitEthernet1
 tunnel destination 13.0.0.1
 tunnel key 1000
 !
interface Tunnel1001
 description "pxtr and msr tunnel vrf2"
 vrf forwarding vrf2
 ip address 201.0.0.2 255.255.255.0
 tunnel source GigabitEthernet1
```

```

tunnel destination 13.0.0.1
tunnel key 1001
!
interface GigabitEthernet1
 ip address 15.0.0.2 255.255.255.0
 ip ospf 1 area 0
!
interface GigabitEthernet2
 ip address 16.0.0.1 255.255.255.0
!
router lisp
 encapsulation vxlan //Enable VXLAN GPO encapsulation for the LISP data plane//
 eid-table default instance-id 0
 map-cache 0.0.0.0/0 map-request
 exit
!
eid-table vrf vrf1 instance-id 1
 ipv4 route-import map-cache bgp 100 route-map set_lisp_vrf1
 exit
!
eid-table vrf vrf2 instance-id 2
 ipv4 route-import map-cache bgp 100 route-map set_lisp_vrf2
 exit
!
ipv4 sgt //enable SGT function for SGT tag propagation//
 exit
!
ipv4 map-request-source 14.0.0.2
 ipv4 proxy-etr
 ipv4 proxy-itr 15.0.0.2
 ipv4 itr map-resolver 14.0.0.1
 exit
!
router ospf 1
!
router bgp 100
 bgp log-neighbor-changes
!
 address-family ipv4 vrf vrf1
  neighbor 100.0.0.2 remote-as 100
  neighbor 100.0.0.2 activate
  neighbor 200.0.0.1 remote-as 200
  neighbor 200.0.0.1 ebgp-multihop 255
  neighbor 200.0.0.1 update-source Tunnel1000
  neighbor 200.0.0.1 activate
  neighbor 200.0.0.1 send-community both
 exit-address-family
!
 address-family ipv4 vrf vrf2
  neighbor 101.0.0.2 remote-as 100
  neighbor 101.0.0.2 activate
  neighbor 201.0.0.1 remote-as 200
  neighbor 201.0.0.1 ebgp-multihop 255
  neighbor 201.0.0.1 update-source Tunnel1001
  neighbor 201.0.0.1 activate
  neighbor 201.0.0.1 send-community both
 exit-address-family
!
 ip bgp-community new-format
 ip community-list 10 permit 1000:1
 ip community-list 11 permit 1000:2
!
 route-map set_lisp_vrf1 permit 10
 match community 10

```

```
!  
route-map set_lisp_vrf2 permit 10  
match community 11  
!  
!  
MSMR configuration:  
vrf definition vrf1  
  rd 1:1  
  !  
  address-family ipv4  
  exit-address-family  
  !  
vrf definition vrf1000  
  rd 1000:1  
  !  
  address-family ipv4  
  exit-address-family  
  !  
vrf definition vrf2  
  rd 1:2  
  !  
  address-family ipv4  
  exit-address-family  
  !  
interface Loopback0  
  ip address 14.0.0.1 255.255.255.255  
  ip ospf 1 area 0  
  !  
interface Tunnel1000  
  description "pxtr and msmr tunnel vrf1"  
  vrf forwarding vrf1  
  ip address 200.0.0.1 255.255.255.0  
  tunnel source GigabitEthernet3.6  
  tunnel destination 15.0.0.2  
  tunnel key 1000  
  !  
interface Tunnel1001  
  description "pxtr and msmr tunnel vrf2"  
  vrf forwarding vrf2  
  ip address 201.0.0.1 255.255.255.0  
  tunnel source GigabitEthernet3.6  
  tunnel destination 15.0.0.2  
  tunnel key 1001  
  !  
interface GigabitEthernet2  
  no ip address  
  !  
interface GigabitEthernet2.4  
  encapsulation dot1Q 4  
  ip address 12.0.0.2 255.255.255.0  
  ip ospf 1 area 0  
  !  
interface GigabitEthernet2.5  
  encapsulation dot1Q 5  
  ip address 12.0.1.2 255.255.255.0  
  ip ospf 1 area 0  
  !  
interface GigabitEthernet3  
  no ip address  
  negotiation auto  
  cdp enable  
  !  
interface GigabitEthernet3.6  
  encapsulation dot1Q 6
```

```

ip address 13.0.0.1 255.255.255.0
ip ospf 1 area 0
!
interface GigabitEthernet3.7
encapsulation dot1Q 7
ip address 13.0.1.1 255.255.255.0
ip ospf 1 area 0
!
router lisp
eid-table default instance-id 0
exit
!
eid-table vrf vrf1 instance-id 1
ipv4 route-export site-registrations
exit
!
eid-table vrf vrf2 instance-id 2
ipv4 route-export site-registrations
exit
!
rtr-set rtr
12.0.0.1 authentication-key cisco
12.0.1.1 authentication-key cisco
exit
!
map-server advertise-rtr-set rtr
site xtr1
authentication-key cisco
advertise-rtr-set rtr
eid-prefix 1.1.1.1/32 route-tag 110
eid-prefix instance-id 1 5.5.5.5/32 route-tag 100
exit
!
site xtr2
authentication-key cisco
eid-prefix 2.2.2.2/32 route-tag 110
eid-prefix instance-id 1 6.6.6.6/32 route-tag 100
eid-prefix instance-id 1 11.11.11.11/32 route-tag 120
eid-prefix instance-id 2 6.6.6.6/32 route-tag 110
exit
!
ipv4 map-server
ipv4 map-resolver
exit
!
router ospf 1
!
router bgp 200
bgp log-neighbor-changes
!
address-family ipv4 vrf vrf1
redistribute lisp metric 11 route-map set_lisp_vrf1
neighbor 200.0.0.2 remote-as 100
neighbor 200.0.0.2 ebgp-multihop 255
neighbor 200.0.0.2 update-source Tunnel1000
neighbor 200.0.0.2 activate
neighbor 200.0.0.2 send-community both
exit-address-family
!
address-family ipv4 vrf vrf2
redistribute lisp metric 11 route-map set_lisp_vrf2
neighbor 201.0.0.2 remote-as 100
neighbor 201.0.0.2 ebgp-multihop 255
neighbor 201.0.0.2 update-source Tunnel1001

```



```

neighbor 201.0.0.2 activate
neighbor 201.0.0.2 send-community both
exit-address-family
!
!
ip bgp-community new-format
!
route-map set_lisp_vrf1 permit 10
match tag 100
set community 1000:1
!
route-map set_lisp_vrf2 permit 10
match tag 110
set community 1000:2
!

```

Configuration Example: Border Node as LISP xTR

Border node configuration:

```

vrf definition vrf1
rd 1:1
!
address-family ipv4
route-target export 1:1
route-target import 1:1
exit-address-family
!
vrf definition vrf2
rd 1:2
!
address-family ipv4
exit-address-family
!
interface Loopback0
ip address 2.2.2.2 255.255.255.255
!
interface Loopback1
vrf forwarding vrf1
ip address 6.6.6.6 255.255.255.255
!
interface Tunnel200
description "iWAN tunnel to remote branch"
vrf forwarding vrf1
ip address 150.0.0.2 255.255.255.0
tunnel source GigabitEthernet2
tunnel destination 17.0.0.1
tunnel key 200
!
interface GigabitEthernet2
ip address 17.0.0.2 255.255.255.0
!
interface GigabitEthernet3
no ip address
!
interface GigabitEthernet3.6
encapsulation dot1Q 6
ip address 13.0.0.2 255.255.255.0
ip ospf 1 area 0
!
interface GigabitEthernet3.7

```

```

encapsulation dot1Q 7
ip address 13.0.1.2 255.255.255.0
ip ospf 1 area 0
!
interface GigabitEthernet4
ip address 15.0.0.1 255.255.255.0
ip ospf 1 area 0
!
router lisp
encapsulation vxlan
locator-set set1
13.0.0.2 priority 1 weight 1
13.0.1.2 priority 1 weight 1
exit
!
eid-table default instance-id 0
database-mapping 2.2.2.2/32 locator-set set1
exit
!
eid-table vrf vrf1 instance-id 1
database-mapping 6.6.6.6/32 locator-set set1
ipv4 route-import database bgp 100 route-map match_com locator-set set1
exit
!
eid-table vrf vrf2 instance-id 2
database-mapping 6.6.6.6/32 locator-set set1
exit
!
ipv4 sgt //enable SGT function for SGT tag propagation//
exit
!
ipv4 use-petr 15.0.0.2
ipv4 itr map-resolver 14.0.0.1
ipv4 itr
ipv4 etr map-server 14.0.0.1 key cisco
ipv4 etr
exit
!
router ospf 1
!
router bgp 100
bgp log-neighbor-changes
!
address-family ipv4 vrf vrf1
redistribute static route-map tag_110
neighbor 150.0.0.1 remote-as 100
neighbor 150.0.0.1 activate
neighbor 150.0.0.1 send-community both
exit-address-family

ip bgp-community new-format
ip community-list 10 permit 200:1
ip route vrf vrf1 5.5.5.5 255.255.255.255 Null0 tag 110
!
route-map tag_110 permit 10
match tag 110
!
route-map match_com permit 10
match community 10
!

```

Feature Information for DNA SA Border Node Support

The following table provides release information about the feature or features described in this module. This table lists only the software release that introduced support for a given feature in a given software release train. Unless noted otherwise, subsequent releases of that software release train also support that feature.

Use Cisco Feature Navigator to find information about platform support and Cisco software image support. To access Cisco Feature Navigator, go to www.cisco.com/go/cfn. An account on Cisco.com is not required.

Table 1: Feature Information for DNA SA Border Node Support

Feature Name	Releases	Feature Information
DNA SA Border Node Support	Cisco IOS XE Everest 16.4.1 Release	From Cisco IOS XE Everest 16.4.1 release, ASR 1000/ISR 4000 platforms can be supported as the border node of DNA SA fabric, handing off the enterprise campus fabric to iWAN, providing IP connectivity across campus and branches.

